



GREENTEK ENERGY SYSTEMS, LLC
www.GreentekEnergySystems.com

P/N:GT-FL-300W-N-DLgbdJ3-afKe

g=can be any letter for Surge protector provided or blank for none;

b= can be any letters for Photocontrol provided situation or blank for none;

d =can be any letters or blank,such as “Z”, “ZP”, “ZM” or blank,“Z” = DC Sensor Receptacle provided, “ZP” = DC Sensor Receptacle and DC photocontrol provided, “ZM” = DC Sensor Receptacle and DC motion sensor provided, blank = no DC Sensor Receptacle provided;

a=housing color;

fK=CCT, such as 40K=4000K,

45K=4500K,50K=5000K,57K=5700K,

e=Mount type ,such as “AM”, “DM”, “YM”, “UB”,“TM”,“IM”or “FM”.



DIMENSIONS

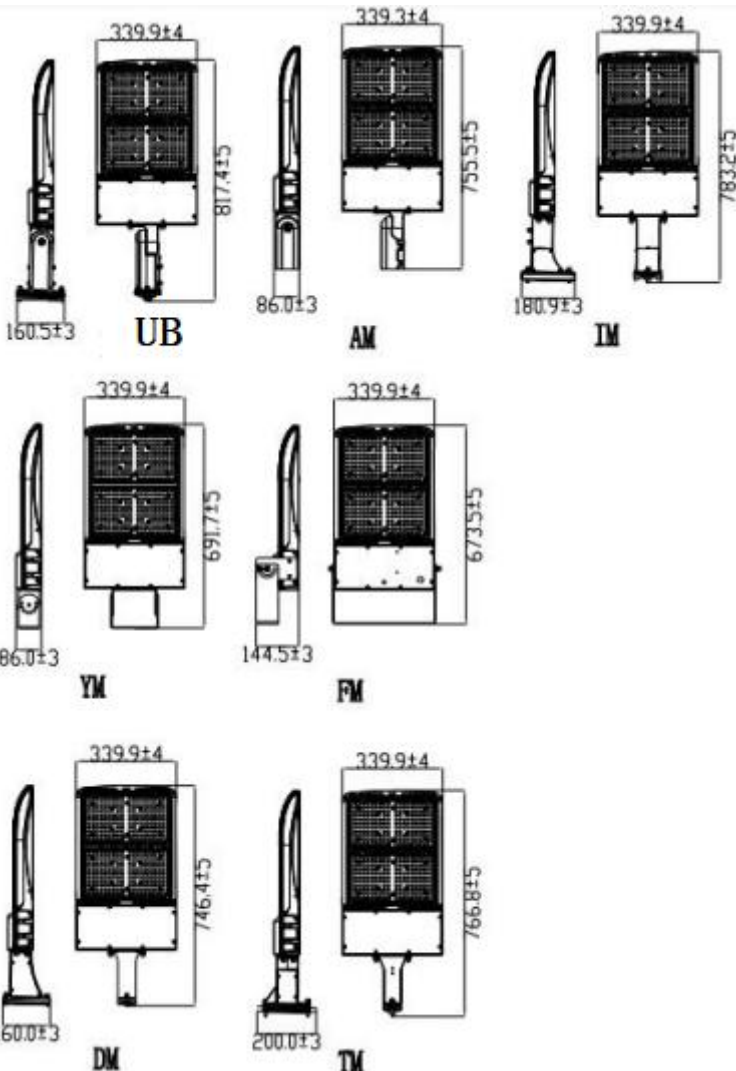

ADVANTAGE

- UL cUL DLC certificate.
- Bridgelux Chip, high CRI.
- IP65 driver, input voltage 120-277VAC.
- Output constant current lever can be adjusted through output cable with 0-10V.
- No UV or IR in the beam.
- Easy to install and operate.
- Energy saving, long lifespan.
- Light is soft and uniform, safe to eyes.
- Instant start, NO flickering, NO humming.
- Green and eco-friendly without mercury.

APPLICATION

- Outdoor basketball court, tennis court.
- Badminton court, the football field.
- The school playground, stadium.
- Community leisure entertainment plaza,

SPECIFICATIONS

OPTICAL	Input Power (Tolerance : ±10%)	300W			
	Color Temperature	4000K	4500K	5000K	5700K
	Lumen (Tolerance : -10%)	40500 LM	40500 LM	40500 LM	40500 LM
	Efficacy (Tolerance : -3%)	135 LM/W	135 LM/W	135 LM/W	135 LM/W
	CRI	>70			
	Color Consistency	<6 Steps (or <6 SDCM)			
	BUG	B4-U0-G5			
	Distribution Pattern	Type III			
	Beam Angle (50%) (Tolerance : ±15%)	160*115 Degree			
ELECTRICAL	Input Voltage and Frequency	120-277VAC, 50/60Hz;			
	PF (Tolerance : -3%)	≥ 0.9			
	THD (Tolerance : +5%)	≤20%			
	Flicker Percent	<50%			
	Driver Brand	Daermay			
	Driver Model	MP-150TG-130A*2			
	Driver Surge protection	L/N-PE: 6kV, L-N: 6kV			
	Dimming	0-10V dimming standard			
	Optional Accessory	Photocontrol, Surge-protective Device,Zhaga, Zhaga Motion Sensor,Zhaga photocontrol			
MATERIALS	LED Brand	Bridgelux			
	LED Type	SMD3030			
	LED QTY	340PCS			
	Housing	Die-cast aluminum			
	Housing Color	Brown, Black, or Customized			
	EPA	2.3ft²			
	Waterproof Rating	WET (IP65)			
OTHERS	Operating Temperature	Without Motion Sensor: -30°C TO 50°C; With Motion Sensor: -20°C TO 50°C			
	Storage Temperature	-40°C TO 85°C			
	Operating Humidity	20% - 90% RH			
	Storage Humidity	20% - 95% RH			
	Warranty	5 years warranty with 24/7 operating hours Luminaire lifetime at 25°C.			

PACKAGE

Bracket Type	Carton Size	Qty / Carton	Net Weight / Carton	Gross Weight / Carton
AM	820*390*165MM	1 PCS	9.1KG	10.8KG
DM	820*390*165MM	1 PCS	8KG	9.9KG
YM	820*390*165MM	1 PCS	9.1KG	10.8KG
FM	605*390*175MM	1 PCS	8.5KG	10.4KG
UB	820*390*165MM	1 PCS	9.1KG	10.8KG
TM	820*390*165MM	1 PCS	9.1KG	10.8KG
IM	820*390*165MM	1 PCS	9.1KG	10.8KG

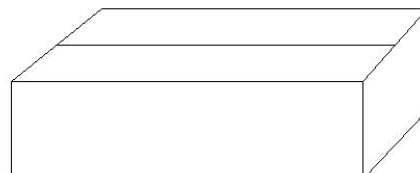
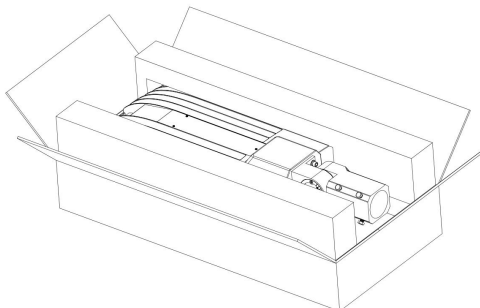

LIGHT DISTRIBUTION TESTING PARAMETERS

Luminaire Property

Luminaire Manufacturer:
 Luminaire Category:
 Lamp Catalog:
 Number of Lamps:
 Luminous Length (mm):
 Luminous Height (mm):
 Current: 2.516 A
 Power Factor: 0.993

Luminaire Description:
 Lamp Description:
 Lumens per Lamp:
 Luminous Width (mm):
 Voltage: 120.0 V
 Power: 300.98 W

Photometric Results

IES Classification: Type III
 Total Rated Lamp Lumens: 40425.2 lm
 Efficiency: 100%
 Upward Ratio: 0%
 C0r0 Intensity: 9933.77 cd
 Pos of Max. Intensity: H165 V72

Longitudinal Classification: Medium
 Measurement Flux: 40425.2 lm
 Downward Ratio: 100%
 Luminaire Efficacy Rating (LER): 134.36
 Max. Intensity: 12323.63 cd

Luminous Intensity Distribution Curve

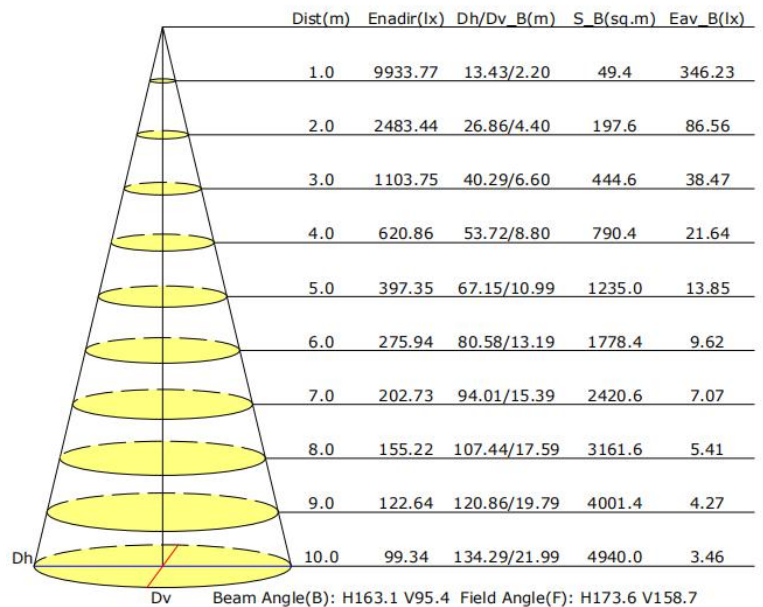
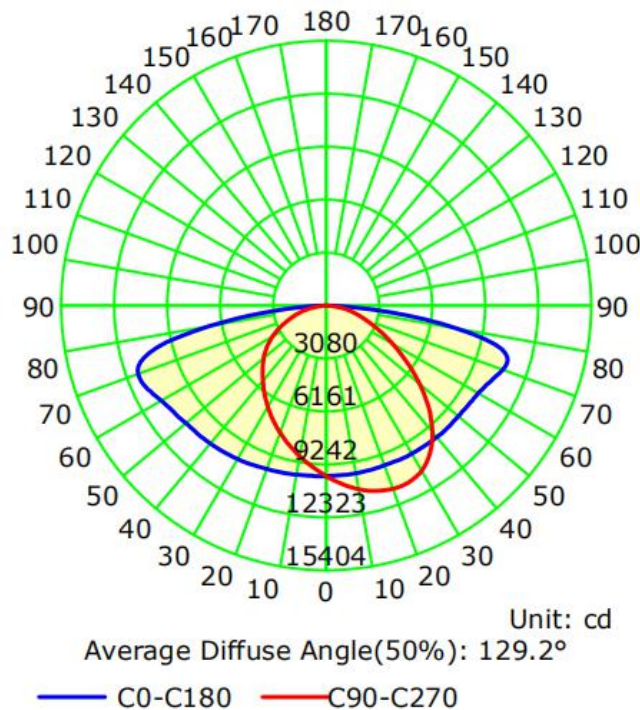

NOTICE FOR USER

- Please turn off power before install or change assembly parts.
- The input voltage and lamps should be matched, after connecting the power line, Please make sure the wiring section is insulated.
- No-professionals, must not install and disassemble the lamps.

TROUBLE SHOOTINGS

Troubles	Check points
Flickering of the light	Turn off the power and turn on again in 3 minutes. If same phenomena occur, then call agencies.
Out of working	Please check the connection.