

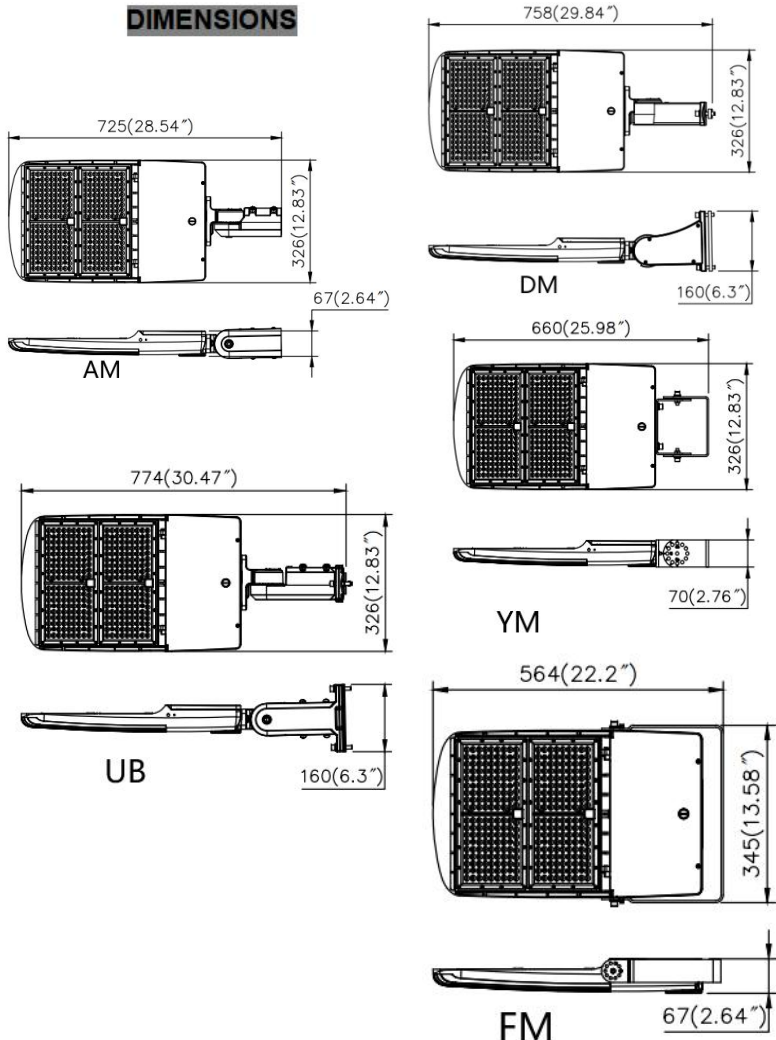

**GREENTEK ENERGY SYSTEMS, LLC**  
[www.GreentekEnergySystems.com](http://www.GreentekEnergySystems.com)



### DIMENSIONS



P/N: GT-AL3-300W-N-DLg**bd**fJ3-a**he**

GT= Company name;  
 AL3 = Product series;  
 300W = Rating Power;  
 N=LED driver type;  
 DL=120-277VAC driver;  
 g=can be any letter for Surge protector provided or blank for none;  
 b=can be any letters for Photocontrol provided situation or blank for none;  
 d=can be any letters or blank for sensor type provided or not;  
 f= can be "Z", "ZP", "ZM" or blank;  
 J =Lumileds LED;  
 3=Diffuser light angle type,3=TYPE III;  
 a =can be any two letters to represent lamp colors;  
 h= can be XXK to represent CCT,XXK can be 30K=3000K,35K=3500K,40K=4000K,45K=4500K, 50K=5000K, 57K=5700K;  
 e= mounting bracket types,can be AM,DM,YM,FM,UB.

### Advantage:

- UL certificate.
- Lumileds Chip, high CRI
- IP65 driver, Input voltage 120-277Vac
- Output constant current lever can be adjusted through output cable with 1-10V.
- No UV or IR in the beam
- Easy to install and operate
- Energy saving, Long lifespan
- Light is soft and uniform, Safe to eyes
- Instant start, NO flickering, NO humming
- Green and eco-friendly without mercury.

### Application:

- Outdoor basketball court, tennis court.
- Badminton court, the football field.
- The school playground, stadium.
- Community leisure entertainment plaza, road lamp etc.

## SPECIFICATIONS

<b>OPTICAL</b>	Input Power	300W
	Lumen	37500-42000LM
	Lumen Efficacy	125-140 LM/W
	Color Temperature	3000K,3500K,4000K,4500K,5000K,5700K
	CRI	>80
	Viewing Angle	158*95 Degree (Type III)
<b>ELECTRICAL</b>	Input Voltage	120-277VAC 50/60Hz
	PF	≥0.9
	THD	≤20%
	Driver Model	BECKY BQE160A-1000-160-PVF
	Sensor type	Occupancy Sensor/Exterior Photocell/Integral Sensor Receptacle
Optional Accessory	Photocontrol, Surge-protective Device, DC Motion Microwave sensor,DC Motion PIR sensor, photocell receptacle, shorting cap	
<b>MATERIALS</b>	LED Brand	Lumileds
	LED Type	2835
	LED QTY	374PCS
	Housing	Aluminum Alloy
	Housing Color	Black / Brown/white/Customized
	Waterproof Rating	WET (IP65)
<b>OTHERS</b>	Operating Temperature	Without Motion Sensor: -35℃TO 50℃; With Motion Sensor: -30℃TO 50℃
	Operating Humidity	10%-90% RH
	Storage Temperature	-40℃ TO 80℃
	Storage Humidity	10%-95% RH
	Warranty Time	5 Years

## PACKAGE

Stent Type	Lamps Net Weight	Size	Qty/ Carton	Weight/ Carton
AM	7.2Kg	745*370*145mm	1	8.6Kg
DM	7.8Kg	810*370*145mm	1	9.3Kg
YM	6.9Kg	685*370*145mm	1	8.4Kg
UB	7.7Kg	790*370*145mm	1	9.2Kg
FM	7.3Kg	670*370*145mm	1	8.8Kg

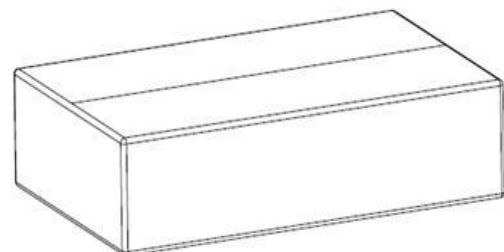
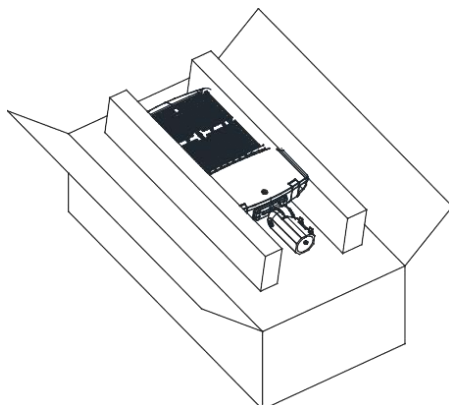

## **NOTICE FOR USER**

- Please turn off power before install or change assembly parts.
- The input voltage and lamps should be matched, after connecting the power line, Please make sure the wiring section is insulated.
- No-professionals, must not install and disassemble the lamps.

## **TROUBLE SHOOTINGS**

<b>Troubles</b>	<b>Check points</b>
Flickering of the light	Turn off the power and turn on again in 3 minutes. If same phenomena occur, then call agencies.
Out of working	Please check the connection.