



GREENTEK ENERGY SYSTEMS, LLC
www.GreentekEnergySystems.com



P/N:GT-AL2-100W-N-DLgb[M;Blank]fJ3-ahKe
g=can be any letter for Surge protector provided or blank for none;
b= can be any letters for Photocontrol provided situation or blank for none;
[M;Blank]= can be “M” for AC motion sensor type provided or blank for none;
f=can be any letters or blank,such as “Z”, “ZP”, “ZM” or blank,“Z” = DC Sensor Receptacle provided, “ZP” = DC Sensor Receptacle and DC photocontrol provided, “ZM” = DC Sensor Receptacle and DC motion sensor provided, blank = no DC Sensor Receptacle provided;
a=housing color can be any two letters;
hK=CCT, such as
30K=3000,5K=3500K,40K=4000K,45K=4500K,50K=5000K,57K=5700K,
e=Mount type ,such as “AM”, “DM”, “YM”, “UB”,“TM”,“IM”or “FM.”

DIMENSIONS

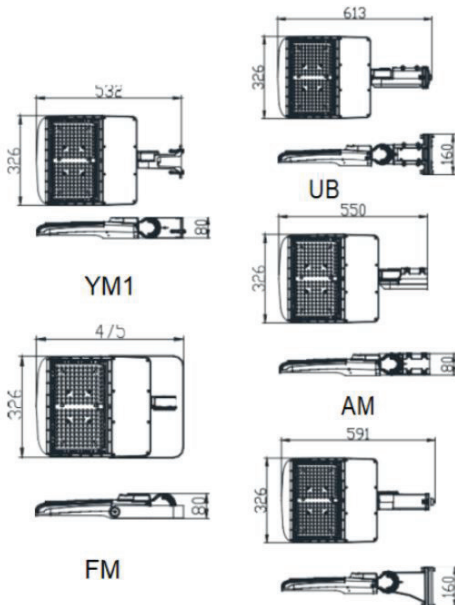

ADVANTAGE

- UL cUL DLC certificate.
- Bridgelux Chip, high CRI.
- IP65 driver, input voltage120-277VAC.
- Output constant current lever can be adjusted through output cable with 0-10V.
- No UV or IR in the beam.
- Easy to install and operate.
- Energy saving, long lifespan.
- Light is soft and uniform, safe to eyes.
- Instant start, NO flickering, NO humming.
- Green and eco-friendly without mercury.

APPLICATION

- Outdoor basketball court, tennis court.
- Badminton court, the football field.
- The school playground, stadium.
- Community leisure entertainment plaza, road lamp etc.

SPECIFICATIONS

OPTICAL	Input Power	100W
	Lumen	12500-13500LM
	Lumen Efficacy	125-135 LM/W
	Color Temperature	3000K,3500K,4000K,4500K,5000K, 5700K
	CRI	>70
	Viewing Angle	160*96 Degree (Type III)
ELECTRICAL	Input Voltage	100-277VAC 50/60Hz
	PF	≥0.9
	THD	≤20%
	Driver Model	Daermay MP-100TG130A
	Optional Accessory	P hotocell / S urge protector/ M otion sensor/S ocket/Zhaga interface
MATERIALS	LED Brand	Bridgelux
	LED Type	3030
	LED QTY	120PCS
	Housing	Aluminum Alloy
	Housing Color	Black / Brown/white/Customized
	Waterproof Rating	WET (IP65)
OTHERS	Operating Temperature	-40°C TO 50°C
	Operating Humidity	10%-90% RH
	Storage Temperature	-40°C TO 80°C
	Storage Humidity	10%-95% RH
	Warranty Time	5 Years

PACKAGE

Stent Type	Lamps Net Weight	Size	Qty/ Carton	Weight/ Carton
AM	4.6Kg	720*397*155MM	1	5.5Kg
DM	5.2Kg	720*397*155MM	1	6.1Kg
YM1	4.7Kg	720*397*155MM	1	5.6Kg
UB	5.1Kg	720*397*155MM	1	6.0Kg
FM	4.4Kg	720*397*155MM	1	5.3Kg

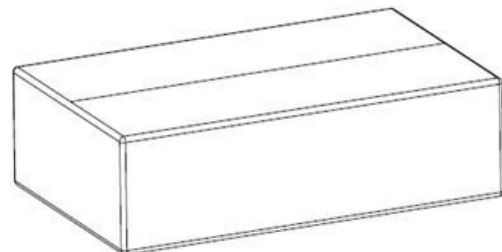
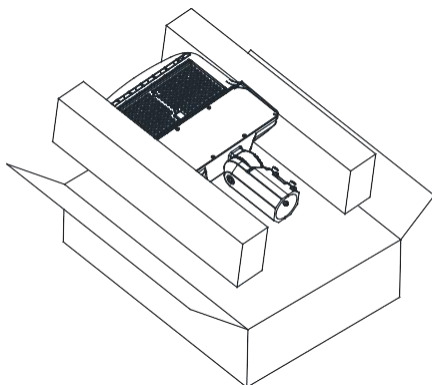

LIGHT DISTRIBUTION TESTING PARAMETERS

Luminaire Property

Luminaire Manufacturer:

Voltage: 119.7 V

Power: 100.59 W

Current: 0.834 A

Power Factor: 0.998

Photometric Results

IES Classification: Type III

Total Rated Lamp Lumens: 13301.1 lm

Efficiency: 100%

Upward Ratio: 0%

Central Intensity: 243.14 cd/klm

Pos of Max. Intensity: H170 V68

Longitudinal Classification: Medium

Measurement Flux: 13301.1 lm

Downward Ratio: 100%

Luminaire Efficacy Rating (LER): 130.98

Max. Intensity: 355.71 cd/klm

Luminous Intensity Distribution Curve

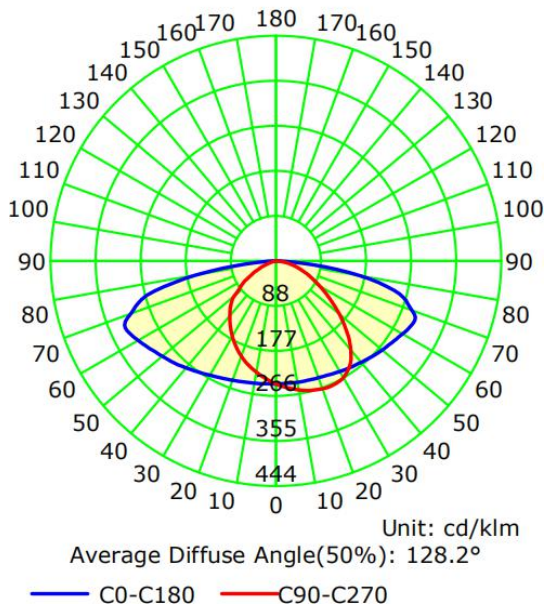

Illuminance at a Distance

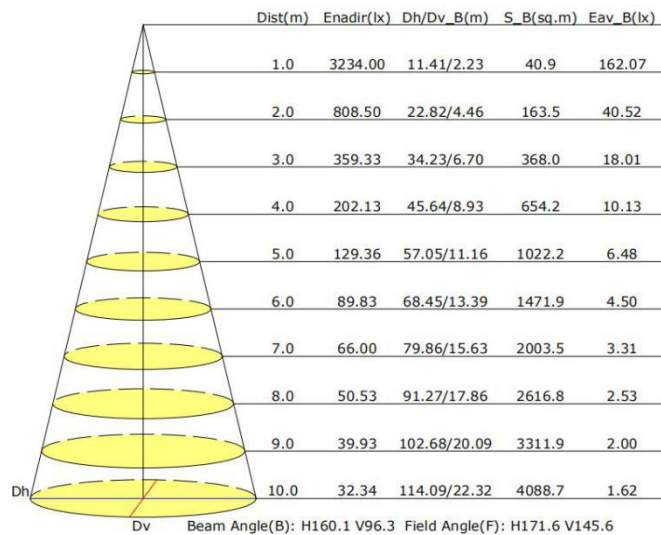

NOTICE FOR USER

- Please turn off power before install or change assembly parts.
- The input voltage and lamps should be matched, after connecting the power line, Please make sure the wiring section is insulated.
- No-professionals, must not install and disassemble the lamps.

TROUBLE SHOOTINGS

Troubles	Check points
Flickering of the light	Turn off the power and turn on again in 3 minutes. If same phenomena occur, then call agencies.
Out of working	Please check the connection.