

4014 SEAMLESS LIGHTBAR

GT-CAB7 Cabinet Light

PART NO: GT-CAB7

FEATURES

- Seamless joint strip
- High lighting effect, 4014 high brightness LEDs
- Small size, 5m can be connected in maximum
- Magnetic or mount holder, convenient to install
- No light spot design
- 3 yr warranty

APPLICATION

- Cabinets
- Exhibition Frames
- Storage Shelf
- Wardrobe Shelf
- Bookcase



4014 SEAMLESS LIGHTBAR

GT-CAB7 Cabinet Light



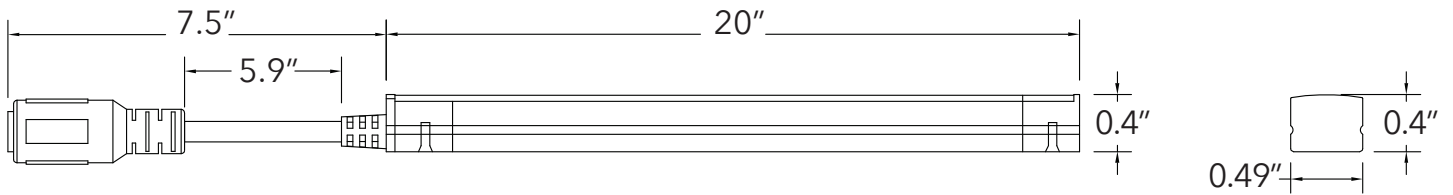

DIMENSIONS



TECHNICAL PARAMETERS

| MODEL | COLOR | LUMEN | LED TYPE | LED QTY | LENGTH | DC VOLTAGE | RATED WATT | RATED CURRENT | BEAM ANGLE |
|-------|---------------|-------|----------|---------|--------|------------|------------|---------------|------------|
| | White | 920 | 4014 | 84 | 512 | 12 | 7.56 | 0.63 | 120° |
| | Neutral White | 870 | | | | | | | |
| | Warm White | 820 | | | | | | | |

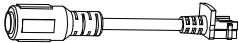
TECHNICAL PARAMETERS

| NAME | MOUNT HOLDER | SCREW | END CAP | CONNECTION WIRE | MIDDLE CONNECTION WIRE (OPTIONAL) |
|---------|---|---|---|---|---|
| DRAWING |  |  |  |  |  |
| QTY | 2pcs | 2pcs | 1pcs | 1pcs | |



4014 SEAMLESS LIGHTBAR

GT-CAB7 Cabinet Light

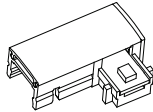
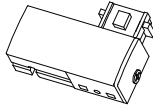
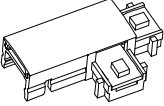
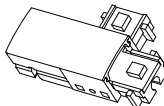
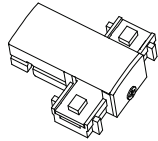
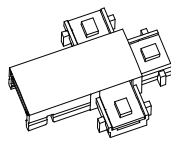
| | | | | | |
|----------------|---|----------|-----------------|---|----------|
| Left Adapter |  | Optional | Right Adapter |  | Optional |
| left T Adapter |  | Optional | Right T Adapter |  | Optional |
| end T Adapter |  | Optional | Cross Connector |  | Optional |

INSTALLATION DIAGRAM

I. Holder Installation

step 1: Pull a parallel string where the LED strip will be installed;

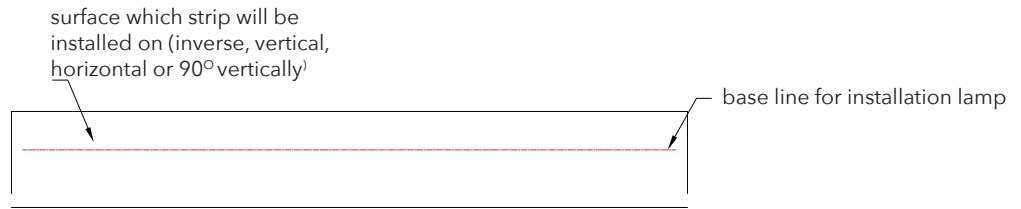

As Figure 1



As Figure 2

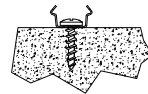

As Figure 3

step 2: Fix mounting clamps on the base line, and the distance depend on practical situation;



4014 SEAMLESS LIGHTBAR

GT-CAB7 Cabinet Light

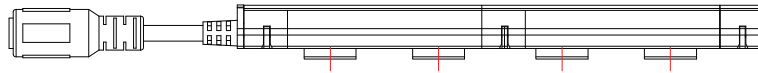

step 3: After the clamp is fixed, snap the groove of strip bottom into the clamp

As Figure 4

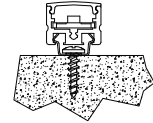

As Figure 5

II. Magnet Adsorption Installation

There is magnet in the LED strip bottom; can be directly adsorbed on the surface of iron products, quick to install.

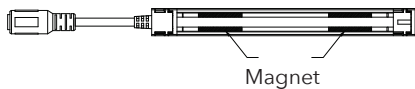

Magnet

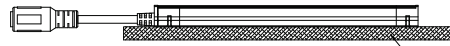

Iron Products

First confirm the installation position of LED strip, after one has been installed, joint another. Connecting before installation is not permitted. 5m can be connected in maximum.

Strip Connection Step

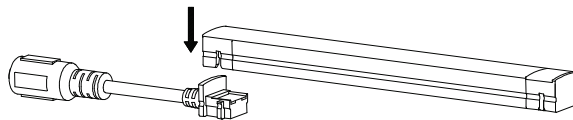

1. Snap the front plug into wire socket from top-down, when connecting another strip, the end cap needs to be removed first;

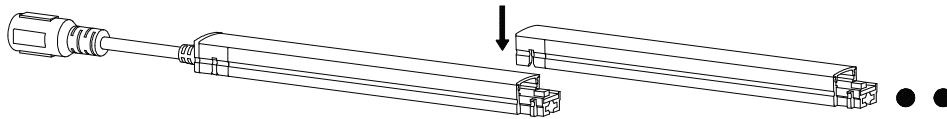

2. Snap the front plug of the second strip into the first strip, then connected in turn;

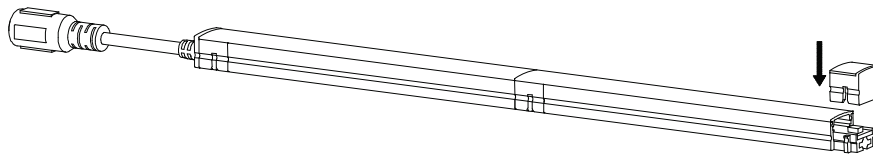

3. When connecting to the last strip, cover the components of end cap and connect;



4014 SEAMLESS LIGHTBAR

GT-CAB7 Cabinet Light

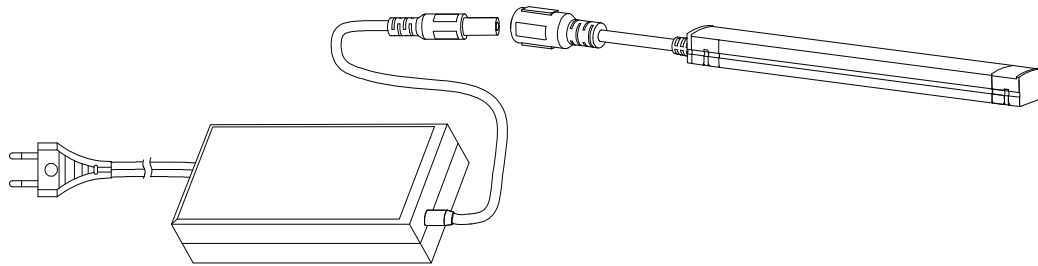

4. Finally connect to power supply, installation finish.

PACKING INSTRUCTIONS

Put the LED strip into electrostatic bag, then put the electrostatic gab into the carton.

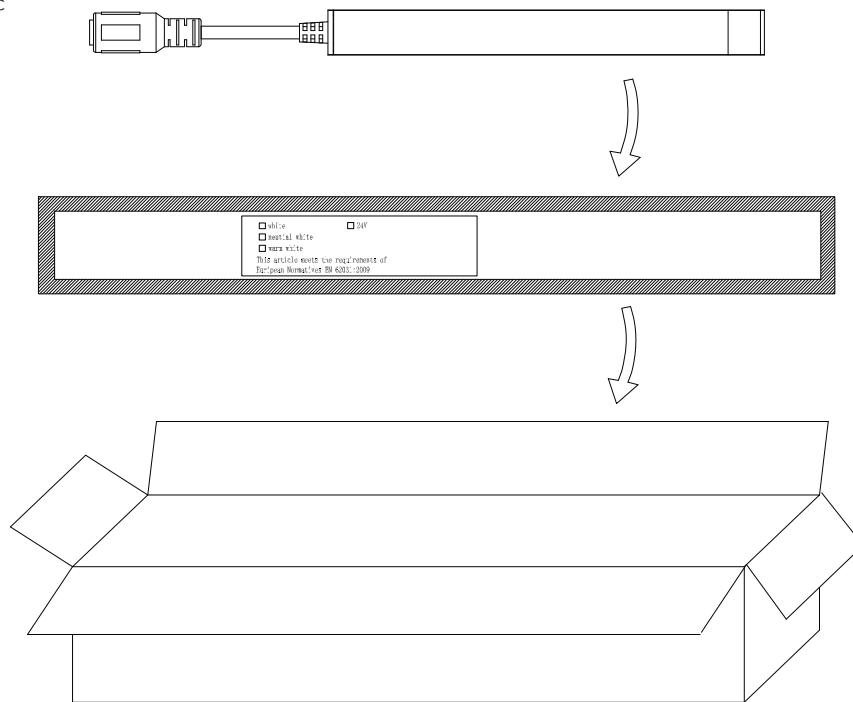

4014 SEAMLESS LIGHTBAR

GT-CAB7 Cabinet Light

INSTALLATION REQUIREMENTS

1. Please read the product specifications carefully, make sure operating environment conform to conditions in specifications in order to be used.
2. Correct electrical polarities need to be observed. Wrong polarity may damage the strip.
3. Confirm input voltage before using and power off.
4. Pay attention to the standard ESD precautions when installing the strip.
5. The length of serial connection can not exceed 5m, LED strip can not exceed 10 pieces.

WARRANTY

This product has a warranty for a period of 3 years from the date of purchase. The warranty is invalid in the case of improper installation, tampering, or removal of the Q.C. date label. Installation in an improper working environment or installation not according to the current edition of the National Electric Code also invalidates the warranty. Should this product fail during the warranty period, it will be replaced free of charge, subject to correct installation and return of the faulty unit. Greentek Energy Systems does not accept responsibility for any installation costs associated with the replacement of this product. This warranty is in addition to the statutory rights in the country of purchase. Greentek Energy Systems reserves the right to alter specifications without prior notice.

