

LED PARKING GARAGE LIGHT

75W

PART NO: GT-PG02-75WAANA1-57K

DESCRIPTION

The LED Canopy Light series can be used for all different applications. These are great for saving energy in common places such as, parking garages, warehouses, gas station, outdoor walkways, and underground parking lots.

The fixture uses high quality LED chips with Philips LUMILEDs that have great illumination. Furthermore, these LED Powered Canopy Lights provide soft uniform light, which is a great safety feature for the eyes. Also, there is no IR or UV in the beam. These LED Canopy Garage Lights provide easy install and operation. In addition to the great added benefits, this lighting fixture provides a convenient feature such as "InstantStart," and there is none of the annoying Flickering or Humming you get with some outdoor lighting fixtures. Moreover, our LED 75W Canopy Lights provide Eco-Friendly lighting; at reduced cost, without Mercury.

ADVANTAGES

- UL cUL certificate
- IP65 Internal driver, Input voltage 100-277Vac.
- Output constant current lever can be adjusted through output cable with 0-10V.
- No UV or IR in the beam.
- Easy to install and operate.
- Energy saving, Long lifespan.
- Light is soft and uniform, Safe to eyes.
- Instant start, NO flickering, NO humming.
- Green and eco-friendly without mercury.



LED PARKING GARAGE LIGHT

75W

WARRANTY

This product has a warranty for a period of 5 years from the date of purchase. The warranty is invalid in the case of improper installation, tampering, or removal of the Q.C. date label. Installation in an improper working environment or installation not according to the current edition of the National Electric Code also invalidates the warranty. Should this product fail during the warranty period, it will be replaced free of charge, subject to correct installation and return of the faulty unit. Greentek Energy Systems does not accept responsibility for any installation costs associated with the replacement of this product. This warranty is in addition to the statutory rights in the country of purchase. Greentek Energy Systems reserves the right to alter specifications without prior notice.

CERTIFICATION	UL, DLC
WATTS	75W
KELVIN	5700K
LUMENS	9900
LUMEN PER WATT(LPW)	132 LPW
OPERATING HUMIDITY	20%-90% RH
LED	PHILIPS
CRI	>80
POWER FACTOR	≥0.9
INPUT VOLTAGE	100-277Vac 50/60Hz
IP GRATE	IP65 Rated

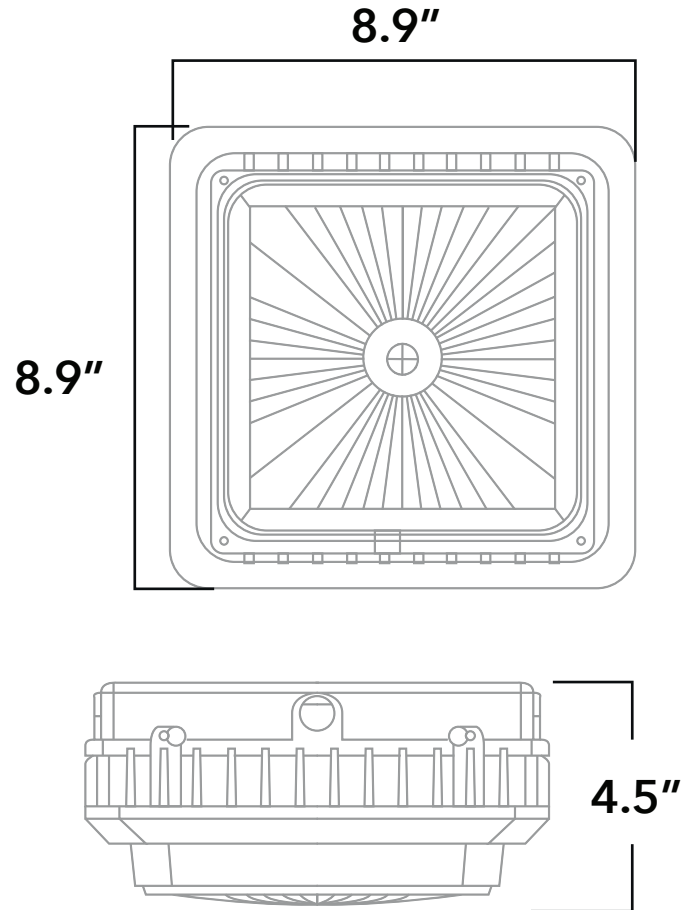

WEIGHT	7.05lbs
HOUSING	Aluminum + PC
HOUSING COLOR	White
COVER	Stripe PC Cover
VIEWING ANGLE	160°
WARRANTY	5 years



LED PARKING GARAGE LIGHT

75W

CAUTION

- Please turn off power before install or change assembly parts.
- The input voltage and lamps should be matched, after connecting the power line,
- Please make sure the wiring section is insulated.
- No-professionals, must not install and disassemble the lamps.

