

# LED REFRIGERATION/COOLER LIGHT

## 5FT TWO-SIDED

### DESCRIPTION

These fixtures are a great replacement for your current 5ft and 6ft lights. These lights are Certified to be safe around foods and drinks and have the proper protection to prevent any moisture from damaging the lights. These lights will replace the existing fixture and come with an Internal Driver. All that is needed is 4 screws to install (2 at the top & 2 at the bottom). Once installed, there will be 2 ways to wire the lights; direct wire or in a series.

### FEATURES

- IP65 Rated light module for use in Commercial Refrigerators and Freezers
- Dramatically improves look of any food or merchandise being displayed
- Energy efficient design significantly reduces cost of ownership- savings up to 75%.
- Light diffuser contains no glass providing zero risk of glass breakage.
- Instant start in cold environments.
- Mercury and Lead Free
- Local utility incentives may be available
- Binned diodes for color uniformity



### WARRANTY

This product has a warranty for a period of 3 years from the date of purchase. The warranty is invalid in the case of improper installation, tampering, or removal of the Q.C. date label. Installation in an improper working environment or installation not according to the current edition of the National Electric Code also invalidates the warranty. Should this product fail during the warranty period, it will be replaced free of charge, subject to correct installation and return of the faulty unit. Greentek Energy Systems does not accept responsibility for any installation costs associated with the replacement of this product. This warranty is in addition to the statutory rights in the country of purchase. Greentek Energy Systems reserves the right to alter specifications without prior notice.

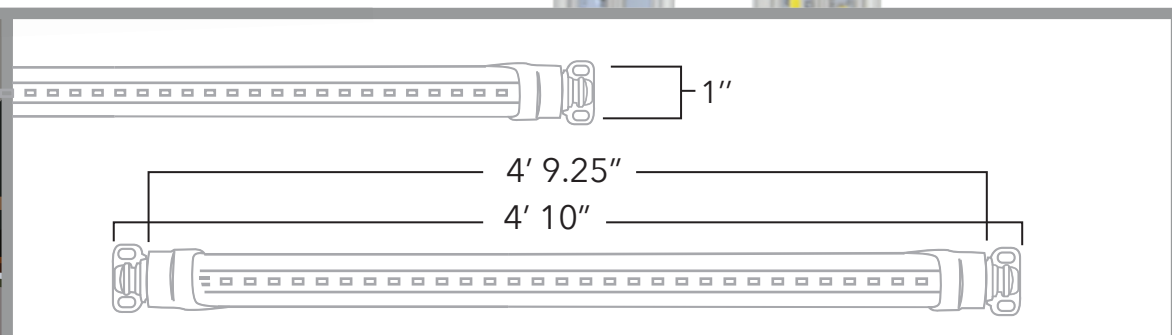

SKU	ZY-22W1500	Frequency	50-60hz	Warranty	3 years
Qualification	UL Listed	Lifespan	50,000 hours	Package	25pc/box
Power	22W	Lumens	2420 Lumens (110 lm/w)	Application	Reach in refrigeration, coolers and freezers, Multi-deck applications, Meat and Fish displays
Color	5700K	Overall Length	4'10"		