

TN Crane Scale

Features

- Capacities - 600, 1500 & 3000kg
- NZ Trade Approved
- Bright LED / LCD Display
- Remote Controller
- 30mm LED/LCD Display
- Light weight and Heavy duty construction
- Internal Rechargeable battery
- Aluminium Diecast Housing
- Zero and Tare Keys
- 125% Safe overload

NZ Trade Approved

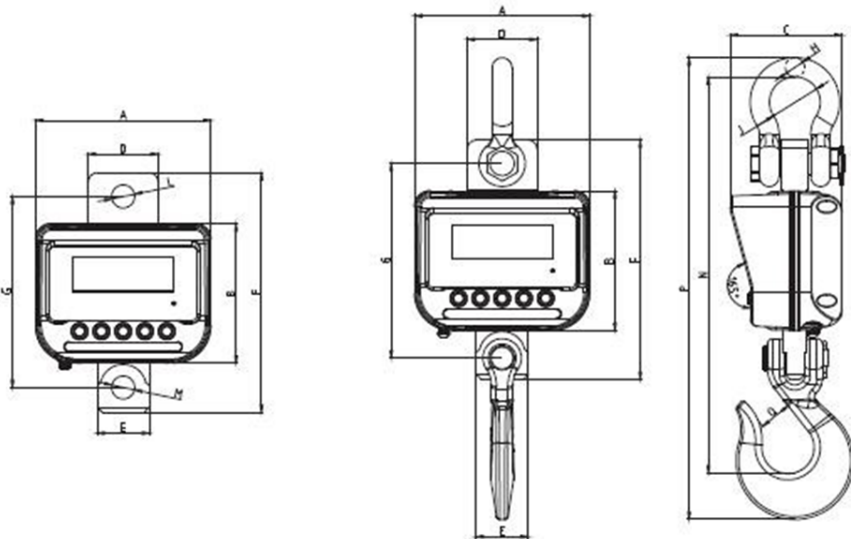

DIM (mm) / CAP	600kg	1.5T	3T
A	201	201	201
B	160	160	160
C	128.5	128.5	128.5
D	80	80	80
E	60	60	60
F	270	270	275
G	219	219	219.5
H	φ 19	φ 19	φ 22
J	φ 50.8	φ 50.8	φ 58
L	φ 23	φ 23	φ 26.5
M	φ 23	φ 23	φ 26.5
N	415	415	456
P	477	477	532
Q	42.9	42.9	50.8



Millennium Mechatronics Limited
 Email: info@meltrons.com | www.meltrons.com

