

MT601 Single Ended Bending Beam



Features

- Fully Welded
- Stainless Steel Construction
- IP68
- Water Proof
- Electroless Nickel Plated
- Low Profile
- High Accuracy
- Simple to install

Applications

Platform Scales, belt scales, packaging machines, Hopper and Silo weighing

Specifications

Capacities	kg	10,20,30,50,100,200,250,350 and 500
Combined error	(%FS)	$\leq \pm 0.020$
Creep	%FS/30min	$\leq \pm 0.017$
Temperature effect on sensitivity	(%FS/10°C)	$\leq \pm 0.010$
Temperature effect on zero	(%FS/10°C)	$\leq \pm 0.017$
Output sensitivity	(mv/v)	2.0 ± 0.005
Input resistance	(Ω)	400 ± 20
Output resistance	(Ω)	350 ± 3.5
Insulation resistance	(M Ω)	$\geq 5000(50VDC)$
Zero balance	(%FS)	2.0
Temperature, Compensated	(°C)	-10°C+40
Temperature, Operating	(°C)	-35°C+65
Excitation, Recommended	(V)	5°C12(DC)
Excitation, Max	(V)	18(DC)
Safe overload	(%FS)	150
Ultimate overload	(%FS)	300

Cable

4 Core, 5mm dia, 3 meter cable

Color Code

Exc+ Green

Exc- Black

Sig+ White

Sig- Red

Dimensions

dia d 8.2 mm(5-300kg). 10.25mm(500kg)

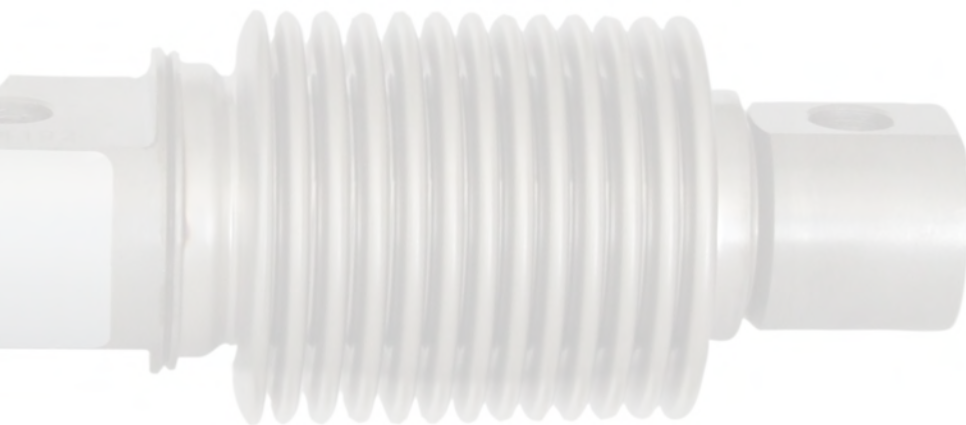
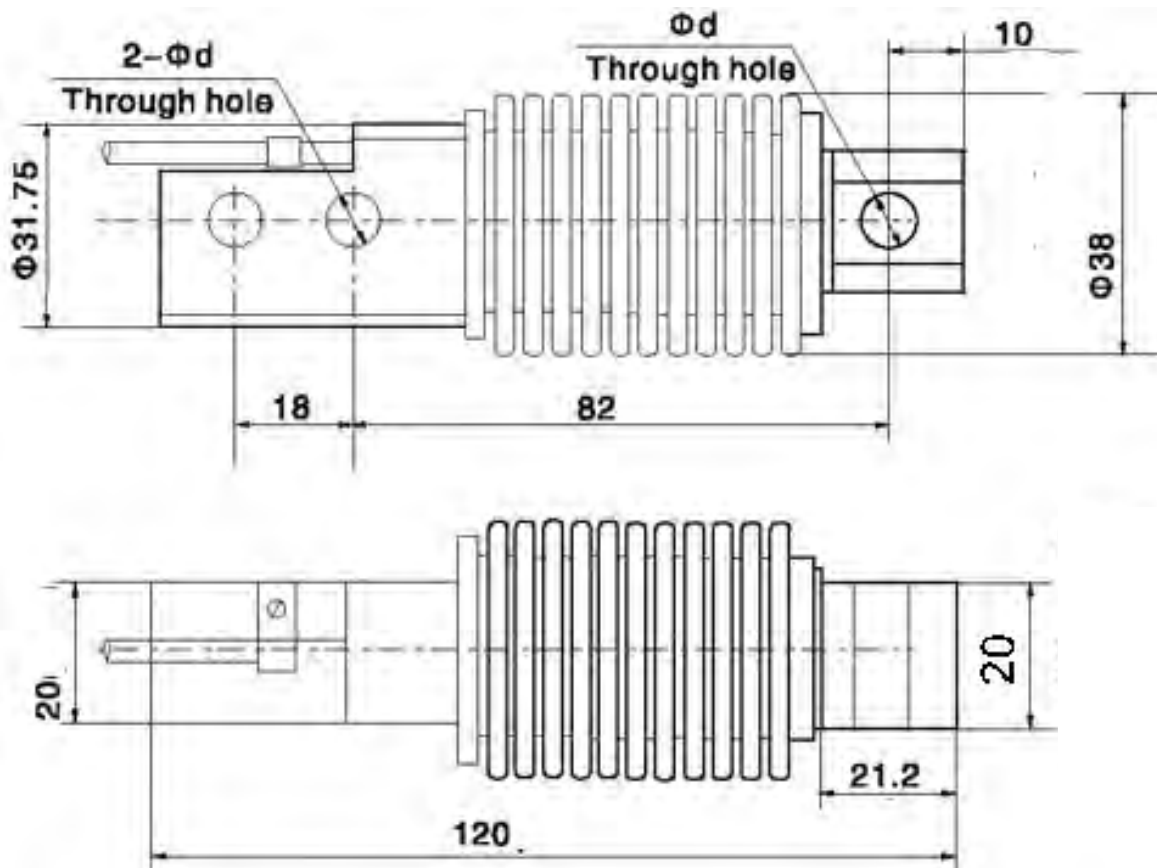

Specifications are subject to change without notice for improvement

MT601Rev1 25092011