



1.2" LED display



Wireless Remote Control

# CASTON-II SERIES

## Crane Scale

CASTON-II is a rugged heavy-duty hanging scale for various industrial environments. The series is applicable in industrial areas including manufacturing factories and also heavy-duty industrial plants. Equipped with a wireless remote control function which makes operation more efficient and safe.

- Trade approved (NMI No. 6/13/4)



# CASTON-II SERIES | Crane Scale

## SPECIFICATIONS

Model	2THB	3THB	5THB
Max. Capacity (kg)	2,000	3,000	5,000
Readability (kg)	1	1	2
External Resolution	1/2,000	1/3,000	1/2,500
Display Digit	5 Digits		
Display Type	LED (1.2 inch)		
Operating Temp.	-10°C~40°C		
Power	DC 12V		
Dimensions (mm)	230(W) x 370(D) x 474(H)		230(W)x 370(D) x 518(H)
Product Weight (kg)	17		20

## FEATURES

- Standard wireless remote controller
- 2x Rechargeable battery packs & charger included
- Battery operated with low battery indication
- on/off, zero, tare, and hold function
- Easy-to-read 1.2" LED display
- Auto span adjustment & zero tracking

## DISPLAY & KEY PAD

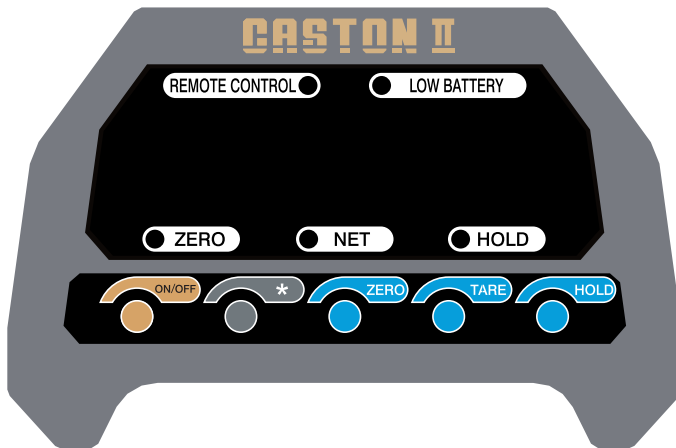

## DIMENSIONS

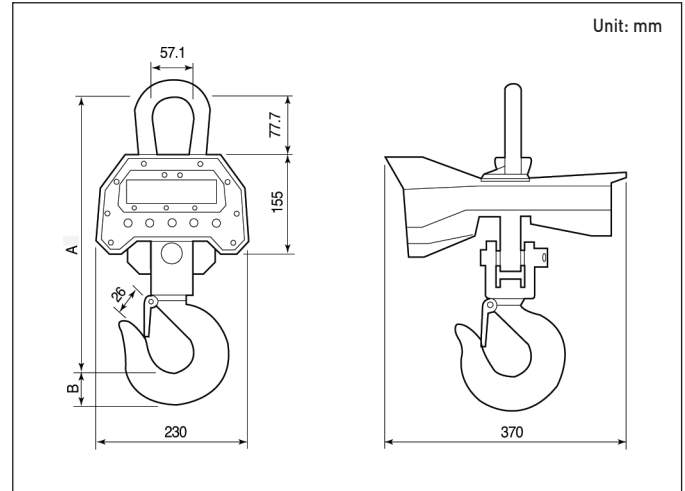

Model	Capacity	Gradustion	A	B	C	D	E	F
0.5 THB	500 kg	200 g	350	57.1	82	30	26	26
1 THB	1 ton	500 g	350	57.1	82	30	26	26
2 THB	2 ton	1 kg	430	57.1	91	47	45	30
3 THB	3 ton	1 kg	430	57.1	91	47	45	30
5 THB	5 ton	2 kg	474	57.1	100	47	45	30

Battery Pack Installation



UNIT 8, NORTHLINK, 459 TUFNELL ROAD  
 BANYO QLD 4014, AUSTRALIA  
 TEL\_ +61 7 3267 7767 FAX\_ +61 7 3267 1818  
 EMAIL\_ sales@casscale.com.au  
[www.cassscale.com.au](http://www.cassscale.com.au)

Specifications are subject to change for improvement without prior notice.