



# INSTALLATION INSTRUCTIONS

**Legato Performance Exhaust Kit #LEX4220**  
**For 2005-'10 Dodge Charger R/T, Magnum R/T,**  
**Chrysler 300C, all w/5.7L V8 - Includes 4WD**  
**409 Stainless Steel w/304 Stainless Steel Tips**

### Removal of Stock System:

1. If a hoist or rack is available, raise the vehicle to a comfortable working height. If no lift is available you can jack up the vehicle and support it with jackstands. Make sure that the vehicle is safely positioned on the jackstands before getting under it.
2. Apply a lubricant to the rubber hanger rods/mounts that support the mufflers. This will ease the removal and installation.
3. With a 13MM socket, unbolt the left tailpipe assembly at the flanged connection at the rear of the muffler. Slide the three hanger rods out of the rubber mounts on the vehicle and remove the left tailpipe assembly.
4. Using a 13MM socket, unbolt the body brace between the catalytic converters and the muffler assembly. Save the brace and the four nuts for reinstallation.
5. Support the right side muffler with a stand and loosen the clamps at the slip fit connection to the catalytic converters. Remove the three remaining hanger rods from the rubber mounts and slide the entire remaining system back off the headpipes.

### Installation of the Legato System:

1. Before installing anything, prep the clamps supplied with the Legato system by removing the nuts and applying a thick lubricant such as white grease or anti-seize compound to the threads.
2. Place two supplied clamps at the front end of the scavenger pipe assembly (#4220-3). Then slide the scavenger pipe onto the head pipes. Level and center the scavenger pipe assembly in the drive

line tunnel and support with a stand. Tighten the two clamps enough to hold but still allow for adjustment. Then reinstall the body brace making sure there is clearance between scavenger pipe (4220-3) and the cross-member.

3. Place a supplied clamp onto the inlet of each muffler. Then slide the mufflers onto the scavenger pipe one at a time, and support them with stands. Level the mufflers and tighten the clamps enough to hold but still allow some adjustment.
4. Place a supplied clamp onto the left muffler outlet. Place the left tailpipe into position and slide the hanger rods into the factory rubber mounts. Slide the tailpipe into the muffler outlet. Rotate so hangers are level and lightly tighten clamps enough to hold but allow adjustment. Repeat this step for the right tailpipe.
5. Slide the stainless tips onto the outlet of the tailpipes. Adjust for good fit and lightly tighten to allow for later adjustment.
6. Adjust the position of all the pipes and the mufflers to provide a satisfactory fit. A minimum of 1/2-inch of clearance around all parts of the system must be maintained while considering suspension travel and vibration in mind. Pay close attention to the area around the body brace. It is recommended to jack, or lift up the scavenger pipe assembly before tightening to assure proper clearance. After you are satisfied with the positioning of all the parts, the clamps can be securely tightened throughout the entire system.
7. After the system is secure, slide the #4000-6 hanger keepers onto the ends of each hanger rod to prevent the rods from slipping out of the rubber mounts.

**100%  
Stainless  
Steel**

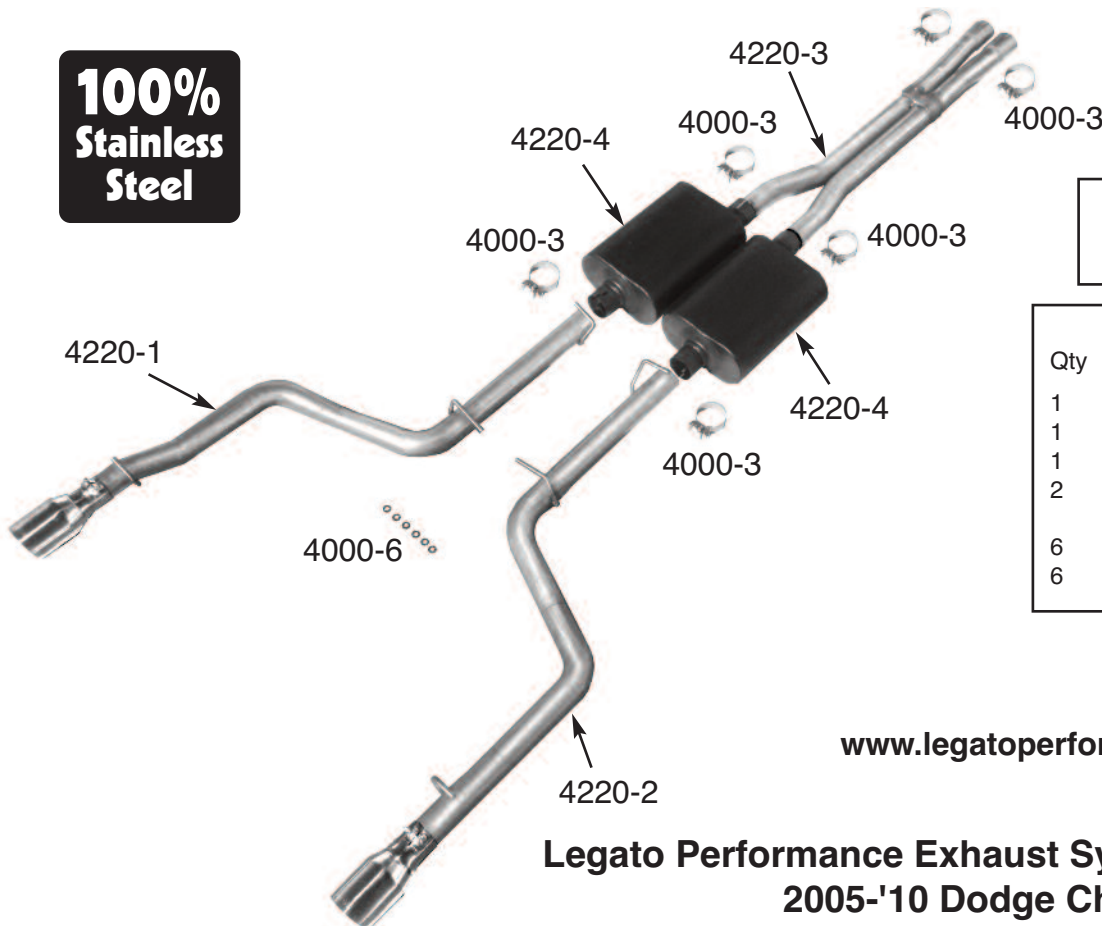

**Technical Support**  
**661-578-5448**

KIT CONTENTS		
Qty	Description	Pt. No.
1	Tailpipe (Right)	4220-1
1	Tailpipe (Left)	4220-2
1	Scavenger Assy	4220-3
2	Muffler	4220-4
Parts Kit		
6	2-1/2" Clamps	4000-3
6	Hanger Keepers	4000-6

[www.legatoperformance.com](http://www.legatoperformance.com)

**Legato Performance Exhaust System #LEX4220 for**  
**2005-'10 Dodge Charger**