



INSTALLATION INSTRUCTIONS

Legato Performance Exhaust Kit #LEX4142
For 2016 Chevrolet Camaro w/6.2L V8
W/O Dual Mode Exhaust - Includes Convertible
409 Stainless Steel w/304 Stainless Steel Tips

Removal of Stock System:

1. If a hoist or rack is available, raise the vehicle to a comfortable working height. If no lift is available you can jack up the vehicle and support it with jackstands. Make sure that the vehicle is safely positioned on the jackstands before getting under it.
2. Apply a lubricant to the four rubber hanger rods/mounts that support the mufflers. This will ease the removal and installation.
3. Measure back 1-1/2" from the back side of the rear suspension crossmember. See photo #1 on back of this page. Do this on both pipes and make a mark at your measurement. You are going to cut both pipes at this mark. Support the pipes before and after the cut so that they do not fall when the cuts are made. After double checking your measurement cut both pipes at your mark. Use caution when cutting.
4. After cutting the two pipes and with the factory muffler still supported, slide the two hangers at the front of the muffler from the rubber mounts on the vehicle. Now lower the supports at the front of the muffler and slide the muffler forward to release the rear hangers from the mounts on the vehicle. Lower the muffler and set aside. Deburr the end of the pipes where cut with a file or die grinder. Using a 15mm wrench, unbolt the two stock hangers at the rear of the vehicle from the frame. See Figure 2. When you remove them, place them with the corresponding

side of the factory muffler. See additional photo on next page.

Installation of the Legato System:

1. Place the new Legato muffler units next to the factory unit and swap the rear hanger mounts (Figure 2) from the stock muffler to the Legato muffler assemblies.
2. Slide a provided 2-3/4" clamp onto the factory inlet pipes, then place the right muffler assembly #4142-2 up into position and slide the inlet onto the factory pipe approximately 2.50" to 3.00". Support the assembly with a stand and remount the rear hanger mount to the frame, tighten securely. Then, connect the hanger at the front of the muffler to the rubber mount on the vehicle. Leave the clamp on the inlet loose for now. Repeat this step with muffler assembly #4142-1 on the left side of the vehicle.
2. Adjust and level the two muffler assemblies to provide a satisfactory fit. They can also be adjusted forward or back to get the desired position in the rear valance cut-outs. A minimum of 1/2" clearance around all parts of the system must be maintained; while keeping suspension travel and vibration in mind.

(Continued on back page)

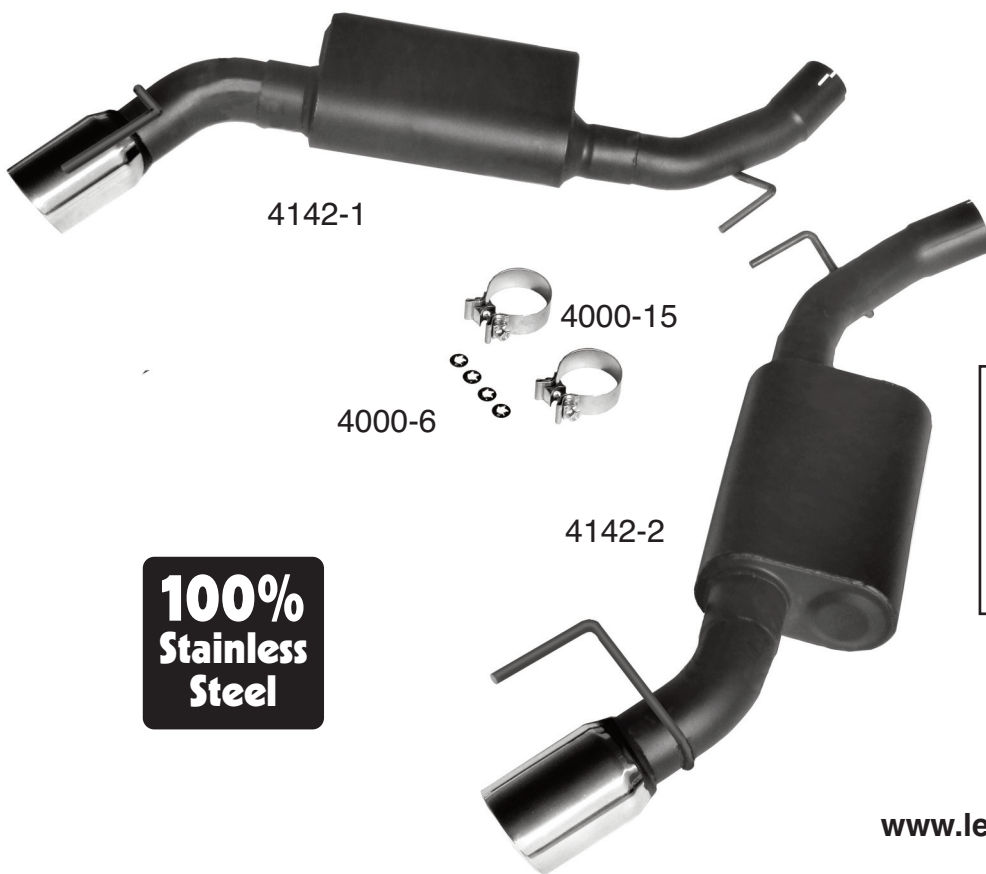

**100%
Stainless
Steel**

Technical Support
661-578-5448

KIT CONTENTS		
Qty	Description	Pt. No.
1	Muffler (Left)	4142-1
1	Muffler (Right)	4142-2
Parts Kit		
2	2-3/4" Clamps	4000-15
4	Hanger Keepers	4000-6

www.legatoperformance.com

After adjustments have been made, and you are satisfied with the fit, you may now securely tighten the two muffler inlet clamps.

4) For a more secure installation, we highly recommend placing a minimum 1" weld on either side of the inlet slip-fit connections. Place the included 7/16" hanger keepers onto the ends of the hangers at the front of each muffler and slide up to the rubber mount, these will prevent

the hangers from slipping out of the rubber mounts.

TIP: An easy way to install the hanger keepers is to select a deep socket that is just slightly smaller in diameter than the hanger keeper. Push the hanger keeper onto the end of the hanger rod and then using a hammer and the deep socket, tap the keeper into position.

Note: Before making any cuts, position the new Legato exhaust pipe into position to confirm that you are cutting in the correct position. Also note that your pipes may not look exactly like the ones in the photo as this is the dual mode system. While the Legato kit will not work with the dual mode exhaust, this photo does accurately show the position of the cuts relative to the crossmember.

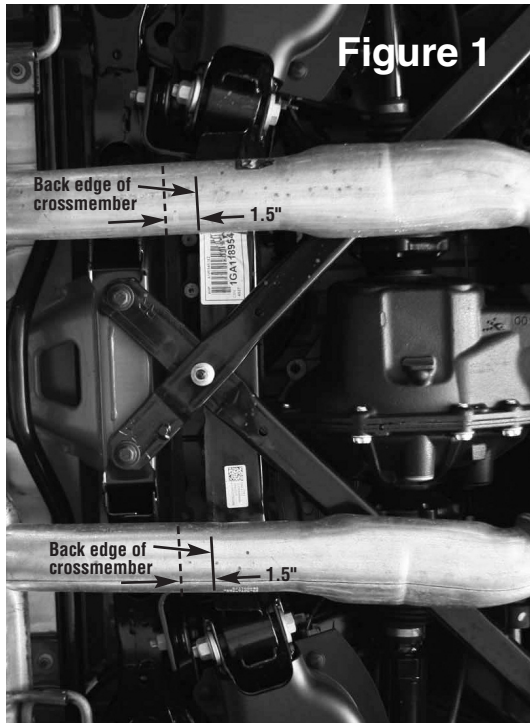

Figure 1

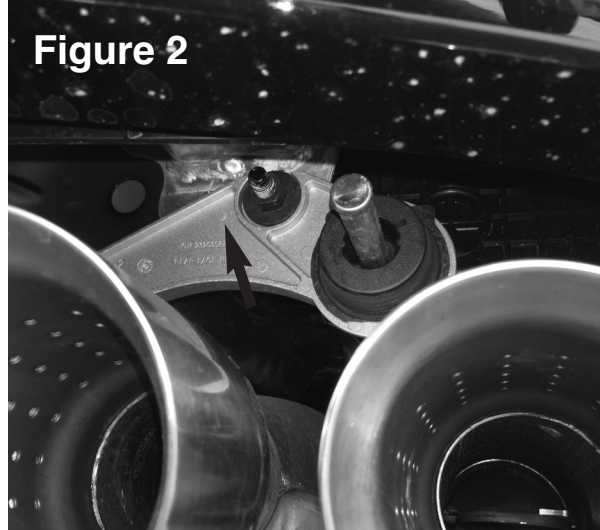

Figure 2

After removing stock exhaust, also remove both hanger brackets (see arrow). There is a left and a right so make sure you don't mix them up. We suggest marking the brackets with a felt tip pen.

Measure back from the back edge of the crossmember 1-1/2-inches. Cut both pipes at the dotted line. Make sure everything is supported properly when making the cuts so the parts do not fall to the floor.

Lifetime Limited Warranty on Legato Exhaust Systems

Legato extends the following limited warranty to the original purchaser of a Legato exhaust system. Legato warrants its exhaust products against defects in materials and workmanship for the buyer's lifetime from the date of original purchase. This applies only to the original purchaser and the parts must remain installed on the original vehicle for which they were purchased. This warranty is void if the product was improperly installed, was installed on a vehicle for which it was not designed, if it was modified in any manner, or was removed from the original vehicle and reinstalled on another vehicle.

This warranty shall not apply to any product installed on a racing vehicle, installed improperly, or contrary to Legato's instructions, altered, misused, or repaired or damaged from an accident, collision, or willful or negligent act. To make a claim under the terms of this Warranty, the original purchaser must return the product to Legato along with proof of original purchase. Purchaser must call Legato (661-578-5448) to obtain a Returned Material Authorization (RMA). Proof of purchase must clearly show the place of purchase, purchase price, product purchased and date of purchase.

If, upon inspection, Legato determines a defect in materials or workmanship, Legato will refund the returned goods shipping expense, and replace the defective part or parts with a new part or parts.

LEGATO'S LIABILITY IS EXPRESSLY LIMITED TO THE PAYMENT OF SHIPPING COSTS AND REPLACING THE DEFECTIVE PART OR PARTS. LEGATO WILL HAVE NO LIABILITY FOR THE COST OF INSTALLATION OR THE REMOVAL OF THE DEFECTIVE PRODUCT OR FOR THE COST OF LABOR OR ANY ADDITIONAL PARTS REQUIRED TO COMPLETE THE INSTALLATION OF THE REPLACEMENT PRODUCT.

IN NO EVENT WILL LEGATO BE LIABLE FOR ANY INDIRECT, SPECIAL, INCIDENTAL OR CONSEQUENTIAL LOSSES OR DAMAGES (INCLUDING BUT NOT LIMITED TO INTERRUPTION OF BUSINESS OR LOSS OF BUSINESS OR PROFIT) RESULTING FROM THE USE OR INABILITY TO USE THE PRODUCT, ANY BREACH OF WARRANTY, OR ANY DEFECT IN THE PRODUCT, EVEN IF LEGATO SHALL HAVE BEEN ADVISED OF THE POSSIBILITY OF SUCH POTENTIAL DAMAGES OR LOSSES. SOME STATES DO NOT ALLOW THE EXCLUSION OR LIMITATION OF INCIDENTAL OR CONSEQUENTIAL DAMAGES, SO THE ABOVE LIMITATION OR EXCLUSION MAY NOT APPLY TO YOU. THIS WARRANTY GIVES YOU SPECIFIC LEGAL RIGHTS. YOU MAY ALSO HAVE OTHER RIGHTS WHICH VARY FROM STATE TO STATE.