



CABINE STORAGE CABINET

A nod to sensibilities of sustainable living and Japanese Ryokan design, the understated Cabine unit is designed to seamlessly adapt to any room of the house.

The small Cabine is right at home in apartments, bedrooms and smaller spaces whilst still looking generous, with four internal compartments. The large Cabine, with its low profile, is right at home behind a sofa to display your favourite treasures or as a standalone media unit, creating the ultimate calm space while you watch your favourite series. Cabine can also be wall-mounted without legs for a flexible and floating storage system.



DESIGNED
BY PLYROOM



SUSTAINABLY
FORESTED



MADE IN
AUSTRALIA

SPECIFICATIONS



MATERIALS

Sustainably forested European birch or American oak with Tasmanian oak legs.. Protected with plant based satin finish.

- Birch
- American Oak



SUSTAINABILITY

FSC Certified European birch plywood
FSC Certified American oak plywood
FSC Certified Tasmanian oak
Plyroom is a member of 1% for the Planet



CRAFT

Designed by Plyroom
Made in Australia



WARRANTY

A 2 year warranty covers the structural integrity of Plyroom products.

WEIGHT + DIMENSIONS

Small

Assembled 22kg w 1200 x d 390 x h 680mm

Large

Assembled 32kg w 1500 x d 390 x h 680mm

Low

Assembled 26kg w 1500 x d 390 x h 500mm

Packaged

This item is delivered assembled. Package size reflects the production dimensions.

ASSEMBLY

Assembly not required.

CARE

For general care we recommend regular dusting with a clean, dry cloth, or wiping down with soft cloth wrung dry from plain water (leaving the surface dry after cleaning). Common stains can be removed with a damp cloth and should be attended to as soon as possible.

Solvents or direct heat will cause damage to your timber furniture.

DIMENSIONS

MEASURED IN MM

CABINE SMALL

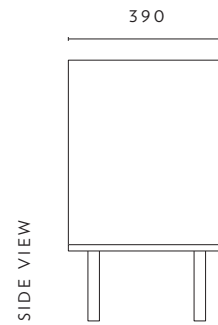
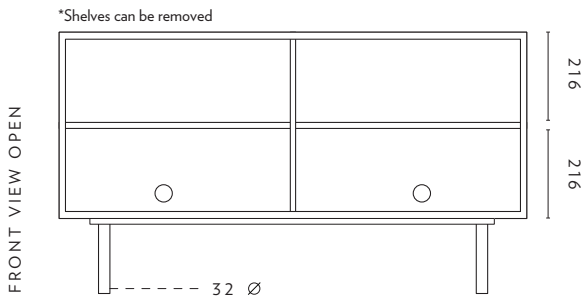
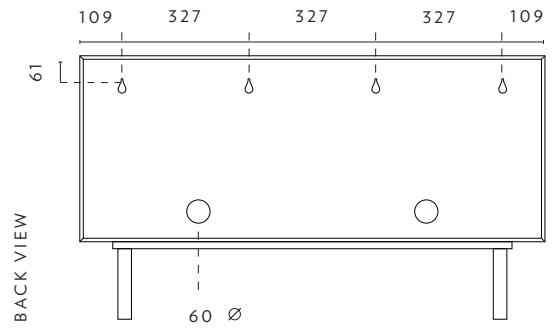
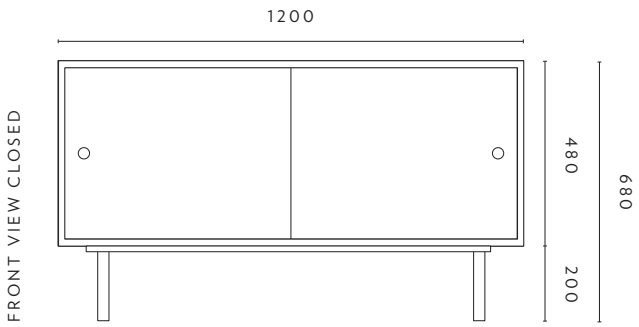

CABINE LARGE

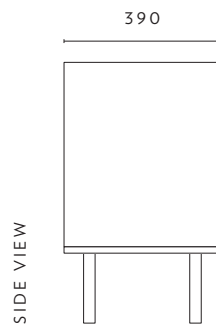
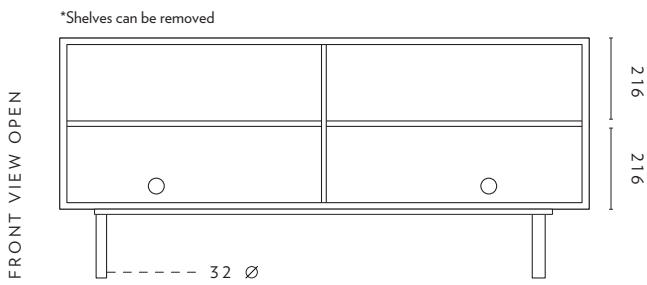
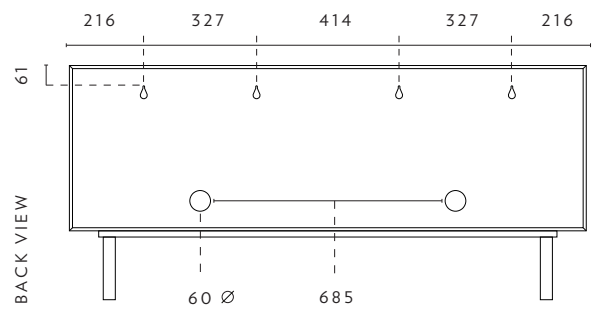
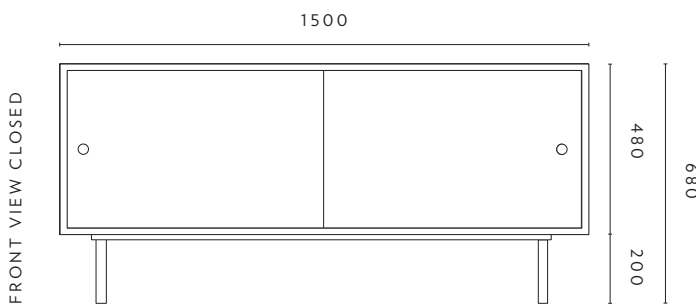

DIMENSIONS

CABINE LOW

