



Instruction Manual
For
Ronin Lift
PN 2805-11
"Original Instructions"



WARNING

To avoid electrical shock, do not open the Ronin Lift's front cover. Refer servicing to qualified personnel only.

Caution

Modification of controls or adjustment of performance, other than specified by procedures herein, may results in injury or death.

You are cautioned that any changes or modifications, not expressly approved by the party responsible for compliance, could void the user's authority to operate the equipment.

If you have questions about this product, visit www.changeyourelevation.com/contact/ or contact Ronin Customer Service at +1-657-444-2557. You can also write to,

Ronin Revolution Corporation
Customer Service/Technical Support
600 S. Jefferson St Suite D
Placentia CA 92870 USA

Declaration of Conformity

Trade Name:	Ronin Lift
Model No.:	2805-11
Responsible Party:	Ronin
Address:	600 S. Jefferson St Suite D Placentia CA 92870 USA
Telephone:	+1-657-444-2557

This device complies with Part 15 of FCC Rules and Industry. Canada license-exempt RSS standard(s). Operation is subject to the following two conditions: (1) this device may not cause harmful interference, and (2) this device must accept any interference received, including interference that may cause undesired operation.

About lithium ion battery

The lithium ion battery used to power this product contains Perchlorate. The following statement is required by the state of California, USA:

Perchlorate Material – special handling may apply. See <http://www.dtsc.ca.gov/hazardouswaste/perchlorate>

Contents

Warning	2
About Lithium Ion Battery	3
Precautions	5
Product Overview	7
Specifications	9
Box Contents	11
Ronin Lift Device Labels	12
Charging Instructions	15
Rope Requirements	16
Battery Installation & Motor Initiation	17
Loading Rope	18
Operating Ronin Lift	20
Ronin Lift Duty Cycle	24
Inspection and Maintenance	25
Inspection and Log Sheet	26
End of Life	27
Warranty	28

Precautions

Before using this product, carefully read this manual and retain it for future reference. Parents and guardians of children should read this manual and make sure that the child follows all safety precautions.

Safety

This product has been designed with the highest concern for safety. However, any electro-mechanical device, if used improperly, has the potential for causing fire, electrical shock or personal injury. To help ensure accident-free operation, follow these guidelines:

- Observe all warnings, precautions and instructions
- Regularly inspect AC power cord for damage
- Do not leave any charging battery unattended
- Unplug charging battery immediately, once charge is complete
- Stop use, unplug AC power cord from electrical outlet immediately if the device functions in an abnormal manner, produces unusual sounds / smells, becomes too hot to touch, or battery becomes swollen / bloated
- Do not handle damaged or leaking lithium-ion batteries
- Do not allow the battery to come into contact with fire or subject to extreme temperatures such as direct sunlight, in a vehicle exposed to sun or near a heat source

Prior to using Ronin Lift Personal Ascender please ensure you properly inspect all gear and accessories. To learn more about proper safety precautions please visit the following websites:

Use & Handling

- Do not use Ronin Lift without the proper safety equipment. Not doing so may cause serious injury or death
- Only use approved static ropes with Ronin Lift personal ascender
- Do not overheat the DC motor. If motor becomes extremely hot discontinue use until motor has cooled down
- Inspect all equipment prior to each use, including Ronin Lift, safety harness, carabineer clips, static rope, and helmet.
- Only use safety rated carabineer clips with Ronin Lift
- Do not wet or submerge Ronin Lift. Ronin Lift is IP54 rated and not waterproof.
- Be careful when carrying the Ronin Lift, if you do not have a good grip, the device may drop causing potential damage or injury
- Do not stand on or put objects on the device, and do not stack the device with other devices
- Keep the device, accessories, and any small components out of reach of small children
- Stop using the device immediately if you begin to feel tired or if you experience discomfort or pain in your hands, arms or legs while operating the device

- If you experience any of the following health problems, discontinue use of the device immediately. If symptoms persist, consult your doctor.
 - Dizziness, nausea, fatigue or symptoms similar to motion sickness
 - Discomfort or pain in a part of the body, such as hands, arms or legs
- Do not place device on the floor or in a place where it may cause someone to trip, stumble or fall
- Do not expose the device to high temperatures or high humidity
- Do not use device in an electrical storm
- Do not touch connectors on device
- Do not rest the device on any surfaces that are unstable, tilted or subject to vibration
- Do not allow liquid, small particles or other foreign debris to enter the device

Vents

Do not block any motor vents. To maintain good ventilation, follow the guidelines below:

- Do not cover motor ventilation holes
- Do not allow dust to build up on the motor vents
- Do not allow foreign debris to cover the motor vents

AC Power Cord Use

- Do not plug in AC power cord without verifying electrical outlet compatibility. Check AC power supply connected to AC power cord for power outlet compatibilities
- To help ensure safe operation, regularly inspect the AC power cord. If damaged, stop use immediately and contact customer support.
- Do not modify the cord
- Do not use a power cord other than the supplied AC power cord
- Do not touch the AC power cord with wet hands
- Protect the AC power cord from being walked on or pinched particularly at plugs, expansion receptacles and the point where the cords exits the power supply
- Do not place heavy items on the AC power cord
- Do not place the AC power cord near heating equipment and do not expose the cord to heat
- Unplug the AC power cord from the electrical outlet when you do not intend to use the charger. When disconnecting, grasp the AC power cord by the plug and pull straight out of the electrical outlet. Never pull by the cord and do not pull out at an angle.
- Do not connect AC power cord to a voltage transformer or inverter.

Moisture & Condensation

If the device is brought directly from a cold location to a warm one, moisture may condense either on the electronics or motor. Should this occur, the device may not operate properly. In this case, remove the battery until moisture evaporates from the

device (this may take several hours). If the device still does not operate properly contact customer service.

Product Overview

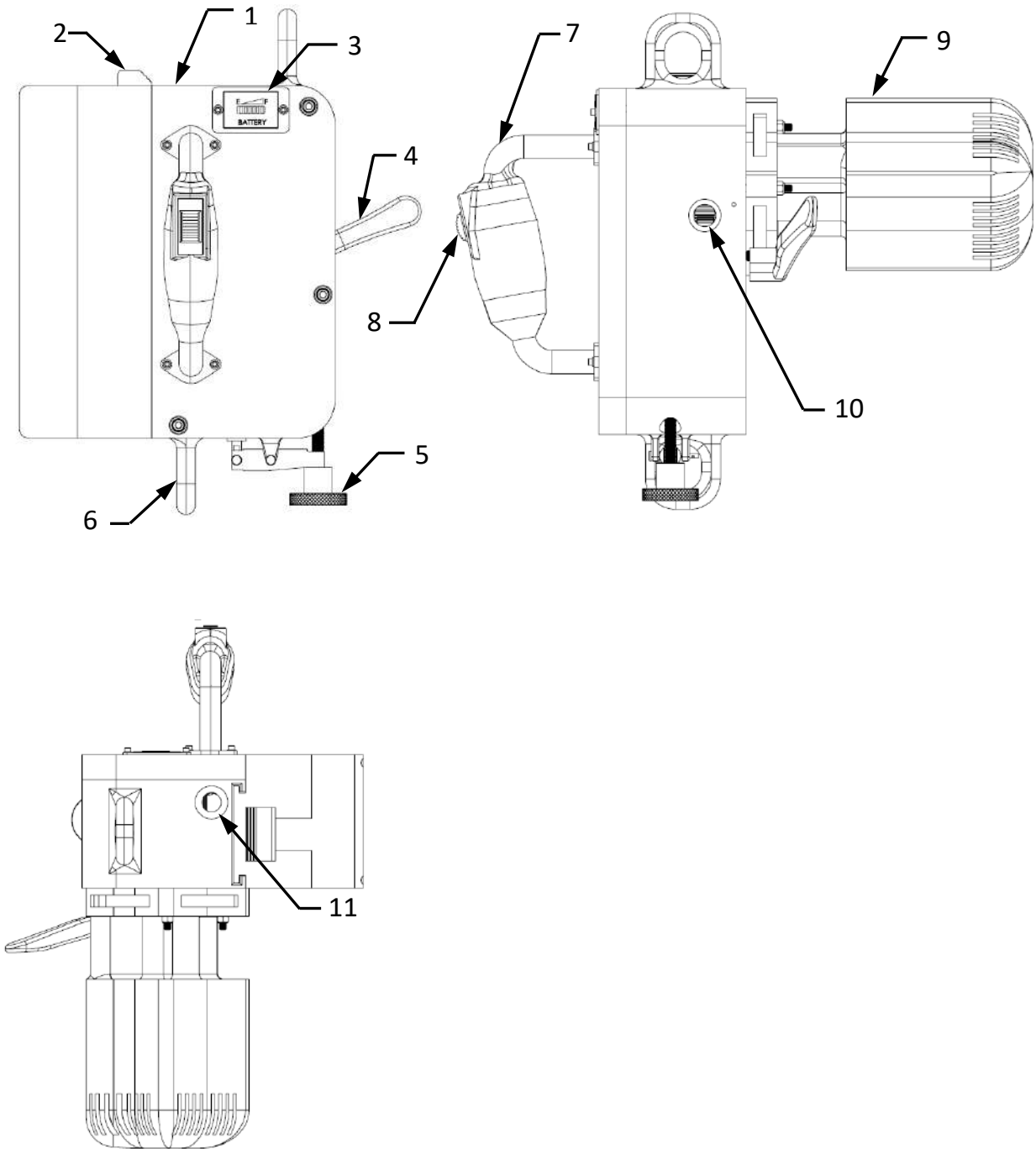

Ronin Lift Personal Ascender

- 1 – Ronin Lift Personal Ascender
- 2 – Lithium Ion Rechargeable Battery
- 3 – Battery Indicator
- 4 – Brake/Descend Handle
- 5 – Tensioner Knob
- 6 – Carabineer Clip Attachment Point
- 7 – Handle
- 8 – Thumbwheel
- 9 – Motor/Gearbox
- 10 – Rope Exit Hole
- 11 – Rope Inlet Hole

Ronin Lift Specifications

Motor	28 VDC nominal 100 amps (1 min burst) 275° F (135° C) max operating Temp 4500 rpm 5 N-m continuous torque
Gearbox	32:1 reduction
Speed Controller	Pulse Width Modulation (PWM) 120 amps max 33 VDC Max
Thumbwheel	.381k ohm 60° rotation
Brake	Manual Operations Via Brake Handle
Rope Diameters	Static Rope 10 mm to 12 mm
Max Rated Power	2,800 watts
Mass	Approximately 24 lbs.
Speed	Variable at Approximately 0.50 – 1.7 ft/sec (0.15 - 0.53m/sec)
Operating Temp	-4° F - 100° F (-20° C - 38° C)
Sound Level	83.1 dBa
Vibration Level	6.9 m/s ²
Capacity	400 lbs. (1.78 kN) Max load or 1 Person Max
Operational Humidity	0 – 85 %
Operating Barometric Pressure	29.9 in. Hg – 7.04 in. Hg (101 kPa – 23.8 kPa)
Storage Temperature	-4° F - 113° F (-20° C - 45° C) Less than 1 month -4° F - 95° F (-20° C - 35° C) Less than 6 months
Storage Humidity	≤ 80% Less than 1 month ≤ 70% Less than 6 months

Battery

Type	Lithium-Ion
Voltage	28.8 VDC Nominal
Amperage	90 amps (1 min burst)
Battery Capacity	6 Ah
Operating Temperature	-4° F - 100° F (-20° C - 38° C)
Mass	Approximately 6.5 lbs. (3Kg)
Battery Life	Approximately 300 Charges
Charge Time	Approximately 2.5 hrs.
Charging Temp	109° F (43° C) Maximum
Storage Temperature	-4° F - 113° F (-20° C - 45° C) Less than 1 month -4° F - 95° F (-20° C - 35° C) Less than 6 months
Storage Humidity	≤ 80% Less than 1 month ≤ 70% Less than 6 months

Power Supply

Type	Lithium-Ion Battery Charger
Input Charging Voltage	110 VAC – 240 VAC
Input Charging Amperage	5 amps max
Operating Temperature	32° F - 95° F (0° C - 35° C)
Operating Humidity	5% - 90%
Charge Time	Approximately 2.5 hrs.
Charging Temp	95° F (35° C) Maximum
Storage Temperature	-4° F - 185° F (-20° C - 85° C)
Storage Humidity	5% - 90%

Rope

Specification	EN 1891 and EN 564 approved rope
Rope Size	10.0 mm – 11.5 mm with less than 2.0% elongation
Rope Size	11.6 mm – 12.0 mm with less than 3.3% elongation
Rope Type	Static Line with Aramid or Kernmantle Sheath
Rope Sheath	32 Strand or Greater
Sheath Slippage	Very Low
Rope Stiffness	Stiff

Box Contents

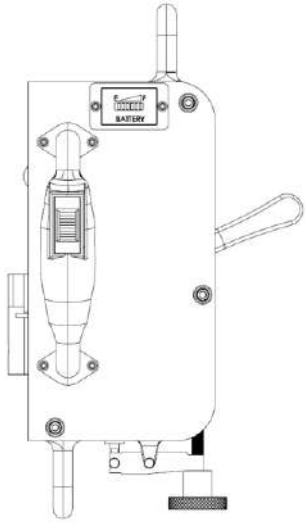

1

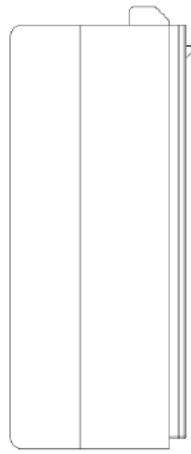

2

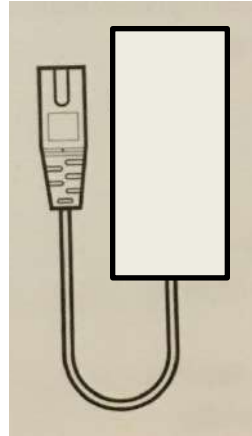

3

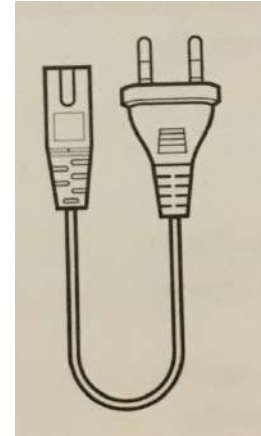

4

1: Ronin Lift Personal Ascender

2: Lithium-Ion Rechargeable Battery

3: AC Power Supply

4: AC Power Cord

Ronin Lift Device Labels

- 1) Warning Label instructions: User must read the entire instruction manual and have a thorough understanding of the device, prior to use. Please contact customer service if you are unsure of anything prior to use.

WARNING! READ
INSTRUCTIONS.
ALWAYS USE A
SECONDARY ROPE
GRAB SYSTEM

- 2) The Ronin Lift label provides device information, part number, serial number, year of manufacture, device limits and capabilities, certifications acquired, and yearly maintenance intervals performed for the 5-year life of the Ronin Lift Personal Ascender.

IRONIN
 600 S. JEFFERSON ST SUITE D
 PLACENTIA CA 92870 USA
 P/N 2805-11
 S/N 3XXX-R
 YEAR OF MFG.
 INSPECTION INTERVALS

	DUE	COMPLETED
1ST INSPECTION	<input type="text"/>	<input type="text"/>
2ND INSPECTION	<input type="text"/>	<input type="text"/>
3RD INSPECTION	<input type="text"/>	<input type="text"/>
4TH INSPECTION	<input type="text"/>	<input type="text"/>
RETIREMENT DATE	<input type="text"/>	<input type="text"/>

DISCHARGE: 33 VDC 90 AMP MAX
 DEVICE WEIGHT: 12.0 kg MAX
 1 PERSON MAX POWER: 4.43 HP
 CAPACITY: .22 - 181 kg MAX (400 lbs.)
 EN ISO 12100:2010 & EN60204-1:2018
 WARNING! READ INSTRUCTIONS BEFORE USE
 PATENT PENDING 15/678,998

- 3) Ronin Lift can only be serviced or repaired by an approved certified repair center or by sending the device back to the manufacturer. The maintenance or repair can be scheduled by calling and obtaining a Return Material Authorization (RMA). Do not open the Ronin Lift or warranty will be voided. The “Do Not Open” label is a tear away one-use label for anti-tampering.

DO NOT OPEN! ONLY APPROVED REPAIR STATION CAN OPEN AND SERVICE DEVICE.

- 4) Max load label is the maximum permitted load on the battery carabineer attachment point. The carabineer Attachment point on the battery is not load bearing, maximum permitted load is 53.4 N (12 lbs. or 5.4 Kg).

MAX LOAD
53.4 N

MAX BATTERY
CLIP LOAD
5.5 kg (12 lbs.)

- 5) The tension label describes which direction to turn the red tensioner knob to apply more (Left Turn) or less tension (Right Turn) to the rope. More tension (Left Turn) increases the grip on the rope to reduce rope slippage with heavier loads. Turning it to the Left (Counterclockwise) direction increases grip on the rope. Turning it fully to the Right (Clockwise) direction allows rope to be loaded in the device.



TENSION KNOB
TURN KNOB RIGHT LOAD ROPE
TURN KNOB LEFT ASCEND
"READ INSTRUCTIONS FOR USE"

- 6) The brake label provides instructions on which direction to operate the brake handle for applying the brake or releasing the brake. The brake is always in the “On” position. To release the brake, you must physically pull down on the handle and hold it open to descend. Once you release the brake, then it will



automatically spring back to the on position. The brake is an On / Off switch and cannot be feathered. To control descent speed and ultimately come to a stop, it is recommended to tend the tailing line of the rope in your right hand, while holding the brake open with your left hand. Simply squeezing the rope with your right hand will slow you down or bring you to a stop.



Charging the battery

The battery takes approx. 2.5 hrs. to charge.

The charger LED codes are the following:

-  Standby (Solid Green with no battery plugged in)
-  Charging (Solid Red when battery is charging)
-  Fully Charged (Solid Green with battery plugged in)

Battery Warnings

- To charge the battery, you must only use the included charger.
- Do not charge the battery, while connected to the Ronin.
- Only use included AC power cord.
- Do not over-discharge the Lithium-Ion battery.
- Remove the battery from the device when storing the unit.
- Disconnect a depleted battery, do not leave a dead battery on the device
- If at any time the Lithium-Ion battery begins to balloon or swell, discontinue charging or discharging immediately.
- Always terminate all processes if the battery/charger malfunctions.
- Do not over charge the battery.
- Store the Lithium-Ion battery at room temperature in a dry area for best results.
- Allow the Lithium-Ion Battery to cool to ambient/room temperature before recharging.
- Never charge the Lithium-Ion battery unattended at any time.
- Never charge the Lithium-Ion battery connected to the Ronin Lift.
- Never Charge the battery above 109 ° F (43 ° C).
- After battery is discharged from use allow 30 minutes rest prior to recharging.

Rope Requirements

- Only use static line rope with aramid or kernmantle sheath in your Ronin Lift. No semi Static ropes.
- The only approved rope sizes for use with the Ronin Lift is Static Rope, range of 10 mm diameter to 12 mm diameter sizes.
- Static rope sizes between 10 mm and 11.5 mm need to have an aramid or kernmantle sheath with low elongation (recommended under 2% elongation). Outer sheath should consist of 32 strands or higher.
- Rope diameter 11.5 mm to 12 mm can be used with larger elongation factors (recommended under 3.3% elongation). Outer sheath must consist of 32 strands or higher. Lower strand counts will result in increased rope wear.
- The diameter of the rope should not shrink below 10 mm when weight is applied to the device. (This can cause the rope to slowly slip when brake is applied)
- Both ends of the rope need to have good clean burnt end where the inner core is no longer exposed or visible. All tape or shrink wrap should be removed from the rope. (see rope burning video <https://www.youtube.com/watch?v=dg79vK0CY5I>)
- The rope should have low sheath slippage and the outer sheath should not balloon or swell.

Rope Warnings

- Only use static line ropes with aramid or kernmantle sheath with Ronin Lift. No Semi Static ropes.
- Use only ropes that are 32 strand or higher.
- Remove any tape or markers from the ends of the rope, before inserting into the Ronin Lift.
- Do not use Dynamic rope.
- Inspect rope prior to use, during use and after use for rope integrity
- Never use damaged or worn rope
- Only use EN 1891 and EN 564 approved rope

Recommended Ropes

Marlow

- Ronin HP Rope (11.5mm)
- Protec 500 (11.0mm)

Teufelberger

- KM III Max (11.0mm)
- Xstatic (11.7mm)

Battery Installation and Motor Initiation

Warning: If battery is to be switched out mid-line, then a lanyard shall be attached to the battery carabineer attachment point and another point either on person or device. This ensures if the battery were to fall, then it will be retained by the lanyard. This is a safety precaution to ensure a battery does not accidentally fall and/or injure person(s) below.

1. Slide the battery down the side of the Ronin Lift, matching the slots in the Ronin Lift with the tangs on the battery.

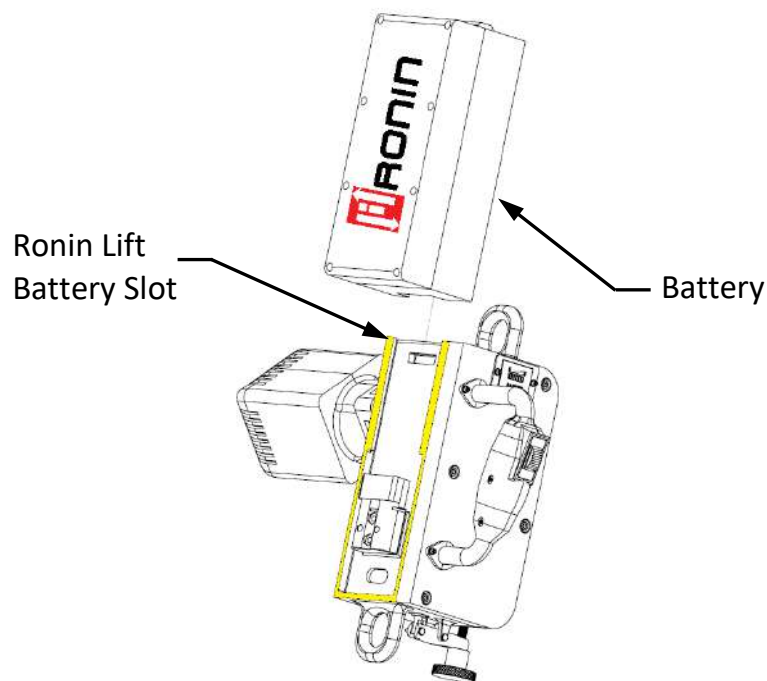

2. Drive the battery down with enough force to mate the connectors.

Note: The connectors are impact resistant, due to tolerance stack some batteries may take more force to connect than others.

3. The battery connection will start up the motor arming sequence. You will hear the controller beep 5 times. After the initial 3 beeps will follow an additional 2 beeps. The final two beeps indicate the motor is armed and the Ronin Lift is ready for use.
4. The battery indicator will also go through a lighting sequence. It will circulate from empty (**red** color tick mark left most side) to full (**green** color tick mark right most side), then display the batteries current charge state.

Loading Rope

1. Fully rotate the red tensioner knob in the clockwise (Right) direction, until the rocker arm bottoms out on the ascenders housing. This will pull down the tensioner and create space to allow the rope to feed into the system. Make sure the red knob is turned fully clockwise (Right), until it cannot be turned any more.

Note: Turn the tensioner knob clockwise (Right) until it cannot turn anymore. The knob will start getting tight and this is due to the spring, continue to screw the knob down, until the rocker arm bottoms out on the main housing.

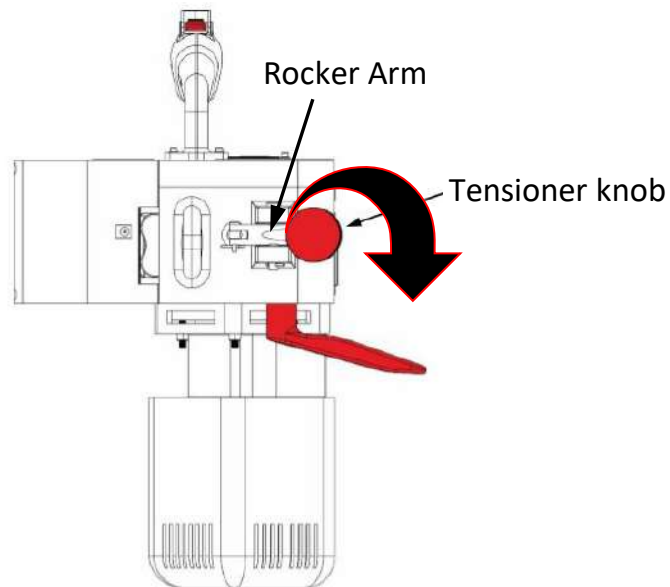

Note: Remove any tape or markers from the ends of the rope, before inserting into the Ronin Lift. Make sure your ends are burnt and No inner core is exposed.

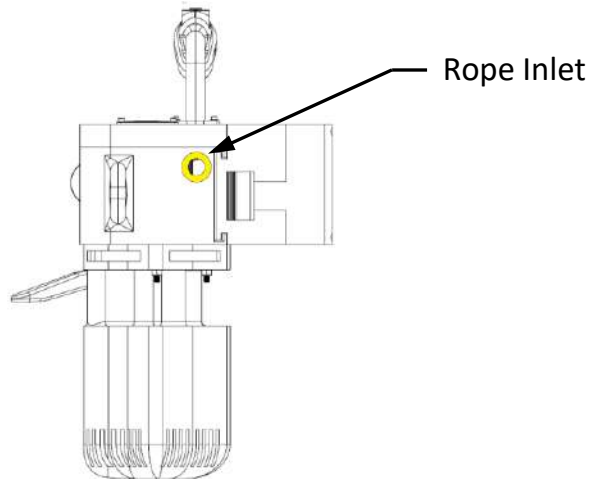

2. Insert Static Line Rope (10 mm to 12 mm diameter) through the rope inlet hole, until it stops. Start pushing rope into the inlet hole and TAP the thumbwheel, while pushing. Continue to push and TAP the thumbwheel, until approx. 8 inches (20 cm) of rope has fed into the system. **Note: You only need to TAP the thumbwheel for this operation. Do not hold the thumbwheel down or this can cause damage to the rope or system.**
3. Now turn the red tensioner knob back to the left (Counterclockwise) to the neutral position (The neutral position is where the knob feels very loose in tension and the rocker arm is floating in between the two flanges on the red tensioner knob). Now pull the brake open slightly and TAP the thumbwheel, until the rope comes out of the exit hole (Note: For units with reverse function do not pull brake fully open or unit will switch into reverse). If the rope does not move or moves very slowly, then you can turn the red tensioner knob 1-2 additional turns in the left (Counterclockwise) direction and repeat the step.

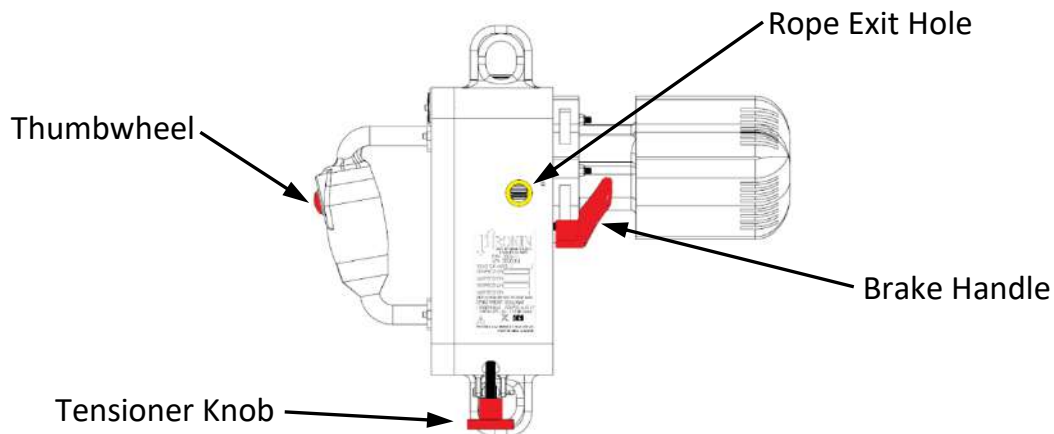

4. Before Ascending turn the red tensioner knob to the left (counterclockwise), until it starts getting tight. The system is now ready to be used.

Operating Ronin Lift

Caution: Ensure you have all safety equipment on and properly secured, prior to using Ronin Lift. Misuse or improperly secured equipment could result in serious injury or death. Never use the Ronin Lift Personal without a secondary rope grab system.

1. Below is an example of a rope grab system, this is one example. There are many different secondary safety line systems that can be used.



2. Be sure to use a load bearing carabineer clip that complies with ANSI / CE standards. Connect the Ronin Lift Personal Ascender to your harness with a carabineer, using the lower Ronin housing attachment point.

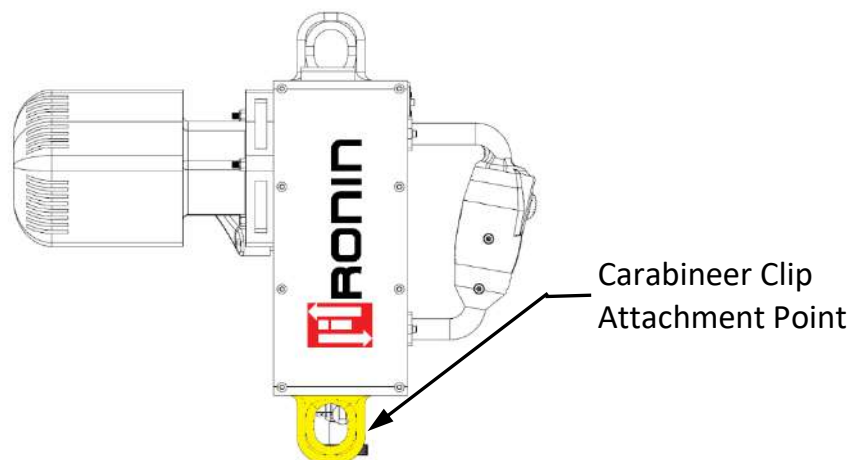

3. Prior to ascent, turn the Red Tensioner knob to the left (counterclockwise), until it starts to get tight. The more weight you lift, then the tighter you need to turn, in the left (counterclockwise) direction. **(Note: The Ronin is a non-slip system, so if the Ronin is slipping, while ascending, then STOP. Apply more tension by turning the Red Tensioner knob counterclockwise, until Ronin is no longer slipping under power).** For best rope wear, the tensioner should be set for the weight you are lifting. Do not just turn the tensioner as tight as you can, or this will result in increased rope wear.
4. Grip the handle in your hand and gently roll the thumbwheel down slowly, to actuate the motor & remove any slack in the line. **Note: If your Ronin is equipped with a deadman trigger, then you will need to pull the deadman trigger first before the thumbwheel can activate the motor.**
5. Once the slack has been removed you can rotate the thumbwheel down slowly to start ascending. The thumbwheel switch is a variable speed thumbwheel capable of providing ascent speeds of 0.5 – 1.7 ft/sec (0.15 - 0.53m/sec). The further you roll down the thumbwheel the faster the ascent will be. **(Note: The brake is always engaged automatically, while ascending. Once you stop your ascent the Ronin will automatically brake in that spot).**

Warning: Prior to ascent double check all equipment for integrity, rope, Ronin Lift, Harness, Safety line connected and functioning, Helmet secured, etc.

Warning: Before operation, the user shall ensure there is no risk of objects falling on the lift, operator, or surrounding person(s) below.

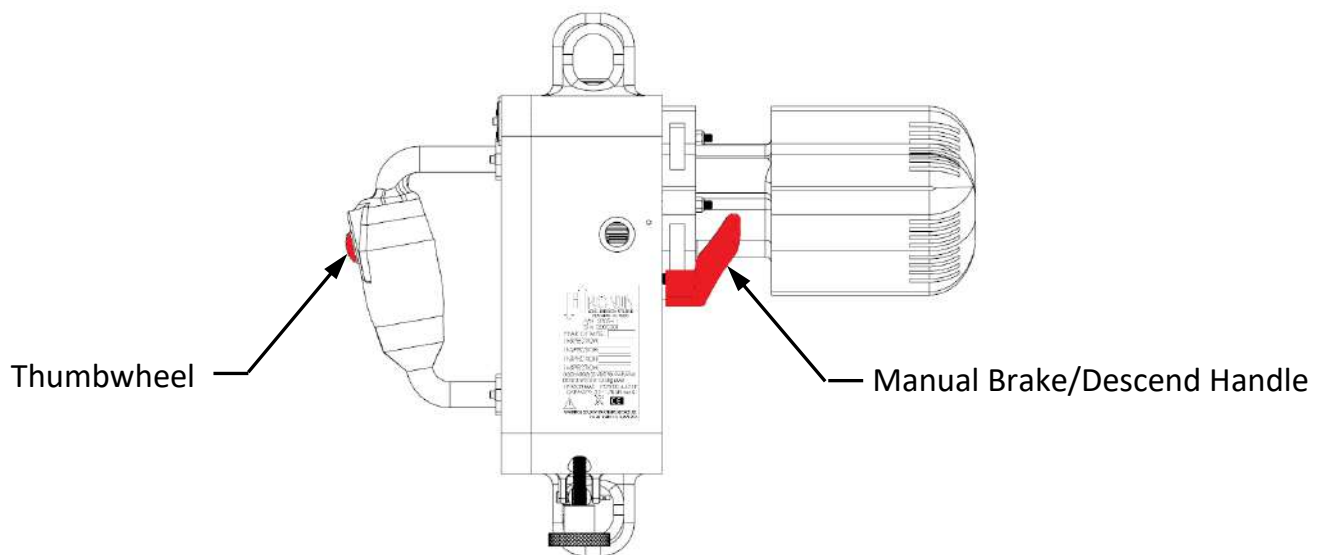

6. When ready to stop ascending release the thumbwheel switch. (**Note: The brake is always engaged, while ascending. Once you stop your ascent the Ronin will automatically brake in that spot.**)

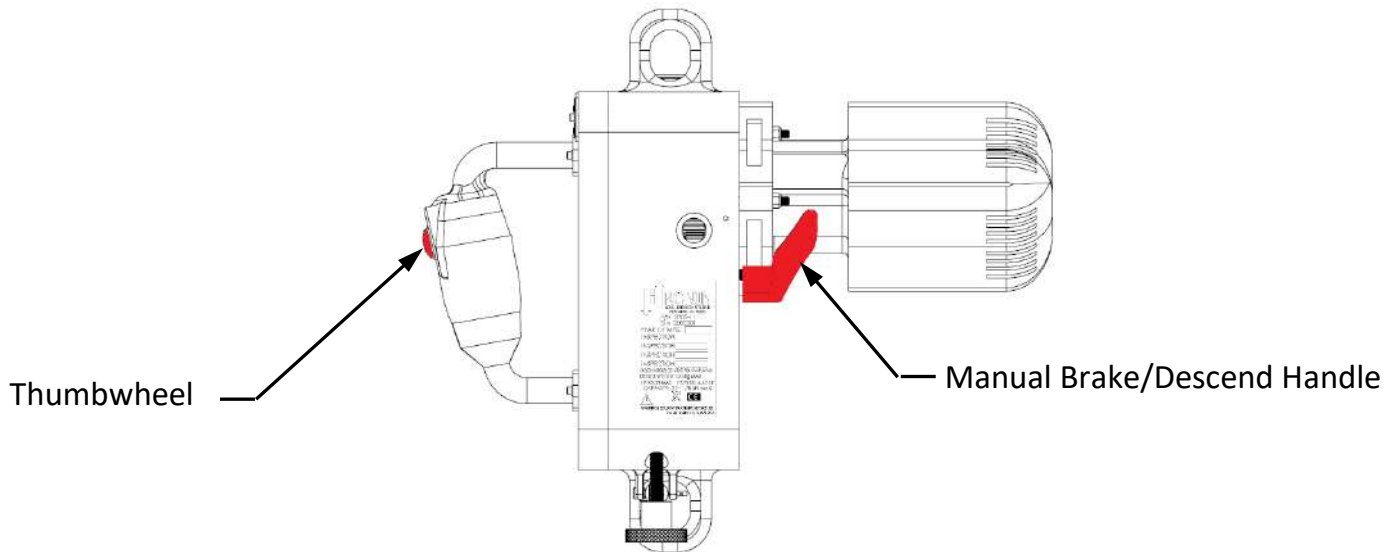

7. When descending its best practice to TAP the thumbwheel and then simultaneously pull the brake handle down. This will help to preserve your rope. (Note: If you pull the brake handle open and do not descend or descend very slowly, then turn the Red Tensioner Knob to the Right (clockwise) 1-2 turns, until you start to descend. This is due to the tensioner knob being too tight for the weight you are lifting.)

Caution: For Ronin Lifts with reverse function, do not pull down on the thumbwheel, with the brake fully open. This will activate reverse function, which is not recommended for descending.

8. When descending you can control your speed and braking best by tending the rope tailing line with your right hand. While holding the brake handle fully down, if you pull slightly on the rope, while descending, then you can control speed. If you pull tightly, then the unit will stop, and you can release the brake to stay in place. This is the best practice for preserving rope. (Note: You can always just release the brake at any speed to stop)

Note: The Ronin's brake is an On / Off Switch and cannot be feathered. It acts similarly to any backup device. Follow the steps above to control descent speed and increase rope longevity.

WARNING: Do not turn the red tensioner knob in past the neutral position, when descending. The neutral position is when the level arm is floating in between the two flanges on the red tensioner knob. Knob tension will be loose and easy to turn in this position.

Note: A 2:1 or 3:1 pulley system can be used with the Ronin Lift. This reduces the speed of the device but allows for max loads of 800lbs (363Kg) or 1200lbs (544Kg).

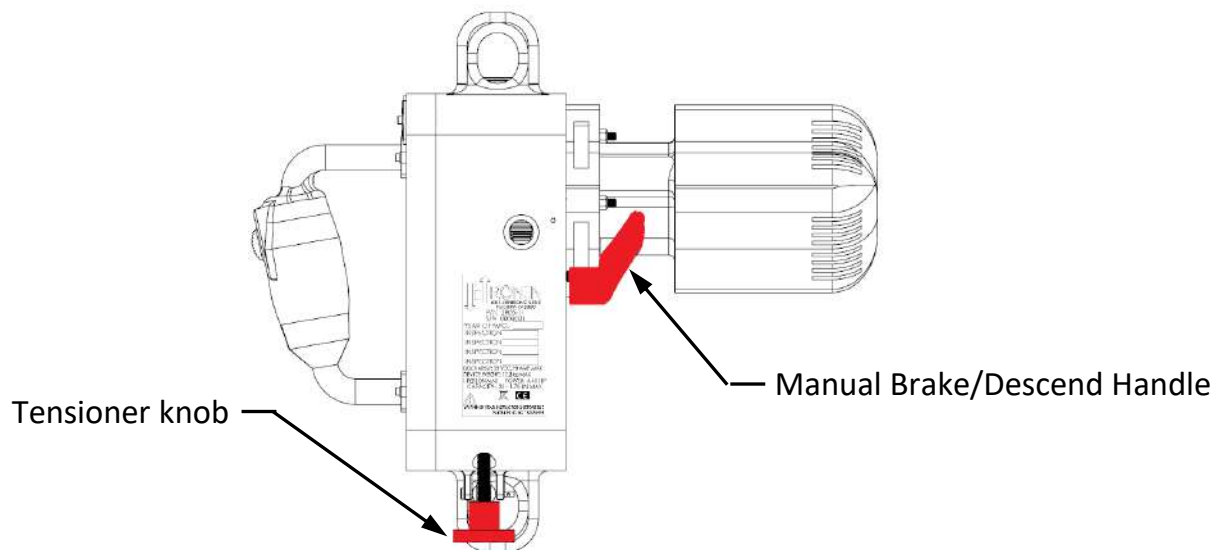

9. Once you are safely on the ground and sufficient slack has been taken out of the rope, then release the brake and you may now unclip from Ronin Lift.

Ronin Lift Duty Cycle

Ronin Lift requires a duty cycle to ensure the device housing does not exceed temperatures defined by CE certification requirements as unsafe. The max CE permitted temperature is 129 °F (54 °C) in which skin can touch metal and not be burned. To meet this requirement please do not exceed the duty cycle described below:

- The Ronin Lift can ascend 200 ft. of rope continuously in 100 °F (38 °C) temperature with max load of 400 lbs. (181Kg).
- Followed by a 30 min. rest and an additional 50 ft. (15m) can be ascended.
- The 30 min. rest and additional 50 ft. (15m) of ascent can be performed 3 additional times after the initial 200 ft. (61m) of ascent.

Then unit needs to cool down back to 100 °F (38 °C) temperature. Then the duty cycle may be performed one additional time per day.

Battery Overcurrent Protection

- Overload occurs when excessive load is trying to be lifted
- If overload condition occurs power will be cut from the system
- To reset system in an overload event, disconnect the battery, wait 10 seconds, and reconnect battery
- Additional weight may need to be removed to prevent further overload events
- In the event overload condition occurs and battery removal is not achievable, release the brake to descend to ground. Then follow the above reset procedure.

Inspection and Maintenance

During the Ronin Lifts life cycle, periodic inspection and maintenance is required. Some parts will experience wear and will need to be replaced. See table below for periodic inspection, maintenance check and parts replacement intervals.

Part Number	Description	Inspection Interval	Inspection	Maintenance Interval	Maintenance	Replacement Interval
101504	Thumbwheel & optional Deadman Trigger	Daily Prior to Use	With battery connected rotate thumbwheel downward slowly and verify motor increases in speed. Then rotate thumbwheel slowly back to neutral position and verify thumbwheel decreases motor speed to off. If your device has the Deadman Trigger option, then verify the trigger springs back to the start position, when released. Make sure the thumbwheel does not activate the motor without the Trigger being Squeezed.	None	None	Annual Inspected
151023	Motor	Daily Prior to Use	With battery connected rotate thumbwheel downward slowly and verify motor increases in speed. Then rotate thumbwheel slowly back to the off position and verify thumbwheel decrease motor speed to off in the neutral position. Ensure there is no debris blocking the air vents in the motor cover and the motor is free from debris inside. If debris is found blow out using air.	None	None	Annual Inspected
770518	Tensioner Knob	Daily Prior to Use	Visually inspect tensioner knob threads are in good working condition and lubricated with Teflon grease	Monthly	Apply Teflon based grease	Annual Inspected
520435	Tensioner Assembly	N/A	Verify tensioner assembly moves up and down smoothly with operation of the tension knob	None	None	1 year
112483	Battery Indicator	Daily Prior to Use	Verify when battery is connected indicator flashes through the indicator lights and then displays current battery charge	None	None	Annual Inspected
110230	Cam Cinch Assembly	Daily Prior to Use	Look into the Ronin Lift Exit hole and visually inspect that Cam Cinch teeth are not clogged with any debris and are not worn	None	None	1 year

82610	Drive Shaft Assembly	N/A	Will be performed at authorized repair facility	None	None	Annual Inspected
508822	Battery	Daily Prior to Use	Verify battery is not damaged, leaking, or swollen	None	None	Approx. 300 Charges

Inspection and Log Sheet

When returning your Ronin Lift to have the yearly required inspection and part replacement performed, please return to Ronin Revolution Corp or your local certified Ronin Repair Center. If you are returning your Ronin Lift to Ronin Revolution Corp., then follow the steps below...

1. Request an RMA (Return Material Authorization) form from Ronin Customer Support by visiting www.ronin.inc and clicking on the Service tab. Complete the RMA form and submit or contact us at link at www.info@ronin.inc or www.changeyourelevation.com
2. Package products along with a copy of the RMA form.
3. Make sure to package your return securely, if you are not shipping back in the original packaging or the Ronin hard case.

Note: Please do not hand deliver your product to the Ronin facility, even if you are local. This facility is not set up to receive visitors.

Annual Service Exceptions

For users that have not used their Ronin's or have had very little use, see annual service guidelines below.

- If you have a Ronin that is a backup unit and has not been used for the 12-month period, then there is no need to send it in for annual Service.
- Any Ronin that has ascended 2000ft (610m) or less of rope in a 12-month period, does not have to be returned for annual service. Use the table below to track your usage.

Tracking Your Ascending						
Part Number: 2805-11				Product: Ronin Lift		
Serial Number:				First Date of Use:		
	Date	Number of Times Ascending		Height of Lift (ft/m)		Total Length of rope ascended
1			X		=	
2			X		=	
3			X		=	
4			X		=	
5			X		=	
6			X		=	
7			X		=	
8			X		=	
9			X		=	
10			X		=	
You Ronin's service life is complete 12 months after your 4th Annual Service						

Inspection Interval 1 Date:

Work Performed:

Inspection Interval 2 Date:

Work Performed:

Inspection Interval 3 Date:

Work Performed:

Inspection Interval 4 Date:

Work Performed:

End of life

After 5 years of service, the Ronin's service life is complete. Service life is based on time, which is defined by how many annual services the lift has received. A Ronin's service life is complete 12 months after the 4th annual service. Your annual services will be marked on the Ronin's id Plate, by the certified repair center that performed the service. If the Ronin does not need to be returned, because it falls under one of the Annual Service Exceptions, then the life of a Ronin can be extended up to 10 years. The service life of a Ronin cannot exceed 10 years under any circumstances.

The Ronin Lift is made of many materials that may be recycled. The battery contains lithium ion materials and the lift contains aluminum. The speed controller contains solder and electrical components. Ronin products can be recycled for free in the United States and Canada by dropping the product off at any number nationwide recycling locations.

Ronin Warranty

Ronin products and accessories are guaranteed against manufacturing defects for 90 days from the original date of purchase or the minimum legally mandatory country requirement, from the original date of purchase. In the event of such defects, Ronin will repair or replace the defective part(s) or product(s) with comparable parts or products at Ronin's sole discretion. Damage resulting from use, water intrusion, physical damage, or normal wear and tear is not covered by this or any warranty. Ronin assumes no liability for any accident, injury, death, loss, or other claim related to or resulting from the use or misuse of any products. In no event shall Ronin be liable for incidental or consequential damages relating to or resulting from the use of this product or any of its parts. This product is not warrantied against user repairs and user repairs will void the warranty. Breaking the seal on the Ronin cover also results in immediate loss of warranty. Returns or replacements of parts and/or products may be subject to shipping, handling, replacement, and/or restocking fees.

If you have purchased your product(s) from an authorized Ronin distributor, then please contact the distributor for warranty claims.