



The Ultimate in Fall Protection

ANSI/ASSE Z359.11-2014
 Please read this User Manual carefully before using the associated products.

USER INSTRUCTION MANUAL



Figure 1 – ExoFit Strata™ Full Body Harness Models

Models	SM	MED	LG	XL	2XL	Tri-Lock	Duo-Lock	Tongue Buckle	Belt	Hip Pad	①	②	③	④	⑤
											Suspension Seat	Dorsal	Sternal	Shoulder	Hip
											Size		Buckles		Belt & Pad
1112535 - 1112539	1112540 - 1112544	1112545 - 1112549	1112535	✓					✓	✓		✓			✓
			1112536		✓				✓	✓		✓			✓
			1112537			✓			✓	✓		✓			✓
			1112538				✓		✓	✓		✓			✓
			1112539			✓	✓		✓	✓		✓			✓
			1112540	✓					✓	✓		✓	✓		✓
			1112541		✓				✓	✓		✓	✓		✓
			1112542			✓			✓	✓		✓	✓		✓
			1112543				✓		✓	✓		✓	✓		✓
			1112544			✓	✓		✓	✓		✓	✓		✓
			1112545	✓					✓	✓		✓	✓	✓	✓
			1112546		✓				✓	✓		✓	✓	✓	✓
			1112547			✓			✓	✓		✓	✓	✓	✓
			1112548				✓		✓	✓		✓	✓	✓	✓
			1112549			✓	✓		✓	✓		✓	✓	✓	✓
			1112550	✓				✓	✓	✓		✓	✓	✓	✓
			1112551		✓			✓	✓	✓		✓	✓	✓	✓
			1112552			✓		✓	✓	✓		✓	✓	✓	✓
			1112553				✓	✓	✓	✓		✓	✓	✓	✓
			1112554			✓		✓	✓	✓		✓	✓	✓	✓
			1112555	✓				✓	✓	✓		✓	✓	✓	✓
			1112556		✓			✓	✓	✓		✓	✓	✓	✓
			1112557			✓		✓	✓	✓		✓	✓	✓	✓
			1112558				✓	✓	✓	✓		✓	✓	✓	✓
			1112559			✓		✓	✓	✓		✓	✓	✓	✓
			1112560	✓				✓	✓	✓		✓	✓	✓	✓
			1112561		✓			✓	✓	✓		✓	✓	✓	✓
			1112562			✓		✓	✓	✓		✓	✓	✓	✓
			1112563				✓	✓	✓	✓		✓	✓	✓	✓
			1112564			✓		✓	✓	✓		✓	✓	✓	✓
			1112565	✓				✓	✓	✓		✓	✓	✓	✓
			1112566		✓			✓	✓	✓		✓	✓	✓	✓
			1112567			✓		✓	✓	✓		✓	✓	✓	✓
			1112568				✓	✓	✓	✓		✓	✓	✓	✓
			1112569			✓		✓	✓	✓		✓	✓	✓	✓
			1112570	✓				✓	✓	✓		✓	✓	✓	✓
			1112571			✓		✓	✓	✓		✓	✓	✓	✓
			1112572				✓	✓	✓	✓		✓	✓	✓	✓
			1112573			✓		✓	✓	✓		✓	✓	✓	✓
			1112574				✓	✓	✓	✓		✓	✓	✓	✓
			1112575	✓				✓	✓	✓		✓	✓	✓	✓
			1112576		✓			✓	✓	✓		✓	✓	✓	✓
			1112577			✓		✓	✓	✓		✓	✓	✓	✓
			1112578				✓	✓	✓	✓		✓	✓	✓	✓
			1112579			✓	✓	✓	✓	✓		✓	✓	✓	✓

Figure 1 – ExoFit Strata™ Full Body Harness Models

		SM	MED	LG	XL	2XL	Tri-Lock	Duo-Lock	Tongue Buckle	Belt	Hip Pad	① Suspension Seat	② Dorsal	③ Sternal	④ Shoulder	⑤ Hip	
Models	Size	Buckles					Belt & Pad		Attachment Elements								
1112580 - 1112584	1112585 - 1112589	✓					✓		✓	✓	✓	✓	✓	✓	✓	✓	✓
			✓				✓		✓	✓	✓	✓	✓	✓	✓	✓	✓
				✓			✓		✓	✓	✓	✓	✓	✓	✓	✓	✓
					✓		✓		✓	✓	✓	✓	✓	✓	✓	✓	✓
						✓	✓		✓	✓	✓	✓	✓	✓	✓	✓	✓
		✓					✓		✓	✓	✓	✓	✓	✓	✓	✓	✓
			✓				✓		✓	✓	✓	✓	✓	✓	✓	✓	✓
				✓			✓		✓	✓	✓	✓	✓	✓	✓	✓	✓
						✓	✓		✓	✓	✓	✓	✓	✓	✓	✓	✓

Figure 2 – ExoFit Strata™ Harness Components

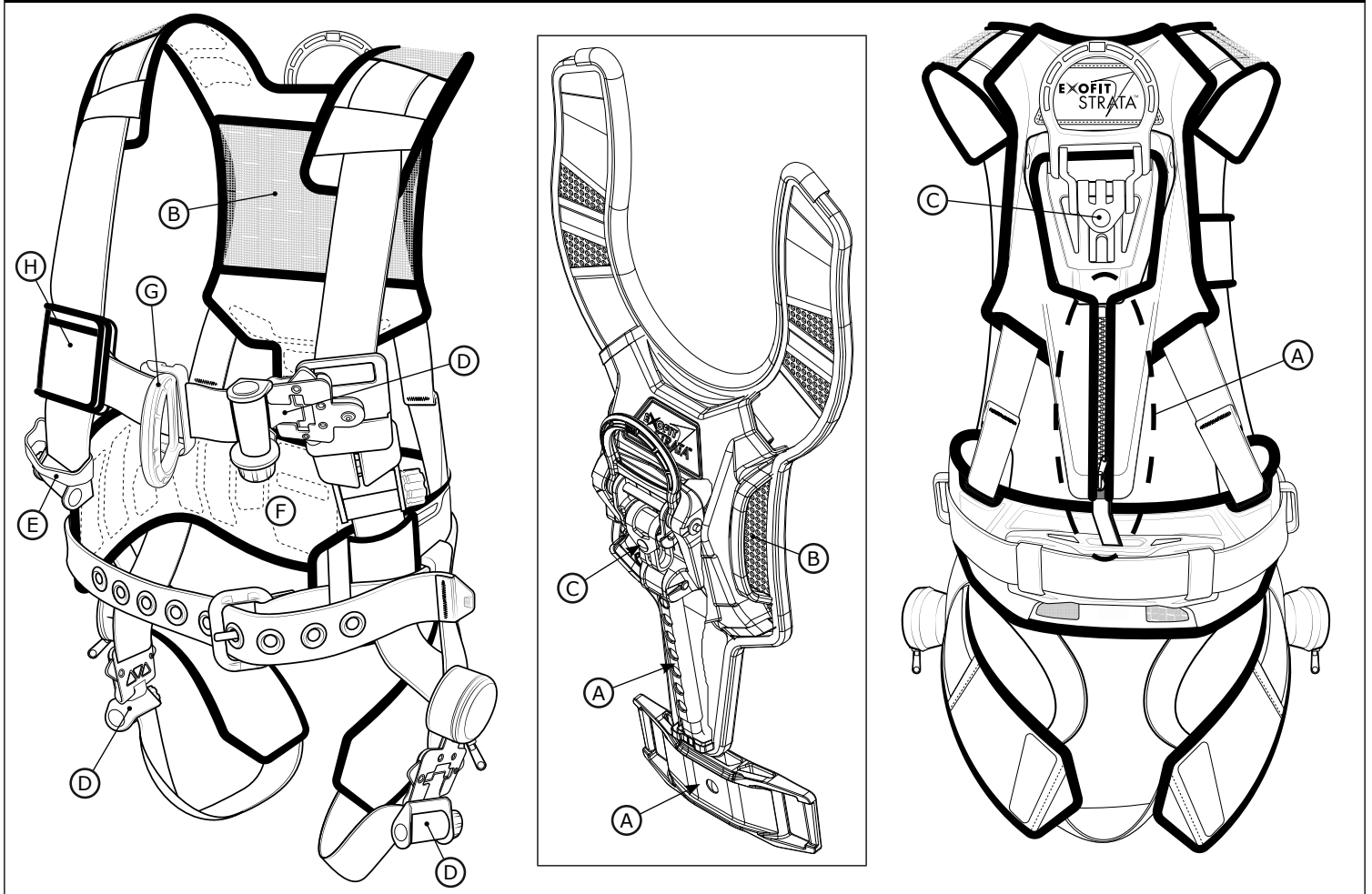

A - LIFTech Weight Distribution System **B** - PolarMesh Back Pad **C** - EZ-Link Personal SRL Adapter **D** - Tri-Lock Revolver™ Buckles
E - Break-Away Auto-Reset Lanyard Keepers **F** - EVA Thermoformed Hip Pad **G** - Store-Away Sternal D-Ring **H** - Personalization Pocket

DANGER: This product is part of a personal fall arrest, restraint, work positioning, personnel riding, climbing, or rescue system. The user must follow the manufacturer's instructions for each component of the system. These instructions must be provided to the user of this equipment. The user must read and understand these instructions before using this equipment. Manufacturer's instructions must be followed for proper use and maintenance of this equipment. If this product is resold outside the original country of destination, the re-seller must provide these instructions in the language of the country in which the product will be used. Alterations or misuse of this product or failure to follow instructions may result in serious injury or death.

IMPORTANT: If you have questions on the use, care, or suitability of this equipment for your application, contact Capital Safety.

IMPORTANT: Before using this equipment, record the product identification information from the ID label in the inspection and maintenance log of this manual.

DESCRIPTION

Figure 1 defines available ExoFit Strata® Full Body Harness models. ExoFit Strata Harnesses include various combinations of the following features on previous DBI-SALA Full Body Harnesses:

- Tech-Lite™ Aluminum D-Rings - Varied Locations: Dorsal, Sternal, Shoulder, Hip, and Suspension Seat
- Duo-Lok™ Quick Connect Buckles
- Tongue Buckle Leg Straps
- Tongue Buckle Body Belt
- Repel Technology Webbing
- Hybrid Comfort Padding
- Lumbar Pad
- Revolver™ Adjusters
- Tongue Buckle Body Belt
- Suspension Trauma Straps

In addition, ExoFit Strata Harness models include the following new innovations (illustrated in Figure 2):

- LIFTech™ Weight Distribution System (A)
- PolarMesh™ Back Pad (B)
- EZ-Link™ Personal SRL Adapter (C)
- Tri-Lock Revolver™ Buckles (D)
- Break-Away Auto-Reset Lanyard Keepers (E)
- EVA Thermoformed Hip Pad (F)
- Store-Away Sternal D-Ring (G)
- Personalization Pocket (H)







SPECIFICATIONS

Performance:	
Maximum Free Fall Distance	6 ft (1.8 m)
Maximum Arresting Force	1,800 lbs (13 kN)
Capacity	ANSI Z359.11 Capacity Range: 130 lbs - 310 lbs (59 kg - 141 kg) OSHA Maximum Capacity: 420 lbs (191 kg)

Materials:	
Webbing	Polyester - 6,000 lbs (27 kN) Tensile Strength Nylon - 7,000 lbs (31 kN) Tensile Strength
Pad Covers	Blend of Nylon and Polyester
Label Cover	Blend of Nylon and Polyester
Thread	Polyester Thread on Polyester Webbing Nylon Thread on Nylon Webbing
D-Rings	Aluminum Alloy - 5,000 lbs (22 kN) Tensile Strength
Duo-Lok Connectors	Aluminum Alloy, Stainless Steel, and Alloy Steel - 4,000 lbs (18 kN) Tensile Strength
Tri-Lok Connectors	Aluminum Alloy, Stainless Steel, and Alloy Steel - 4,000 lbs (18 kN) Tensile Strength
Revolver Adjusters	Aluminum Alloy, Stainless Steel, Alloy Steel, and Nylon - 4,000 lbs (18 kN) Tensile Strength

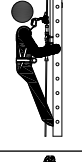
1.0 APPLICATIONS

1.1 PURPOSE: Full Body Harnesses are to be used as components in Personal Fall Protection System designed to prevent a fall or safely arrest a fall. Full Body Harnesses are used in the following applications:

	<p>Fall Arrest: Personal fall arrest systems typically include a Full Body Harness and a connecting subsystem (Energy Absorbing Lanyard, Self-Retracting Device, etc.). Maximum arresting force must not exceed 1,800 lbs (8 kN).</p> <p><i>Attachment Elements:</i> Dorsal (feet first with a 2 ft. maximum free fall when using a Self-Retracting Device or 6 ft. maximum free fall when using an Energy Absorbing Lanyard), Sternal (feet first with a 2 ft. maximum free fall), Frontal (feet first with a 2 ft. maximum free fall).</p>
	<p>Work Positioning: Work positioning systems typically include a Full Body Harness, positioning lanyard, and a back-up personal fall arrest system. For work positioning applications, connect the work positioning subsystem (example: lanyard, Y-lanyard, etc.) to the lower (hip level) side or belt mounted work positioning attachment anchorage elements (D-Rings). Never use these connection points for fall arrest.</p> <p><i>Attachment Elements:</i> Frontal, Hip.</p>
	<p>Climbing: The Full Body Harness is used as a component of a climbing system to prevent the user from falling when climbing a ladder or other climbing structure. Climbing systems typically include a Full Body Harness, vertical cable or rail attached to the structure, and climbing sleeve. For ladder climbing applications, harnesses equipped with a frontal D-Ring in the sternal location may be used for fall arrest on fixed ladder climbing systems.</p> <p><i>Attachment Elements:</i> Sternal</p>
	<p>Rescue: The Full Body Harness is used as a component of a rescue system. Rescue systems are configured depending on the type of rescue. For limited access (confined space) applications, harnesses equipped with D-Rings on the shoulders may be used for entry and egress into confined spaces where worker profile is an issue.</p> <p><i>Attachment Elements:</i> Dorsal, Sternal, Frontal, Shoulder</p>
	<p>Controlled Descent: For controlled descent applications, harnesses equipped with a single sternal level D-Ring, one or two frontal mounted D-Rings, or a pair of connectors originating below the waist (such as a seat sling) may be used for connection to a descent or evacuation system.</p> <p><i>Attachment Elements:</i> Dorsal Sternal, Frontal</p>
	<p>Restraint: The Full Body Harness is used as a component of a restraint system to prevent the user from reaching a fall hazard. Restraint systems typically include a Full Body Harness and a lanyard or restraint line.</p> <p><i>Attachment Elements:</i> Dorsal, Sternal, Frontal, Hip</p>

⚠ CAUTION: Certain application and work conditions require the use of Full Body Harnesses with specific attributes:

- Full body harnesses with Kevlar web should be used when working with tools, materials, or environments of high temperature (foundries, chemical manufacturing, steel fabrication, emergency rescue services, fire services, welders, oil industry, nuclear industry, explosives).
- Harnesses with PVC coated hardware should be used when working in explosive or electrically conductive environments, or where surfaces must be protected from the hardware.
- Harnesses with high visibility webbing should be used when increased visibility of the user is required.

1.2 STANDARDS: Harnesses included in this manual conform to the standard(s) identified on the front cover of this instruction.

1.3 TRAINING: It is the responsibility of the user and the purchaser of this equipment to assure that they are familiar with these instructions, trained in the correct care and use of, and are aware of the operating characteristics, application limits, and the consequences of improper use of this equipment.

⚠ CAUTION: Training must be conducted without exposing the user to a fall hazard. Training should be repeated on a periodic basis.

1.4 LIMITATIONS: Always consider the following application limitations before using this equipment:

- **CAPACITY:** The Full Body Harness is designed for use by persons with a combined weight (clothing, tools, etc.) ranging from 130 lbs (59 kg) to 310 lbs (140 kg). Make sure all of the components in your system are rated to a capacity appropriate to your application.

① NOTE: 310 lbs (140 kg) is the maximum capacity allowed by ANSI/ASSE Z359.11. Capital safety harnesses are factory tested to a maximum capacity of 420 lbs (191 kg).

- **FREE FALL:** Personal fall arrest systems used with this equipment must be rigged to limit the free fall to 6 feet (1.8 m)¹. Restraint systems must be rigged so that no vertical free fall is possible. Work positioning systems must be rigged so that free fall is limited to 2 feet (.6 m) or less. Personnel riding systems must be rigged so that no vertical free fall is possible. Climbing systems must be rigged so that free fall is limited to 18 in. (.46 m) or less. Rescue systems must be rigged so that no vertical free fall is possible. See subsystem manufacturer's instructions for more information.

1 Fall Arrest Free Falls: Free falls greater than 6 ft. (1.8 m) may be permitted when users are secured to the anchorage with a connecting subsystem which limits maximum arresting force to 1,800 lbs (8 kN) and is authorized for such use (i.e., DBI-SALA Force 2™ Lanyards).

- **FALL CLEARANCE:** Figure 3 illustrates the components of a Fall Arrest. There must be sufficient clearance below the user to arrest a fall before the user strikes the ground or other obstruction. Clearance is affected by a number of factors including the following parameters:

Elevation of Anchorage	Free Fall Distance	Worker Height
Connecting Subsystem Length	Deceleration Distance	Attachment Element Movement and Harness Stretch

① **NOTE:** Refer to the instructions included with your Fall Arrest subsystem for specifics regarding Fall Clearance calculation.

- **SWING FALLS:** Swing Falls occur when the anchorage point is not directly above the point where a fall occurs (see Figure 4). The force of striking an object in a swing fall may cause serious injury or death. Minimize swing falls by working as directly below the anchorage point as possible. Do not permit a swing fall if injury could occur. Swing falls will significantly increase the clearance required when a Self-Retracting Device or other variable length connecting subsystem is used.
- **EXTENDED SUSPENSION:** A Full Body Harness is not intended for use in extended suspension applications. If the user is going to be suspended for an extended length of time it is recommended that some form of seat support be used. Capital Safety recommends a seat board, suspension work seat, seat sling, or a boatswain chair. Contact Capital Safety for more information on these items.
- **ENVIRONMENTAL HAZARDS:** Use of this equipment in areas with environmental hazards may require additional precautions to prevent injury to the user or damage to the equipment. Hazards may include, but are not limited to; heat, chemicals, corrosive environments, high voltage power lines, gases, moving machinery, and sharp edges.
- **HARNESSES FOR HIGH TEMPERATURE ENVIRONMENTS:** Harnesses with Kevlar webbing are designed for use in high temperature environments, with limitations: Kevlar webbing begins to char at 800° to 900° Fahrenheit. Kevlar webbing can withstand limited contact exposure to temperatures up to 1,000° F. Polyester webbing loses strength at 300° to 400° F. PVC coating on hardware has a melting point of approximately 350° F.

⚠ **WARNING:** When working with tools, materials, or in high temperature environments, ensure that associated fall protection equipment can withstand high temperatures, or provide protection for those items.

⚠ **WARNING:** Although PVC coated and zinc plated hardware exhibit excellent corrosion resistance in chemical, acidic, alkaline, and atmospheric conditions, frequent inspections may be required. Consult with Capital Safety if you question the use of this equipment in hazardous environments.

Figure 3 – Fall Arrest Components

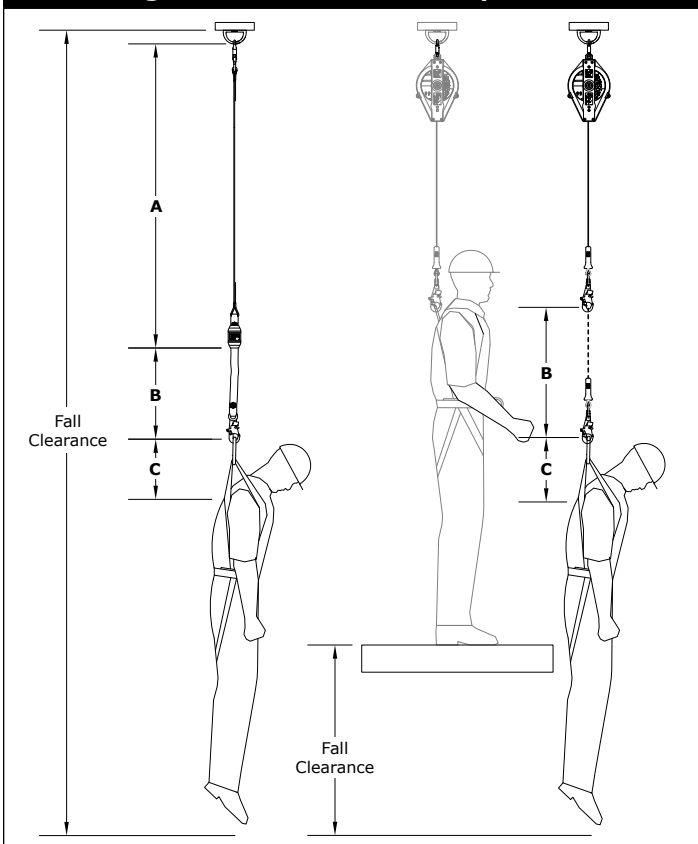
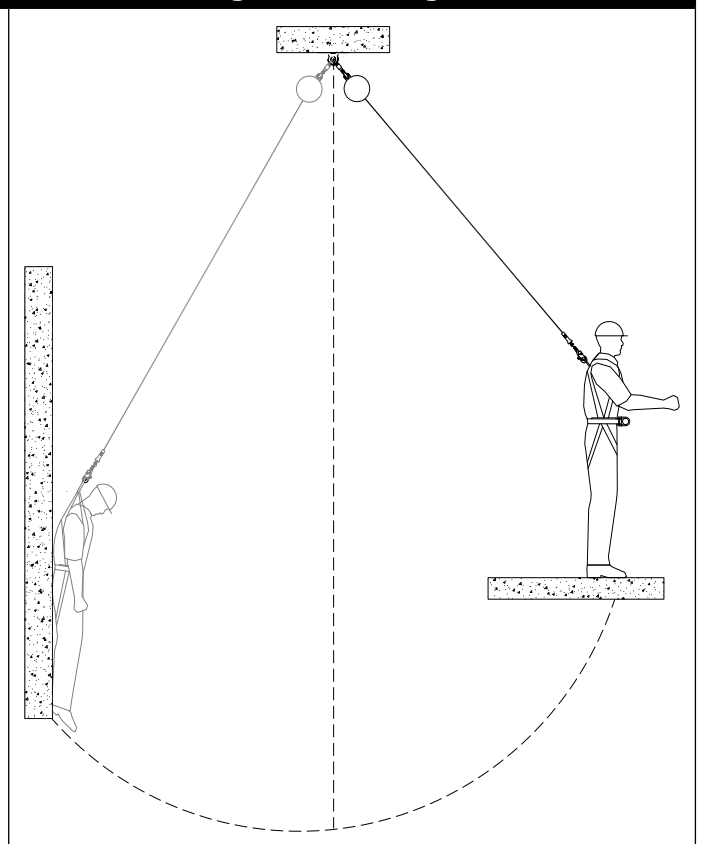

Figure 4 – Swing Fall



- A - Lanyard Length**
- B - Lanyard Deceleration Distance or SRL Maximum Arrest Distance**
- C - Safety Factor = Harness Stretch (H_c) + D-Ring/Connector Length + Settling = 1.5 ft (0.5 m)**

2.0 SYSTEM USE

- 2.1 RESCUE PLAN:** When using this equipment and connecting subsystem(s), the employer must have a rescue plan and the means at hand to implement and communicate that plan to users², authorized persons³, and rescuers⁴.
- 2.2 INSPECTION FREQUENCY:** The Full Body Harness shall be inspected by the user before each use and by a competent person⁵ other than the user at intervals of no more than one year⁶. Inspection procedures are described in the *User Instruction Manual's "Inspection and Maintenance Log"*. Results of each Competent Person inspection should be recorded on copies of the *"Inspection and Maintenance Log"* or tracked with the i-Safe™ system (see *"Inspection"*).
- 2.3 COMPATIBILITY OF COMPONENTS:** Capital Safety equipment is designed for use with Capital Safety approved components and subsystems only. Substitutions or replacements made with non-approved components or subsystems may jeopardize compatibility of equipment and may effect the safety and reliability of the complete system.
- 2.4 COMPATIBILITY OF CONNECTORS:** Connectors are compatible with connecting elements when they have been designed to work together in such a way that their sizes and shapes do not cause their gate mechanisms to inadvertently open regardless of how they become oriented. Contact Capital Safety if you have any questions about compatibility. Connectors (hooks, carabiners, and D-Rings) must be capable of supporting at least 5,000 lbs. (22.2 kN). Connectors must be compatible with the anchorage or other system components. Do not use equipment that is not compatible. Non-compatible connectors may unintentionally disengage (See Figure 5). Connectors must be compatible in size, shape, and strength. If the connecting element to which a snap hook (shown) or carabiner attaches is undersized or irregular in shape, a situation could occur where the connecting element applies a force to the gate of the snap hook or carabiner. This force may cause the gate (of either a self-locking or a non-locking snap hook) to open, allowing the snap hook or carabiner to disengage from the connecting point. Self-locking snap hooks and carabiners are required.
- 2.5 MAKING CONNECTIONS:** Use only self-locking snap hooks and carabiners with this equipment. Use only connectors that are suitable for each application. Ensure all connections are compatible in size, shape and strength. Do not use equipment that is not compatible. Ensure all connectors are fully closed and locked.

Capital Safety connectors (snap hooks and carabiners) are designed to be used only as specified in each product's user's instructions. See Figure 6 for inappropriate connections. Capital Safety snap hooks and carabiners should not be connected:

- A. To a D-Ring to which another connector is attached.
- B. In a manner that would result in a load on the gate.

⚠ CAUTION: Large throat snap hooks should not be connected to standard size D-Rings or similar objects which will result in a load on the gate if the hook or D-Ring twists or rotates, unless the snap hook complies with ANSI Z359.12 and is equipped with a 3,600 lb (16 kN) gate. Check the marking on your snap hook to verify that it is appropriate for your application.

- C. In a false engagement, where features that protrude from the snap hook or carabiner catch on the anchor, and without visual confirmation seems to be fully engaged to the anchor point.
- D. To each other.
- E. Directly to webbing or rope lanyard or tie-back (unless the manufacturer's instructions for both the lanyard and connector specifically allows such a connection).
- F. To any object which is shaped or dimensioned such that the snap hook or carabiner will not close and lock, or that roll-out could occur.
- G. In a manner that does not allow the connector to align properly while under load.

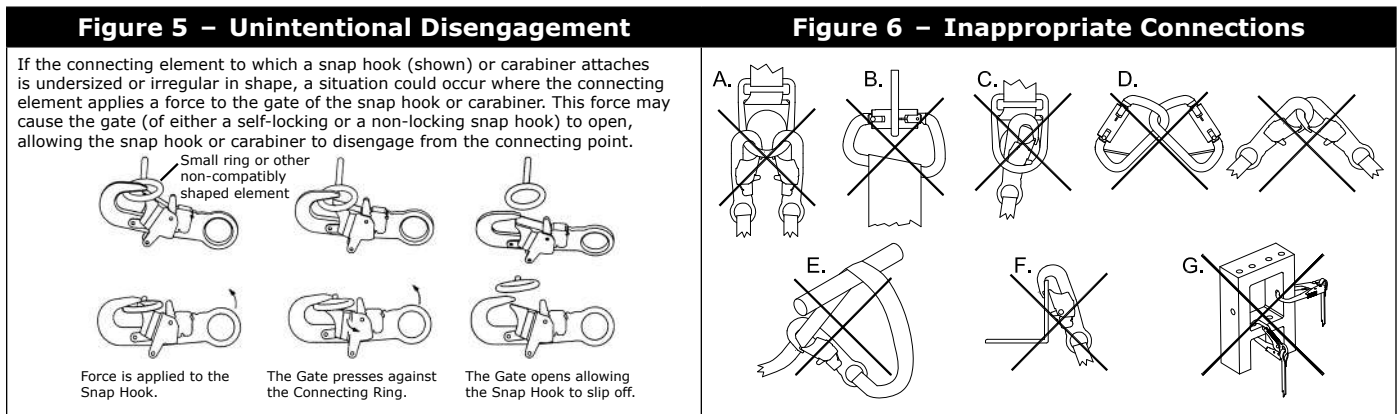

2 User: A person who performs activities at heights while protected by a personal fall protection system.

3 Authorized Person: For purposes of the Z359 standards, a person assigned by the employer to perform duties at a location where the person will be exposed to a fall hazard.

4 Rescuer: Person or persons other than the rescue subject acting to perform an assisted rescue by operation of a rescue system.

5 Competent Person: One who is capable of identifying existing and predictable hazards in the surroundings or working conditions which are unsanitary, hazardous, or dangerous to employees, and who has authorization to take prompt corrective measures to eliminate them.

6 Inspection Frequency: Extreme working conditions (harsh environments, prolonged use, etc.) may require increasing the frequency of competent person inspections.

2.6 CONNECTING SUBSYSTEMS: Connecting subsystems (self-retracting lifeline, lanyard, rope grab and lifeline, cable sleeve, etc.) must be suitable for your application (See section 1.1). See the subsystem manufacturer's instructions for additional information. Some harness models have web loop connection points. Do not use snap hooks to connect to web loops. Use a self-locking carabiner to connect to a web loop. Ensure the carabiner cannot cross-gate load (load against the gate rather than along the major axis of the carabiner). Some lanyards are designed to choke onto a web loop to provide a compatible connection. Lanyards may be sewn directly to the web loop forming a permanent connection. Do not make multiple connections onto one web loop, unless choking two lanyards onto a properly sized web loop. To choke the lanyard on a web loop:

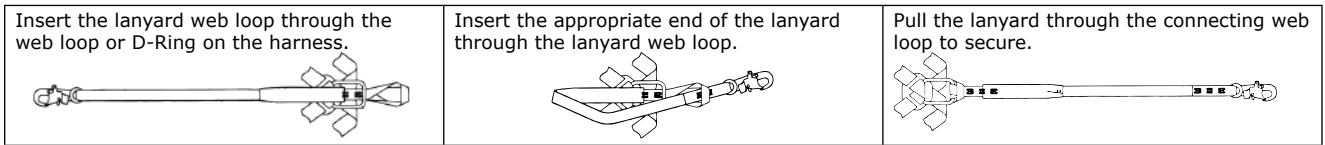

2.7 LANYARD PARKING ATTACHMENT: Figure 7 illustrates Lanyard Parking Attachments. The Lanyard Parking Attachment is for attaching the free end of a Lanyard or harness mounted Self-Retracting Device when not connected to an Anchorage Connection Point for purposes of fall protection. Lanyard Parking Attachments shall never be used as a Fall Protection Attachment Element.

Figure 7 – Lanyard Parking Attachments

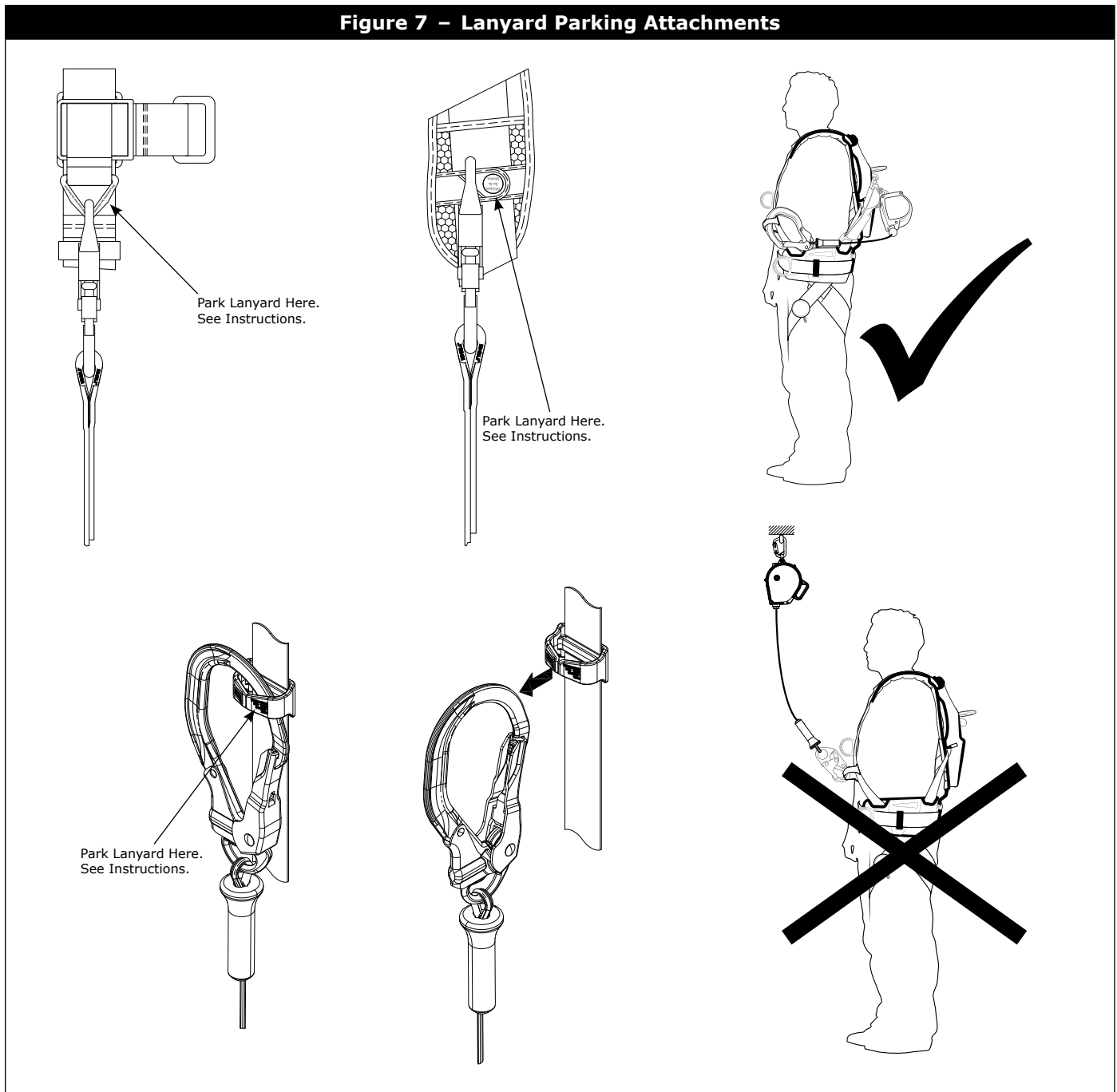

3.0 HARNESS USE

⚠ CAUTION: Do not alter or intentionally misuse this equipment. Consult Capital Safety when using this equipment in combination with components or subsystems other than those described in this manual. Some subsystem and component combinations may interfere with the operation of this equipment. Use caution when using this equipment around moving machinery, electrical and chemical hazards, and sharp edges.

⚠ WARNING: Consult your doctor if there is reason to doubt your fitness to safely absorb the shock from a fall arrest. Age and fitness seriously affect a worker's ability to withstand falls. Pregnant women or minors must not be exposed to fall hazards and fall arrest forces.

3.1 BEFORE EACH USE of this equipment inspect it according to the "Inspection and Maintenance Log" (Table 1).

3.2 PLAN your system before use. Consider all factors that will affect your safety during use of this equipment. The following list gives important points to consider when planning your system:



- **ANCHORAGE:** Select an anchorage that meets the requirements specified in "Limitations and Requirements".
- **SHARP EDGES:** Avoid working where system components may be in contact with, or abrade against, unprotected sharp edges.
- **AFTER A FALL:** Components which have been subjected to the forces of arresting a fall must be removed from service and destroyed.
- **RESCUE:** The employer must have a rescue plan when using this equipment. The employer must have the ability to perform a rescue quickly and safely.

3.3 BUCKLES: ExoFit Strata Full Body Harnesses are equipped with various buckles for fastening Leg Straps, Chest Straps, Body Belts, etc. See Figure 1 for the buckle types on your ExoFit Strata Harness. Figure 8 illustrates operation of each of the following buckles:

1. Tri-Lock Revolver™ Buckles:

- A. To fasten the Tri-Lock Revolver Buckle: Insert the Tab on the Revolver End in the Access Slot on the Receptor. Pull the Tab back in the slot until it clicks into locked position.
- B. To tighten the Web Strap, rotate the Revolver Ratchet Knobs away from your body. To loosen the Web Strap, pull out and rotate the Revolver Ratchet Knob toward your body while pulling the Web Strap out of the Revolver Spindle.
- C. To release the Tri-Lock Revolver Buckle: Squeeze the Lock Levers on each side of the Receptor. Slide the Tab forward and then pull it out of the Access Slot.

2. Duo-Lok™ Quick Connect Buckles:

- A. To fasten the Duo-Lok Quick Connect Buckle, insert the Tab into the Receptor until a click is heard.
- B. To adjust the attached Web Strap: Rotate the Webbing Lock to the Unlocked position . Pull the Web Strap forward or backward through the Buckle Slot to tighten or loosen. After adjustment, rotate the Webbing Lock to the Locked position .

⚠ IMPORTANT: The Webbing Lock does not lock or unlock engagement or disengagement of the buckle end. It only prevents or allows passage of the excess Web Strap through the Buckle Slot.

- C. To release the Duo-Lok Quick Connect Buckle: Squeeze the Lock Levers on each side of the Receptor. Pull the Tab out of the Receptor.

3. Tongue Buckles: Fasten and adjust Tongue Buckles by passing the Tongue through the Buckle Frame and inserting the Prong through the desired Grommet in the Tongue.

3.4 ADJUSTMENTS: ExoFit Strata Harnesses are equipped with an adjustable LIFTech™ Weight Distribution System that redistributes harness weight from the wearer's shoulders to their hips. They also have a pair of Revolver™ Torso Adjusters for adjusting the Shoulder Straps. Figure 9 illustrates adjustment of the LIFTech Weight Distribution System and Revolver Torso Adjusters:

1. LIFTech™ Weight Distribution System: To adjust the LIFTech system:

- A. Unzip the Back Pad to expose the LIFTech Adjustment Bar.
- B. Grasp the Adjustment Bar, depress the Adjustment Button, and slide the Adjustment Bar up or down until the Adjustment Button aligns in the desired hole. Maximum gap between the Shoulder Pads and wearer's shoulders should not exceed 1/4 in. (0.6 cm).
- C. Zip the Back Pad closed.

2. Revolver™ Torso Adjusters: To adjust the Shoulder Straps with the Revolver Torso Adjusters:

- A. Rotate the Revolver Ratchet Knobs as illustrated to tighten the Shoulder Straps.
- B. Pull out and rotate the Revolver Ratchet Knobs as illustrated to loosen the Shoulder Straps.

Figure 8 – Buckles

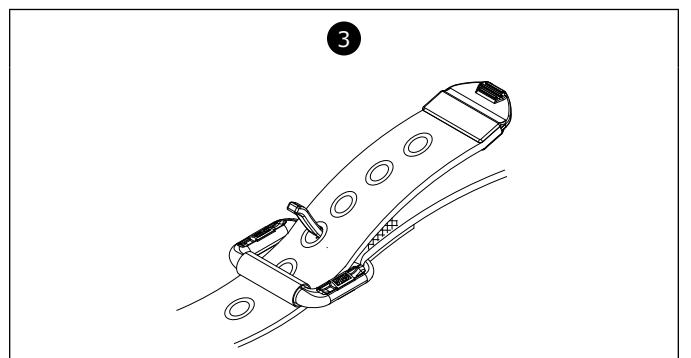
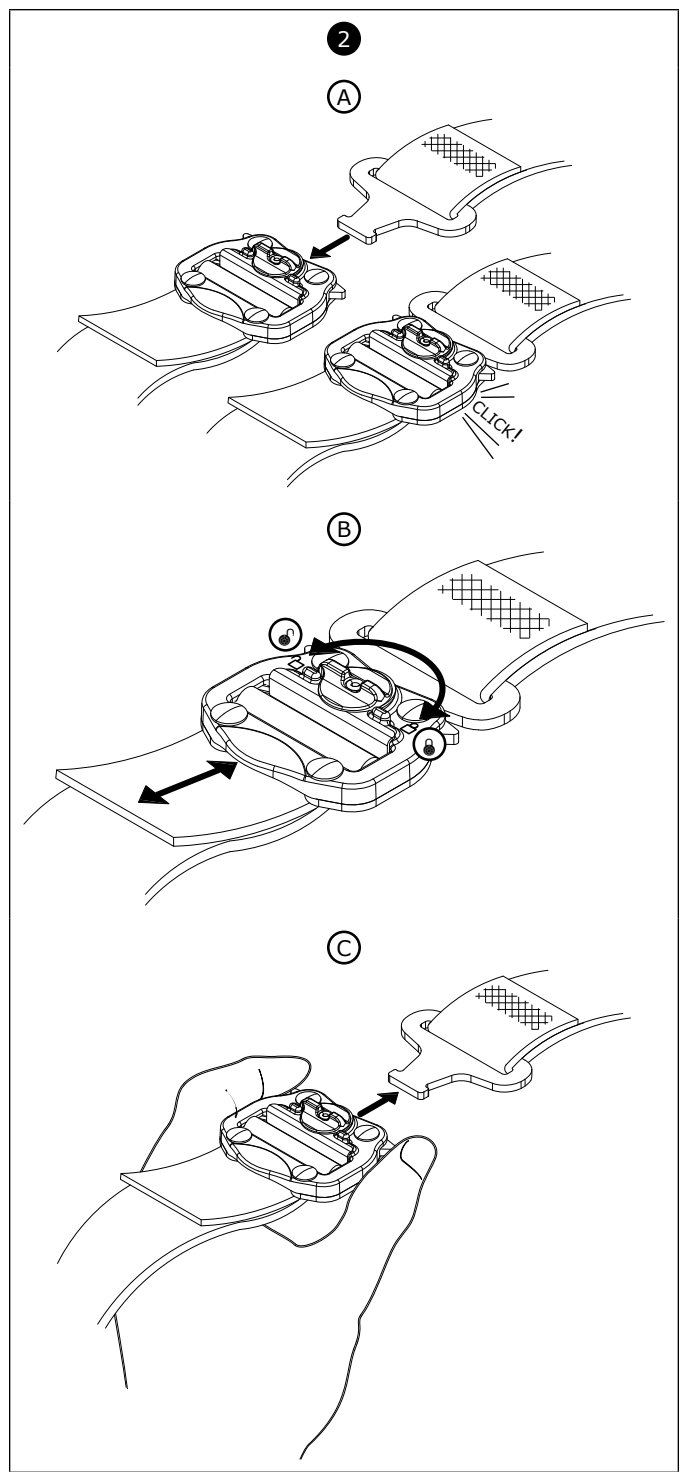
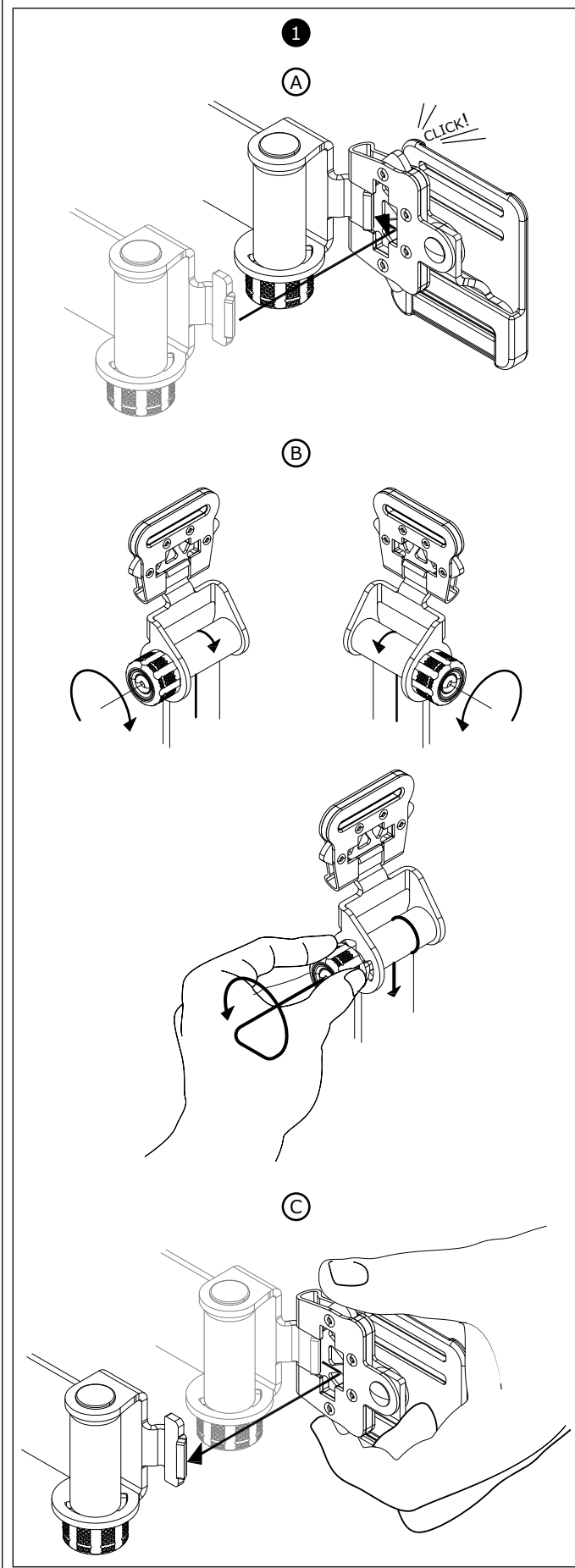
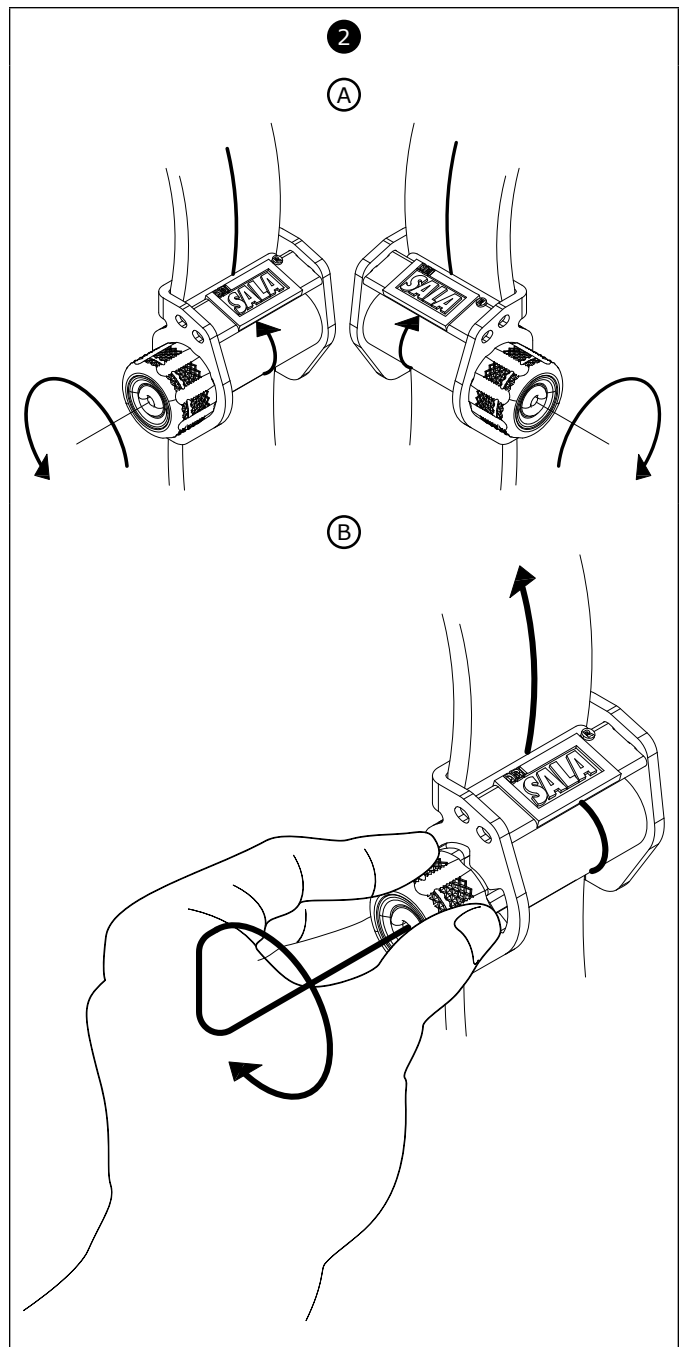
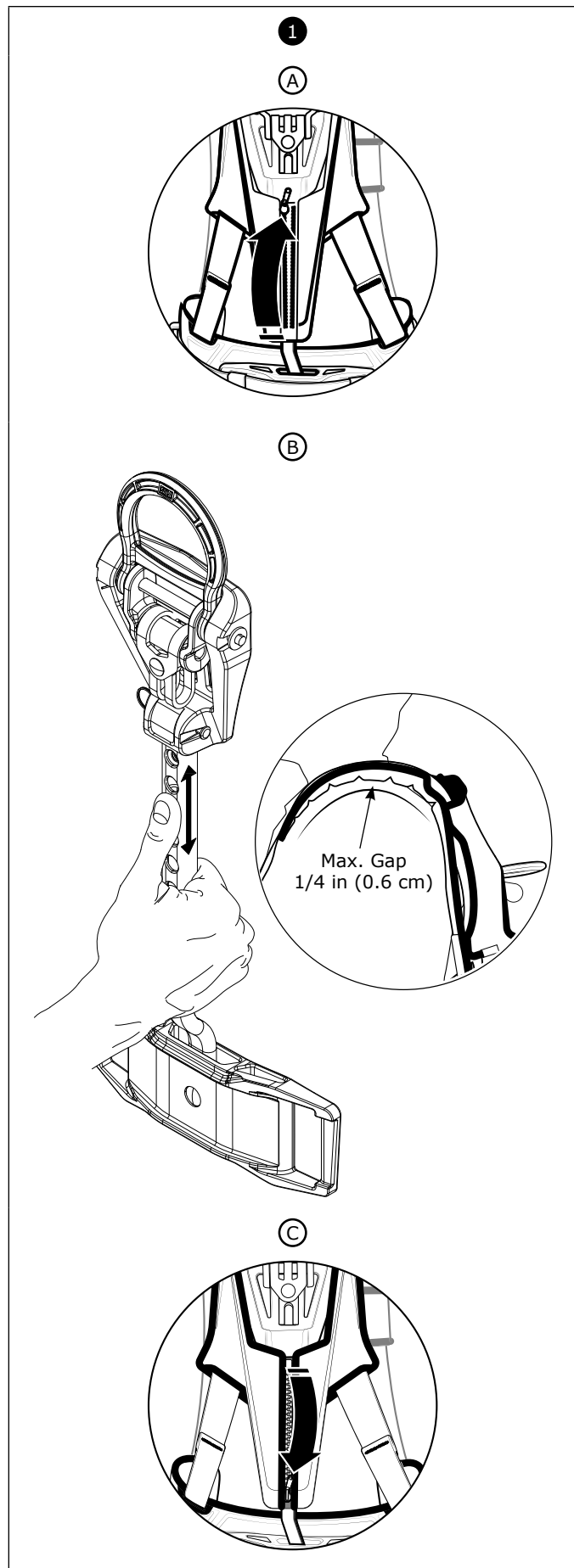

Figure 9 – Adjustments



3.5 EASY-LINK™ ATTACHMENTS: ExoFit Strata Full Body Harnesses are equipped with a patented Easy-Link™ System that integrates the Dorsal D-Ring with attachment elements for Harness-Mounted Self-Retracting Devices (SRDs). Figure 10 illustrates attachment of various DBI-SALA and Protecta Self-Retracting Devices. Other manufacturers' SRDs can also be mounted on the ExoFit Strata Harness in similar fashion. See the SRD manufacturer's instructions for requirements and installation instructions specific to the SRD.

① **IMPORTANT:** Contact DBI-SALA with any questions or concerns regarding compatibility of your SRD with the Easy-Link System.

Figure 10 – Easy Link™ Attachments

DBI-SALA Nano-Lok™ Edge SRDs

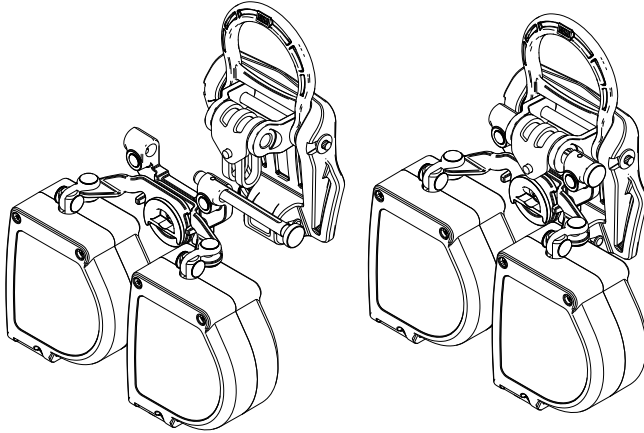

DBI-SALA Nano-Lok™ SRDs (Twin)

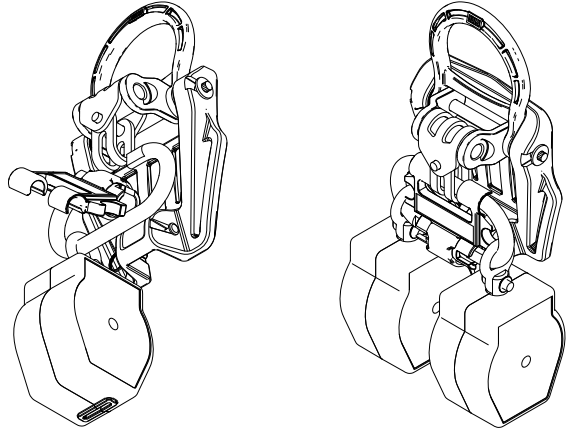

DBI-SALA Nano-Lok™ SRD (Single)

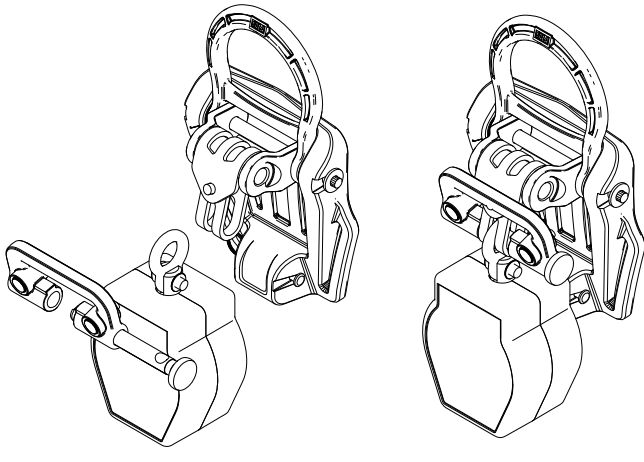

Protecta Rebel™ SRDs (Twin)

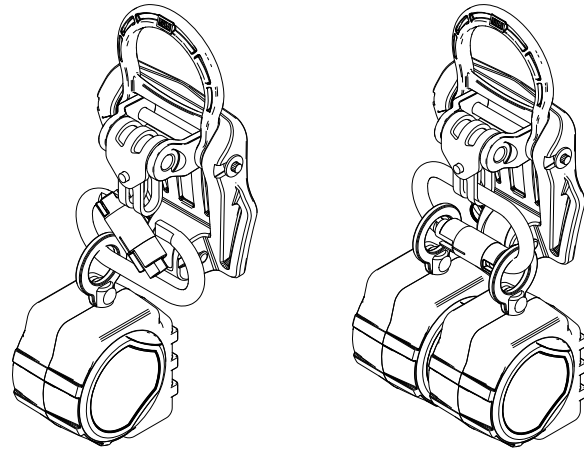

DBI-SALA Talon™ SRD (Twin)

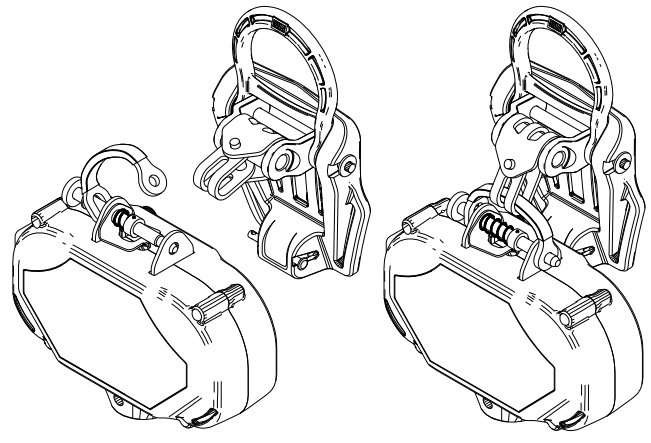

- 3.6 STORE-AWAY STERNAL D-RING ADJUSTMENT:** Some ExoFit Strata Harness models are equipped with a Store-Away Sternal D-Ring (see Figure 11). The Store-Away D-Ring folds flat against the Chest Strap when not in use, folds out perpendicular to the Chest Strap when in use. It can slide from side to side along the Chest Strap for proper positioning.

① **IMPORTANT:** Per ANSI/ASSE Z359.11, all Single Point Attachment Elements (Sternal D-Ring, Dorsal D-Ring, etc.) shall be located laterally within 2 in. (51 mm) of the vertical centerline of the Full Body Harness.

Figure 11 – Store-Away Sternal D-Ring

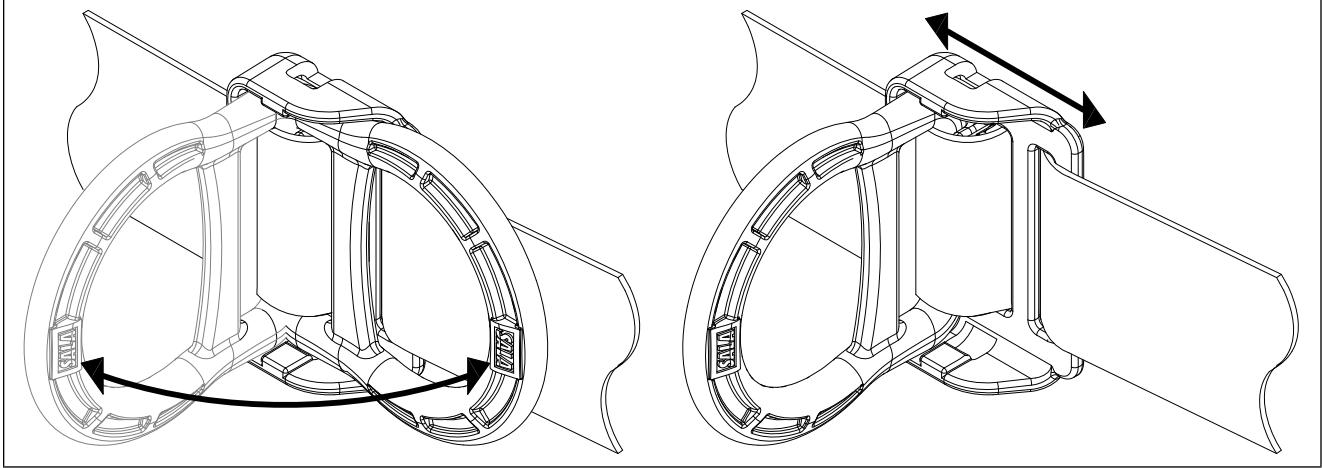

- 3.7 TOOL BAG ATTACHMENT:** Figure 12 illustrates attachment of a Tool Bag on the ExoFit Strata Harness. To mount the Tool Bag on the harness, thread the Waist Belt on the harness through the Belt Loops on the Hip/Lumbar Pad and Tool Bag.

① **IMPORTANT:** Combined weight of the harness wearer, clothing, tools, etc. shall not exceed the 'Capacity' stated in "Section 1.4 Limitations".

Figure 12 – Tool Bag Attachment

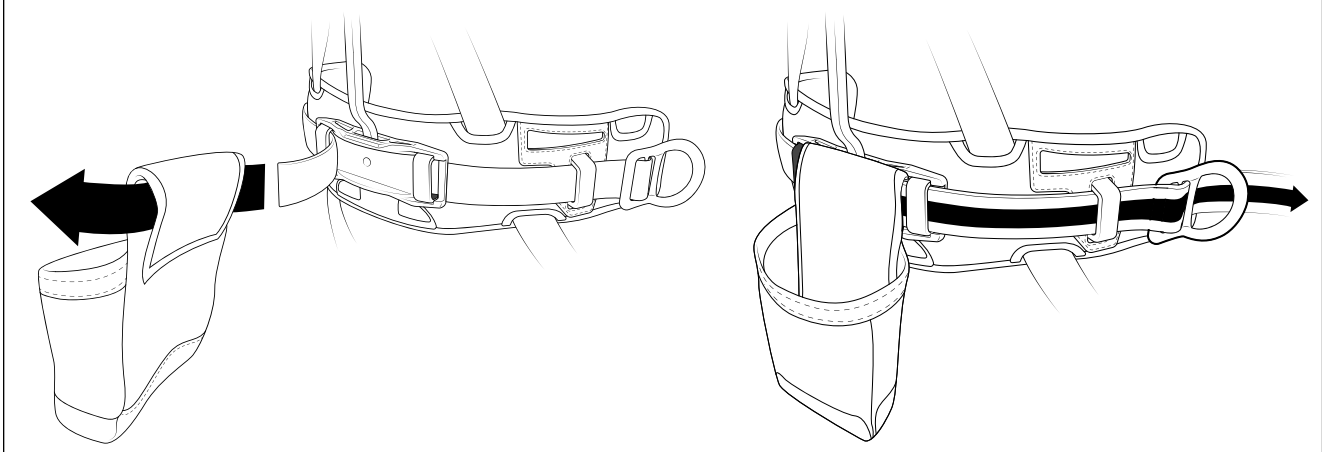

- 3.8 DONNING AND FITTING THE EXOFIT STRATA FULL BODY HARNESS:** Figure 13 illustrates donning and fitting of the ExoFit Strata Full Body Harness. Prior to each use, inspect the harness per the checklist on the "Inspection and Maintenance Log (Table 1)". To don and fit the harness:

NOTE: Procedures for buckling and adjusting the straps on you ExoFit Strata Harness will vary with the harness model. See Sections 3.3 thru 3.4 and Figures 8 thru 9 for details.

1. Lift up and hold the harness by the back Dorsal D-Ring on the Easy-Link System. Ensure the straps are not twisted.
2. Grasp the Shoulder Straps and slip the harness onto one arm. The Dorsal D-Ring will be located on your back side. Ensure that the straps are not tangled and hang freely. Slip your free arm into the harness and position the Shoulder Straps on top of your shoulders. The Chest Strap and Chest Buckle will be positioned on the front side when worn properly.

3. Reach between your legs and grasp the Leg Strap on your right side. Bring the strap up between your legs; buckle to the mating receptor on you right hip, and adjust the Leg Strap for a snug comfortable fit (see Section 3.3 for buckle operation). When properly adjusted, tuck the loose end of the Leg Strap under the Strap Keeper. Repeat this process to buckle and adjust the left Leg Strap.
4. Adjust and buckle the Tongue Buckle Waist Belt (see Section 3.3 for Tongue Buckle operation).
5. Buckle and adjust the Chest Strap (see Section 3.3 for buckle operation). The Chest Strap should be 6 in. (15 cm) down from the to of your shoulders. When properly adjusted, tuck the loose end of the Chest Strap under the Strap Keeper.
6. Adjust the Shoulder Straps for a Snug Fit with the Revolver Torso Adjusters (see Section 3.4 for Torso Adjuster operation). Left and right sides of Shoulder Straps should be adjusted to the same length and the Chest Strap should be centered on your lower chest, 6 in. (15 cm) down from the shoulders. The back Dorsal D-Ring should be centered between your Shoulder Blades. The front Sternal D-Ring, if present, should be located laterally within 2 in. (51 mm) of the vertical centerline of the harness (see Section 3.6 for Store-Away D-Ring adjustment).
7. If necessary, have someone adjust the LIFTech Weight Distribution System so harness weight is distributed from your shoulders to your hips (see Section 3.4. for LIFTech instructions).

Figure 13 – Donning and Fitting the ExoFit Strata Full Body Harness

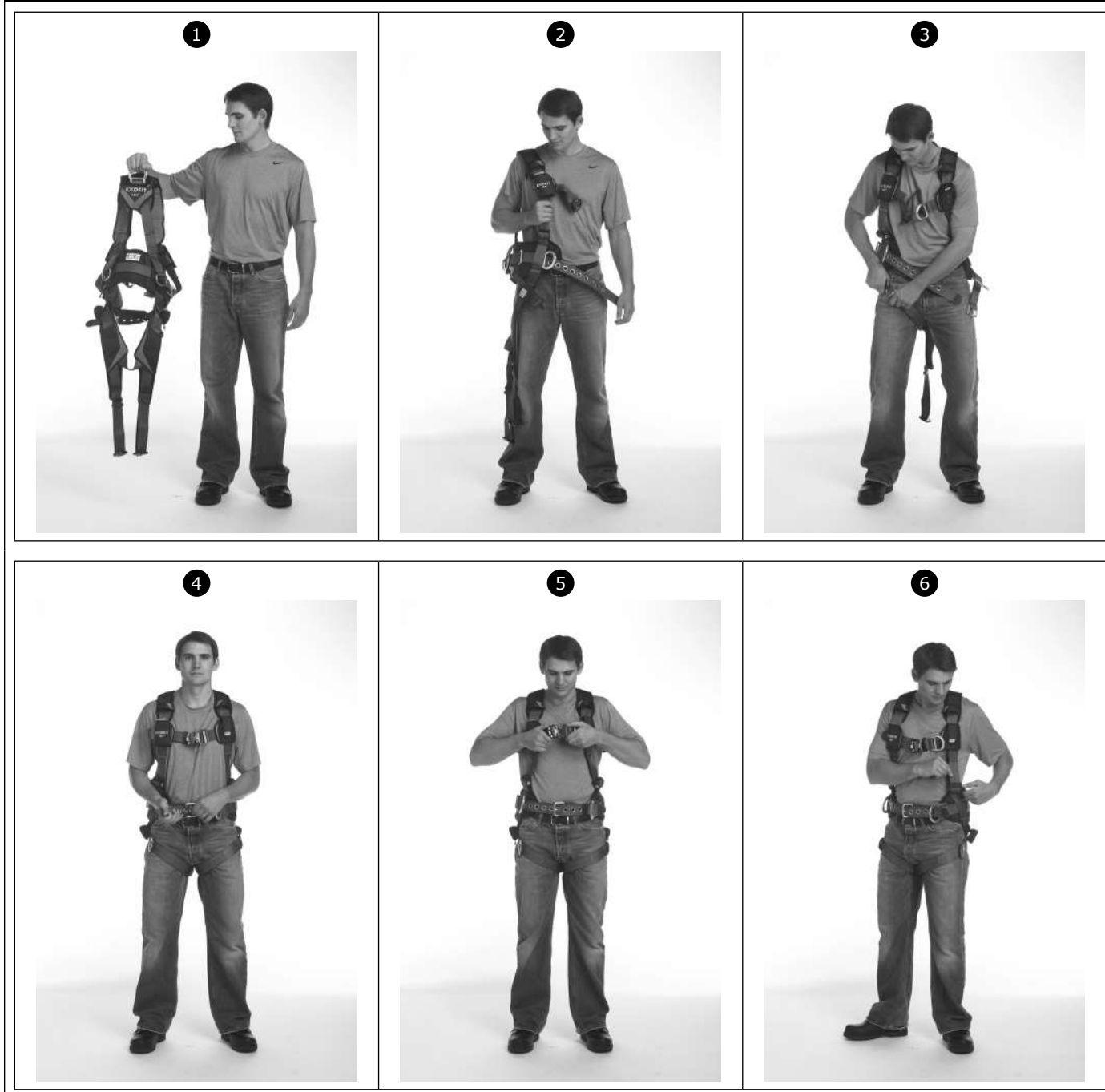

3.9 USE OF FALL ARREST D-RING OR ATTACHMENT ELEMENT: For Fall Arrest applications connect to the Dorsal D-ring or attachment element on your back, between your shoulder blades. Side D-rings, if present, are for Positioning or Restraint applications only. Shoulder D-rings are for Rescue or Retrieval applications only. The front Sternal D-ring is for Ladder Climbing or Positioning. D-rings on a Suspension Seat are for Suspension or Positioning applications only. (See Section 1.1.).

3.10 MAKING CONNECTIONS: When using a hook to connect to an anchorage or when coupling components of the system together, ensure roll-out cannot occur. Roll-out occurs when interference between the hook and mating connector causes the hook gate to unintentionally open and release. Self-locking snap hooks and carabiners should be used to reduce the possibility of roll-out. Do not use hooks or connectors that will not completely close over the attachment object. See subsystem manufacturer’s instructions for more information on making connections.

3.11 CONNECTING SYSTEM COMPONENTS: After fitting the ExoFit Strata Harness the user may then connect to other system components. Follow the guidelines in Section 2 and the manufacturer’s instructions included with the component.

3.12 SUSPENSION TRAUMA STRAP: The ExoFit Strata Full Body Harness is equipped with Suspension Trauma Straps (Figure 14) to help prolong allowable suspension time in the event of a fall from height. They should only be used in situations where a fall has occurred or for training. To use the Suspension Trauma Straps:

1. Unzip the Trauma Strap Pouch on each hip of the harness and deploy the Suspension Straps (Figure 14A).
2. Raise the ends of the straps to access the hook and loops. Insert the hook into the loop that provides the desired strap length.
3. Lower the Suspension Strap and step onto the strap to alleviate pressure of the harness leg straps on the legs (Figure 14B). Adjust the hook/loop combination for optimal comfort.

⚠ WARNING: Maintain an upright position following suspension. Do not lay down. Seek medical attention following a suspension.

4.0 INSPECTION

⚠ WARNING: If the full body harness has been subjected to fall arrest or impact forces it must be immediately removed from service and destroyed.

4.1 I-SAFE™ RFID TAG: The i-Safe™ RFID tag on the ExoFit Strata Harness (see Figure 15) can be used in conjunction with the i-Safe handheld reading device and the web based portal to simplify inspection and inventory control and provide records for your fall protection equipment.

4.2 INSPECTION FREQUENCY: The ExoFit Strata Full Body Harness must be inspected at the intervals defined in Section 2.2. Inspection procedures are described on the "Inspection and Maintenance Log" (Table 1).

4.3 DEFECTS: If inspection reveals a defective condition, remove unit from service immediately and destroy.

4.4 PRODUCT LIFE: The functional life of ExoFit Strata Harnesses is determined by work conditions and maintenance. As long as the product passes inspection criteria, it may remain in service.

① NOTE: Only DBI-SALA or parties authorized in writing may make repairs to this equipment.

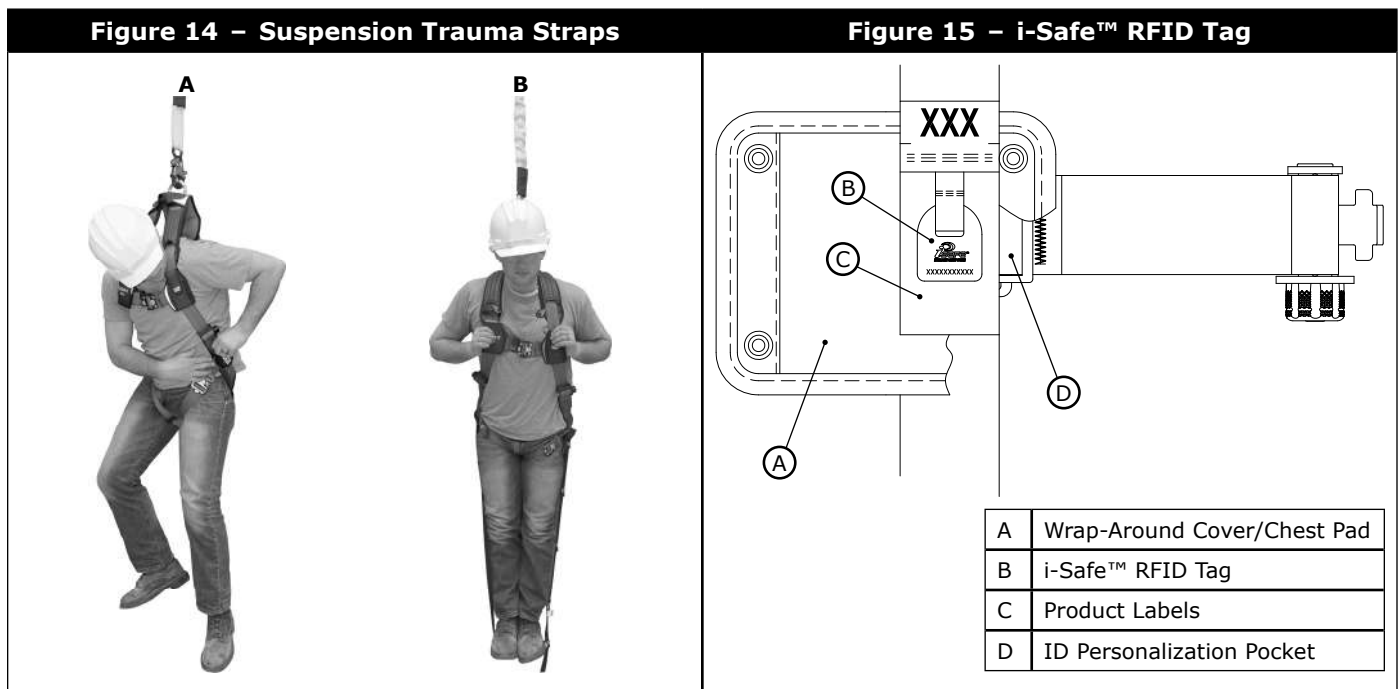

5.0 MAINTENANCE, SERVICING, STORAGE

5.1 CLEANING INSTRUCTIONS: Clean the ExoFit Strata Full Body Harness as follows:

1. Spot clean the harness with water and a mild soap solution.

ⓘ **IMPORTANT:** Use a bleach-free detergent when washing the harness and pads. Fabric softener or dryer sheets **SHOULD NOT** be used when laundering and drying the harness and pads.

2. Water temperature for wash and rinse must not exceed 160° F (70° C).
3. The harness and pads may be air dried or tumble dried on low heat not exceeding 200° F (90° C).

ⓘ **NOTE:** More information on cleaning is available from DBI-SALA. If you have questions concerning the condition of your harness, or have any doubt about putting it into service, contact DBI-SALA.

5.2 AUTHORIZED SERVICE: Additional maintenance and servicing procedures must be completed by a factory authorized service center. Authorization must be in writing. Do not attempt to disassemble the unit.

5.3 STORAGE AND TRANSPORT: Store and transport the ExoFit Strata Full Body Harness in a cool, dry, clean environment out of direct sunlight. Avoid areas where chemical vapors may exist. Thoroughly inspect the harness after extended storage.

6.0 LABELING:

Figure 16 illustrates product labels and their location on the ExoFit Strata Full Body Harness. All labeling must be present and fully legible.

Figure 16 – Labeling

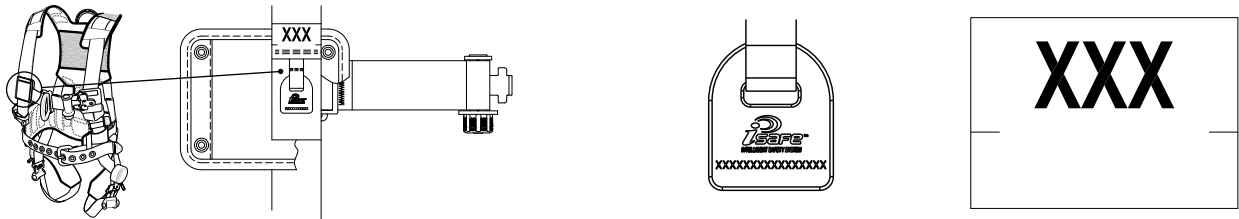

9503020 Rev. E	<p>ANSI Z359.11-2014 ANSI Z359 Recognizes the use of this harness only within the capacity range of: 130-310 lbs.</p> <p>Model No.: Mfrd.(yrl/mo): Lot: Stds:</p>	<table border="1" style="width: 100%; border-collapse: collapse;"> <tr> <th style="width: 50%;">PRODUCT COMPLIANCE</th> <th style="width: 50%;">DO NOT REMOVE THIS LABEL</th> </tr> <tr> <td colspan="2">This product complies with the following standards only if marked with the corresponding letter code under the "Stds" section.</td> </tr> <tr> <td>A = ANSI Z359.1</td> <td>D = ASTM F887</td> </tr> <tr> <td>B = OSHA</td> <td>E = ANSI Z359.3</td> </tr> <tr> <td>C = ANSI A10.32</td> <td>F = ANSI Z359.4</td> </tr> <tr> <td></td> <td>G = ANSI Z359.11</td> </tr> </table> <p>USER IDENTIFICATION Mark label with permanent marker _____</p>	PRODUCT COMPLIANCE	DO NOT REMOVE THIS LABEL	This product complies with the following standards only if marked with the corresponding letter code under the "Stds" section.		A = ANSI Z359.1	D = ASTM F887	B = OSHA	E = ANSI Z359.3	C = ANSI A10.32	F = ANSI Z359.4		G = ANSI Z359.11
PRODUCT COMPLIANCE	DO NOT REMOVE THIS LABEL													
This product complies with the following standards only if marked with the corresponding letter code under the "Stds" section.														
A = ANSI Z359.1	D = ASTM F887													
B = OSHA	E = ANSI Z359.3													
C = ANSI A10.32	F = ANSI Z359.4													
	G = ANSI Z359.11													

9500340 Rev. J	<p>⚠ WARNING Manufacturer's instructions must be read and understood prior to use. Instructions supplied with this product at time of shipment must be followed. Failure to do so could result in serious injury or death. Contact Capital Safety if instruction sheet is needed. Inspect before each use. Do not use if wear or damage is present. This body harness is intended to be used to arrest the most severe free falls. Items subjected to fall arrest or impact forces must be immediately removed from service and destroyed. Connecting snap and d-ring must be compatible in size, shape, and strength. This item is not flame or heat resistant. Repairs only to be performed by Capital Safety. Equipment modification or misuse voids warranty.</p>	<p>DBI SALSA www.capitalsafety.com Capital Safety Red Wing, MN, USA +1-800-328-6146</p> <p>Full Body Harness Material: Polyester Webbing ANSI Capacity: 130-310 lbs. OSHA Capacity: 420 lbs.</p> <table border="1" style="width: 100%; border-collapse: collapse;"> <tr> <th style="text-align: center;">⚠ WARNING</th> </tr> <tr> <td>Do not exceed the capacity of this or other system components. Capacity is the combined weight for which the component is designed to be used. Combined weight includes the user's body weight, clothing, tools, and any objects carried. Contact Capital Safety for more information.</td> </tr> </table> <p>DO NOT REMOVE LABEL</p>	⚠ WARNING	Do not exceed the capacity of this or other system components. Capacity is the combined weight for which the component is designed to be used. Combined weight includes the user's body weight, clothing, tools, and any objects carried. Contact Capital Safety for more information.
⚠ WARNING				
Do not exceed the capacity of this or other system components. Capacity is the combined weight for which the component is designed to be used. Combined weight includes the user's body weight, clothing, tools, and any objects carried. Contact Capital Safety for more information.				

SERIAL NO.: SEE RFID TAG

DATE	INITIAL								

INSPECTION LOG

9503011 Rev. D	<p>A - Dorsal attachment element is for fall arrest, travel restraint, or rescue.</p> <p>B - Sternal attachment element is for fall arrest (feet first falls only, 2 ft. maximum free fall), travel restraint, or rescue.</p> <p>C - Frontal attachment element is for fall arrest (feet first falls only, 2 ft. maximum free fall), work positioning, travel restraint, or rescue.</p> <p>D - Shoulder attachment elements are for rescue or entry/retrieval.</p> <p>E - Waist, rear attachment element is for travel restraint.</p> <p>F - Hip attachment elements are for work positioning or travel restraint.</p>
----------------	--

Table 1 – Inspection and Maintenance Log

Serial Number(s):	Date Purchased:
Model Number:	Date of First Use:

Inspection Date:	Inspected By:
-------------------------	----------------------

Component:	Inspection: <i>(See Section 2.2 for Inspection Frequency)</i>	User	Competent Person
Harness Hardware (Diagram 1)	Inspect harness hardware including buckles (1), adjusters (2), D-rings (3), Easy-Link (4), LIFTech (5), loop keepers (6), lanyard parking (7), etc. These items must not be damaged, broken, or distorted, and must be free of sharp edges, burrs, cracks, worn parts, or corrosion. PVC coated hardware must be free of cuts, rips, tears, holes, etc. in the coating to ensure non-conductivity. Ensure buckles and adjusters work smoothly.	<input type="checkbox"/>	<input type="checkbox"/>
Webbing & Stitching (Diagram 2)	Inspect webbing; material must be free of frayed, cut, or broken fibers. Check for tears, abrasions, mold, burns, or discoloration. Inspect stitching; Check for pulled or cut stitches. Broken stitches may be an indication that the harness has been impact loaded and must be removed from service.	<input type="checkbox"/>	<input type="checkbox"/>
Stitched Impact Indicators (Diagram 3)	The Stitched Impact Indicators are sections of webbing lapped back on themselves and secured with a specific stitch pattern. The stitch pattern is designed to release when the harness arrests a fall or is exposed to equivalent force. If an Impact Indicator has been activated (indicated), the harness must be removed from service and destroyed.	<input type="checkbox"/>	<input type="checkbox"/>
Labels	All labels should be present and fully legible. See Figure 16.	<input type="checkbox"/>	<input type="checkbox"/>
System & Subsystem Components	Inspect each system component or subsystem according to the manufacturer’s instructions.	<input type="checkbox"/>	<input type="checkbox"/>

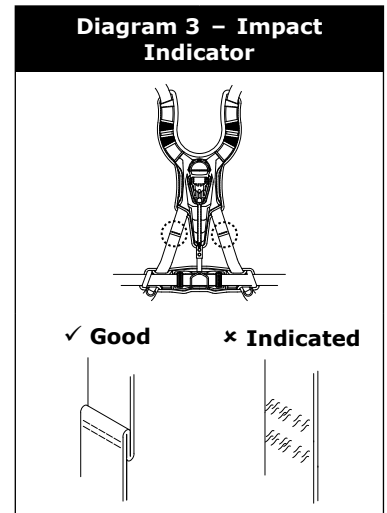
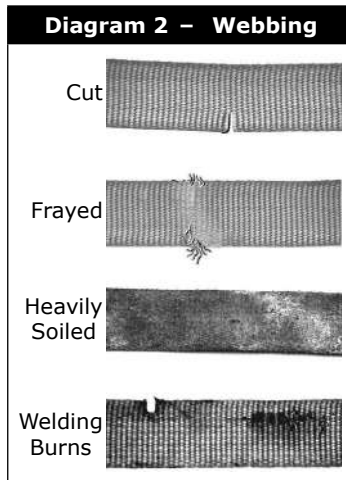
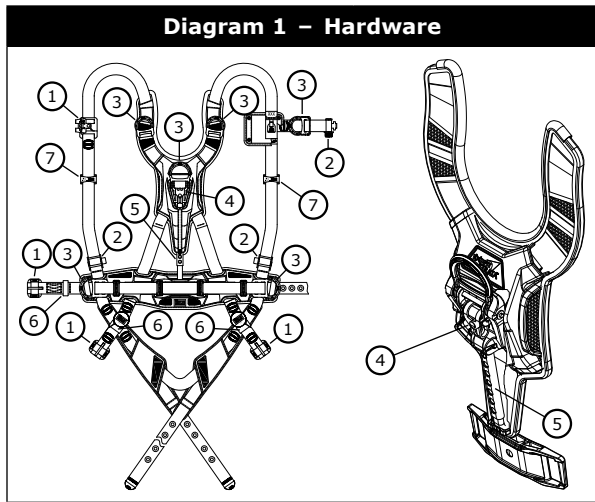

Corrective Action/Maintenance:	Approved By:
	Date:
Corrective Action/Maintenance:	Approved By:
	Date:
Corrective Action/Maintenance:	Approved By:
	Date:
Corrective Action/Maintenance:	Approved By:
	Date:
Corrective Action/Maintenance:	Approved By:
	Date:
Corrective Action/Maintenance:	Approved By:
	Date:
Corrective Action/Maintenance:	Approved By:
	Date:
Corrective Action/Maintenance:	Approved By:
	Date:

① **NOTE:** *These are general requirements and information provided by ANSI/ASSE Z359, the Manufacturer of this equipment may impose more stringent restrictions on the use of the products they manufacture, see the Manufacturer's instructions.*

1. It is essential that the users of this type of equipment receive proper training and instruction, including detailed procedures for the safe use of such equipment in their work application. ANSI/ASSE Z359.2, Minimum Requirements for a Comprehensive Managed Fall Protection Program, establishes guidelines and requirements for an employer's managed fall protection program, including policies, duties and training; fall protection procedures; eliminating and controlling fall hazards; rescue procedures; incident investigations; and evaluating program effectiveness.
2. Correct fit of a Full Body Harness is essential to proper performance. Users must be trained to select the size and maintain the fit of their Full Body Harness.
3. Users must follow manufacturer's instructions for proper fit and sizing, paying particular attention to ensure that buckles are connected and aligned correctly, leg straps and shoulder straps are kept snug at all times, chest straps are located in the middle chest area and leg straps are positioned and snug to avoid contact with the genitalia should a fall occur.
4. Full Body Harnesses which meet ANSI/ASSE Z359.11 are intended to be used with other components of a Personal fall Arrest system that limit maximum arrest forces to 1800 pounds (8 kn) or less.
5. Suspension intolerance, also called suspension trauma or orthostatic intolerance, is a serious condition that can be controlled with good harness design, prompt rescue and post fall suspension relief devices. A conscious user may deploy a suspension relief device allowing the user to remove tension from around the legs, freeing blood flow, which can delay the onset of suspension intolerance. An attachment element extender is not intended to be attached directly to an anchorage or anchorage connector for fall arrest. An energy absorber must be used to limit maximum arrest forces to 1800 pounds (8 kn). the length of the attachment element extender may affect free fall distances and free fall clearance calculations.
6. Full Body Harness (FBH) Stretch, the amount the FBH component of a personal fall arrest system will stretch and deform during a fall, can contribute to the overall elongation of the system in stopping a fall. it is important to include the increase in fall distance created by FBH Stretch, as well as the FBH connector length, the settling of the user's body in the FBH and all other contributing factors when calculating total clearance required for a particular fall arrest system.
7. When not in use, unused lanyard legs that are still attached to a Full Body Harness D-ring should not be attached to a work positioning element or any other structural element on the Full Body Harness unless deemed acceptable by the competent person and manufacturer of the lanyard. this is especially important when using some types of "y" style lanyards, as some load may be transmitted to the user through the unused lanyard leg if it is not able to release from the harness. the lanyard parking attachment is generally located in the sternal area to help reduce tripping and entanglement hazards.
8. Loose ends of straps can get caught in machinery or cause accidental disengagement of an adjuster. All Full Body Harnesses shall include keepers or other components which serve to control the loose ends of straps.
9. Due to the nature of soft loop connections, it is recommended that soft loop attachments only be used to connect with other soft loops or carabiners. Snaphooks should not be used unless approved for the application by the manufacturer.

Sections 10-16 provide additional information concerning the location and use of various attachments that may be provided on this FBH.

- 10. Dorsal** – the dorsal attachment element shall be used as the primary fall arrest attachment, unless the application allows the use of an alternate attachment. the dorsal attachment may also be used for travel restraint or rescue. When supported by the dorsal attachment during a fall, the design of the Full Body Harness shall direct load through the shoulder straps supporting the user, and around the thighs. Supporting the user, post fall, by the dorsal attachment will result in an upright body position with a slight lean to the front with some slight pressure to the lower chest. considerations should be made when choosing a sliding versus fixed dorsal attachment element. Sliding dorsal attachments are generally easier to adjust to different user sizes, and allow a more vertical rest position post fall, but can increase FBH Stretch.
- 11. Sternal** – the sternal attachment may be used as an alternative fall arrest attachment in applications where the dorsal attachment is determined to be inappropriate by a competent person, and where there is no chance to fall in a direction other than feet first. Accepted practical uses for a sternal attachment include, but are not limited to, ladder climbing with a guided type fall arrester, ladder climbing with an overhead self-retracting lifeline for fall arrest, work positioning and rope access. the sternal attachment may also be used for travel restraint or rescue.

When supported by the sternal attachment during a fall, the design of the Full Body Harness shall direct load through the shoulder straps supporting the user, and around the thighs. Supporting the user, post fall, by the sternal attachment will result in roughly a sitting or cradled body position with weight concentrated on the thighs, buttocks and lower back. Supporting the user during work positioning by this sternal attachment will result in an approximate upright body position.

if the sternal attachment is used for fall arrest, the competent person evaluating the application should take measures to ensure that a fall can only occur feet first. This may include limiting the allowable free fall distance. it may be possible for a sternal attachment incorporated into an adjustable style chest strap to cause the chest strap to slide up and possibly choke the user during a fall, extraction, suspension, etc. The competent person should consider Full Body Harness models with a fixed sternal attachment for these applications.

- 12. Frontal** – the frontal attachment serves as a ladder climbing connection for guided type fall arresters where there is no chance to fall in a direction other than feet first, or may be used for work positioning. Supporting the user, post fall or during work positioning, by the frontal attachment will result in a sitting body position, with the upper torso upright, with weight concentrated on the thighs and buttocks. When supported by the frontal attachment the design of the Full Body Harness shall direct load directly around the thighs and under the buttocks by means of the sub-pelvic strap.
- if the frontal attachment is used for fall arrest, the competent person evaluating the application should take measures to ensure that a fall can only occur feet first. This may include limiting the allowable free fall distance.
- 13. Shoulder** – the shoulder attachment elements shall be used as a pair, and are an acceptable attachment for rescue and entry/retrieval. the shoulder attachment elements shall not be used for fall arrest. it is recommended that the shoulder attachment elements be used in conjunction with a yoke which incorporates a spreader element to keep the Full Body Harness shoulder straps separate.
- 14. Waist, Rear** – the waist, rear attachment shall be used solely for travel restraint. the waist, rear attachment element shall not be used for fall arrest. Under no circumstances is it acceptable to use the waist, rear attachment for purposes other than travel restraint. the waist, rear attachment shall only be subjected to minimal loading through the waist of the user, and shall never be used to support the full weight of the user.
- 15. Hip** – the hip attachment elements shall be used as a pair, and shall be used solely for work positioning. the hip attachment elements shall not be used for fall arrest. Hip attachments are often used for work positioning by arborists, utility workers climbing poles and construction workers tying rebar and climbing on form walls. Users are cautioned against using the hip attachment elements (or any other rigid point on the Full Body Harness) to store the unused end of a fall arrest lanyard, as this may cause a tripping hazard, or, in the case multiple leg lanyards, could cause adverse loading to the Full Body Harness and the wearer through the unused portion of the lanyard.
- 16. Suspension Seat** – the suspension seat attachment elements shall be used as a pair, and shall be used solely for work positioning. the suspension seat attachment elements shall not be used for fall arrest. Suspension seat attachments are often used for prolonged work activities where the user is suspended, allowing the user to sit on the suspension seat formed between the two attachment elements. An example of this use would be window washers on large buildings.

User Inspection, Maintenance, and Storage of Equipment

Users of personal fall arrest systems shall, at a minimum, comply with all manufacturer instructions regarding the inspection, maintenance and storage of the equipment. the user's organization shall retain the manufacturer's instructions and make them readily available to all users. See ANSI/ASSE Z359.2, Minimum Requirements for a Comprehensive Managed Fall Protection Program, regarding user inspection, maintenance and storage of equipment.

1. In addition to the inspection requirements set forth in the manufacturer's instructions, the equipment shall be inspected by the user before each use and, additionally, by a competent person, other than the user, at interval of no more than one year for:
 - **Absence** or illegibility of markings.
 - **Absence** of any elements affecting the equipment form, fit or function.
 - **Evidence** of defects in, or damage to, hardware elements including cracks, sharp edges, deformation, corrosion, chemical attack, excessive heating, alteration and excessive wear.
 - **Evidence** of defects in or damage to strap or ropes including fraying, unsplicing, unlaying, kinking, knotting, roping, broken or pulled stitches, excessive elongation, chemical attack, excessive soiling, abrasion, alteration, needed or excessive lubrication, excessive aging and excessive wear.
2. Inspection criteria for the equipment shall be set by the user's organization. Such criteria for the equipment shall equal or exceed the criteria established by this standard or the manufacturer's instructions, whichever is greater.
3. When inspection reveals defects in, damage to, or inadequate maintenance of equipment, the equipment shall be permanently removed from service or undergo adequate corrective maintenance, by the original equipment manufacturer or their designate, before return to service.

Maintenance and Storage

1. Maintenance and storage of equipment shall be conducted by the user's organization in accordance with the manufacturer's instructions. Unique issues, which may arise due to conditions of use, shall be addressed with the manufacturer.
2. Equipment which is in need of, or scheduled for, maintenance shall be tagged as unusable and removed from service.
3. Equipment shall be stored in a manner as to preclude damage from environmental factors such as temperature, light, UV, excessive moisture, oil, chemicals and their vapors or other degrading elements.

U.S. PRODUCT WARRANTY, LIMITED REMEDY AND LIMITATION OF LIABILITY

WARRANTY: THE FOLLOWING IS MADE IN LIEU OF ALL WARRANTIES OR CONDITIONS, EXPRESS OR IMPLIED, INCLUDING THE IMPLIED WARRANTIES OR CONDITIONS OF MERCHANTABILITY OR FITNESS FOR A PARTICULAR PURPOSE.

Unless otherwise provided by applicable law, 3M fall protection products are warranted against factory defects in workmanship and materials for a period of one year from the date of installation or first use by the original owner.

LIMITED REMEDY: Upon written notice to 3M, 3M will repair or replace any product determined by 3M to have a factory defect in workmanship or materials. 3M reserves the right to require product be returned to its facility for evaluation of warranty claims. This warranty does not cover product damage due to wear, abuse, misuse, damage in transit, failure to maintain the product or other damage beyond 3M's control. 3M will be the sole judge of product condition and warranty options.

This warranty applies only to the original purchaser and is the only warranty applicable to 3M's fall protection products. Please contact 3M's customer service department at 800-328-6146 or via email at 3MFallProtection@mmm.com for assistance.

LIMITATION OF LIABILITY: TO THE EXTENT PERMITTED BY APPLICABLE LAW, 3M IS NOT LIABLE FOR ANY INDIRECT, INCIDENTAL, SPECIAL OR CONSEQUENTIAL DAMAGES INCLUDING, BUT NOT LIMITED TO LOSS OF PROFITS, IN ANY WAY RELATED TO THE PRODUCTS REGARDLESS OF THE LEGAL THEORY ASSERTED.



Fall Protection

USA

3833 SALA Way
Red Wing, MN 55066-5005
Toll Free: 800.328.6146
Phone: 651.388.8282
Fax: 651.388.5065
3Mfallprotection@mmm.com

Brazil

Rua Anne Frank, 2621
Boqueirão Curitiba PR
81650-020
Brazil
Phone: 0800-942-2300
falecoma3m@mmm.com

Mexico

Calle Norte 35, 895-E
Col. Industrial Vallejo
C.P. 02300 Azcapotzalco
Mexico D.F.
Phone: (55) 57194820
3msaludocupacional@mmm.com

Colombia

Compañía Latinoamericana de Seguridad S.A.S.
Carrera 106 #15-25 Interior 105 Manzana 15
Zona Franca - Bogotá, Colombia
Phone: 57 1 6014777
fallprotection-co@mmm.com

Canada

260 Export Boulevard
Mississauga, ON L5S 1Y9
Phone: 905.795.9333
Toll-Free: 800.387.7484
Fax: 888.387.7484
3Mfallprotection-ca@mmm.com

EMEA (Europe, Middle East, Africa)

EMEA Headquarters:
Le Broc Center
Z.I. 1re Avenue - BP15
06511 Carros Le Broc Cedex
France
Phone: + 33 04 97 10 00 10
Fax: + 33 04 93 08 79 70
informationfallprotection@mmm.com

Australia & New Zealand

95 Derby Street
Silverwater
Sydney NSW 2128
Australia
Phone: +(61) 2 8753 7600
Toll-Free : 1800 245 002 (AUS)
Toll-Free : 0800 212 505 (NZ)
Fax: +(61) 2 8753 7603
anzfallprotectionsales@mmm.com

Asia

Singapore:
1 Yishun Avenue 7
Singapore 768923
Phone: +65-6450 8888
Fax: +65-6552 2113
TotalFallProtection@mmm.com

Shanghai:

19/F, L'Avenue, No.99 Xian Xia Rd
Shanghai 200051, P R China
Phone: +86 21 62539050
Fax: +86 21 62539060
3MFallProtection-CN@mmm.com

Korea:

3M Korea Ltd
20F, 82, Uisadang-daero,
Yeongdeungpo-gu, Seoul
Phone: +82-80-033-4114
Fax: +82-2-3771-4271
TotalFallProtection@mmm.com

Japan:

3M Japan Ltd
6-7-29, Kitashinagawa, Shinagawa-ku, Tokyo
Phone: +81-570-011-321
Fax: +81-3-6409-5818
psd.jp@mmm.com

WEBSITE:
3M.com/FallProtection



EU DECLARATION OF CONFORMITY:
3M.com/FallProtection/DOC