



**Instructions for the following series products:**

U-BOLT ROOF ANCHORS

(See back page for specific model numbers.)

**USER INSTRUCTION MANUAL**  
**U-BOLT ROOF ANCHOR**

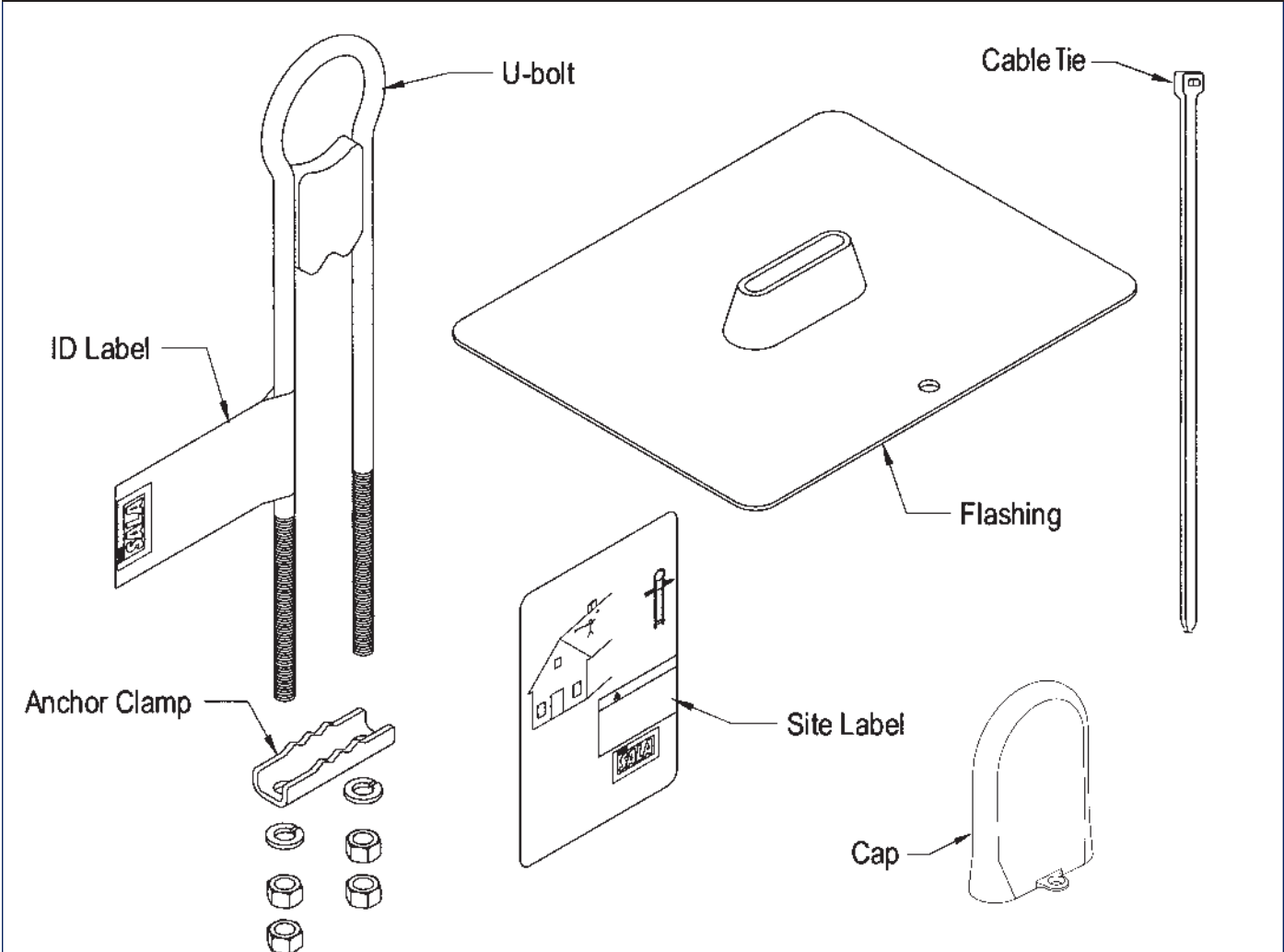
*This manual is intended to be used as part of an employee training program as required by OSHA.*

**WARNING:** This product is part of a personal fall arrest or restraint system. The user must follow the manufacturer's instructions for each component of the system. These instructions must be provided to the user of this equipment. The user must read and understand these instructions before using this equipment. Manufacturer's instructions must be followed for proper use and maintenance of this equipment. Alterations or misuse of this equipment, or failure to follow these instructions, may result in serious injury or death.

**IMPORTANT:** If you have questions on the use, care, or suitability of this equipment for your application, contact DBI/SALA.

**IMPORTANT:** Record the product identification information from the ID label in the inspection and maintenance log in section 9.0 of this manual.

**Figure 1 - U-bolt Roof Anchor Kit**



## **DESCRIPTION**

**2103670:** *Stainless steel U-bolt and anchor clamp, designed to be attached to a wood member (truss, rafter, cord, etc.) up to 2 x 8 inches. U-bolt includes a ring for connection of a personal fall arrest or restraint system. See Figure 1.*

**2103671:** *Same as 2103670, sized for 2 x 10 or 2 x 12-inch wood member.*

## **1.0 APPLICATIONS**

**1.1 PURPOSE:** DBI/SALA's U-bolt roof anchor is designed to be used as a permanently attached anchorage connector on wood frame structures. This anchorage connector is to be used as part of a personal fall arrest or restraint system. Do not attach a lifeline between two or more roof anchors. Do not hang, lift, or support tools or equipment from the roof anchor. Do not attach guylines for antennae, phone lines, etc.

- A. FALL ARREST:** The roof anchor is used as part of a personal fall arrest system. Personal fall arrest systems typically include a full body harness and a connecting subsystem (energy absorbing lanyard). The maximum permissible free fall is six feet.
- B. RESTRAINT:** The roof anchor is used as part of a restraint system. Restraint systems typically include a full body harness and a lanyard or restraint line to prevent the user from reaching a fall hazard (leading edge roof work). No vertical free fall is permitted.

**1.2 LIMITATIONS:** Consider the following application limitations before using this equipment:

- A. ROOF STRUCTURE:** These roof anchors are intended to be installed on wood members (truss, rafter, cord, etc.) from 2 x 4 inches to 2 x 12 inches. The roof structure must be capable of meeting the anchorage strength requirements specified in section 2.3. Do not use these roof anchors on members or materials (including steel) other than those specified in this manual.
- B. CAPACITY:** These roof anchors are designed for use by persons with a combined weight (person, clothing, tools, etc.) of no more than 310 lbs. No more than one person may be connected to a single roof anchor.
- C. FREE FALL:** Personal fall arrest systems used with these roof anchors must be rigged to limit the free fall to six feet (according to ANSI Z359.1). See subsystem manufacturer's instructions for more information.
- D. FALL CLEARANCE:** Ensure that adequate clearance exists in your fall path to prevent striking an object. The amount of clearance required is dependent on the type of connecting subsystem (energy absorbing lanyard, self retracting lifeline, etc.) and the anchorage location. See subsystem manufacturer's instructions for more information.
- E. ENVIRONMENTAL HAZARDS:** Use of this equipment in areas where environmental hazards are present may require additional precautions to reduce the possibility of injury to the user or damage to the equipment. Hazards may include, but are not limited to; high heat, caustic chemicals, corrosive environments, high voltage power lines, explosive or toxic gases, moving machinery, or sharp edges.
- F. TRAINING:** This equipment is intended to be used by persons trained in its correct application and use.

**1.3 APPLICABLE STANDARDS:** Refer to national standards, including ANSI Z359.1, and local state, and federal (OSHA) requirements for more information on personal fall arrest systems and associated components.

## **2.0 SYSTEM REQUIREMENTS**

**2.1 COMPATIBILITY OF CONNECTORS:** DBI/SALA equipment is designed for use with DBI/SALA approved components and subsystems only. Substitutions or replacements made with non-approved components or subsystems may jeopardize compatibility of equipment and may effect the safety and reliability of the complete system.

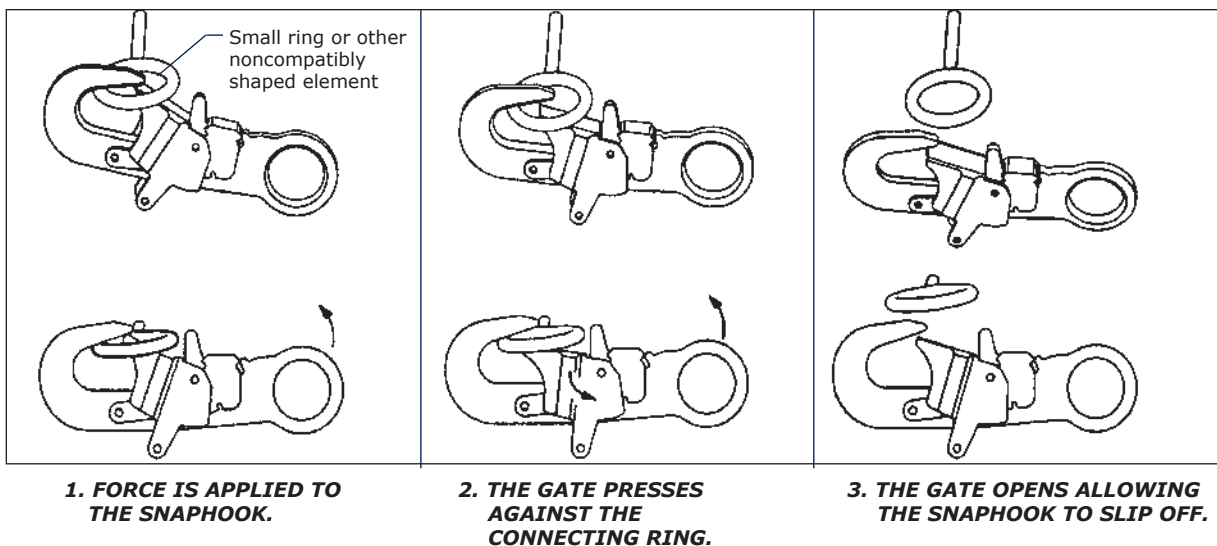
**COMPATIBILITY:** Connectors are considered to be compatible with connecting elements when they have been designed to work together in such a way that their sizes and shapes do not cause their gate mechanisms to inadvertently open regardless of how they become oriented.

Contact DBI/SALA if you have any questions about compatibility.

Connectors ( hooks, carabiners, and D-rings) must be capable of supporting at least 5,000 lbs. (22.2kN). Connectors must be compatible with the anchorage or other system components. Do not use equipment that is not compatible. Non-compatible connectors may unintentionally disengage. See Figure 2. Connectors must be compatible in size, shape, and strength. Self locking snap hooks and carabiners are required by ANSI Z359.1 and OSHA.

**Figure 2 - Unintentional Disengagement (Rollout)**

If the connecting element that a snaphook (shown) or carabiner attaches to is undersized or irregular in shape, a situation could occur where the connecting element applies a force to the gate of the snaphook or carabiner. This force may cause the gate (of either a self-locking or a non-locking snaphook) to open, allowing the snaphook or carabiner to disengage from the connecting point.

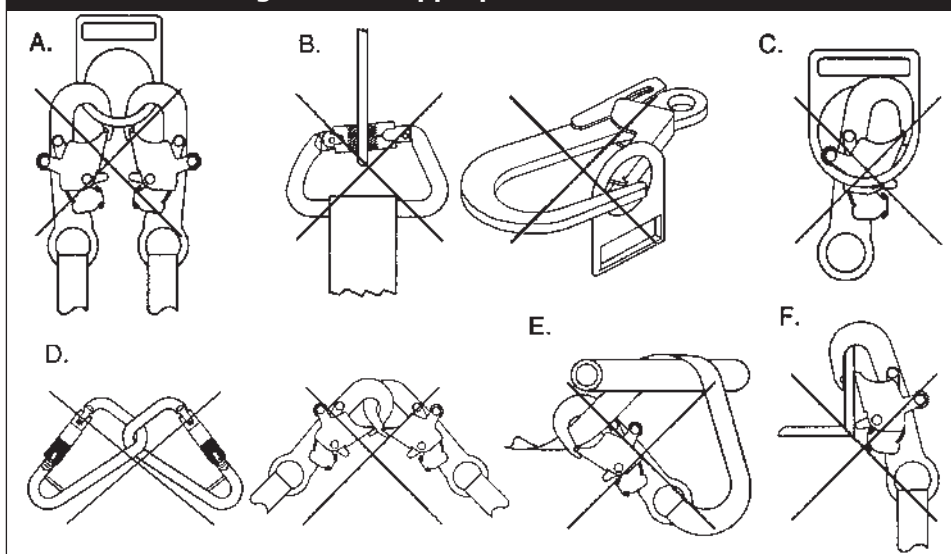


**2.2 MAKING CONNECTIONS:** Only use self-locking snap hooks and carabiners with this equipment. Only use connectors that are suitable to each application. Ensure all connections are compatible in size, shape and strength. Do not use equipment that is not compatible. Ensure all connectors are fully closed and locked.

DBI/SALA connectors (snap hooks and carabiners) are designed to be used only as specified in each product’s user’s instructions. See Figure 3 for inappropriate connections. DBI/SALA snap hooks and carabiners should not be connected:

- A. To a D-ring to which another connector is attached.
- B. In a manner that would result in a load on the gate.
- C. In a false engagement, where features that protrude from the snap hook or carabiner catch on the anchor and without visual confirmation seems to be fully engaged to the anchor point.
- D. To each other.

**Figure 3 - Inappropriate Connections**



- E. Directly to webbing or rope lanyard or tie-back (unless the manufacturer’s instructions for both the lanyard and connector specifically allows such a connection).

- F. To any object which is shaped or dimensioned such that the snap hook or carabiner will not close and lock, or that roll out could occur.

**2.3 ANCHORAGE STRENGTH:** The anchorage strength required is dependent upon the application:

- A. **FALL ARREST:** The roof anchor must be attached to a roof member capable of sustaining static loads in the directions permitted by the personal fall arrest system of at least: 3,600 lbs. with certification of a qualified person, or 5,000 lbs. without certification. See ANSI Z359.1 for certification definition. When more than one roof anchor is attached to a roof member, the strengths stated above must be met at each roof anchor location independently.

**FROM OSHA 1910.500 AND 1910.66:** Anchorages used for attachment of personal fall arrest systems shall be independent of any anchorage being used to support or suspend platforms, and capable of supporting at least 5,000 lbs. per user attached, or be designed, installed, and used as part of a complete PFAS which maintains a safety factor of at least two, and is under the supervision of a qualified person.

- B. **RESTRAINT:** The roof anchor must be attached to a roof member capable of sustaining static loads in the directions permitted by the restraint system of at least 3,000 lbs. When more than one roof anchor is attached to a roof member, the strengths stated above must be met at each roof anchor location independently.

### 3.0 OPERATION AND USE

**WARNING:** Do not alter or intentionally misuse this equipment. Consult with DBI/SALA if using this equipment with components or subsystems other than those described in this manual. Some subsystems and component combinations may interfere with the operation of this equipment.

**WARNING:** Do not use this system if you are unable to tolerate the impact from a fall arrest. Age and fitness can seriously affect your ability to withstand a fall. Pregnant women and minors must not use this equipment.

- 3.1 **BEFORE EACH USE** of this equipment, carefully inspect it according to steps listed in section 5.0 of this manual.

- 3.2 **PLAN** your fall arrest or restraint system before using this equipment. Consider all factors that will affect your safety during use of this equipment. Consider the following points when planning your system:

- A. **ANCHORAGE:** Select a rigid anchorage point that is capable of sustaining the loads specified in section 2.3. Locate the roof anchor according to section 3.3. For fall arrest applications, select anchorage locations that will minimize free fall and swing fall hazards. For restraint applications, locate the anchorages such that no vertical free fall is possible.

- B. **FREE FALL:** To avoid increased free fall distance, do not work above the anchorage level. Rig personal fall arrest systems so that the free fall is limited to six feet (ANSI Z359.1). Rig restraint systems such that no vertical free fall is possible.

- C. **FALL ARREST FORCES:** The personal fall arrest system must limit fall arrest forces to 1,800 lbs. when used with a full body harness. Do not use a body belt for fall arrest applications.

- D. **SWING FALLS:** See Figure 4. Swing falls occur when the anchorage point is not directly above the point where a fall occurs. The force of striking an object in a swing fall may cause serious injury. Minimize swing falls by working as directly below the anchorage point as possible. Do not permit a swing fall if injury could occur.

- E. **WORK ZONE:** See Figure 5. Do not extend your work zone more than 30 degrees from

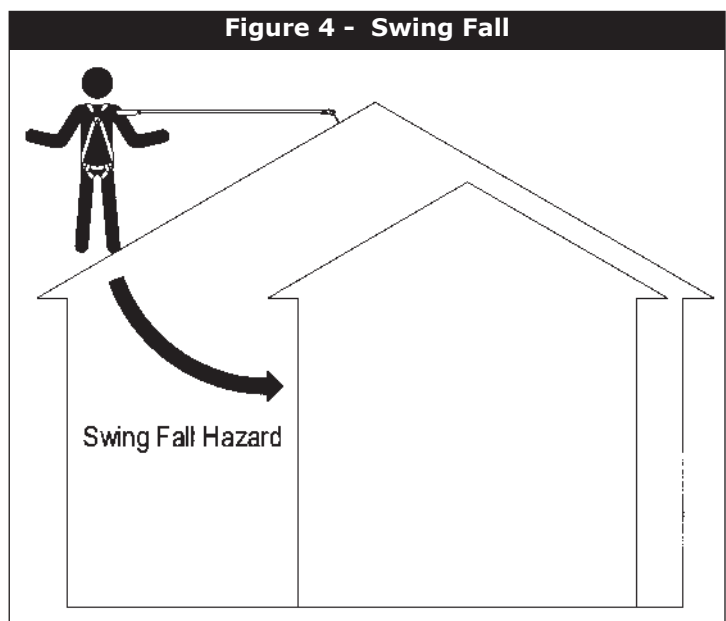
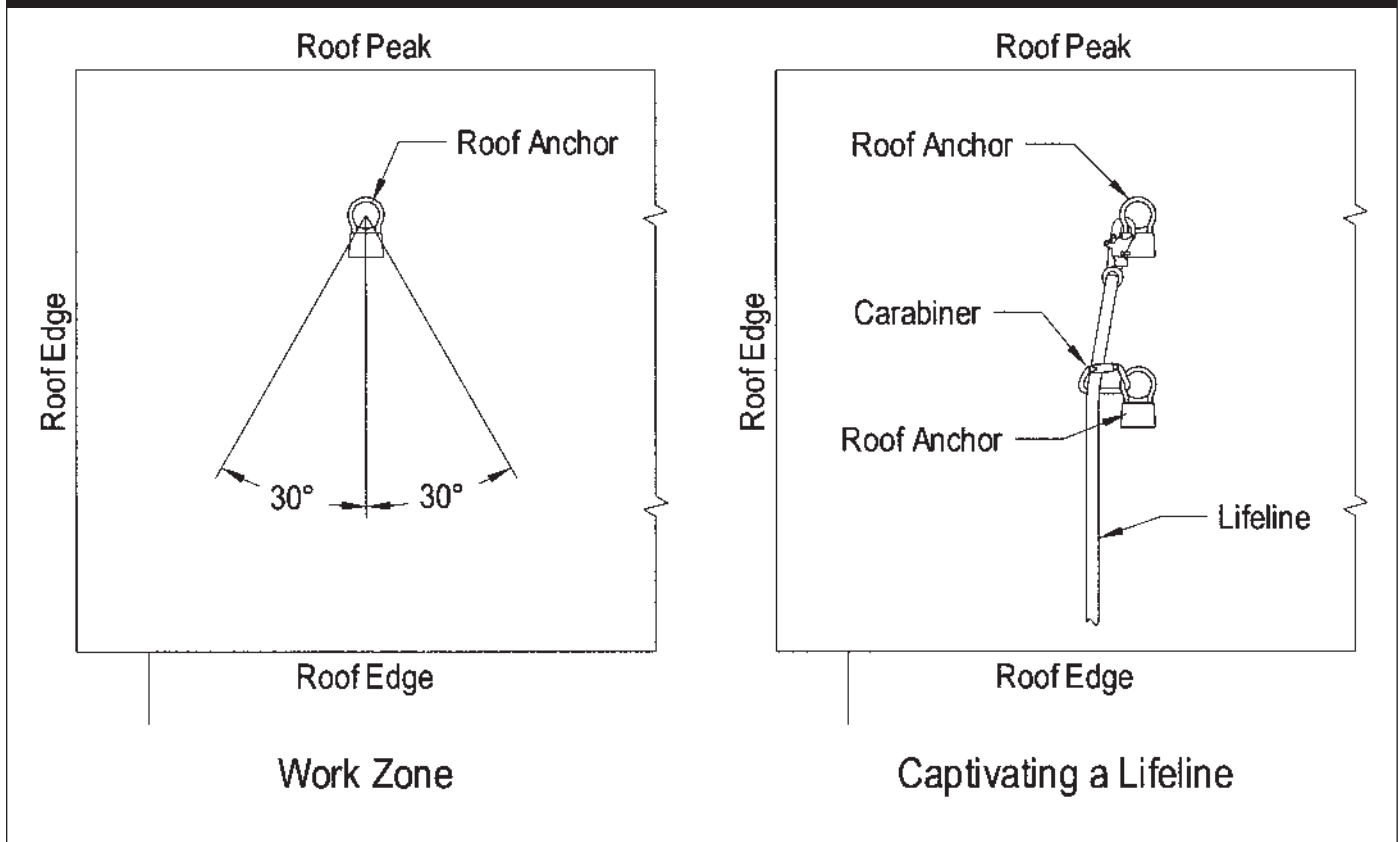


Figure 5 - Work Zone



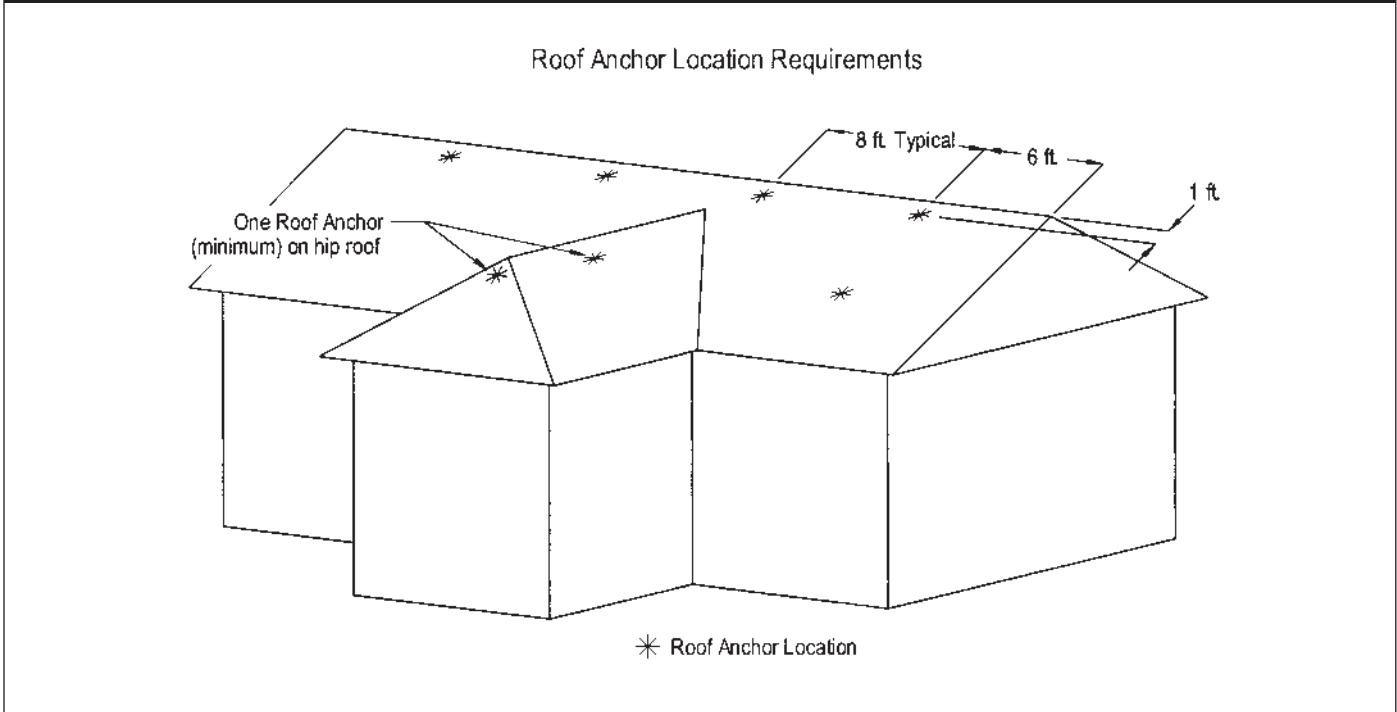
the anchorage point. It is acceptable to captivate a lifeline to an anchorage close to the work area with a carabiner. Do not captivate the lifeline of a self retracting lifeline.

- F. **FALL CLEARANCE:** Ensure sufficient clearance exists in your fall path to prevent striking an object. The clearance required is dependent upon the connecting subsystem (energy absorbing lanyard or self retracting lifeline). See connecting subsystem manufacturer's instructions for fall clearance requirements.
- G. **SHARP EDGES:** Avoid working where your lifeline will be in contact with, or abrade against, unprotected sharp edges.
- H. **RESCUE:** The employer must have a rescue plan and the ability to implement it.
- I. **AFTER A FALL:** Components which have been subjected to fall arrest forces must be removed from service and destroyed.
- J. **GENERAL USE CONSIDERATIONS:** Avoid working where your lifeline may cross or tangle with that of another worker. Do not allow your lifeline to pass under your arms or between your feet.

### 3.3 INSTALLATION REQUIREMENTS:

- A. **ROOF ANCHOR SITE PLAN:** See Figure 6. Before starting construction of the roof, establish a site plan for locations of the roof anchors. Following are guidelines to be used when locating roof anchors:
  - Roof anchors must be located at least 12 inches below the roof peak, measured along the roof surface, and at least six feet from any exposed roof edge. On small roof areas, locate the roof anchor as far from the roof edge as possible.
  - Install the site label in a visible location near the system access point.
  - Do not install roof anchors on unsupported roof structures, such as eaves or gable overhangs.
  - Do not install roof anchors on fascia boards.

**Figure 6 - Roof Anchor Site Plan**



- Install roof anchors at eight feet intervals along the roof peak.
- Hip roofs require a roof anchor on each hip face.
- On long, low pitched roofs, multiple roof anchors should be installed along the gable ends (six feet from the edge) to reduce swing fall hazards.

**B. ROOF FRAMING:**

- Roof members to which the roof anchors are attached must be in good condition. Roof members must be free of splits, cracks, large knots, or other defects that may weaken the roof member. Roof anchors must be located at least six inches away from knots that exceed one inch diameter. The roof members must be capable of supporting the loads specified in section 2.3.

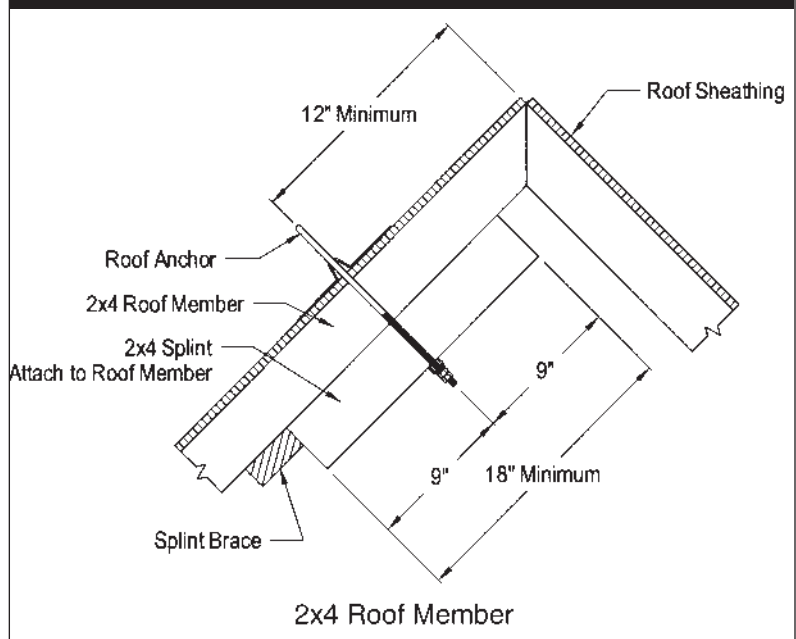
- When installing a roof anchor to a 2 x 4 roof member, the roof member must be reinforced with a 2 x 4 splint at least 18 inches long. See Figure 7. The splint must be fixed in place with a brace to prevent movement along the roof member.

- If roof anchors are intended to be used before the roof sheathing is installed, the roof member must be adequately braced. See Figure 8 for one method of bracing the roof members.

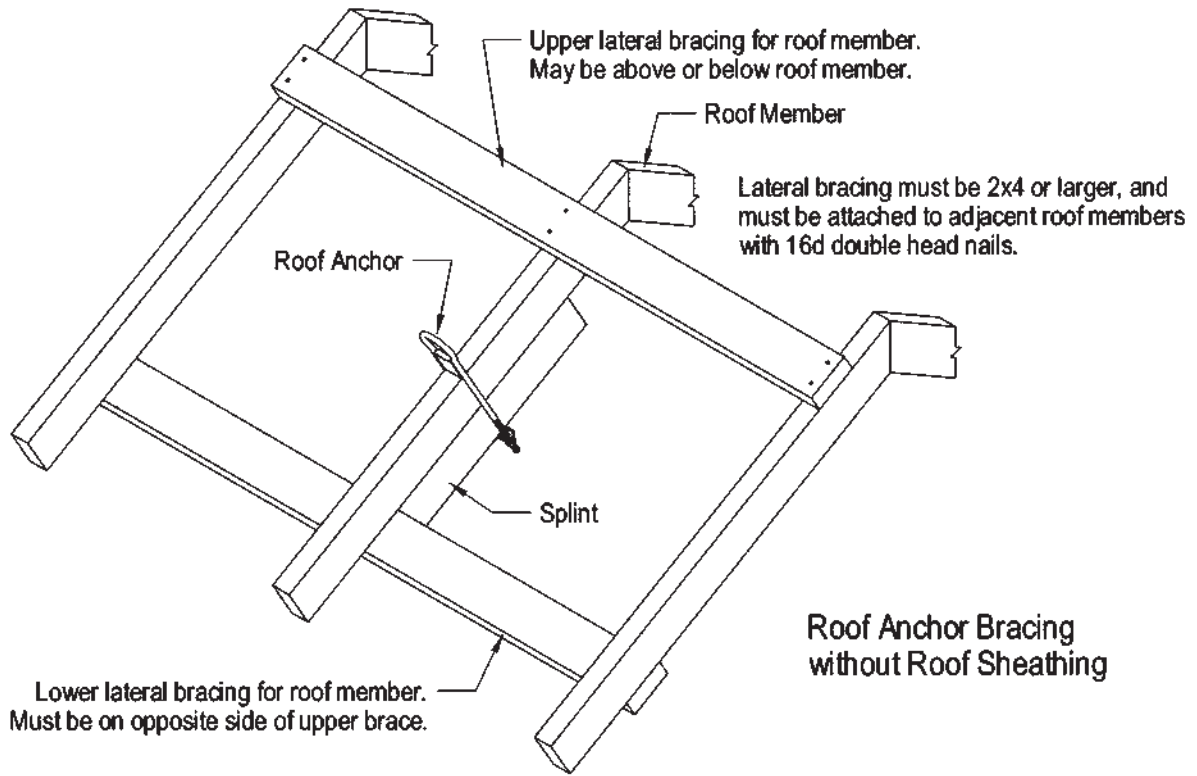
**C. ROOF ANCHOR INSTALLATION:**

Establish the roof anchor site plan as specified in section 3.3. A. At times, during new construction, it is possible to install the roof anchors onto the roof members before they are put into place, allowing use of the roof anchors during much of the roofing process.

**Figure 7 - Roof Anchor Installation**



**Figure 8 - Bracing**

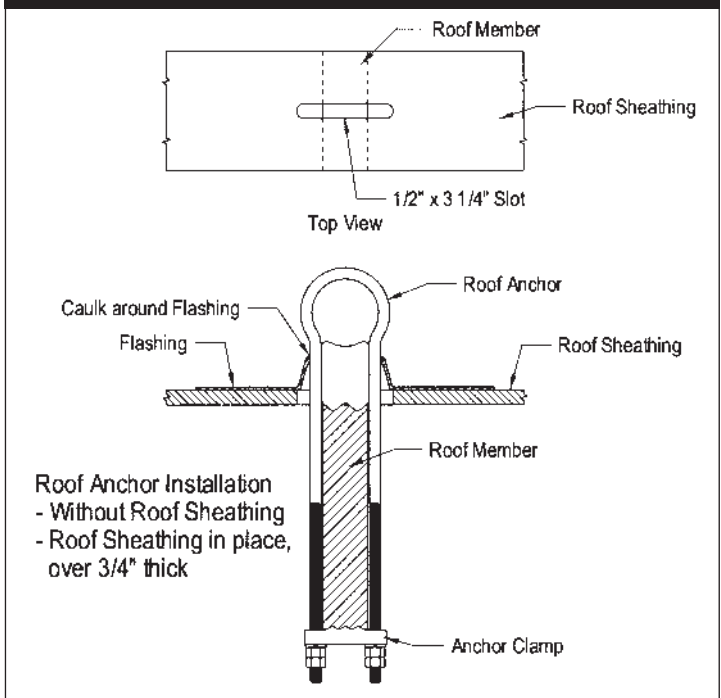


- **To install the roof anchor onto a roof member without roof sheathing:** See Figure 9. Slide

the U-bolt legs over the roof member with the attachment ring on the roof surface side. Install the anchor clamp, lock washers, and nuts onto the U-bolt legs. Tighten the inside nuts down to embed the teeth into the roof member. The teeth may not fully embed into the roof member. Do not overtighten. Lock the roof anchor in place by tightening the outside nuts. Cut a 1/2 x 3 1/4-inch slot in the roof sheathing centered over the roof member at the roof anchor location.

- **To install the roof anchor onto a roof member with roof sheathing in place:** See Figure 9 or 10. Access to the underside of the roof sheathing is required. Remove any roof covering (shingles, felt, etc.) where the roof anchor is to be installed. If the roof sheathing is 3/4-inch thick or more, cut a 1/2 x 3 1/4-inch slot in the roof sheathing centered over the roof member at the roof anchor location. See Figure 9. If the roof sheathing is less than 3/4-inch, install the roof anchor by drilling two 1/2-inch diameter holes through the sheathing, straddling the roof member. See Figure 10. Do not drill through or damage the roof member. Insert the U-bolt legs into the drilled holes or slot. Install the anchor clamp, lock washers, and nuts onto the U-bolt legs. Tighten the inside nuts down to embed the teeth into the roof member. The teeth may not fully embed into the roof member and roof sheathing. Do not overtighten. Lock the roof anchor in place by tightening the outside nuts.

**Figure 9 - Roof Anchor Installation**



- **To install flashing:** Carefully slide the flashing over the attachment ring of the roof anchor. The flashing may be stiff in cold weather, use caution when installing to prevent tearing of the flashing. Shingle over the top of the flashing. Caulk around the flashing as shown in Figures 9 and 10.

- **To install the cap:** After the roof anchor is installed, slide the cap onto the roof anchor, making sure the cable tie ring on the cap is facing the hole in the flashing. See Figure 11. The cap should fit securely around the flashing flange. Attach the cable tie through the hole in the flashing and the cable tie ring on the cap. Leave enough slack in the cable tie to allow the cap to be removed from the anchor.

- Although the U-bolt roof anchor is typically designed for use on a wood frame structure, the anchor can also be imbedded into concrete and used as a permanent anchorage point. The concrete must support the anchorage strength requirements specified in section 2.3. See Figure 12.

**D. PAINTING:** The exposed roof anchor may be painted to match the roof color.

**E. SITE LABEL:** Install the site label in a permanent and prominent location.

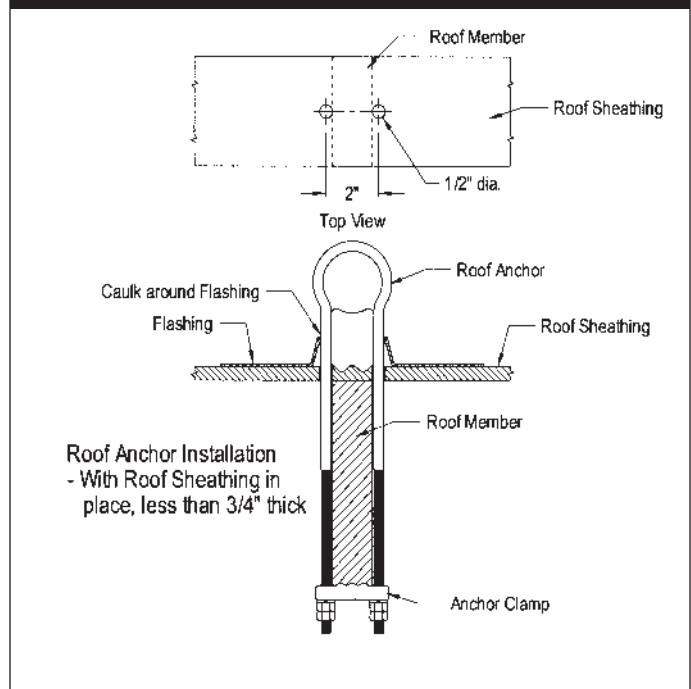
**3.4 CONNECTING TO THE ROOF ANCHOR:** Connect to the roof anchor with a self locking hook or carabiner only. Do not use a knot to connect a lifeline or lanyard to the roof anchor. Ensure all connections are fully closed and locked. See Figure 13 for proper connection of typical fall arrest or restraint equipment to the roof anchor. When using an energy absorbing lanyard, connect the energy absorber pack end to your harness. When using a self retracting lifeline, ensure the device positioned so that the retraction is not hindered. Do not allow the lanyard or lifeline to abrade against unprotected sharp edges or surfaces. Ensure all connections are compatible in size, shape, and strength. Do not connect more than one lanyard or lifeline to a single roof anchor member.

## 4.0 TRAINING

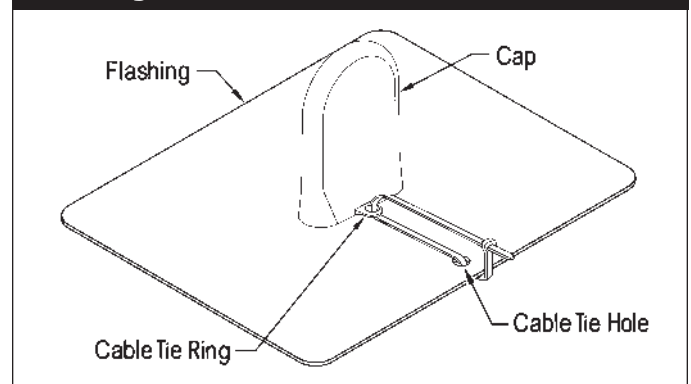
**4.1 TRAINING:** The user and the user's employer, must be trained in the correct use and care of this equipment. Both parties must be aware of the operating characteristics, application limits, and the consequences of improper use of this equipment.

**IMPORTANT:** Training must be conducted without exposing the trainee to a fall hazard. Training should be repeated on a periodic basis.

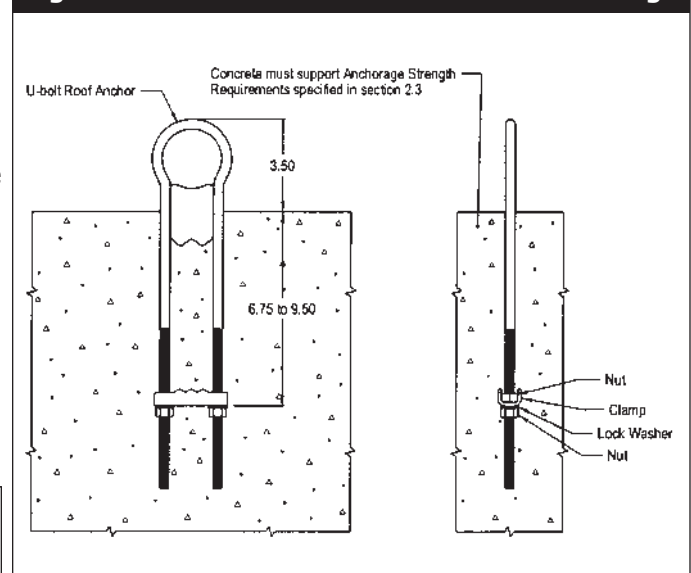
**Figure 10 - Roof Anchor Installation**



**Figure 11 - Roof Anchor Installation**

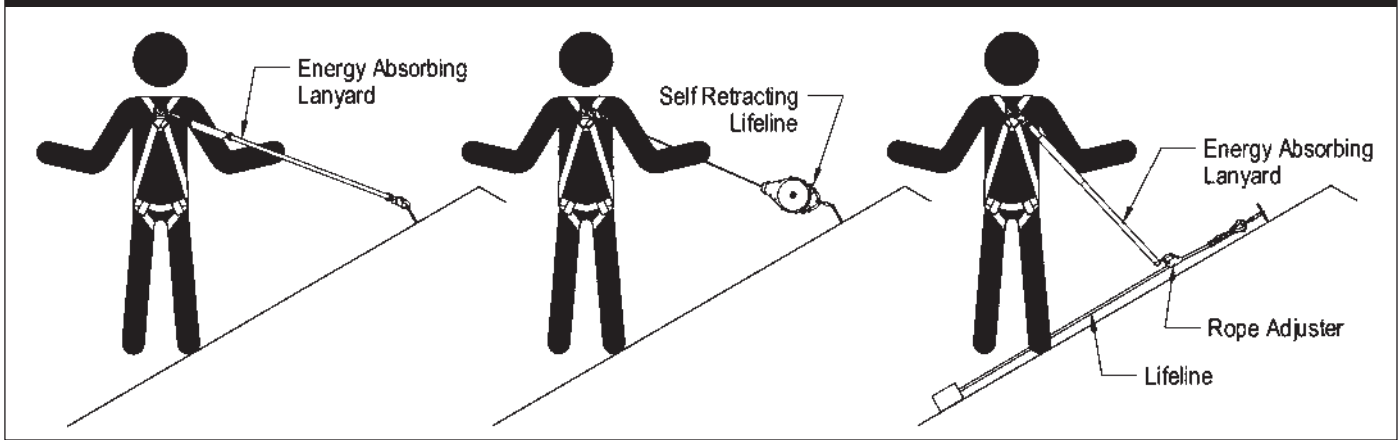


**Figure 12 - Installation into Concrete Anchorage**





**Figure 13 - Making Connections**



## **5.0 INSPECTION**

### **5.1 FREQUENCY:**

- **Before Each Use** inspect according to steps listed in section 5.2.
- **This Equipment** must be inspected according to steps listed in section 5.2 by a competent person, other than the user, at least annually. Record the results of each inspection in the inspection and maintenance log in section 9.0.

**WARNING:** If this equipment has been subjected to fall arrest forces remove from service and destroy.

**IMPORTANT:** Extreme working conditions (harsh environments, prolonged use, etc.) may require increasing the frequency of inspections

### **5.2 INSPECTION STEPS:**

- Step 1.** Inspect roof anchor for cracks, dents, bends, corrosion, or deformities. The roof anchor must be perpendicular to the roof surface.
  - Step 2.** Inspect roof condition. The roof must support the required roof anchor loads. Do not use a roof anchor connected to deteriorated wood.
  - Step 3.** Ensure roof anchor is securely attached to the roof member. Tighten roof anchors as required.
  - Step 4.** Inspect flashing and caulking for deterioration or leakage.
  - Step 5.** Labels must be present and fully legible. Replace any missing or illegible labels.
  - Step 6.** Inspect each system component and subsystem according to manufacturer's instructions.
  - Step 7.** Record the inspection date and results in the inspection and maintenance log in section 9.0.
- 5.3** If inspection reveals an unsafe or defective condition, remove roof anchor from service and destroy, or contact an authorized service center for repair.

**NOTE:** Only DBI/SALA or an authorized service center may make repairs to this equipment.

## 6.0 MAINTENANCE AND SERVICING

- 6.1** No scheduled maintenance is required for this equipment. If you have questions about the condition of your roof anchor, contact DBI/SALA.
- 6.2** All maintenance and servicing must be completed by an authorized service center.

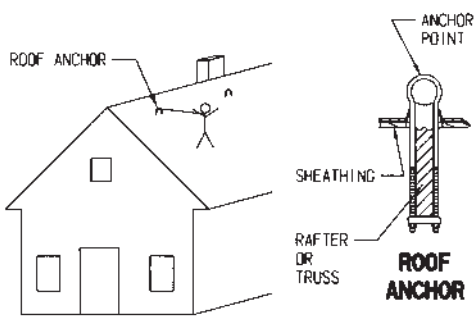
## 7.0 SPECIFICATIONS

**MATERIAL:** Stainless steel  
**MINIMUM BREAKING STRENGTH:** 5,000 lbs.  
**WEIGHT:** 2103670: 1.5 lbs.; 2103671: 1.75 lbs.  
**SIZE:** 2103670: 3/8 x 3 x 13.875 inches; 2103671: 3/8 x 3 x 17.75 inches  
**CAPACITY:** 310 lbs., one person

## 8.0 LABELING


- 8.1** The following labels must be present and fully legible:

**2103670 ROOF ANCHOR  
2103671 ROOF ANCHOR**



**▲ WARNING**


Maximum capacity 1 person, 310 lbs. Refer to user instructions for more details. Failure to follow instructions may result in serious injury or death.



DBI/SALA  
3965 PEPIN AVENUE  
RED WING, MN 55066-1037  
(800) 328-6146

This building has 2103670 or 2103671 roof anchors installed near the peak of the roof as shown above. The anchors are connected around rafters, trusses, or joists as shown above. These anchors are designed for use with ANSI/OSHA personal fall arrest systems. Do not attach horizontal lines or other devices to the anchor. Do not remove this label.

MADE IN USA



MADE IN USA

DBI/SALA; 3965 Pepin Ave.  
Red Wing, MN 55066, (800) 328-6146

**2103670 ROOF ANCHOR**  
2X4, 2X6, & 2X8 RAFTERS

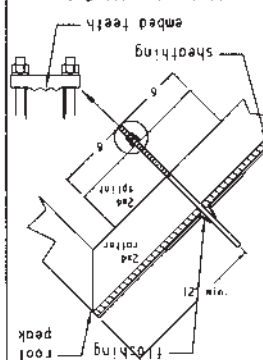
**2103671 ROOF ANCHOR**  
2X10 & 2X12 RAFTERS

**▲ WARNING**

Maximum anchor capacity, 1 person, 310 lbs. Use only with ANSI/OSHA compliant personal fall arrest systems. Read and follow instructions supplied with this anchor. Failure to follow these instructions could result in serious injury or death.

Meets OSHA Requirements.

Use split only with 2x4 rafters. See instructions for more details.



INSTALLATION:

**9.0 INSPECTION AND MAINTENANCE LOG**

DATE OF MANUFACTURE \_\_\_\_\_

MODEL NUMBER \_\_\_\_\_

DATE OF PURCHASE \_\_\_\_\_

INSPECTION DATE	INSPECTION ITEMS NOTED	CORRECTIVE ACTION	MAINTENANCE PERFORMED
Approved by:			
Approved by:			
Approved by:			
Approved by:			
Approved by:			
Approved by:			
Approved by:			
Approved by:			
Approved by:			
Approved by:			
Approved by:			
Approved by:			
Approved by:			
Approved by:			
Approved by:			
Approved by:			
Approved by:			
Approved by:			
Approved by:			
Approved by:			
Approved by:			

This instruction applies to the following models:

2101720  
2103670  
2103671  
2104170  
2104171

Additional model numbers may appear on the next printing of these instructions



**USA**

3833 SALA Way  
Red Wing, MN 55066-5005  
Toll Free: 800-328-6146  
Phone: (651) 388-8282  
Fax: (651) 388-5065  
[www.capitalsafety.com](http://www.capitalsafety.com)

**Canada**

260 Export Boulevard  
Mississauga, Ontario L5S 1Y9  
Toll Free: 800-387-7484  
Phone: (905) 795-9333  
Fax: (905) 795-8777  
[www.capitalsafety.com](http://www.capitalsafety.com)

This instruction manual is available for download at [www.capitalsafety.com](http://www.capitalsafety.com).



Form: 5902113  
Rev: H