

SERIE NARDI

grupoKassandra

ES MODELOS
GB MODEL

FR EXEMPLAIRE
DE MODELL

ESQUEMA/SCHEME/SCHÉMA/SCHEMA

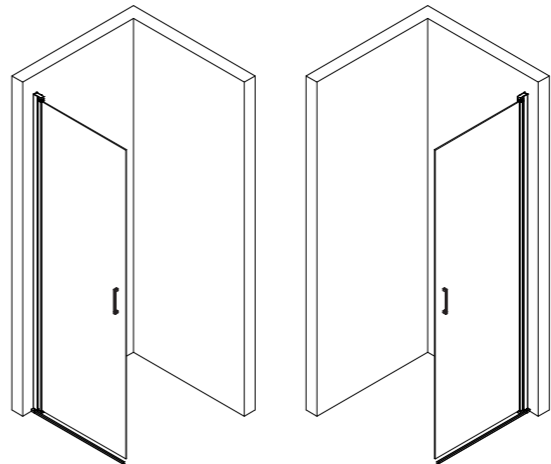
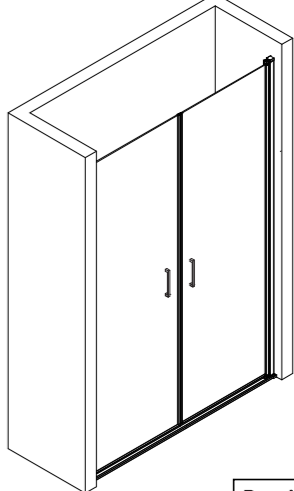
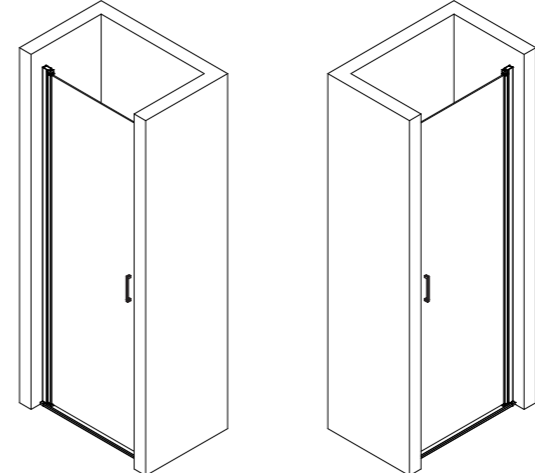
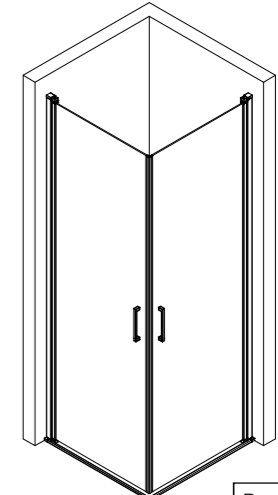
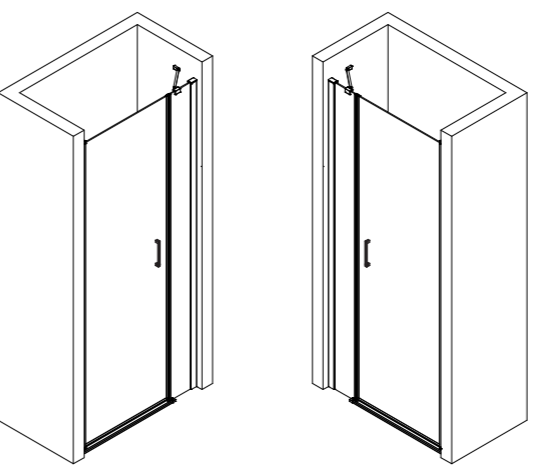
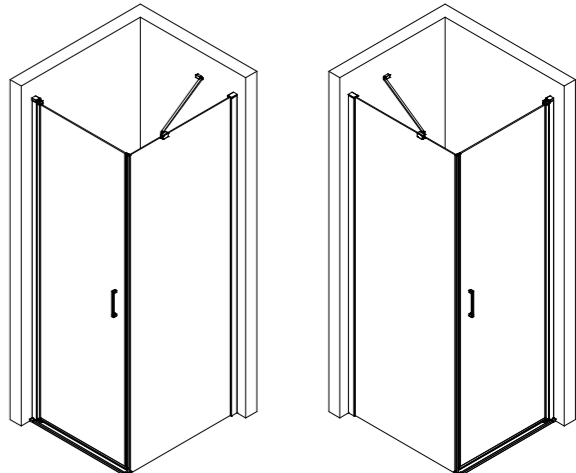
NA 520	NA600+601	NA 501	NA600(2)+601(2)+606
 <p data-bbox="2041 884 2258 911">Paginas 13-14-15</p>		 <p data-bbox="2635 884 2896 911">Paginas 22-23-24-25</p>	
NA 500	NA600+601+602	NA 506	NA600(2)+601(2)+605
 <p data-bbox="2041 1415 2258 1442">Paginas 16-17-18</p>		 <p data-bbox="2635 1415 2896 1442">Paginas 26-27-28-29</p>	
NA 502	NA600+601+613	NA 507	NA600+601+623
 <p data-bbox="2041 1946 2258 1974">Paginas 19-20-21</p>		 <p data-bbox="2665 1946 2896 1974">Paginas 30-31-32</p>	

SERIE NARDI

grupoKassandra

ES MODELOS
GB MODEL

FR EXEMPLAIRE
DE MODELL

ESQUEMA/SCHEME/SCHEMA/SCHEMA

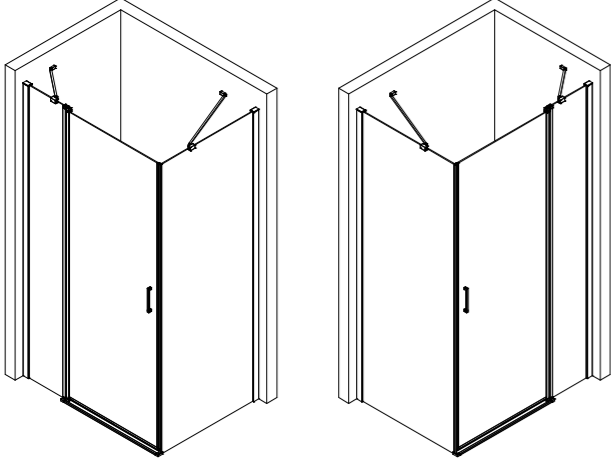
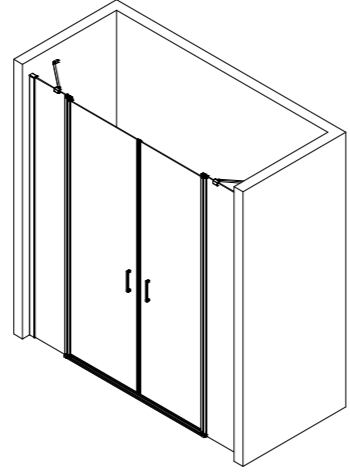
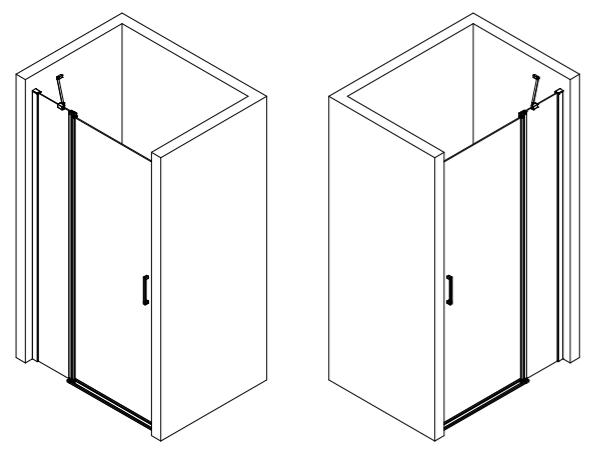
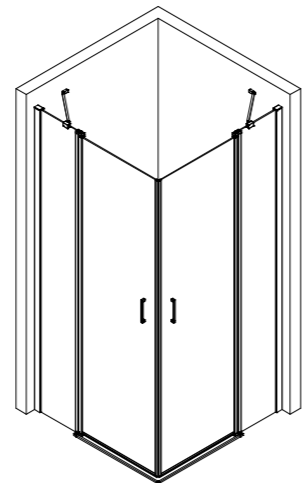
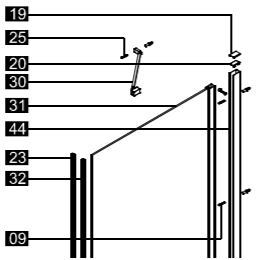
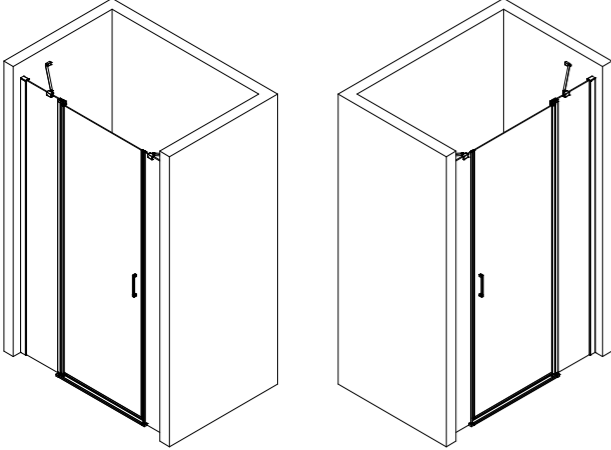
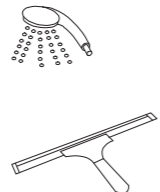
NA 508	NA600+603+623	NA 515	NA600(2)+603(2)+606
 <p data-bbox="445 882 697 913">Paginas 33-34-35-36</p>		 <p data-bbox="1083 882 1335 913">Pagina 43-44-45-46</p>	
NA 503	NA603+600+602	NA 505	NA600(2)+603(2)+605
 <p data-bbox="489 1417 697 1451">Paginas 37-38-39</p>		 <p data-bbox="1083 1417 1335 1451">Pagina 47-48-49-50</p>	
NA 517	NA600+603+613	 <p data-bbox="1009 1533 1246 1606">DESGLOSE DE COMPONENTES</p> <p data-bbox="1023 1680 1335 1717">Pagina 3-4-5-6-7-8-9-10</p>	
 <p data-bbox="489 1953 697 1980">Pagina 40-41-42</p>		 <p data-bbox="964 1785 1231 1858">LIMPIEZA Y MANTENIMIENTO</p> <p data-bbox="1083 1953 1335 1980">Pagina 51-52-53-54</p>	

ART DER REINIGUNG	REINIGUNGS-VERFAHREN	REINIGUNGS-VERFAHREN	REINIGUNGS-VERFAHREN	HÄUFIGKEIT DER REINIGUNG	TRANSPARANTE GLASSCHEIBE	MIT EASY-CLEAN VEREDELTEN GLASOBERFLÄCHEN
ROUTINE-REINIGUNG		Mit klarem Wasser heiß und anschließend kalt abbrausen.	Trocknen mit einem Schaber	Direkt nach dem Duschen	YA	YA
HAUPT REINIGUNG	Mit verdünnter Essigessenz reinigen 	Mit klarem Wasser abspülen	Trocknen mit einem Schaber	Je nach Benutzungshäufigkeit bzw. Bedarf wöchentlich oder monatlich	YA	YA
INTENSIVE REINIGUNG	Im trockenen Zustand mit Polierpaste polieren. 	Mit klarem Wasser abspülen	Trocknen mit einem Schaber	Erforderlich bei starker Verschmutzung und Bildung von Kalk- und Mineralschleim. Wenn längere Zeit nicht gereinigt wurde	YA	NIE

DIE RICHTIGE REINIGUNG IST WICHTIG.

Ihre Duschkabine ist auf minimierten Reinigungsaufwand konstruiert. Damit sich Ihre Duschkabine lange glänzend hält, sollten Sie dennoch einige Regeln beachten: Profile und Scheiben dürfen nur mit milden, handelsüblichen Pflegemitteln (keine Microfasertücher und oder kratzende Lappen) gesäubert werden. Auf keinen Fall Putz- oder Scheuermittel, Alkohol, Nitroverdünnung etc. verwenden. Wasser hat einen unterschiedlich hohen Anteil an Kalk, der nach dem Verdunsten der Wassertropfen auf der Oberfläche zurück bleibt und Flecken hinterlässt, daher empfehlen wir, Ihre Duschkabine eine häufige Reinigung. Denn je älter die Ablagerungen, desto schwerer sind sie zu entfernen.

WARTUNG DER MECHANISCHEN TEILE.

Auch die mechanischen Teile der Duschkabine benötigen etwas Pflege, um ihre reibungslose Funktion über viele Jahre zu erhalten. Dazu empfiehlt es sich, einmal jährlich Führungsschienen, Laufrollen und Gelenke z. B. mit Vaseline oder Silikonspray zu schmieren sowie die Schrauben von Laufrollen und Metallbeschlägen nachzuziehen.

DIE EASY-CLEAN-BESCHICHTUNG.

EASY-CLEAN ist eine Spezialbehandlung, bei der das Glas eine extra Glatte Oberflächenbeschichtung erhält. Diese verhindert, dass sich angetrocknete Wassertropfen, Seifenreste, Schmutz- und Kalkspuren hartnäckig festsetzen. Das Reinigen bleibt dadurch nicht erspart, aber es löst sich alles viel leichter und deutlich weniger anstrengend. Zur Reinigung der mit EASY-CLEAN veredelten Glasoberflächen empfehlen wir: Weiche, nicht scheuernde Lappen und Handelsübliche, nicht scheuernde Reinigungsmittel.

ES DESGLOSE DE COMPONENTES
GB BREAKDOWN OF COMPONENTS

FR COMPOSANTS DE VENTILATION
DE AUFSCHLÜSSELUNG DER KOMPONENTEN

ESQUEMA/SCHEME/SCHÉMA/SCHEMA

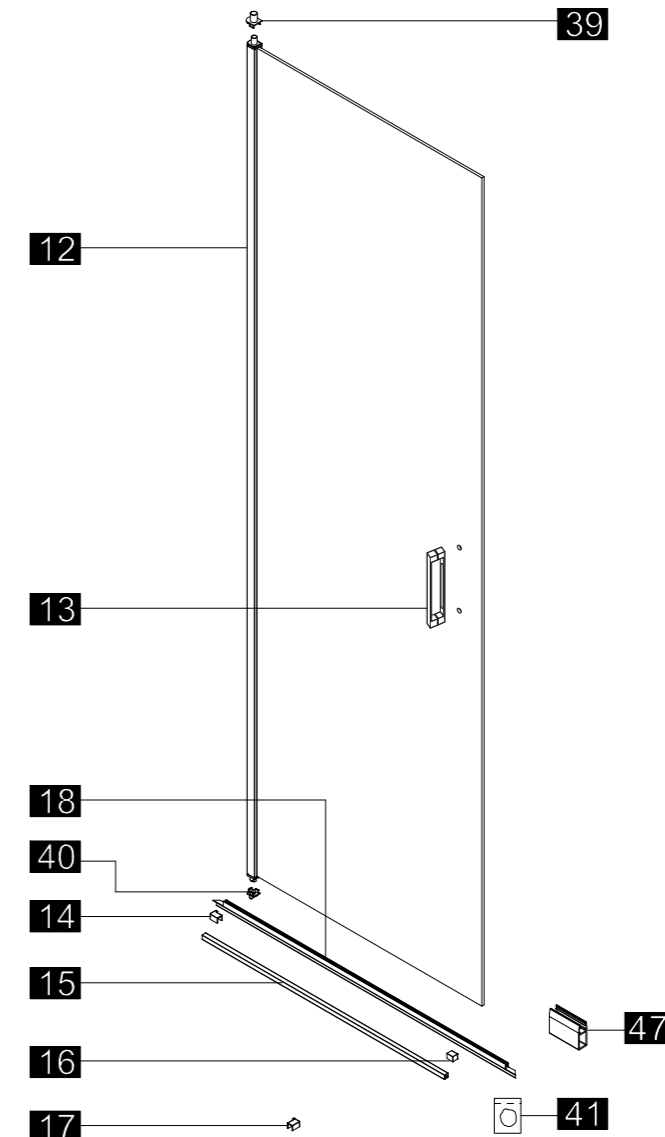

Nº	DIBUJO	CODIGO	DESCRIPCION	UNIDADES	UDS/MAMPARA
12			Puerta Door Porte Tür	Uds	1
13		22MNAPTIRS001012	Tirador Handle Poignée Türgriff	Uds	1
14		22MNATERM001012	Terminal perfil de retencion pequeno izq Terminal Retention profile small left La rétention des bornes gauche petit profil Terminal Retention Profil kleine linke	Uds	1
15		33RNARE10	Perfil de retención Bottom track Profilé rétention Abdichtungsprofil	Uds	1
16		22MNATERMS002012	Terminal perfil de retencion recto Terminal Retention profile straight La rétention des bornes droites profil Terminal Retention Profil gerade	Uds	1
17		22MNATERMD001012	Terminal perfil de retencion pequeno izq Terminal Retention profile small right Profil de rétention Terminal petite droite Terminal Retention Profil kleine rechts	Uds	1

Nº	DIBUJO	CODIGO	DESCRIPCION	UNIDADES	UDS/MAMPARA
18		33RNAVA10	Goma vierteaguas Rubber rain channel Gouttière en caoutchouc Gummi wasserablauffrinne	Uds	1
39		22MNALEVAS001012	Leva superior Upper cam La came supérieure Obere cam	Uds	1
40		22MNALEVAS002012	Leva inferior Lower Cam Came inférieur Unteren Cam	Uds	1
41		22MNAVASES001000	Vaselina Vaseline Vaseline Vaselin	Uds	1
47		22MNCALZS001000	Calzo hoja abatible Folding sheet chock Feuille pliante caler Fälzbogen Keil	Uds	1

ES DESGLOSE DE COMPONENTES
GB BREAKDOWN OF COMPONENTS

FR COMPOSANTS DE VENTILATION
DE AUFSCHLÜSSELUNG DER KOMPONENTEN

ESQUEMA/SCHEME/SCHEMA/SCHEMA

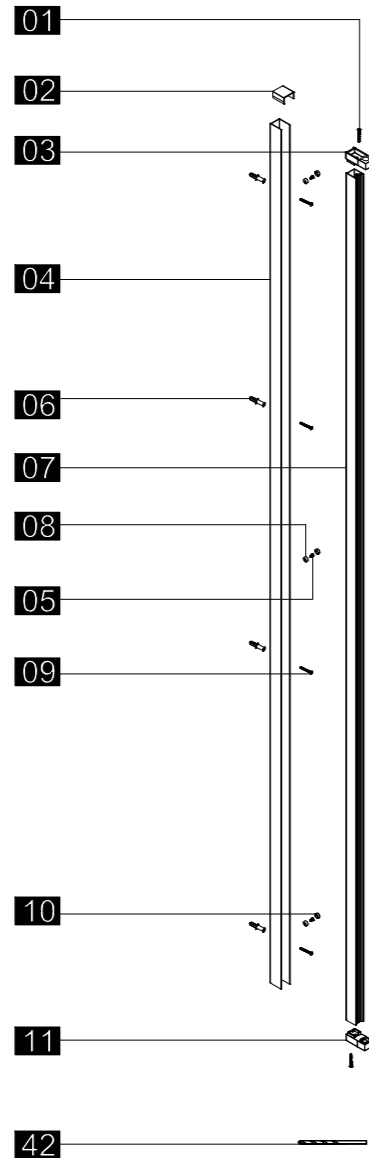

Nº	DIBUJO	CODIGO	DESCRIPCION	UNIDADES	UDS/ MAMPARA
01		22MAATORNS535035	Tornillos ST3.5x35 Screw ST3.5x35 Vis ST3.5x35 Schraube ST3.5x35	Uds	2
02		22MNATAPES001012	Tapa conjunto de giro Cover pan Couvrir le moule Abdeckung pan	Uds	1
03		22NALEVAS003012	Soporte conjunto de giro superior Top swivel joint support Joint support pivotant haut Top Drehgelenk Unterstützung	Uds	1
04		33PNACO161950AAA	Compensador cerco lateral Side fence compensator Balance de clôture côté Seitenanschlag kompensator	Uds	1
05		22MAATORNS539010	Tornillos ST4x10 Screw ST4x10 Vis ST4x10 Schraube ST4x10	Uds	3
06		22MAATACOS001006	Taco S-6 Rawlplug S-6 Chevilles S-6 Dübel S-6	Uds	4

Nº	DIBUJO	CODIGO	DESCRIPCION	UNIDADES	UDS/ MAMPARA
07		33PNAACL161924AAA	Cerco lateral Fence side Côté clôture Zaun seite	Uds	1
08		22MNATAPOS001012	Tapa tornillo Cap Screw La vis Sechskantschraube	Uds	3
09		22MAATORNS539035	Tornillos ST4x35 Screw ST4x35 Vis ST4x35 Schraube ST4x35	Uds	4
11		22MNALAVAS004012	Soporte conjunto de giro inferior Joint support lower turn Joint support tour inférieur Gemeinsame Unterstützung Drehen	Uds	1
42		55CAABRWIS000320	Broca D:3.2 Bit D:3.2 Foret D:3.2 Steinbohrer D:3.2	Uds	1

FR

NETTOYAGE ET ENTRETIEN CORRECT DE VOTRE PARE-DOUCHE

TYPE DE NETTOYAGE	PROCÉDÉ	PROCÉDÉ	PROCÉDÉ	FRÉQUENCE DES NETTOYAGES	VITRE TRANSPARANTE	VITRE AVEC TRATAMIENTO EASY-CLEAN
NETTOYAGE QUOTIDIEN		Rincer à l'eau chaude et ensuite à l'eau froide	Sécher en passant une raclette	immédiatement après votre douche	OUI	OUI
NETTOYAGE PRINCIPAL	Nettoyer à l'aide d'un mélange d'eau chaude et de vinaigre	Rincer à l'eau claire	Sécher en passant une raclette	Hebdomadaire ou mensuel. Selon les préférences de l'utilisateur	OUI	OUI
NETTOYAGE INTENSIF	polir à sec avec de la pâte à polir	Rincer à l'eau claire	Sécher en passant une raclette	En cas de formation de salissures solides et de taches de calcaire. Quand le nettoyage n'a pas été fait pendant un grand laps de temps.	OUI	JAMAIS

IMPORTANT POUR UN NETTOYAGE CORRECT.

Votre pare-douche a été fabriqué pour un minimum d'effort de nettoyage. Pour que votre pare-douche soit maintenu inaltéré et reluisant de façon durable, certaines normes devraient être respectées: Pour le nettoyage des profilés et des vitres, veuillez utiliser uniquement des produits doux, ne pas utiliser de produit de nettoyage, type abrasif, alcool ou Acide nitrique. Pour le nettoyage ne jamais utiliser d'éléments abrasifs comme peuvent l'être certains chiffons rugueux microfibre et certaines éponges à laine d'acier, cela peut causer des rayures irréparables. Le calcaire dans l'eau produit des taches, ce qui rend nécessaire un nettoyage fréquent et régulier pour préserver la propreté de votre pare-douche. Plus on tardera à nettoyer les traces de calcaire, plus ce sera difficile de les enlever.

ENTRETIEN DES PIÈZES MÉCANIQUES

Les pièces mécaniques dans le pare-douche ont besoin aussi d'un peu d'entretien pour en garantir le parfait fonctionnement plusieurs années. Les roulements et les parties articulées du pare-douche doivent être légèrement lubrifiés. De plus, les vis qui restent visibles, doivent être serrées.

REVÊTEMENT EASY-CLEAN.

Le revêtement EASY-CLEAN est un traitement spécial qui ajoute une couche superficielle ultra-lisse assurant la protection permanente contre des gouttes d'eau, des restes de savon, de salissure ou de calcaires. Le nettoyage n'est pas évitée, mais on réussit à éliminer toute trace de résidus de façon simple et sans trop d'effort. Pour le nettoyage de surfaces de verre revêtues d'un traitement EASY-CLEAN, on doit utiliser des chiffons doux et un produit de nettoyage non abrasif.

GB

PROPER CLEANING AND MAINTENANCE OF YOUR SCREEN

CLEANING TYPE	PROCEDURE	PROCEDURE	PROCEDURE	CLEANING INTERVAL	TRANSPARENT GLASS	GLASS WITH EASY-CLEAN TREATMENT
ROUTINE CLEANING		First pour clean hot water and pour cold water afterwards 	Dry with a squeegee 	Immediately after every shower	YES	YES
MAIN CLEANING	Clean with water and diluted vinegar 	Rinse with clean water 	Dry with a squeegee 	Weekly or monthly, according to user preferences	YES	YES
INTENSIVE CLEANING	Dry polish with polishing paste 	Rinse with clean water 	Dry with a squeegee 	In case of formation of solid dirt and limescale stains. When it has not been cleaned in a longer period of time	YES	NEVER

IMPORTANT FOR A PROPER CLEAN.

Your shower screen has been -easy-to-clean- designed . Some rules must be taken into account to keep your screen sparkling clean for a very long time: profiles and glasses may only be cleaned with a smooth product, abrasive cleaners such as alcohol or nitric solutions should not be used. Steel wool or rough microfiber cloths should not be used either because they may cause scratches. Lime scale present in water produces spots. This is why frequent cleaning is crucial to keep it clean always; the longer lime scale rests stay , the harder it will be to remove them later.

MAINTENANCE OF MECHANICAL PARTS

The mechanical parts of your shower screen also need some maintenance to keep them in good working order for many years. Both the screen bearings and their articulated parts must be slightly lubricated. The visible screws must be tightened.

EASY-CLEAN COVER

EASY-CLEAN cover is a special treatment that gives your glass an extra-flat superficial layer. It prevents the lingering accession of water droplets, soap scum or lime scale. It does not keep you from cleaning your screen but rather eliminates the dirt easy and effortlessly. To clean the glass surface covered with EASY CLEAN treatment, nonabrasive cloths and nonabrasive cleaning agents must be used

ES DESGLOSE DE COMPONENTES
GB BREAKDOWN OF COMPONENTS

FR COMPOSANTS DE VENTILATION
DE AUFSCHLÜSSELUNG DER KOMPONENTEN

ESQUEMA/SCHEME/SCHÉMA/SCHEMA

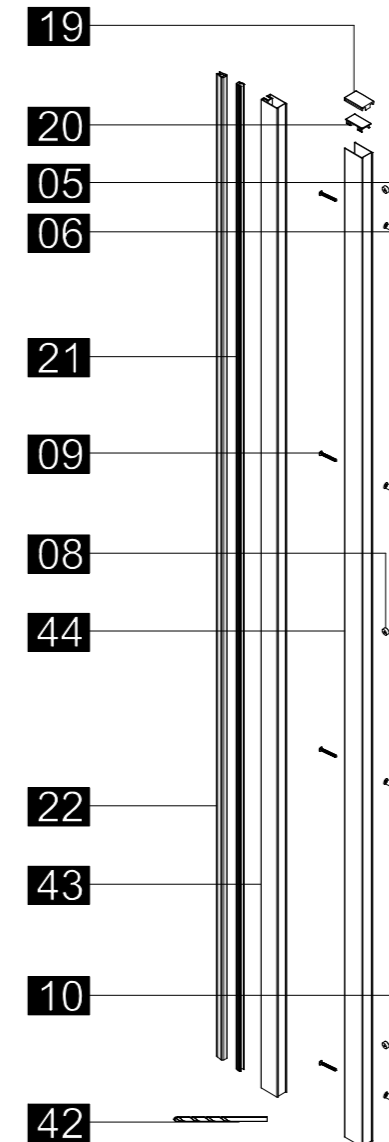

Nº	DIBUJO	CODIGO	DESCRIPCION	UNIDADES	UDS/MAMPARA
05		22MAATORNS539010	Tornillos ST4x10 Screw ST4x10 Vis ST4x10 Schraube ST4x10	Uds	3
06		22MAATACOS001006	Taco S-6 Rawplug S-6 Chevilles S-6 Dübel S-6	Uds	4
08		22MNATAPOS001012	Tapa tornillo Cap Screw La vis Sechskantschraube	Uds	3
09		22MAATORNS539035	Tornillos ST4x35 Screw ST4x35 Vis ST4x35 Schraube ST4x35	Uds	4
19		22MNATAPES002012	Tapa de compensador perfil de cierre Cap compensator close profile Profil de compensateur de la pac Cap kompensator schliessen profil	Uds	1

Nº	DIBUJO	CODIGO	DESCRIPCION	UNIDADES	UDS/MAMPARA
20		22MNATAPES003012	Tapa perfil de cierre Lid close profile Couvercle profil fermer Deckel schließen profil	Uds	1
21		33RNAMP101925AAA	Iman perfil de cierre Magnet close profile Profil aimant Magnet profil	Uds	1
22		33RNAMP101925AAA	Iman frontal Front magnet L'aimant avant Der magnet	Uds	1
42		55CAABRWIS000320	Broca D:3.2 Bit D:3.2 Foret D:3.2 Steinbohrer D:3.2	Uds	1
43		33PNACR161925AAA	Perfil de cierre Close profile Profil fermer Schließen profil	Uds	1
44		33PNACC161925AAA	Compensador perfil de cierre Compensator close profile Profil de compensateur Kompensator schließen profil	Uds	1

ES DESGLOSE DE COMPONENTES
GB BREAKDOWN OF COMPONENTS

FR COMPOSANTS DE VENTILATION
DE AUFSCHLÜSSELUNG DER KOMPONENTEN

ESQUEMA/SCHEME/SCHEMA/SCHEMA

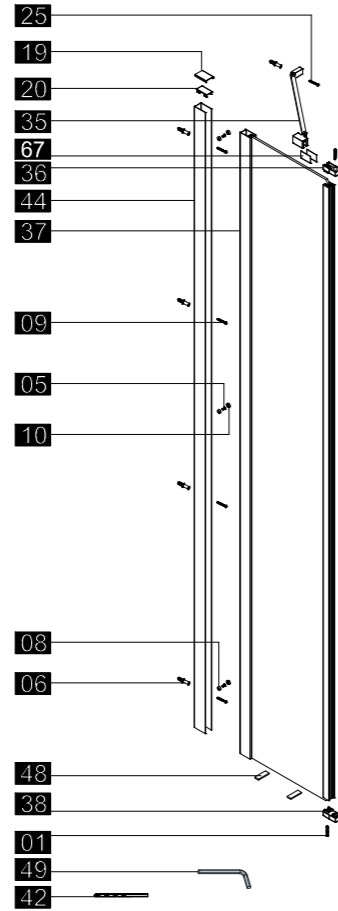

Nº	DIBUJO	CODIGO	DESCRIPCION	UNIDADES	UDS/ MAMPARA
01		22MAATORNS535035	Tornillos ST3.5x35 Screw ST3.5x35 Vis ST3.5x35 Schraube ST3.5x35	Uds	2
05		22MAATORNS539010	Tornillos ST4x10 Screw ST4x10 Vis ST4x10 Schraube ST4x10	Uds	3
06		22MAATACOS001006	Taco S-6 Rawplug S-6 Chevilles S-6 Dübel S-6	Uds	5
08		22MNATAPOS001012	Tapa tornillo Cap Screw La vis Sechskantschraube	Uds	3
09		22MAATORNS539035	Tornillos ST4x35 Screw ST4x35 Vis ST4x35 Schraube ST4x35	Uds	4
19		22MNATAPE002012	Tapa de compensador perfil de cierre Cap compensator close profile Profil de compensateur de la pac Cap compensator schliessen profil	Uds	1
20		22MNATAPE003012	Tapa perfil de cierre Lid close profile Couvercle profil fermer Deckel schließen profil	Uds	1
25		22MAATORNS440035	Tornillos ST4x35 Screw ST4x35 Vis ST4x35 Schraube ST4x35	Uds	1

Nº	DIBUJO	CODIGO	DESCRIPCION	UNIDADES	UDS/ MAMPARA
35		22MNBRAZ001012 22MNBRAZ002012 22MNBRAZ003012 22MNBRAZ004012 22MNBRAZ005012	Brazo articulado Articulated arm Bras articulé Gelenkarm	Uds	1
36		22MNALVAS005012	Soporte conjunto de giro superior Top swivel joint support Joint support pivotant haut Top Drehgelenk Unterstützung	Uds	1
37			Fijo fixed fixe festgelegt	Uds	1
38		22MNALVAS006012	Soporte conjunto de giro inferior Joint support lower turn Joint support tour inférieur Gemeinsame Unterstützung Drehen	Uds	1
42		55CAABRWIS000320	Broca D:3.2 Bit D:3.2 Foret D:3.2 Steinbohred D:3.2	Uds	1
44		33PNACC161925AAA	Compensador perfil de cierre Compensator close profile Profil de compensateur Kompensator schließen profil	Uds	1
48		22MADCALZ015010	Calzo hoja fija Chock fixed blade Caler la lame fixe Keil mit fester Klinge	Uds	2
49		55UAALLALS001002	Llave allen de 2mm Allen wrench of 2mm Clé Allen 2mm Inbusschlüssel 2mm	Uds	1
67		22MNAJUNTS002000	Junta barra Board Bar Bar conseil Board Bar	Uds	2

ES

LIMPIEZA Y CORRECTO MANTENIMIENTO DE SU MAMPARA

TIPO DE LIMPIEZA	PROCEDIMIENTO	PROCEDIMIENTO	PROCEDIMIENTO	INTERVALO DE LIMPIEZA	CRISTAL TRANSPARENTE	CRISTAL CON TRATAMIENTO EASY-CLEAN
LIMPIEZA RUTINARIA		Echar agua clara caliente y luego fría 	Secar con rasqueta 	inmediatamente después de la ducha	SI	SI
LIMPIEZA PRINCIPAL	Limpia con agua y vinagre diluido 	Aclarar con agua limpia 	Secar con rasqueta 	Semanal o mensual, según preferencias del usuario	SI	SI
LIMPIEZA INTENSIVA	Pulir en seco con pasta de pulido 	Aclarar con agua limpia 	Secar con rasqueta 	En caso de formación de suciedad sólida y manchas de cal. Cuando no se haya limpiado en un intervalo mas grande de tiempo	SI	NUNCA

IMPORTANTE PARA UNA LIMPIEZA CORRECTA.

Su mampara está fabricada para un esfuerzo mínimo de limpieza. Para que su mampara se mantenga reluciente de forma duradera se deben respetar algunas normas: los perfiles y los vidrios solo se pueden limpiar con productos de limpieza ligeros, no se debe utilizar productos de limpieza abrasivos, alcohol o soluciones nítricas. Para la limpieza tampoco se deben utilizar estropajos de acero o paños bastos de microfibras ya que aparecerían arañazos. La cal presente en el agua produce manchas por lo que una limpieza frecuente es decisiva para mantener su mampara limpia, cuanto más tiempo lleven los restos de cal, más difíciles serán de quitar.

MANTENIMIENTO DE PIEZAS MECANICAS.

Las piezas mecánicas de la mampara también necesitan algo de mantenimiento para conseguir su perfecto funcionamiento por muchos años. Los rodamientos y partes articuladas de la mampara se deben lubricar ligeramente. También se deben apretar los tornillos que permanezcan visibles.

RECUBRIMIENTO EASY-CLEAN.

El recubrimiento EASY-CLEAN es un tratamiento especial por el cual el vidrio adquiere una capa superficial extralisa que impide que se puedan adherir de forma persistente gotas de agua, restos de jabón, de suciedad o de cal. La limpieza no se evita pero se consigue eliminar todos los restos de una forma sencilla y sin esfuerzo.

Para la limpieza de la superficie de vidrio recubierta con tratamiento EASY-CLEAN se deben utilizar paños no abrasivos y agentes de limpieza no abrasivos.

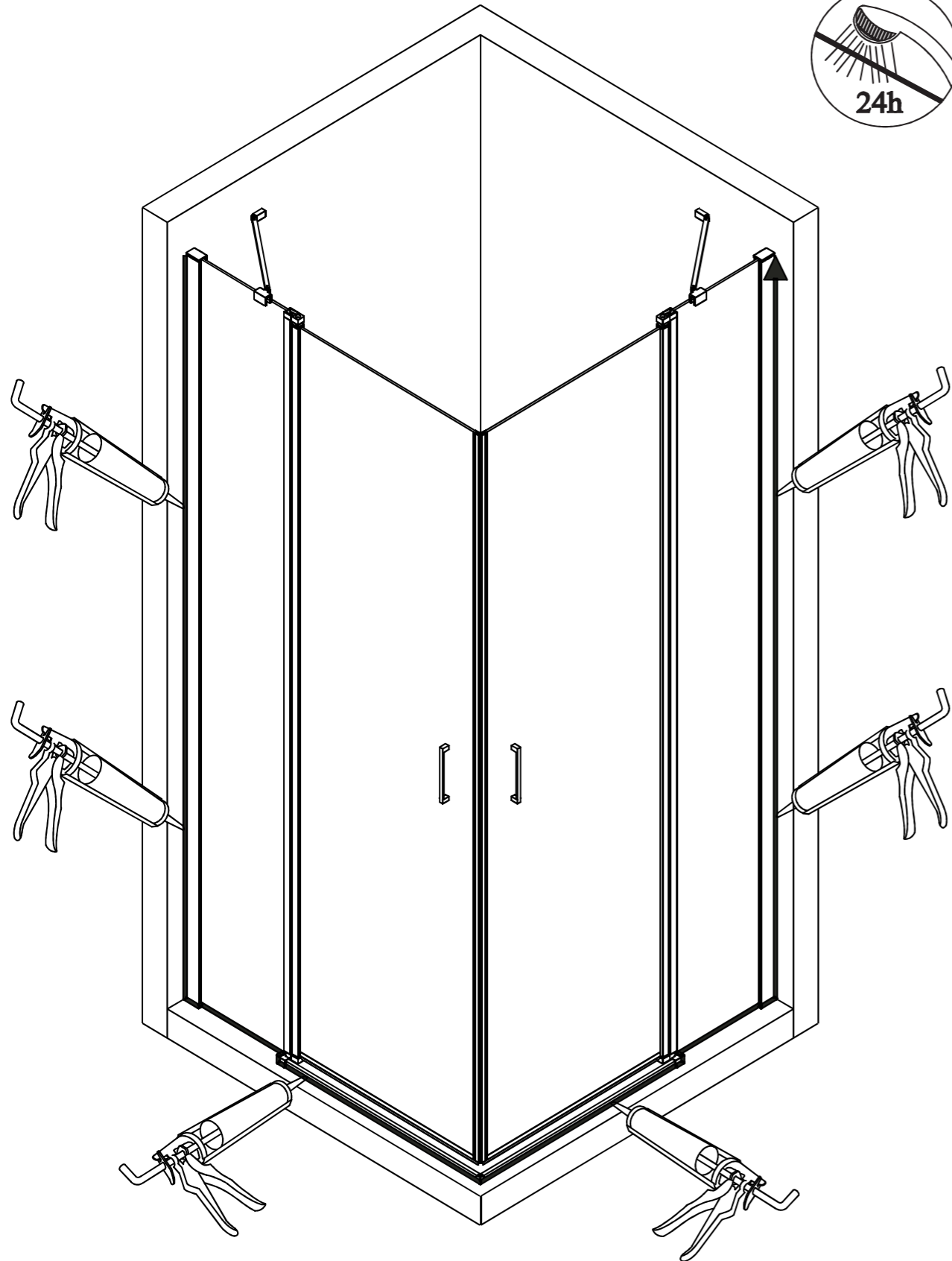

ESQUEMA/SCHEME/SCHÉMA/SCHEMA

09

45

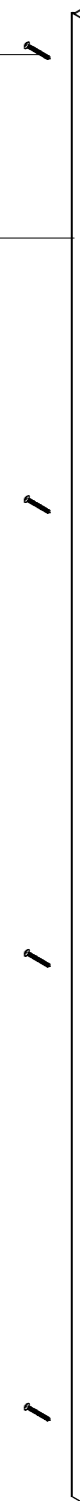

Nº	DIBUJO	CODIGO	DESCRIPCION	UNIDADES	UDS/ MAMPARA
09		22MAATORNS639035	Tornillos ST4x35 Screw ST4x35 Vis ST4x35 Schraube ST4x35	Uds	4

Nº	DIBUJO	CODIGO	DESCRIPCION	UNIDADES	UDS/ MAMPARA
45		33PNAAN161950AAA	Perfil de ampliación Profile of expansion Extension de profil Profil von expansion	Uds	1

ES DESGLOSE DE COMPONENTES
GB BREAKDOWN OF COMPONENTS

FR COMPOSANTS DE VENTILATION
DE AUFSCHLÜSSELUNG DER KOMPONENTEN

ESQUEMA/SCHEME/SCHEMA/SCHEMA



Nº	DIBUJO	CODIGO	DESCRIPCION	UNIDADES	Uds/ MAMPARA
06		22MAATACOS001006	Taco S-6 Rawlplug S-6 Chevilles S-6 Dübel S-6	Uds	1
30		33RNAMA101906AAA	Iman angular Magnet angle L'angle de l'aimant Magnet Winkel	Uds	1
31		33RNAMN101906AAB	Iman angular Magnet angle L'angle de l'aimant Magnet Winkel	Uds	1

Nº	DIBUJO	CODIGO	DESCRIPCION	UNIDADES	Uds/ MAMPARA
32		22MNATATAPOS02012	Tapón codo de unión Plug elbow union Raccord à fiche Stecker Winkelstück	Uds	1
33		22MNAACODOS001012	Codo unión perfil de retención Elbow union profile retention Profil de maintien coude Winkelstück profil der aufbewahrung	Uds	1
34		22MAATORNSS539035	Tornillos ST4x35 Screw ST4x35 Vis ST4x35 Schraube ST4x35	Uds	1

47

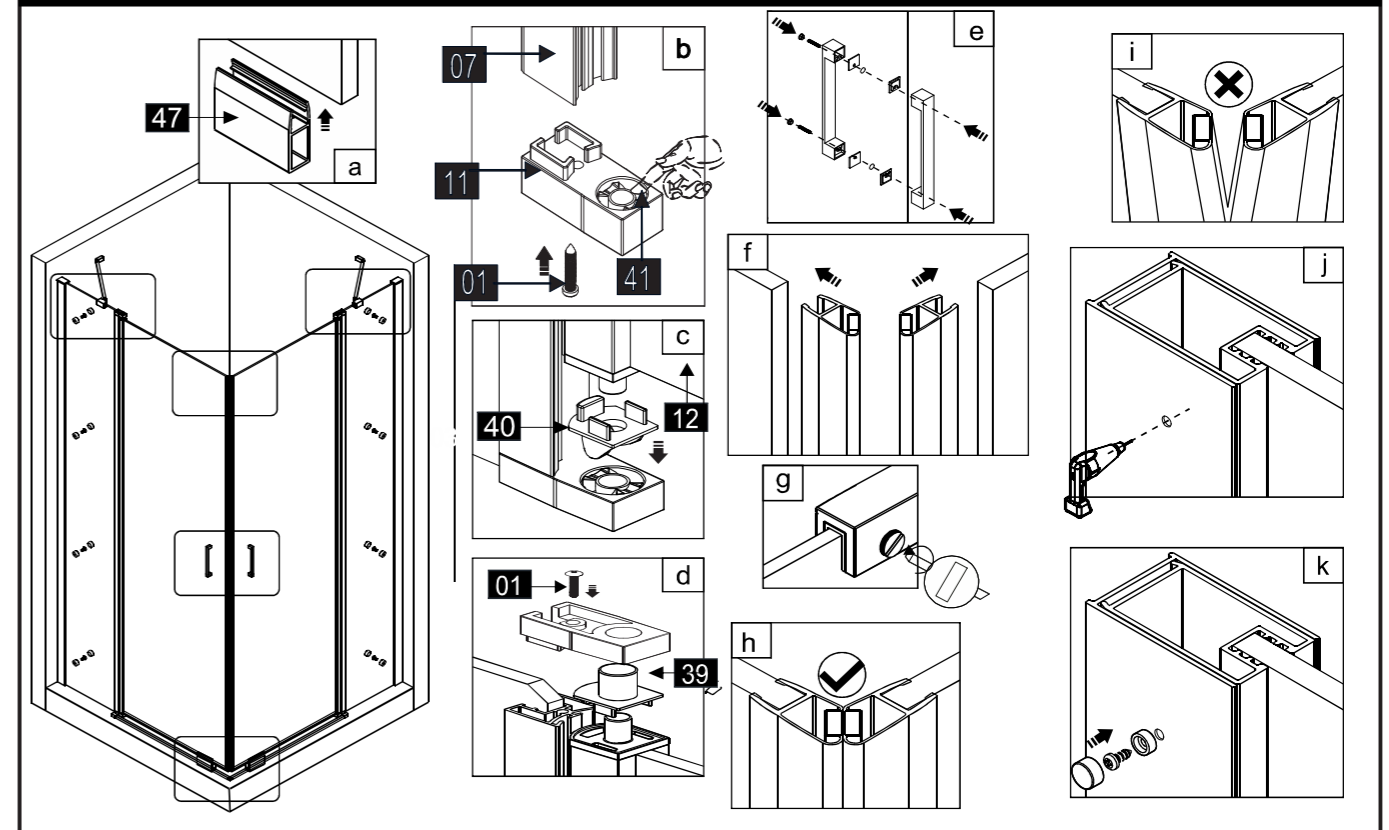

48

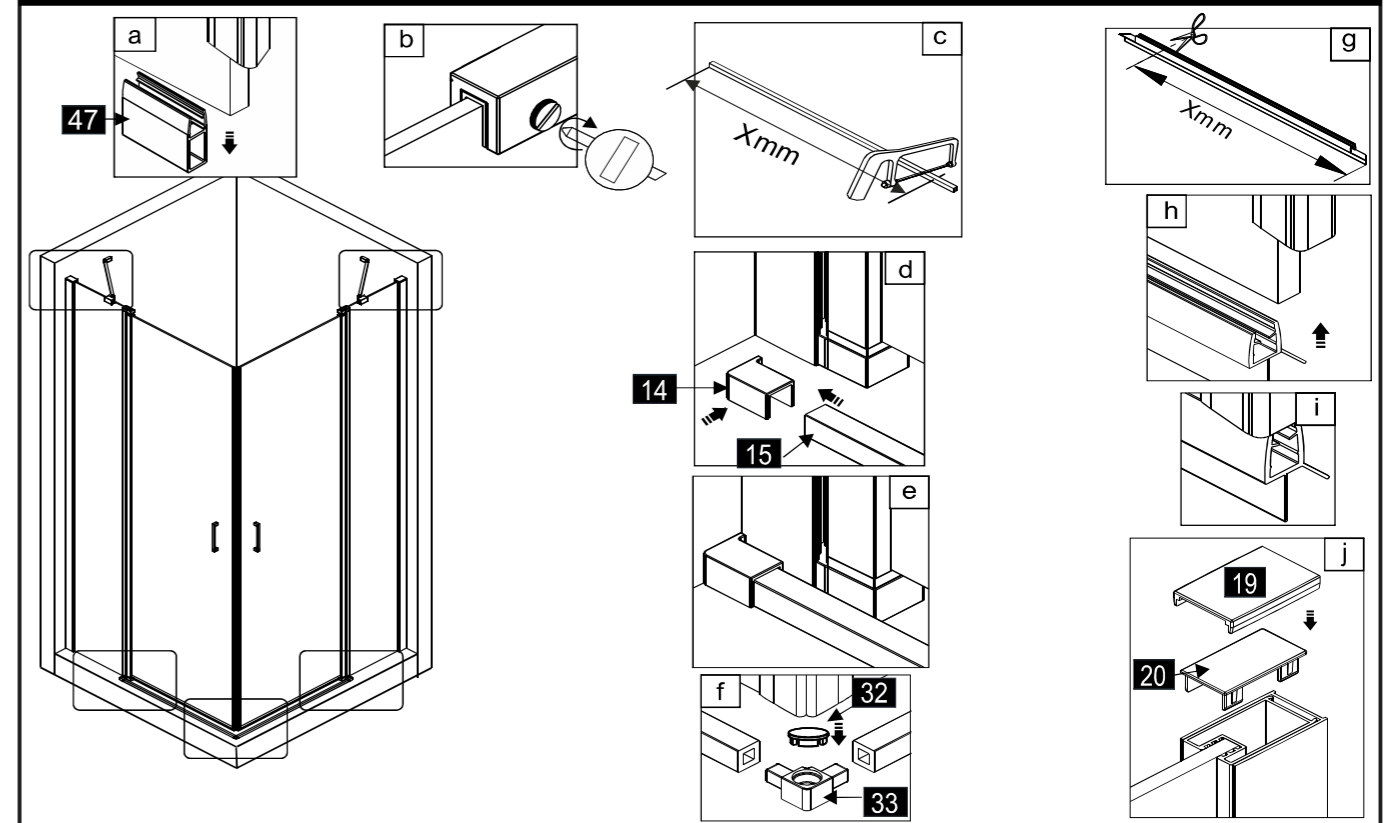

45

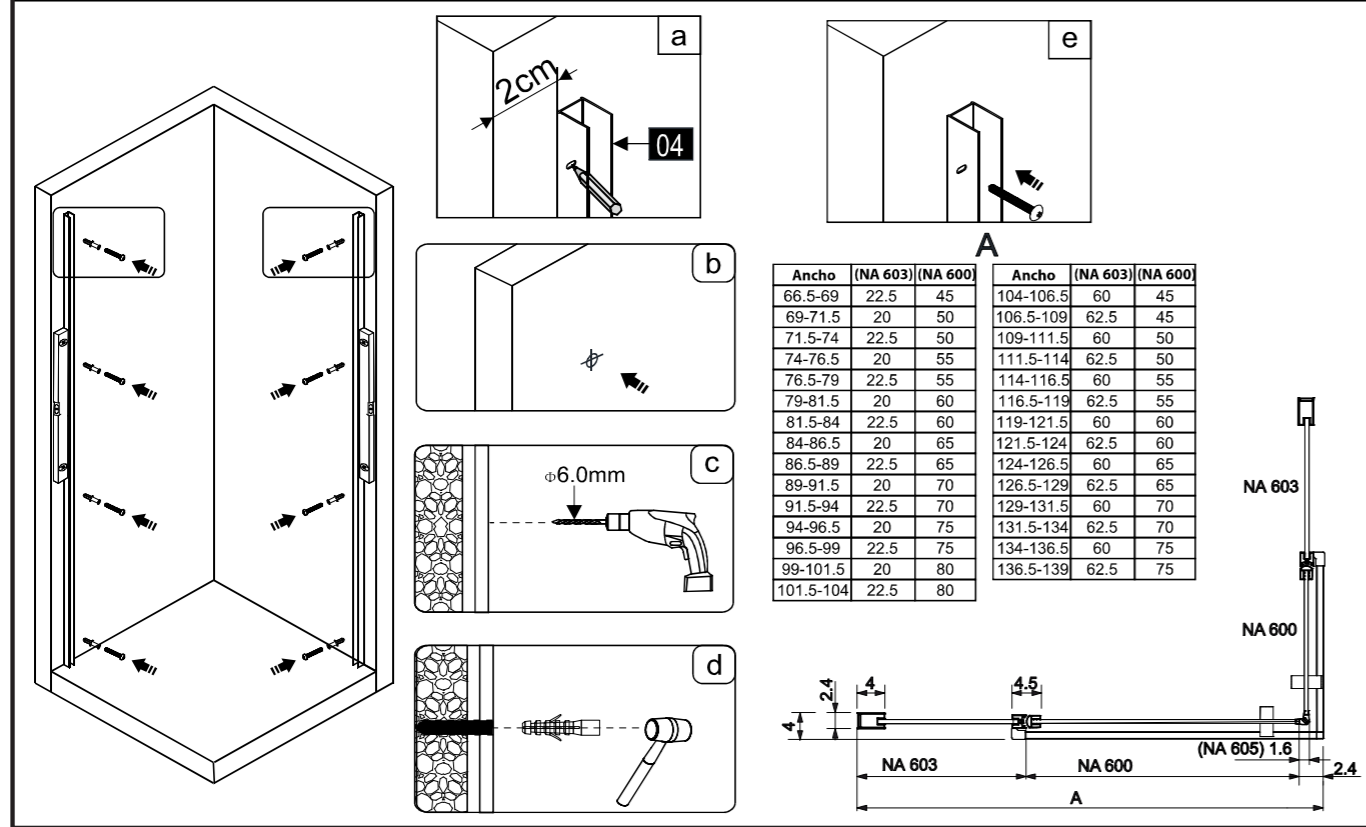

46

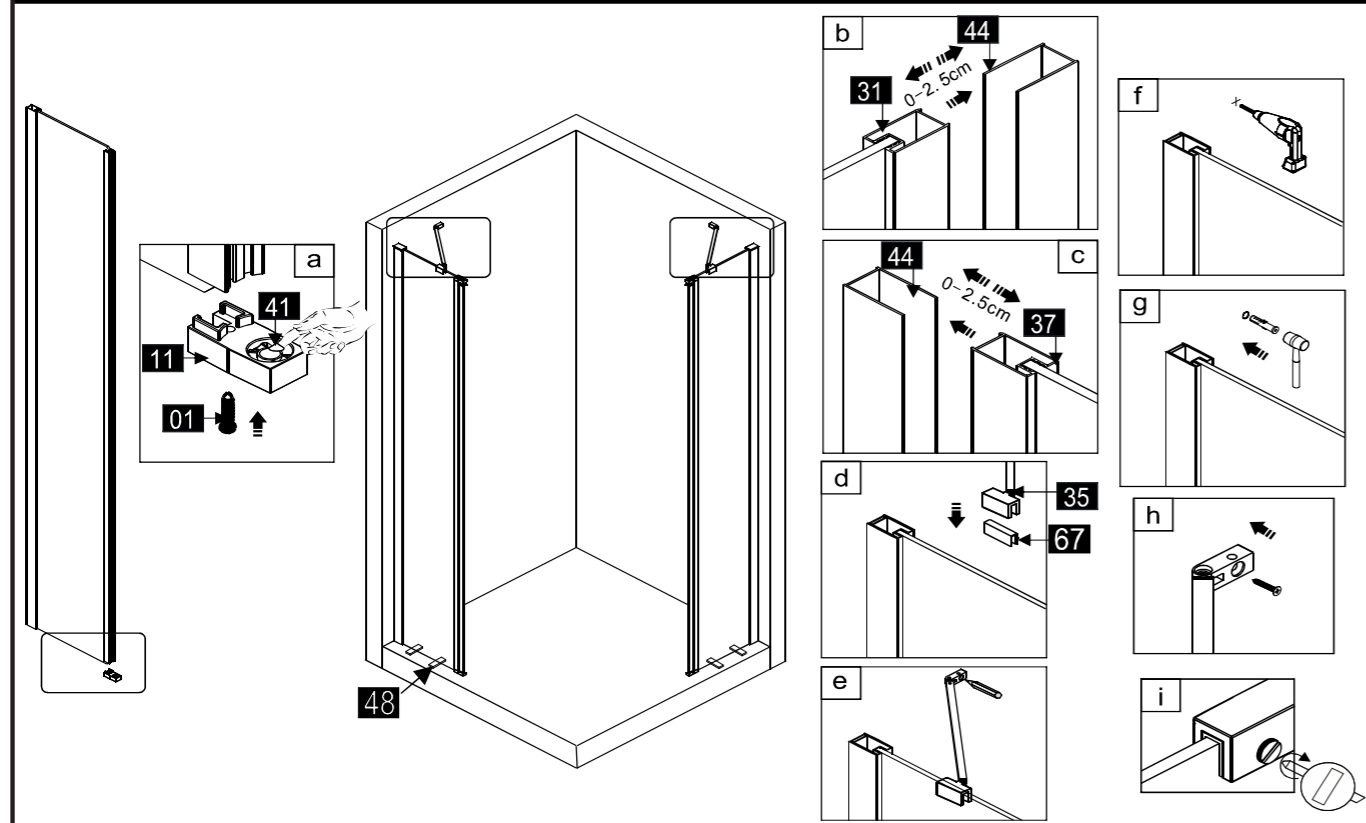

ES DESGLOSE DE COMPONENTES
GB BREAKDOWN OF COMPONENTS

FR COMPOSANTS DE VENTILATION
DE AUFSCHLÜSSELUNG DER KOMPONENTEN

ESQUEMA/SCHEME/SCHÉMA/SCHEMA

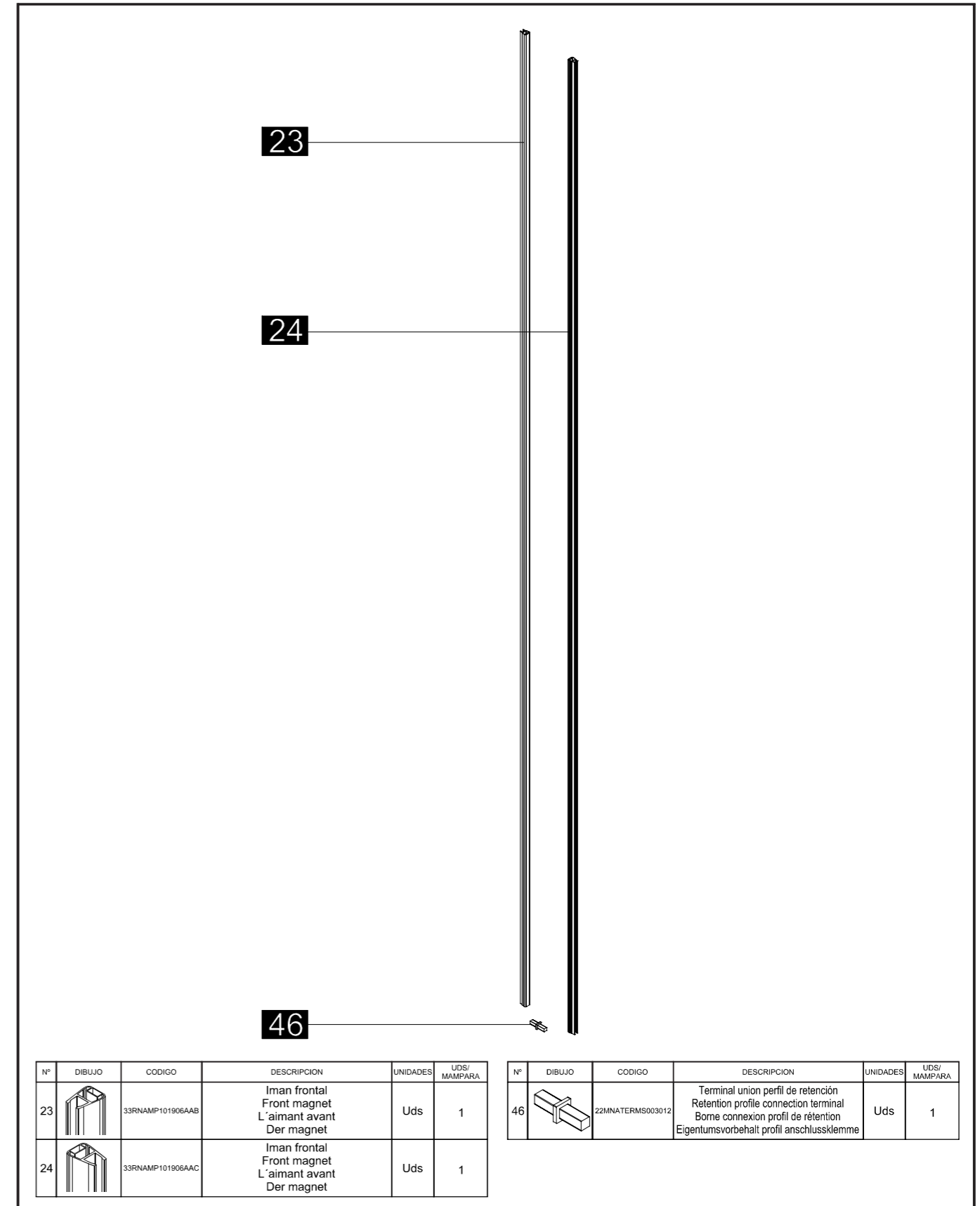

ES DESGLOSE DE COMPONENTES
GB BREAKDOWN OF COMPONENTS

FR COMPOSANTS DE VENTILATION
DE AUFSCHLÜSSELUNG DER KOMPONENTEN

ESQUEMA/SCHEME/SCHEMA/SCHEMA

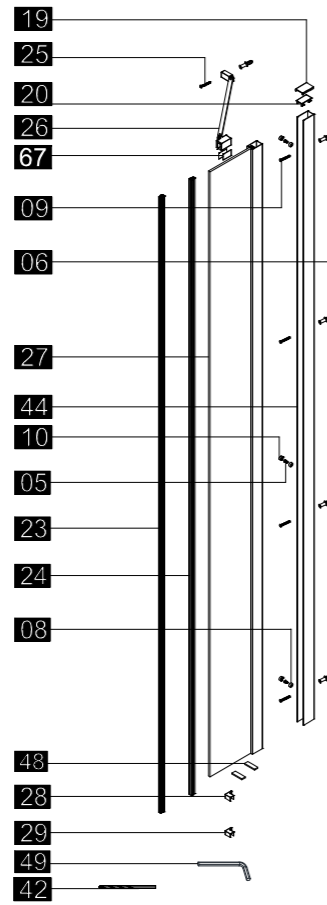

Nº	DIBUJO	CODIGO	DESCRIPCION	UNIDADES	UDS/ MAMPARA
05		22MAATORNS539010	Tornillos ST4x10 Screw ST4x10 Vis ST4x10 Schraube ST4x10	Uds	3
06		22MAATACOS001006	Taco S-6 Rawlplug S-6 Chevilles S-6 Dübel S-6	Uds	5
08		22MNATAPOS001012	Tapa tornillo Cap Screw La vis Sechskantschraube	Uds	3
10					
09		22MAATORNS539035	Tornillos ST4x35 Screw ST4x35 Vis ST4x35 Schraube ST4x35	Uds	4
19		22MNATAPOS002012	Tapa de compensador perfil de cierre Cap compensator close profile Profil de compensateur de la pac Cap kompensator schliessen profil	Uds	1
20		22MNATAPOS003012	Tapa perfil de cierre Lid close profile Couvercle profil fermer Deckel schließen profil	Uds	1
23		33RNAMP101906AAB	Iman frontal Front magnet L'aimant avant Der magnet	Uds	1
24		33RNAMP101906AAC	Iman frontal Front magnet L'aimant avant Der magnet	Uds	1

Nº	DIBUJO	CODIGO	DESCRIPCION	UNIDADES	UDS/ MAMPARA
25		22MAATORNS440035	Tornillos ST4x35 Screw ST4x35 Vis ST4x35 Schraube ST4x35	Uds	1
26		22MNBRAZS006012 22MNBRAZS007012	Brazo articulado Articulated arm Bras articulé Gelenkarm	Uds	1
27			Fijo fixed fixe festgelegt	Uds	1
28		22MNATERM004012	Terminal fijo a continuacion izquierdo Fixed Terminal below left Fixed Terminal unten links Terminal unten links	Uds	1
29		22MNATERMD004012	Terminal fijo a continuacion derecho Fixed Terminal then right Terminal fixe puis à droite Fixed Terminal dann rechts	Uds	1
42		55CAABRWIS000320	Broca D:3.2 Bit D:3.2 Foret D:3.2 Steinbohred D:3.2	Uds	1
44		33PNACC161925AAA	Compensador perfil de cierre Compensator close profile Profil de compensateur Kompensator schließen profil	Uds	1
48		22MADCALZS015010	Calzo hoja fija Chock fixed blade Caler la lame fixe Keil mit fester Klinge	Uds	2
49		55UAALLALS001002	Llave allen de 2mm Allen wrench of 2mm Clé Allen 2mm Inbusschlüssel 2mm	Uds	1

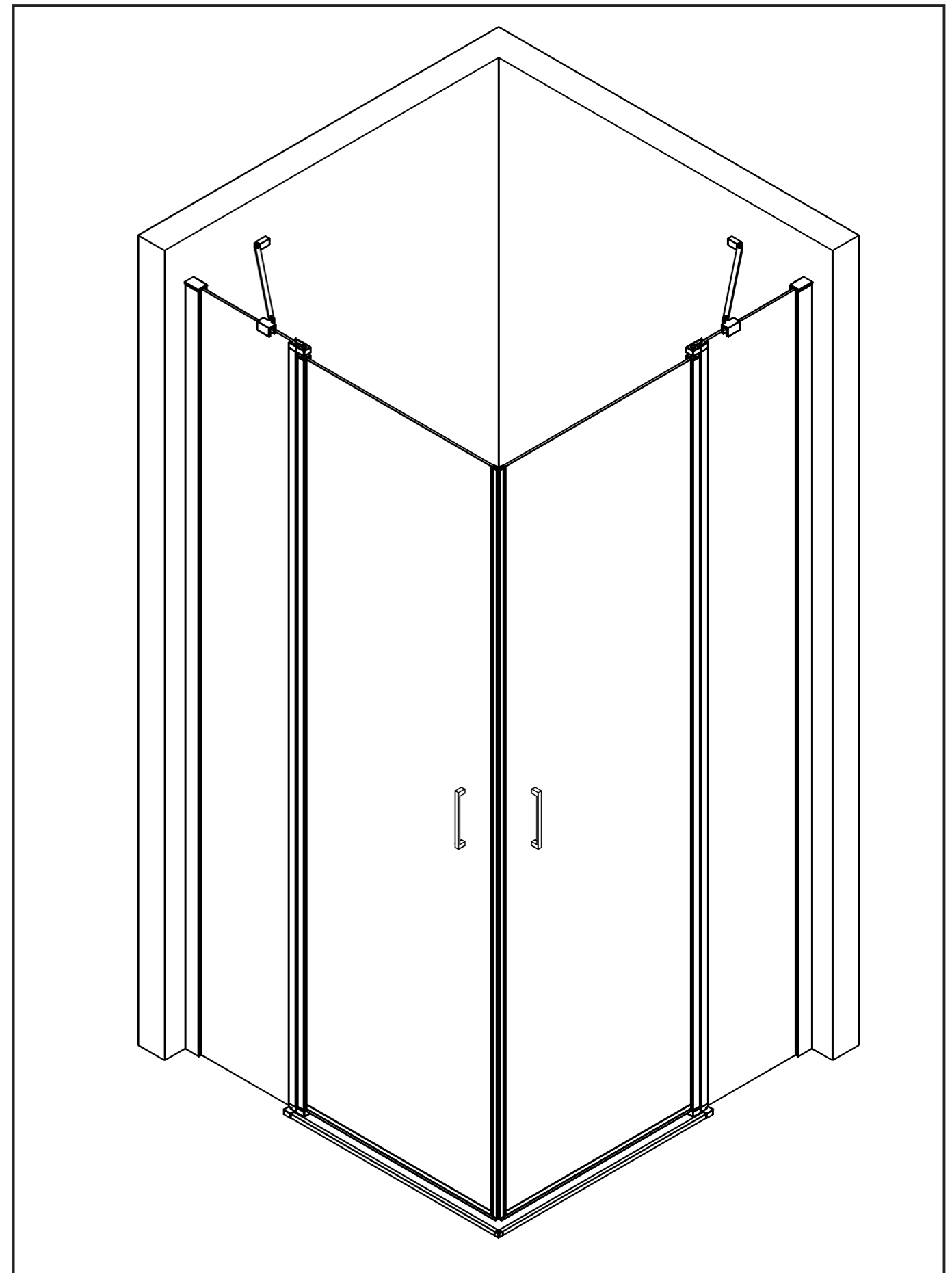

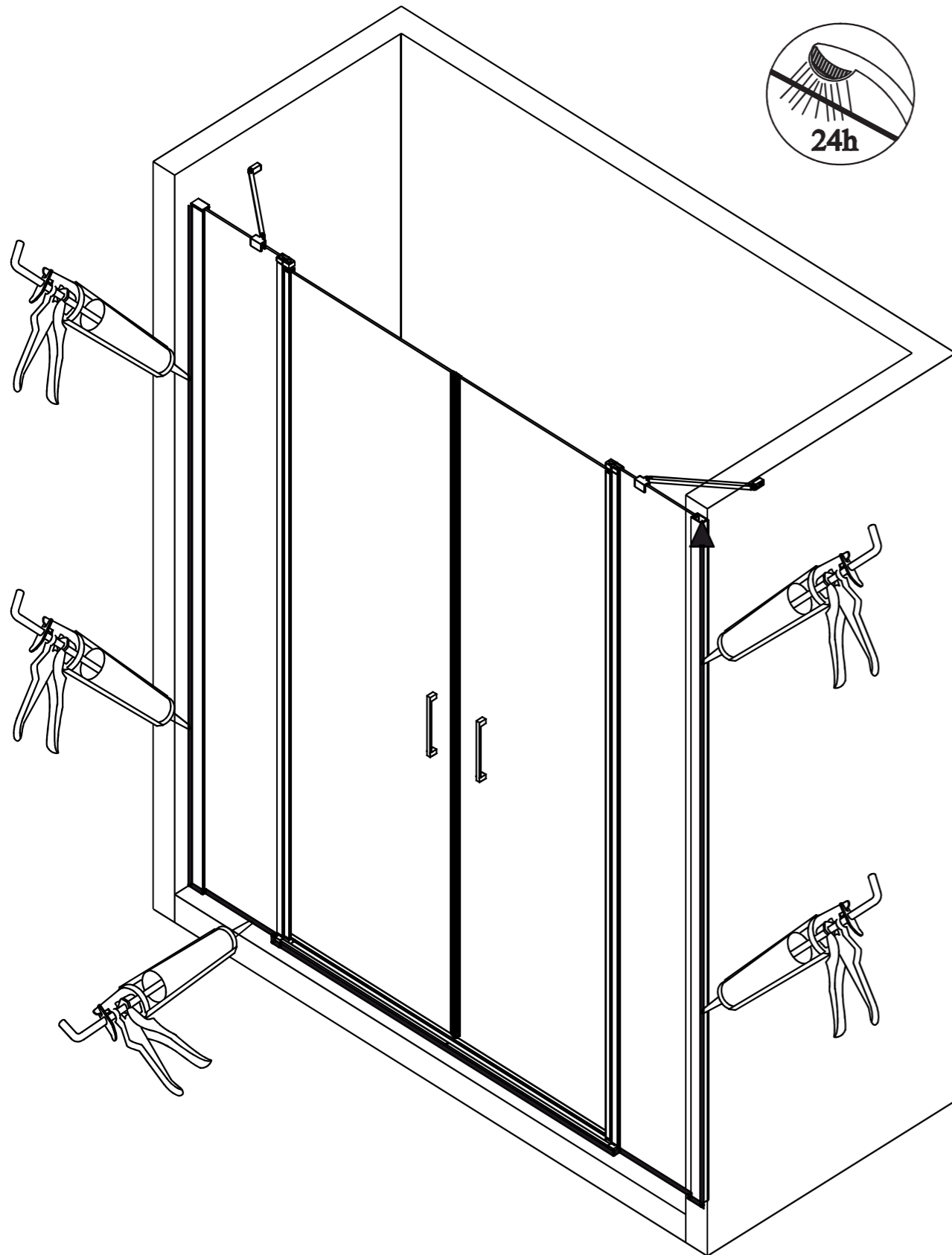

ES DESGLOSE DE COMPONENTES
GB BREAKDOWN OF COMPONENTS

FR COMPOSANTS DE VENTILATION
DE AUFSCHLÜSSELUNG DER KOMPONENTEN

ESQUEMA/SCHEME/SCHÉMA/SCHEMA

Nº	DIBUJO	CODIGO	DESCRIPCION	UNIDADES	UDS/ MAMPARA
05		22MAATORNS539010	Tornillos ST4x10 Screw ST4x10 Vis ST4x10 Schraube ST4x10	Uds	3
06		22MAATACOS001006	Taco S-6 Rawplug S-6 Chevilles S-6 Dübel S-6	Uds	5
08		22MNATAPOS001012	Tapa tornillo Cap Screw La vis Sechskantschraube	Uds	3
10					
09		22MAATORNS539035	Tornillos ST4x35 Screw ST4x35 Vis ST4x35 Schraube ST4x35	Uds	4
19		22MNATAPE002012	Tapa de compensador perfil de cierre Cap compensator close profile Profil de compensateur de la pac Cap compensator schliessen profil	Uds	1
20		22MNATAPE003012	Tapa perfil de cierre Lid close profile Couvercle profil fermer Deckel schließen profil	Uds	1
23		33RNAMP101906AAB	Iman frontal Front magnet L'aimant avant Der magnet	Uds	1
25		22MAATORNS440035	Tornillos ST4x35 Screw ST4x35 Vis ST4x35 Schraube ST4x35	Uds	1
60		22MNABRAZS008012 22MNABRAZS009012 22MNABRAZS010012	Brazo articulado Articulated arm Bras articulé Gelenkarm	Uds	1
61			Fijo fixed fixe festgelegt	Uds	1
62		22MNAML101925AAA	Iman fijo lateral Magnet fixed side Côté fixe de l'aimant Magnet feste Seite	Uds	1
63		22MNATERMD005012	Terminal fijo lateral derecho Fixed Terminal right side Terminal fixe côté droit Fixed Terminal rechts	Uds	1
64		22MNATERMI005012	Terminal fijo lateral izquierdo Fixed terminal side Côté terminal fixe Fixed Terminal Seite	Uds	1
42		55CAABRWIS000320	Broca D:3.2 Bit D:3.2 Foret D:3.2 Steinbohrer D:3.2	Uds	1
44		33PNAACC161925AAA	Compensador perfil de cierre Compensator close profile Profil de compensateur Kompensator schließen profil	Uds	1
48		22MADCALZS015010	Calzo hoja fija Chock fixed blade Caler la lame fixe Keil mit fester Klinge	Uds	2
49		55UAALLAL5001002	Llave allen de 2mm Allen wrench of 2mm Clé Allen 2mm Inbusschlüssel 2mm	Uds	1
48		22MADCALZS015010	Calzo hoja fija Chock fixed blade Caler la lame fixe Keil mit fester Klinge	Uds	2
67		22MNAJUNTS002000	Junta barra Board Bar Bar conseil Board Bar	Uds	2

ES HERRAMIENTAS
GB TOOL

FR TRAVAILLER
DE BEARBEITEN

ESQUEMA/SCHEME/SCHEMA/SCHEMA

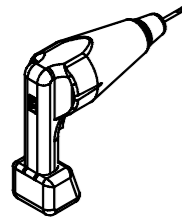

PERCEUSE
DRILL

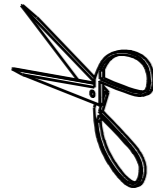

SCISSORS

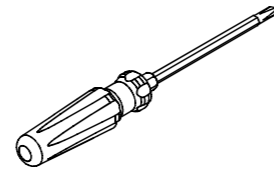

TOURNEVIS
SCREWDR



φ6mm

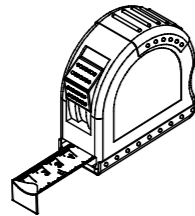

RUBAN À MESURER
MEASURING TAPE



ÉQUERRE
SET SQUARE

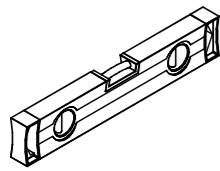

NIVEAU
LEVEL

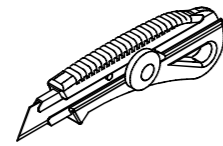

COUTEAU DE PRECISION
PRECISION KNIFE



SILICONE
SILICONE

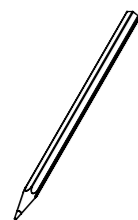

CRAYON
PENCIL

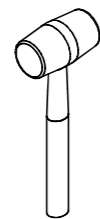

MAILLET
MALLET



INNER HEXAGON
SPANNER

42

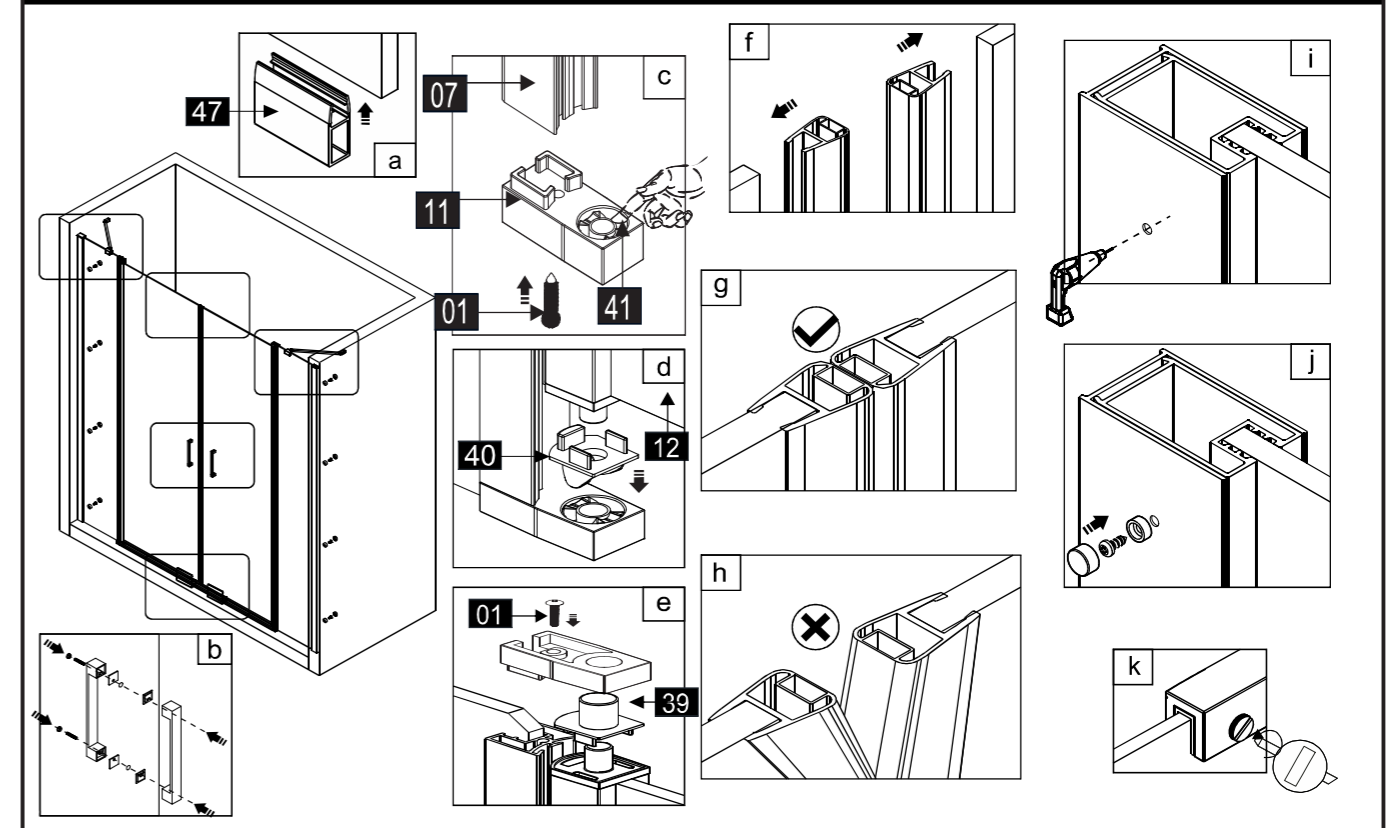

43

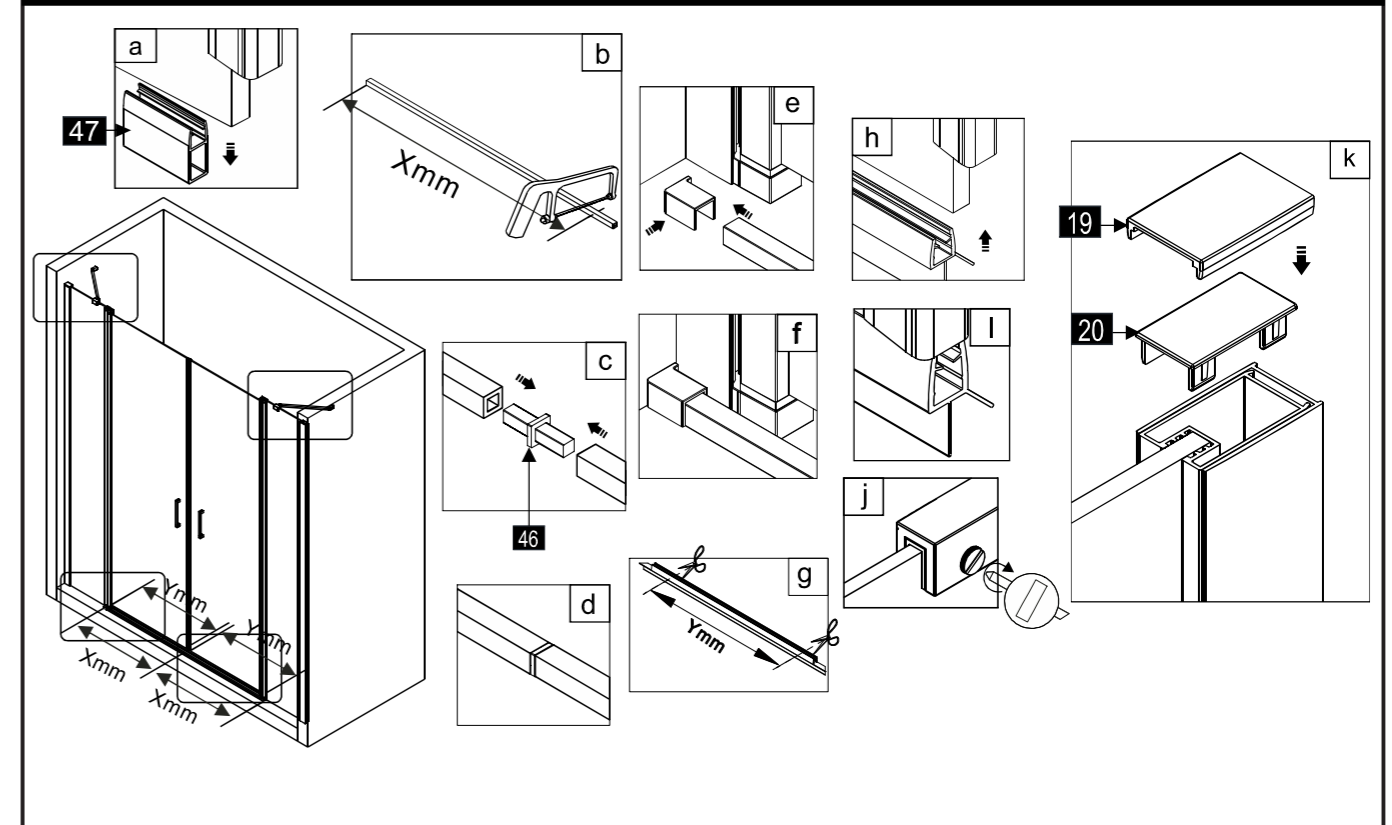

40

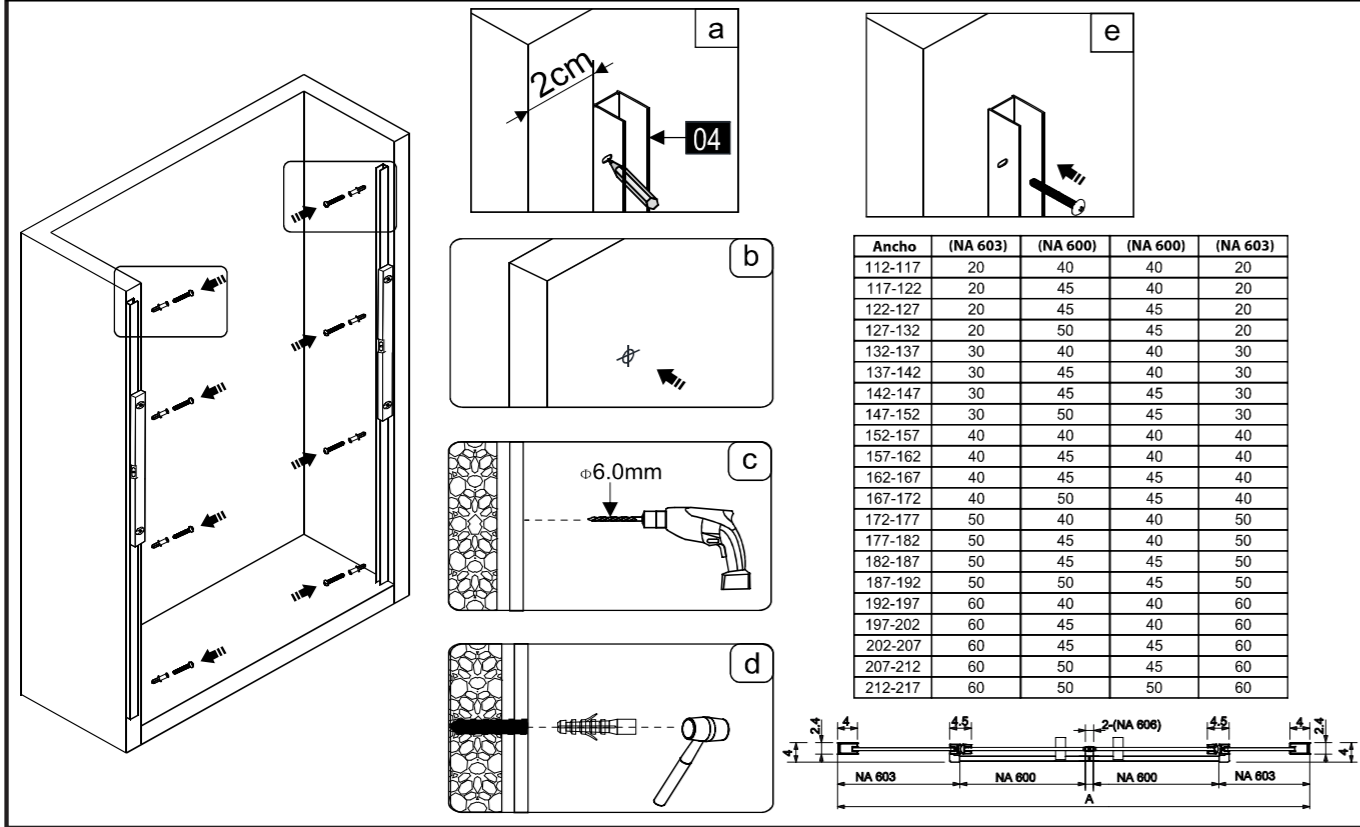

41

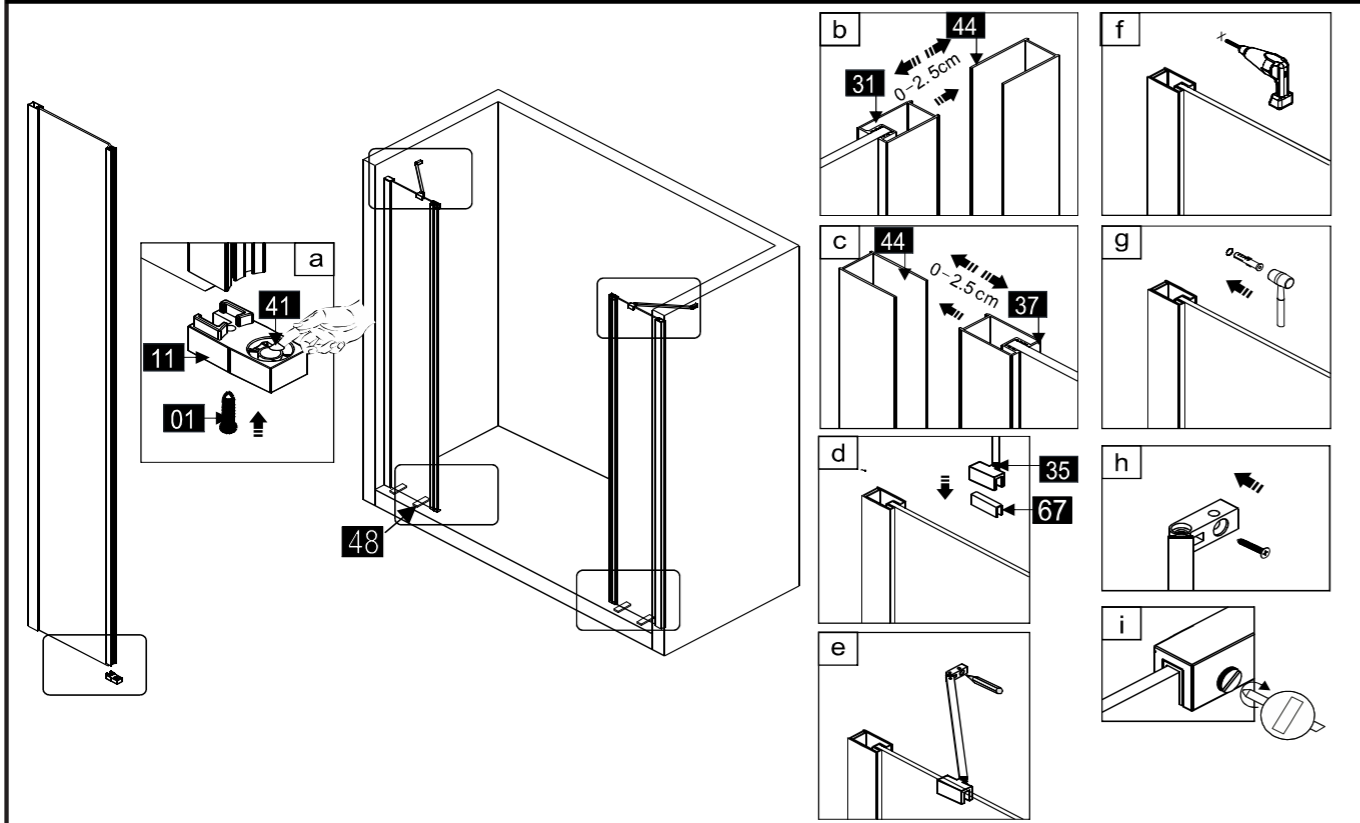

ES INSTRUCCIONES DE MONTAJE
GB INSTALLATION INSTRUCTIONS

FR INSTRUCTIONS D'INSTALLATION
DE MONTAGEANLEITUNG

ESQUEMA/SCHEME/SCHÉMA/SCHEMA

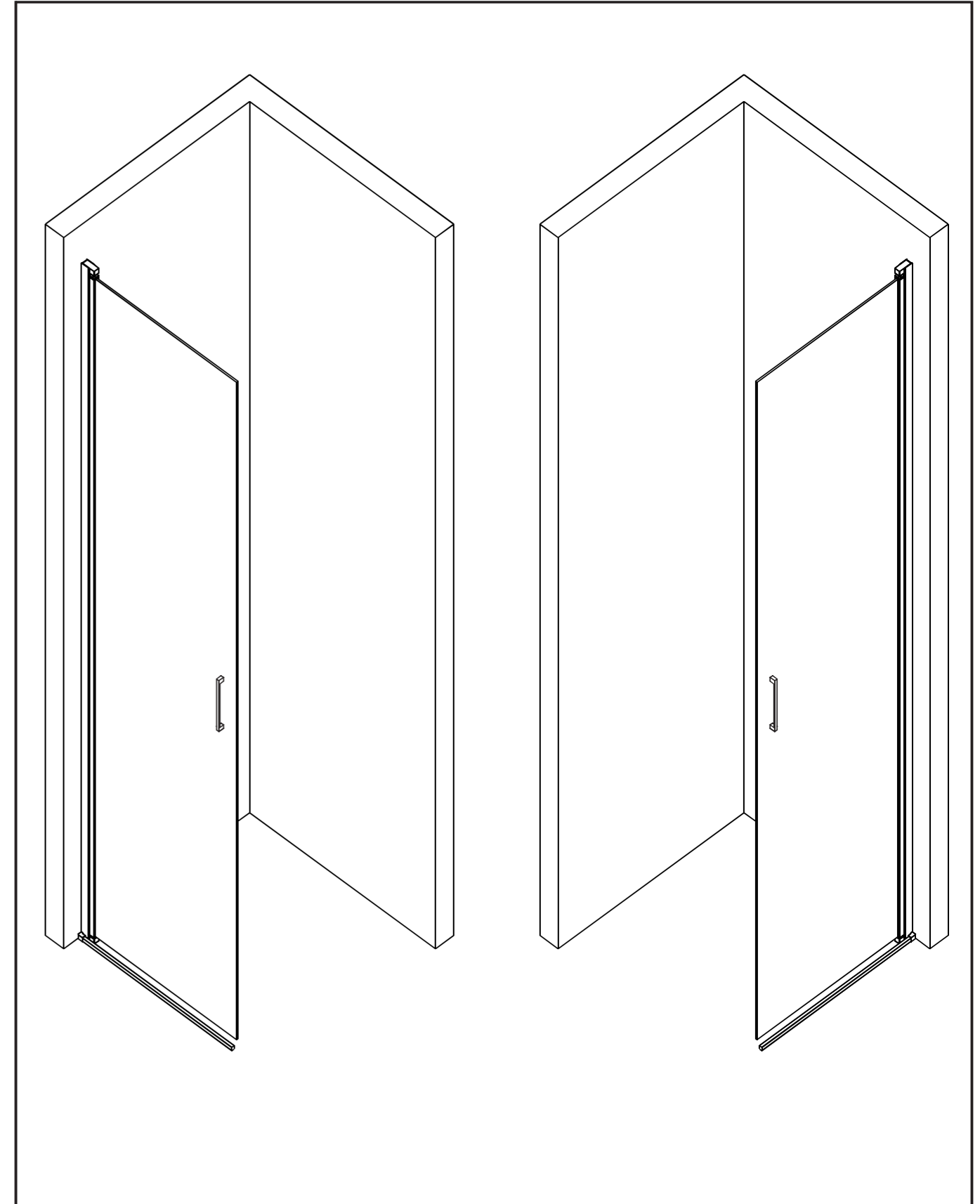

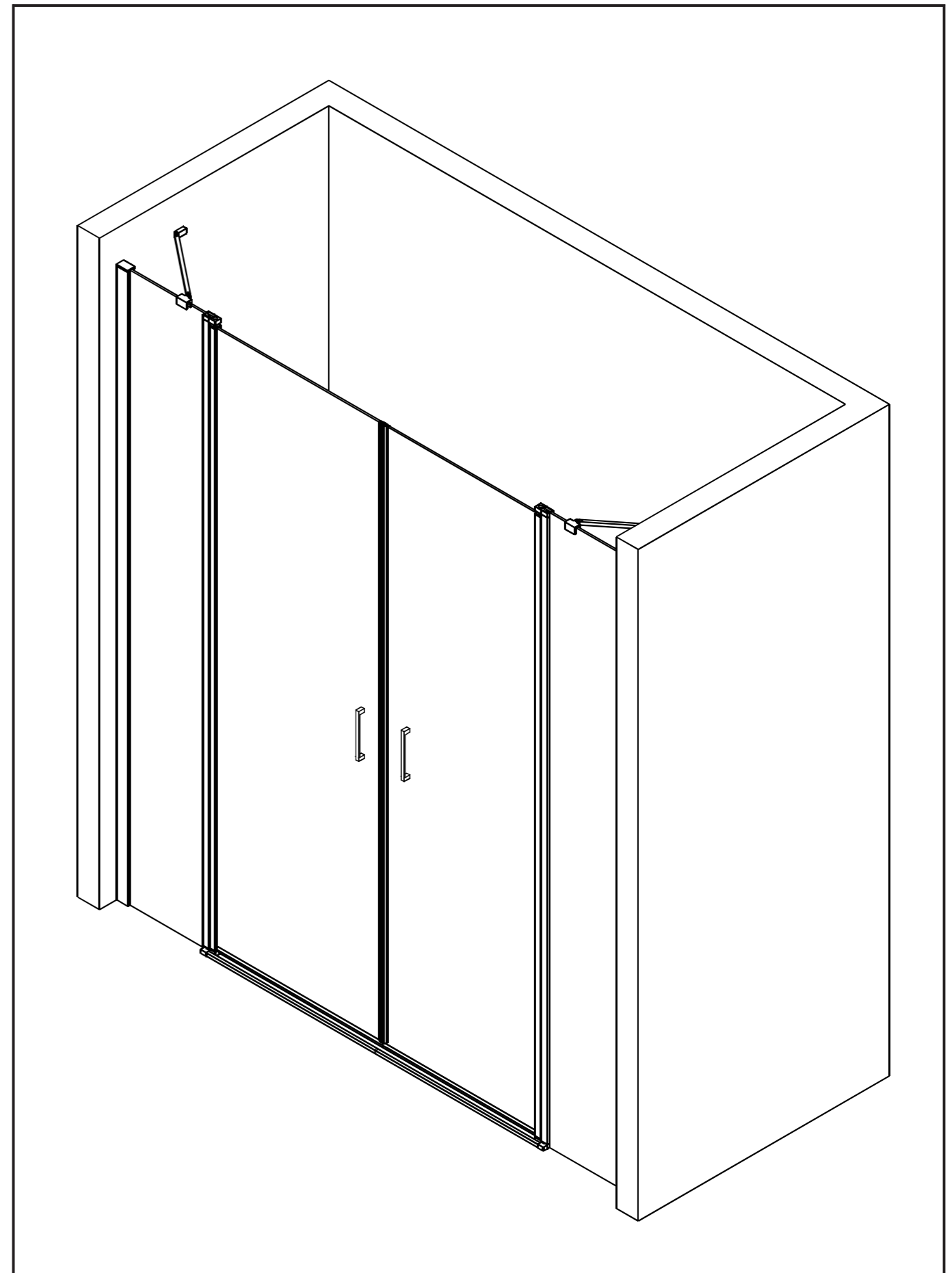
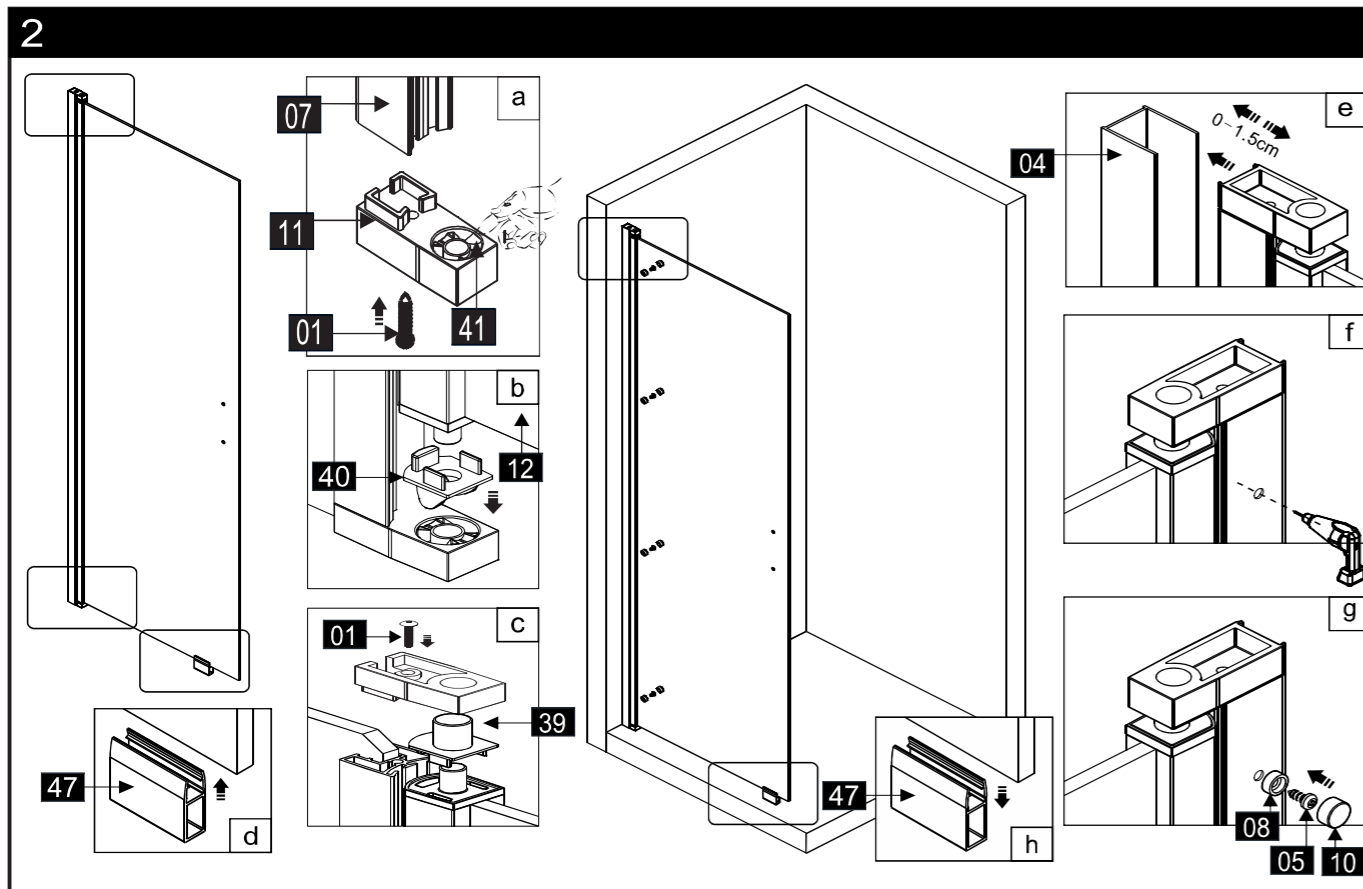
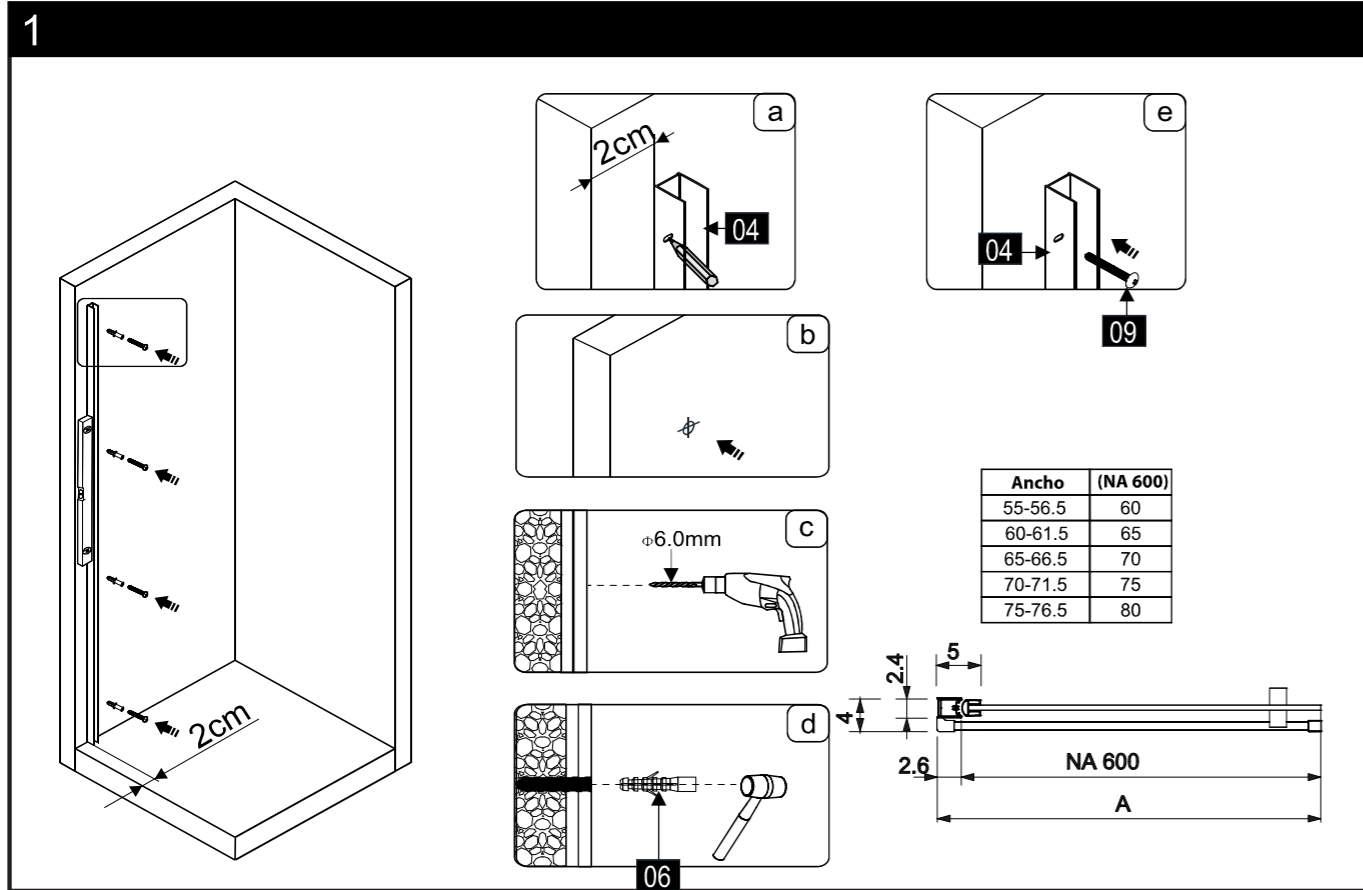

38

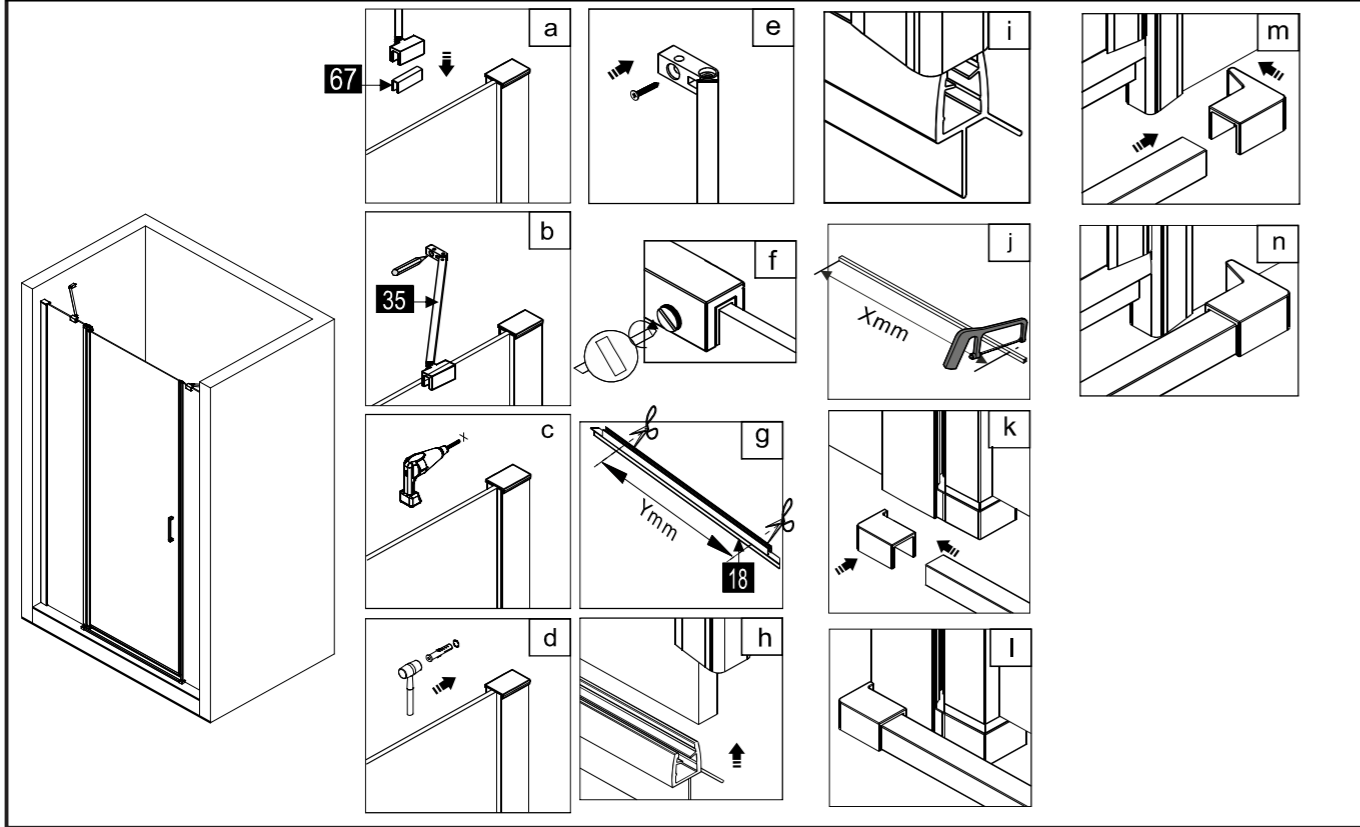

39

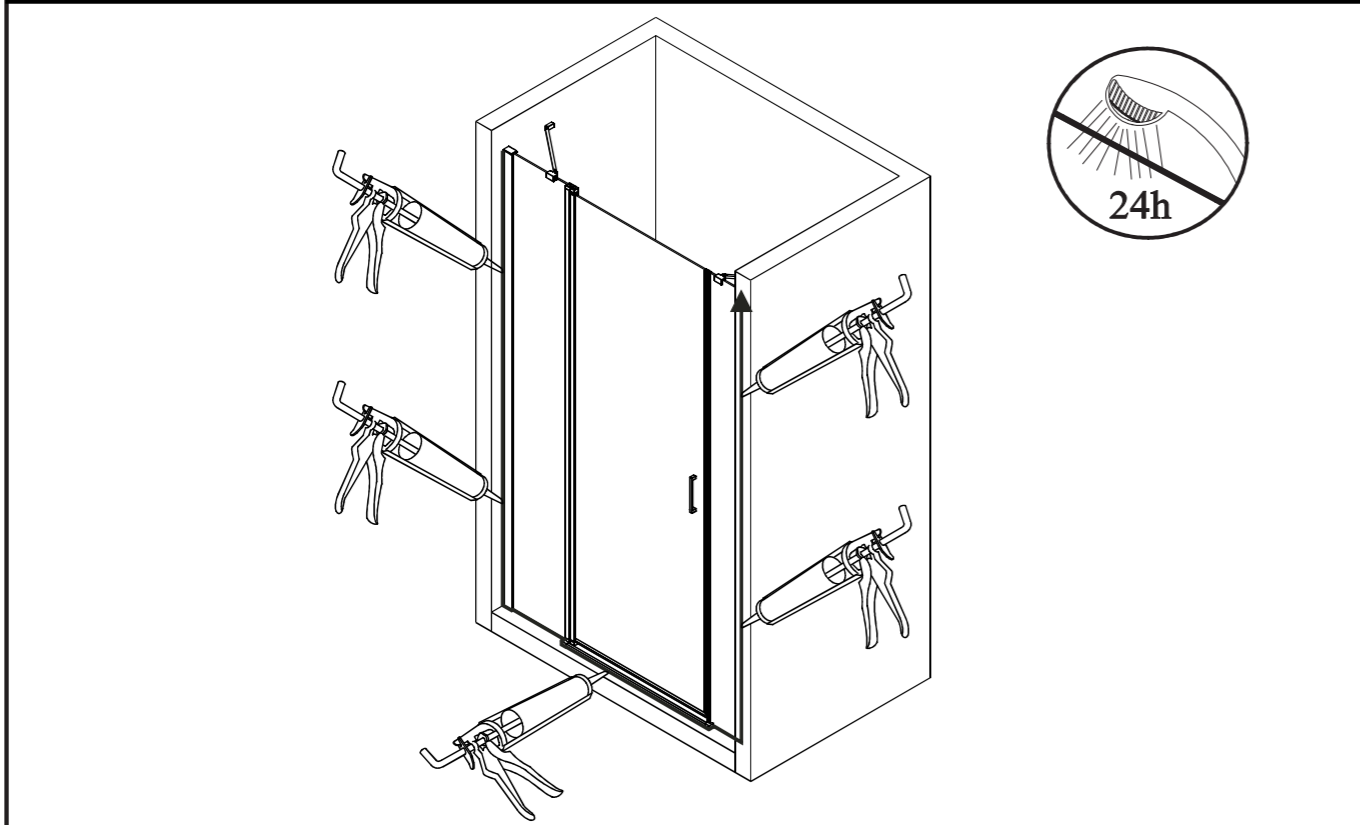

3

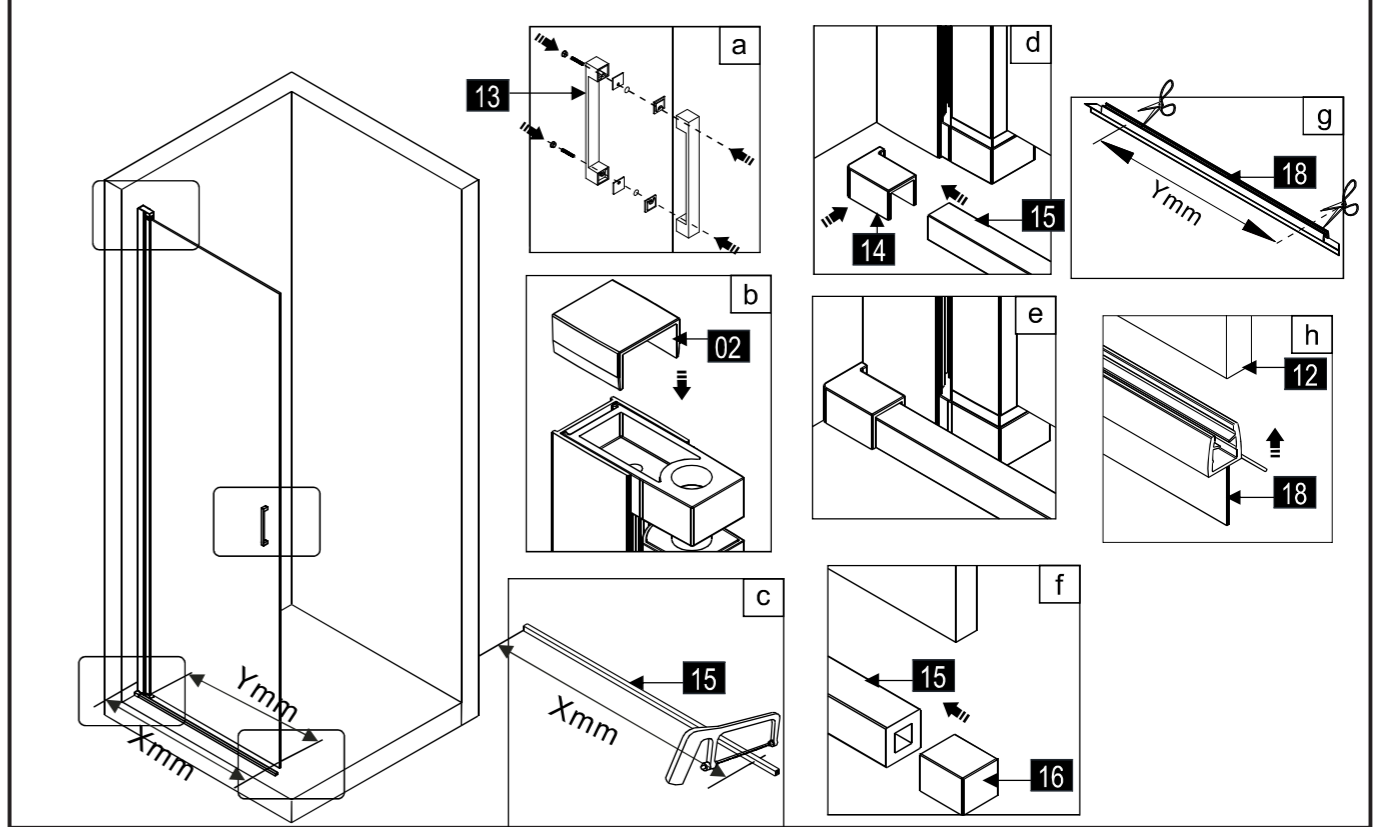

4

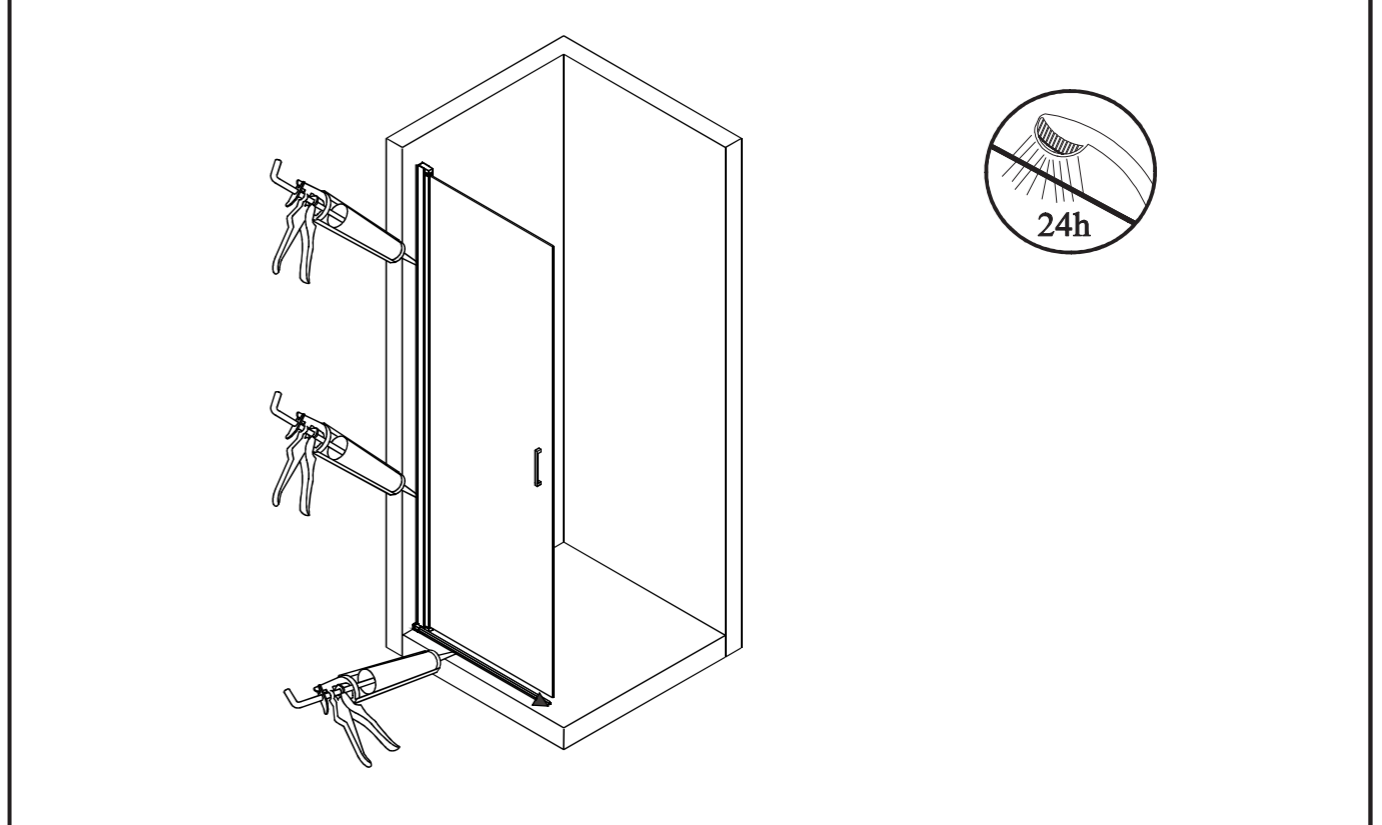

ES INSTRUCCIONES DE MONTAJE
GB INSTALLATION INSTRUCTIONS

FR INSTRUCTIONS D'INSTALLATION
DE MONTAGEANLEITUNG

ESQUEMA/SCHEME/SCHEMA/SCHEMA

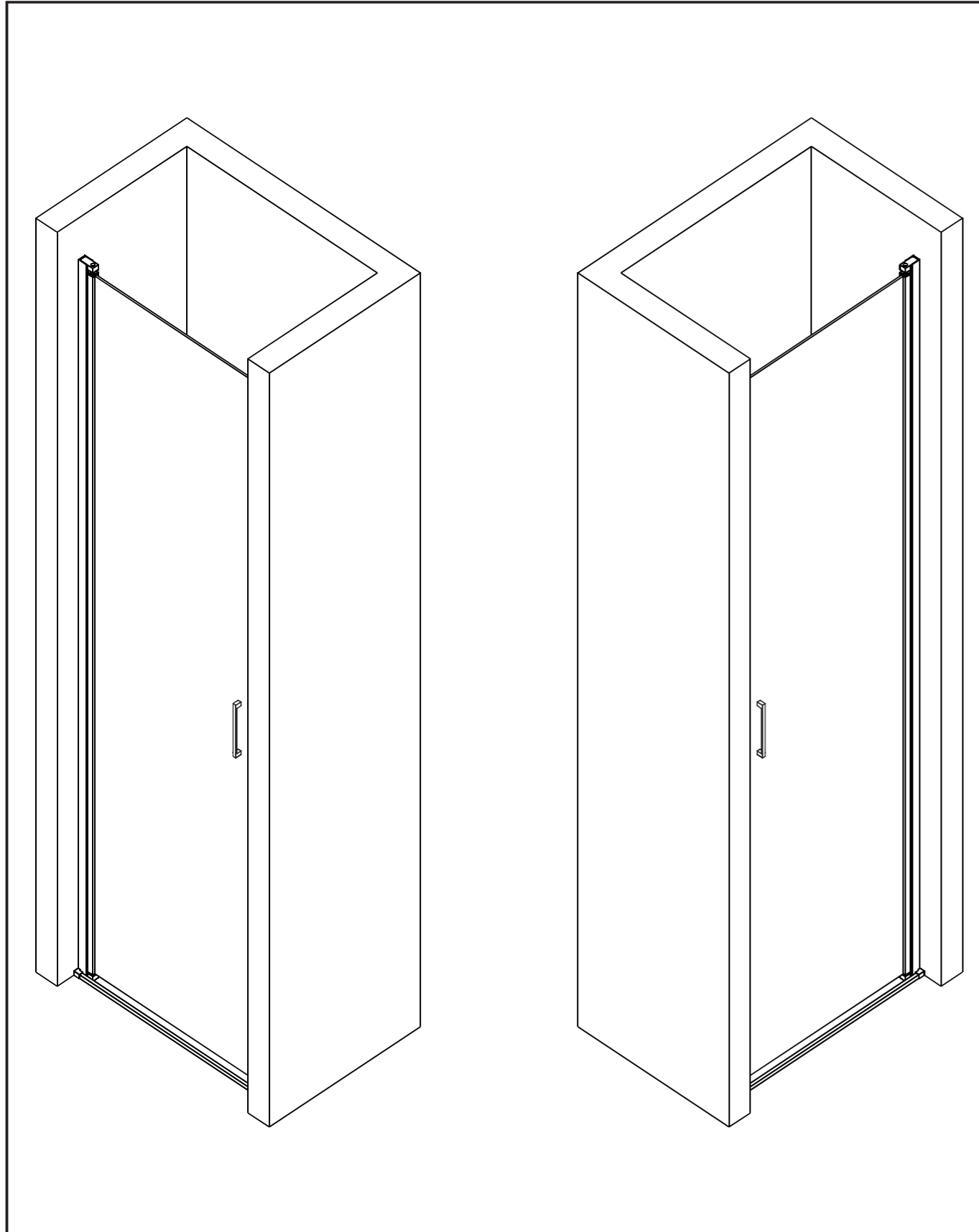

36

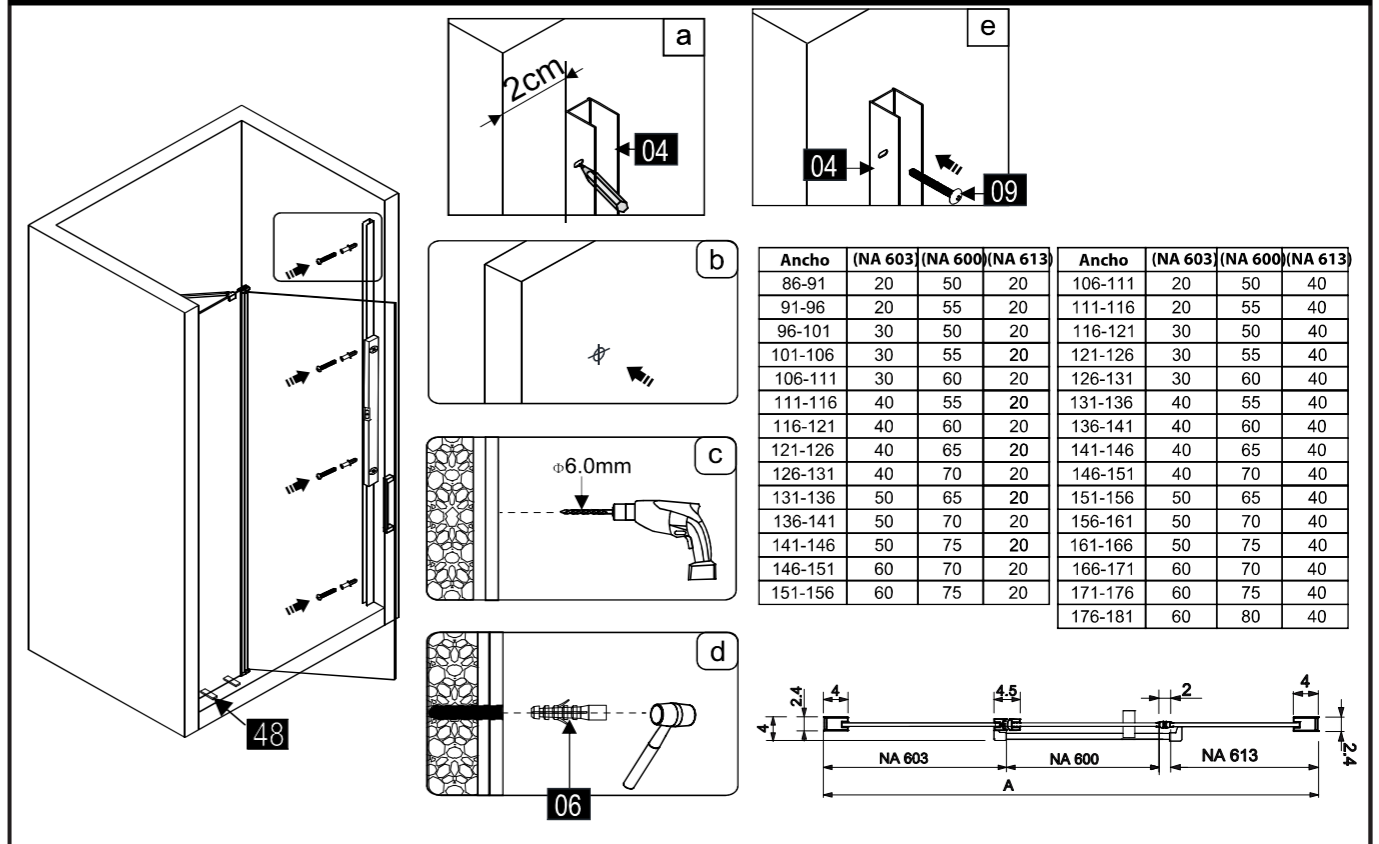

37

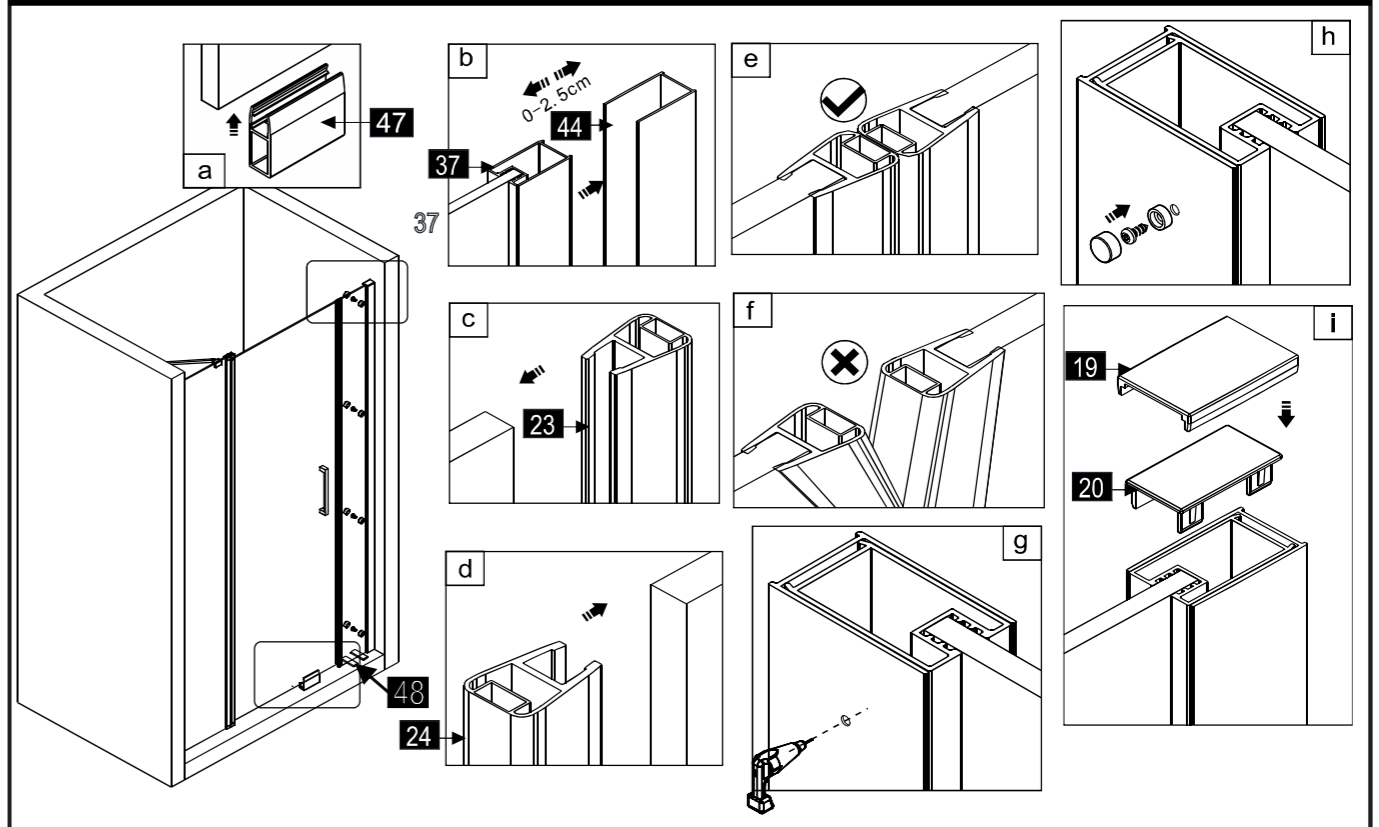

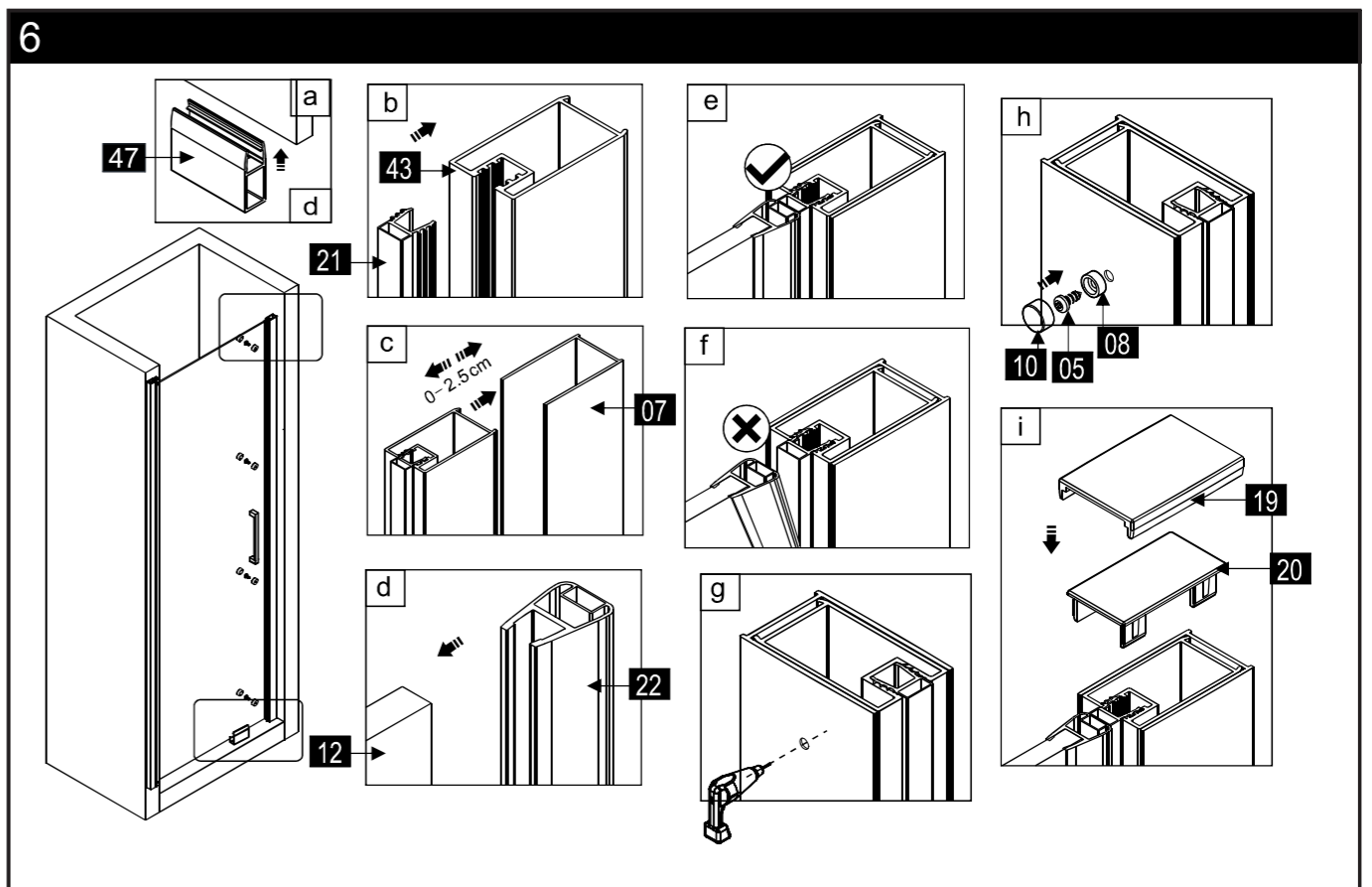
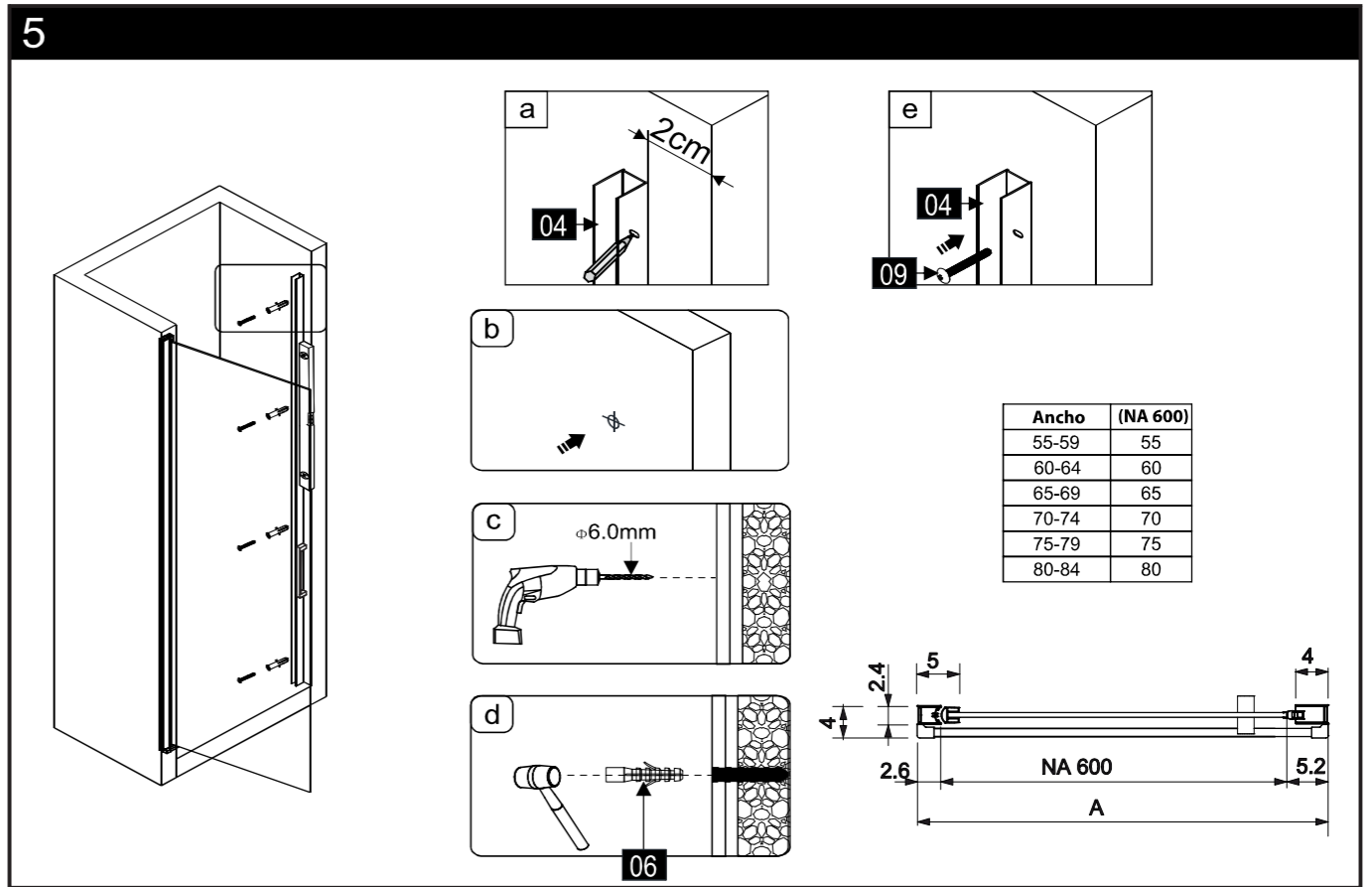
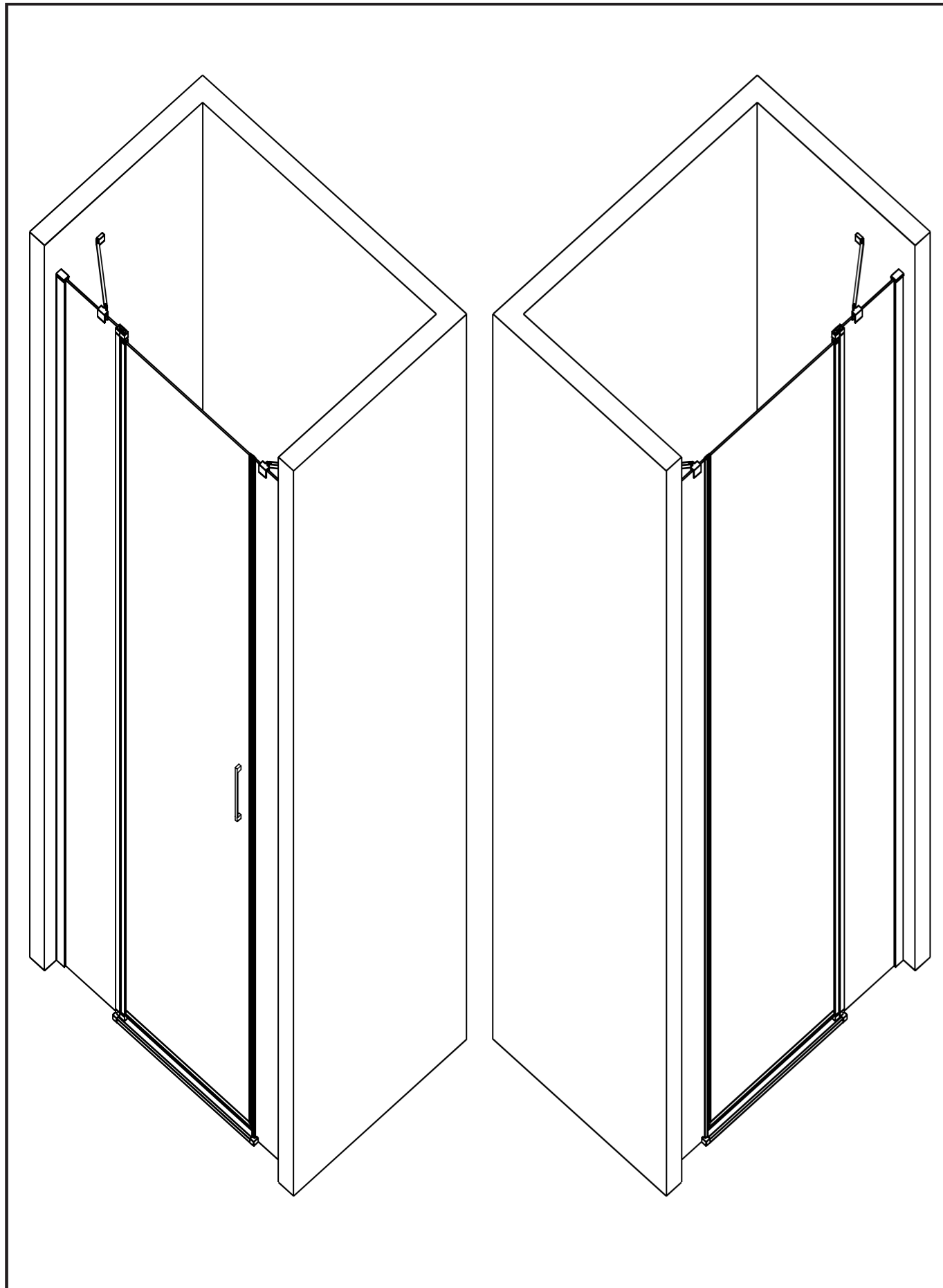

7

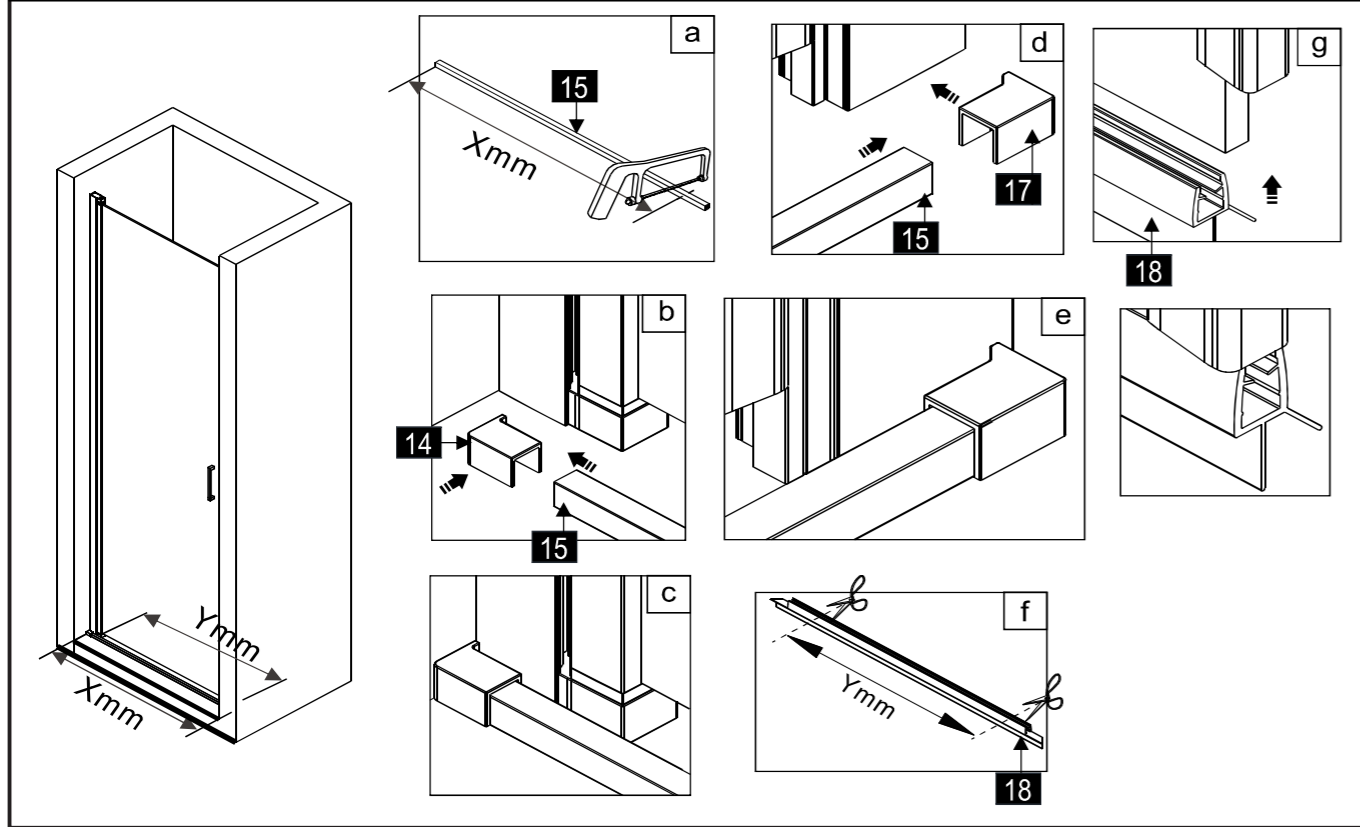

8

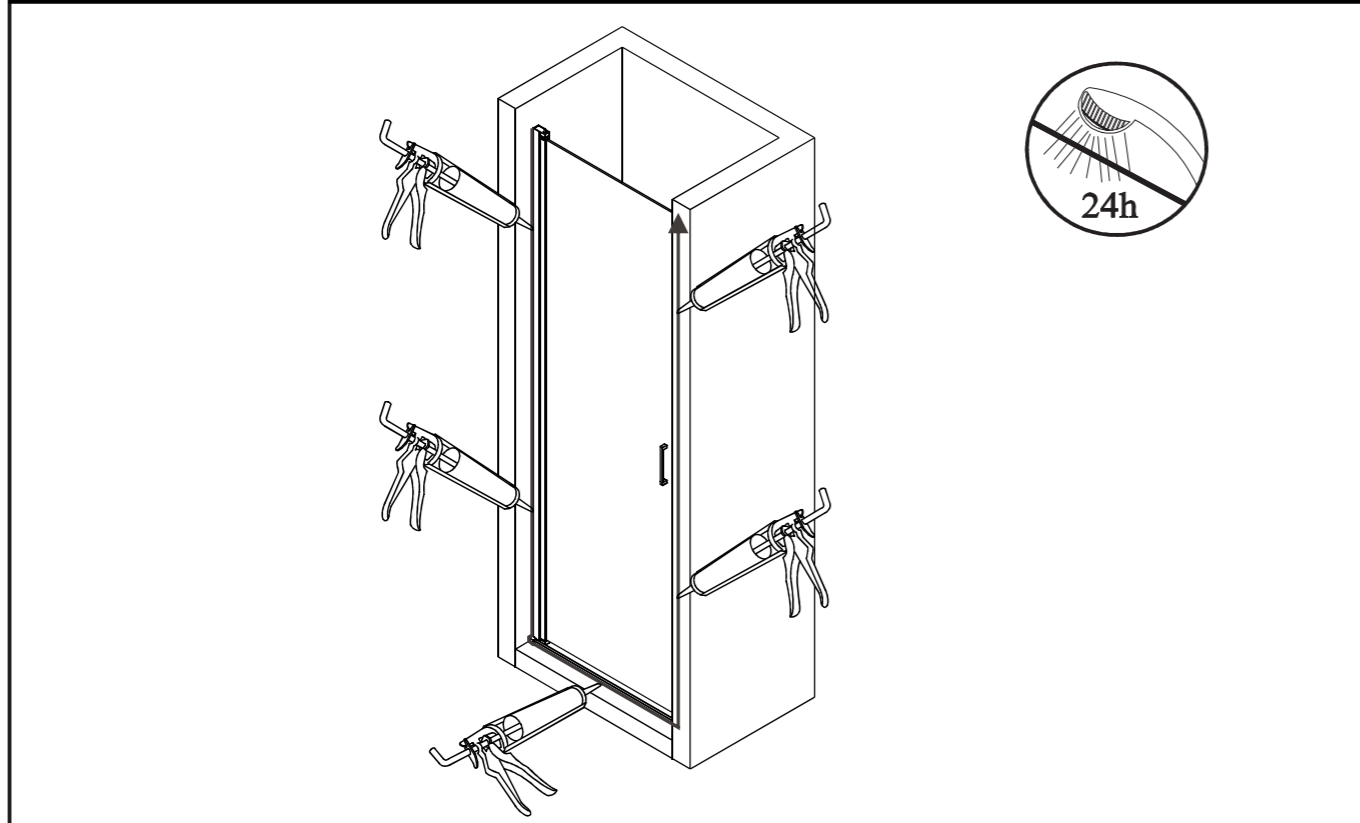

34

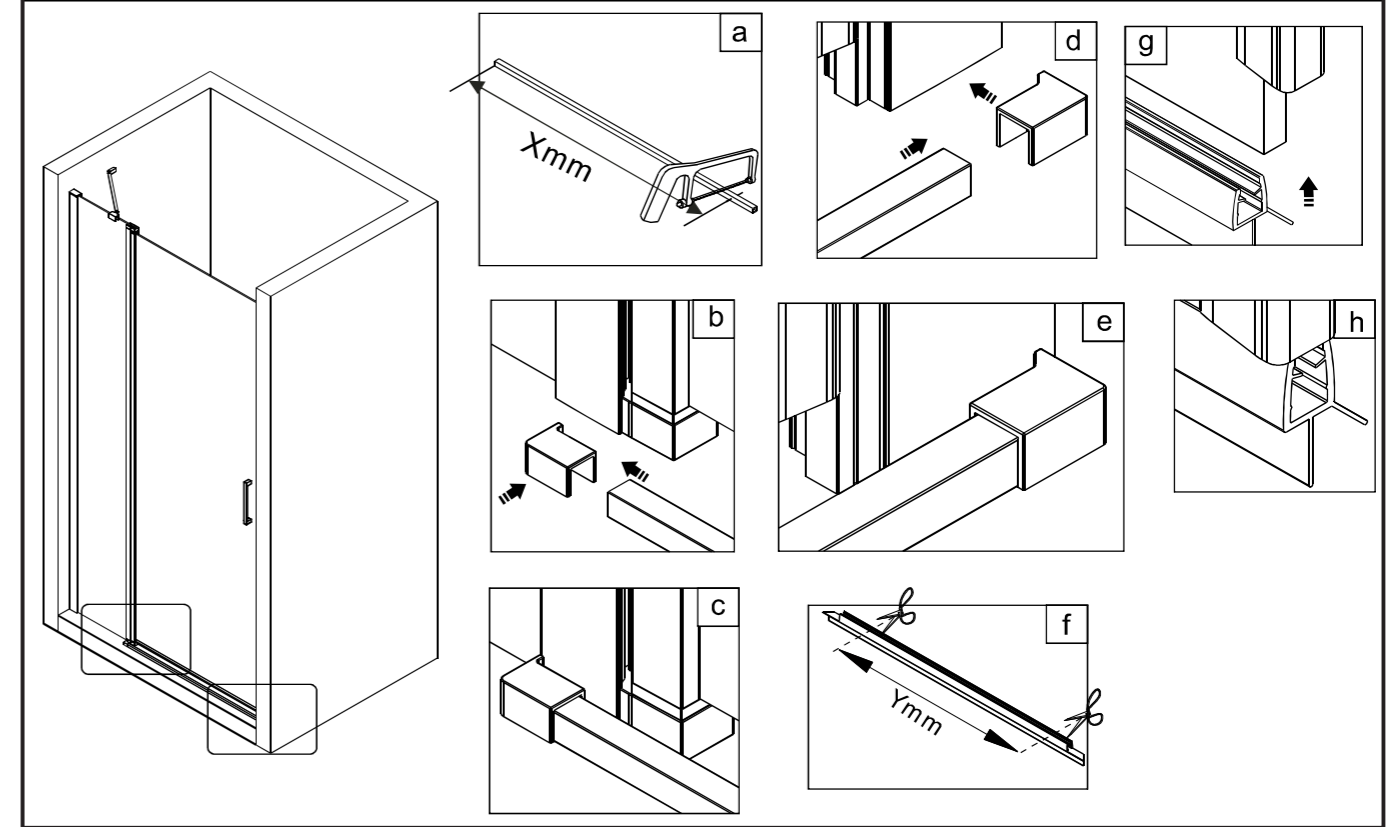

35

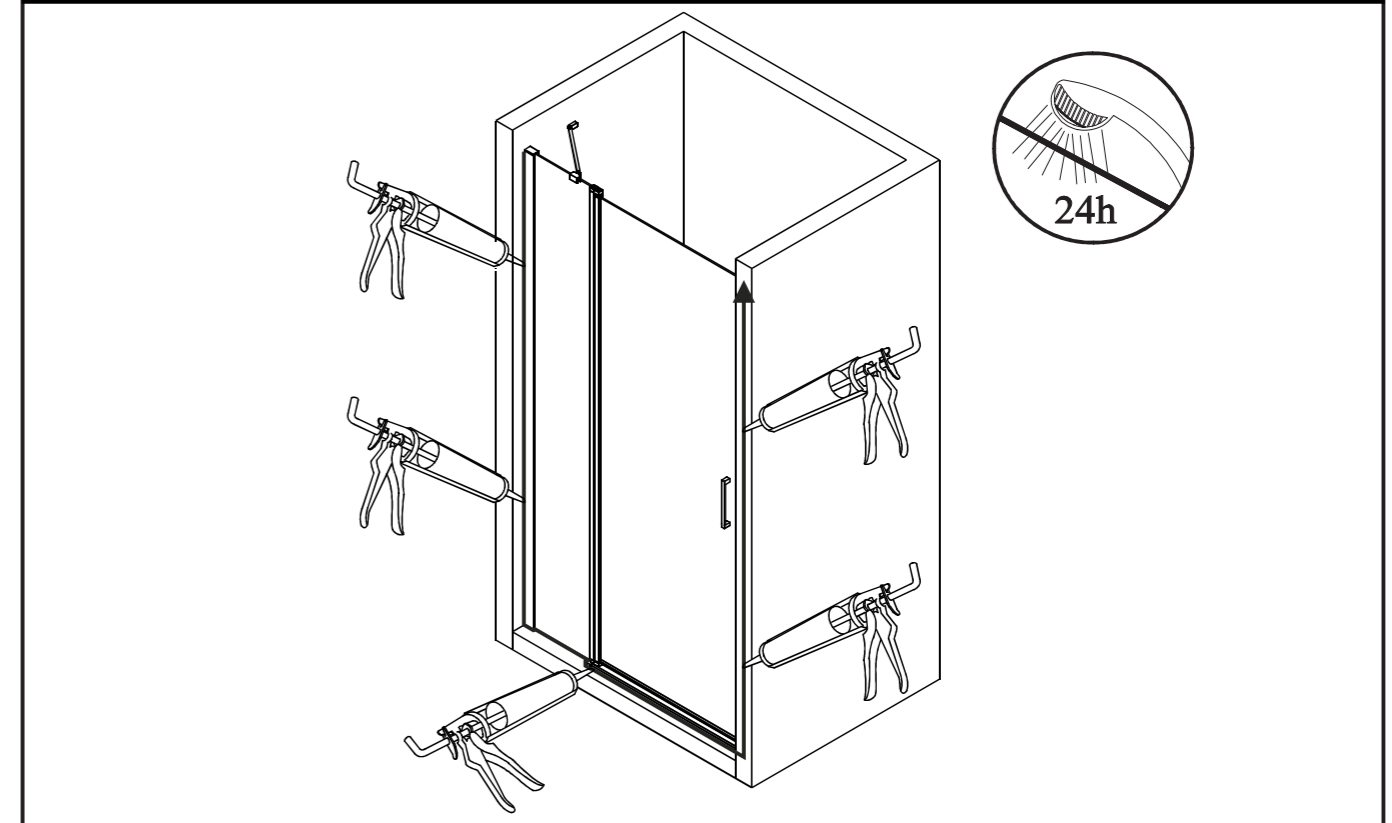

32

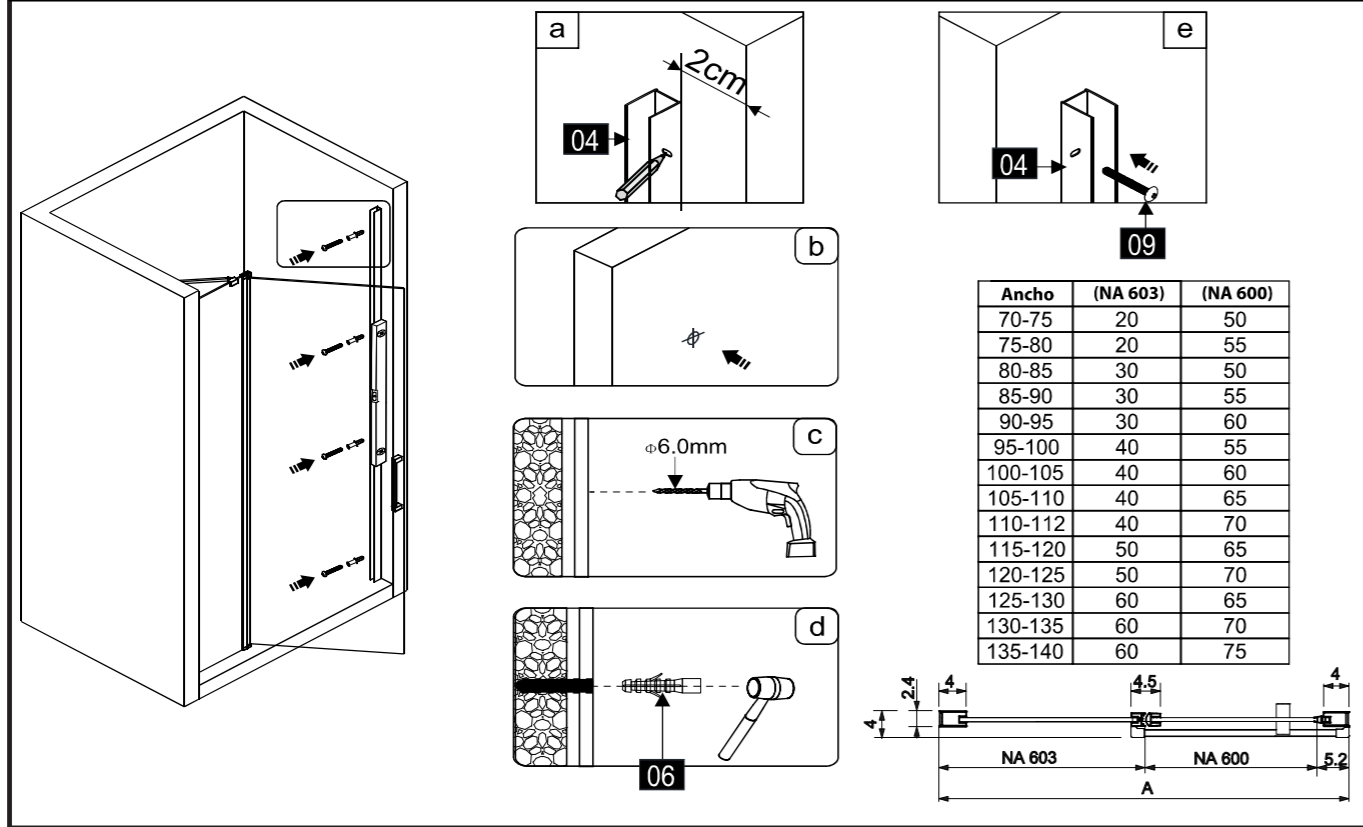

33

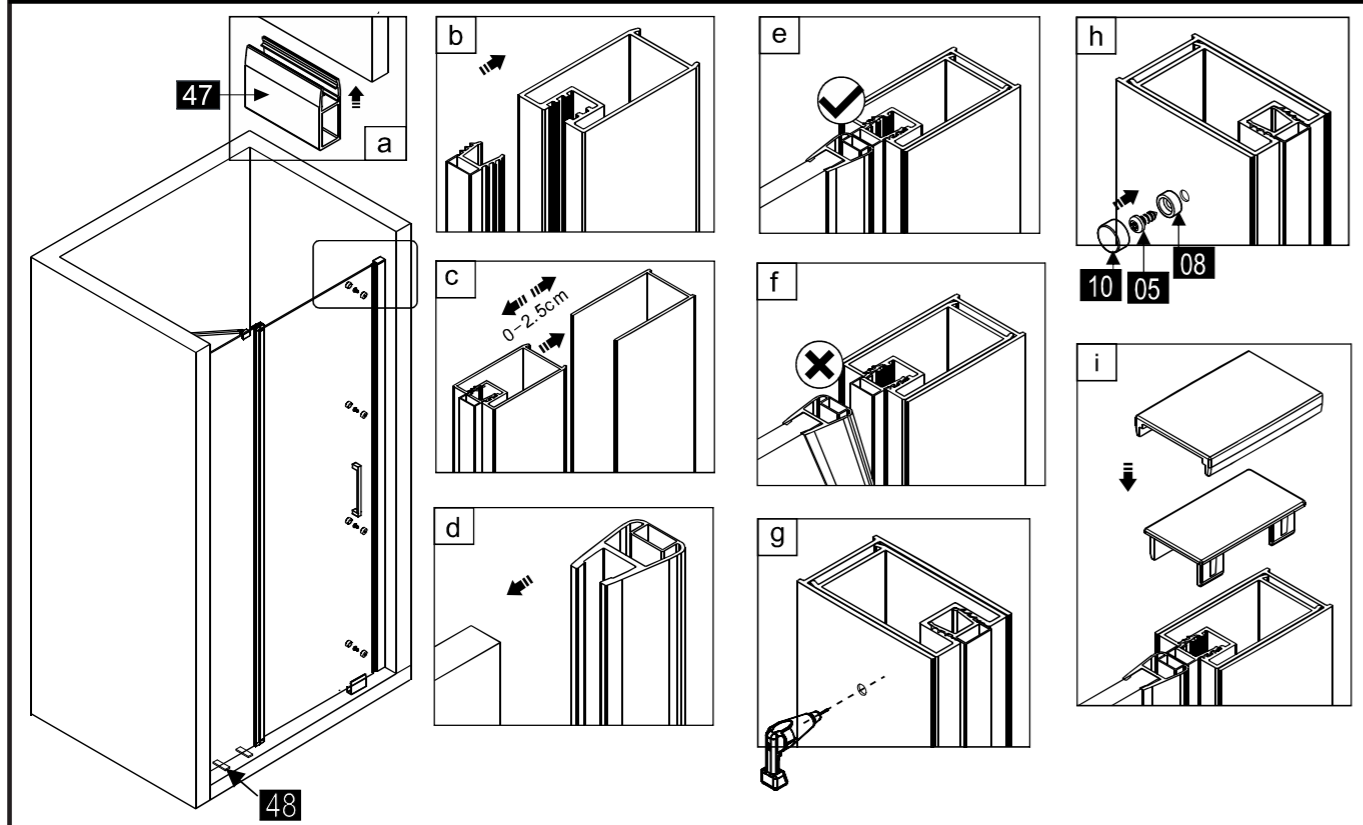

ES INSTRUCCIONES DE MONTAJE
GB INSTALLATION INSTRUCTIONS

FR INSTRUCTIONS D'INSTALLATION
DE MONTAGEANLEITUNG

ESQUEMA/SCHEME/SCHÉMA/SCHEMA

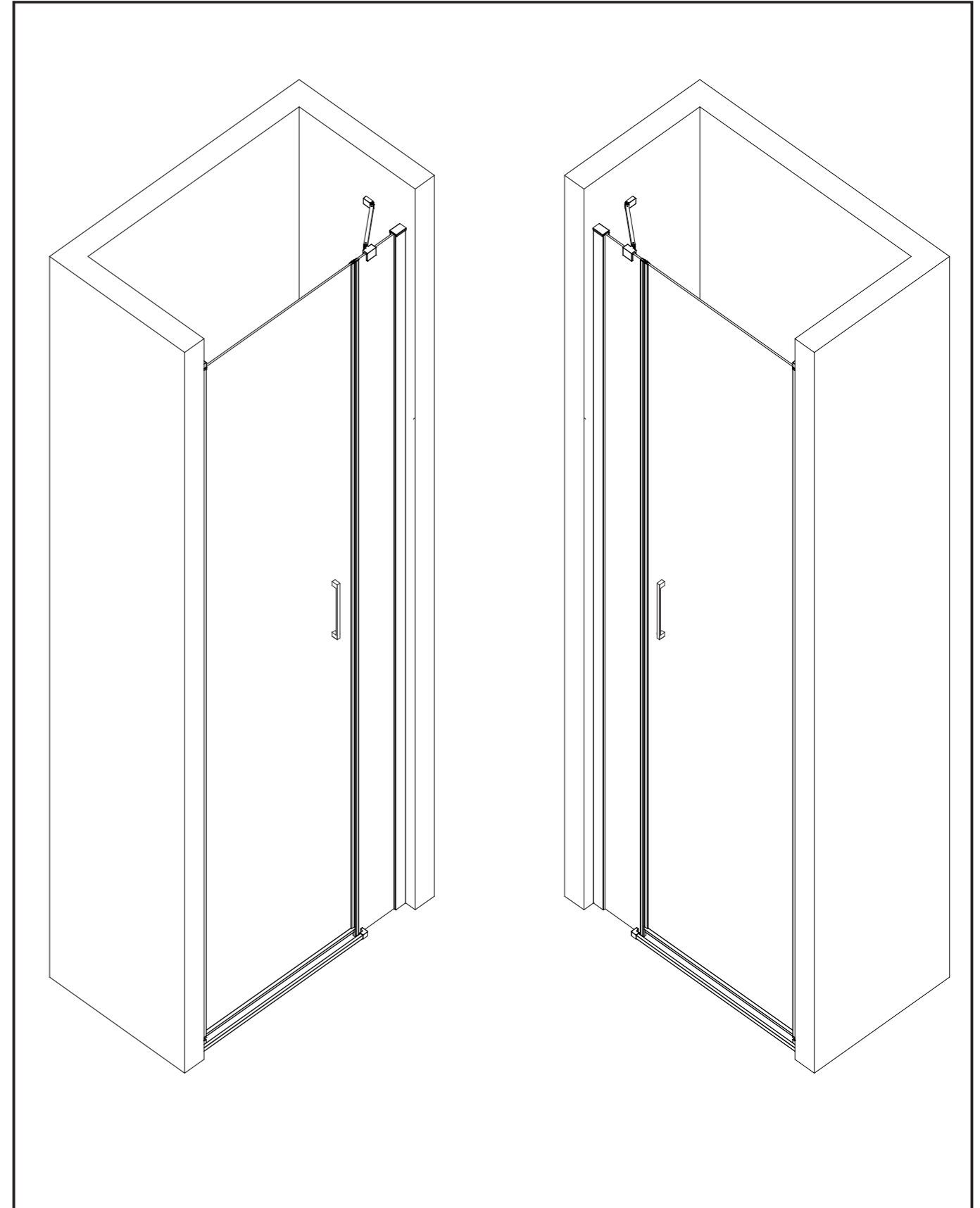

9

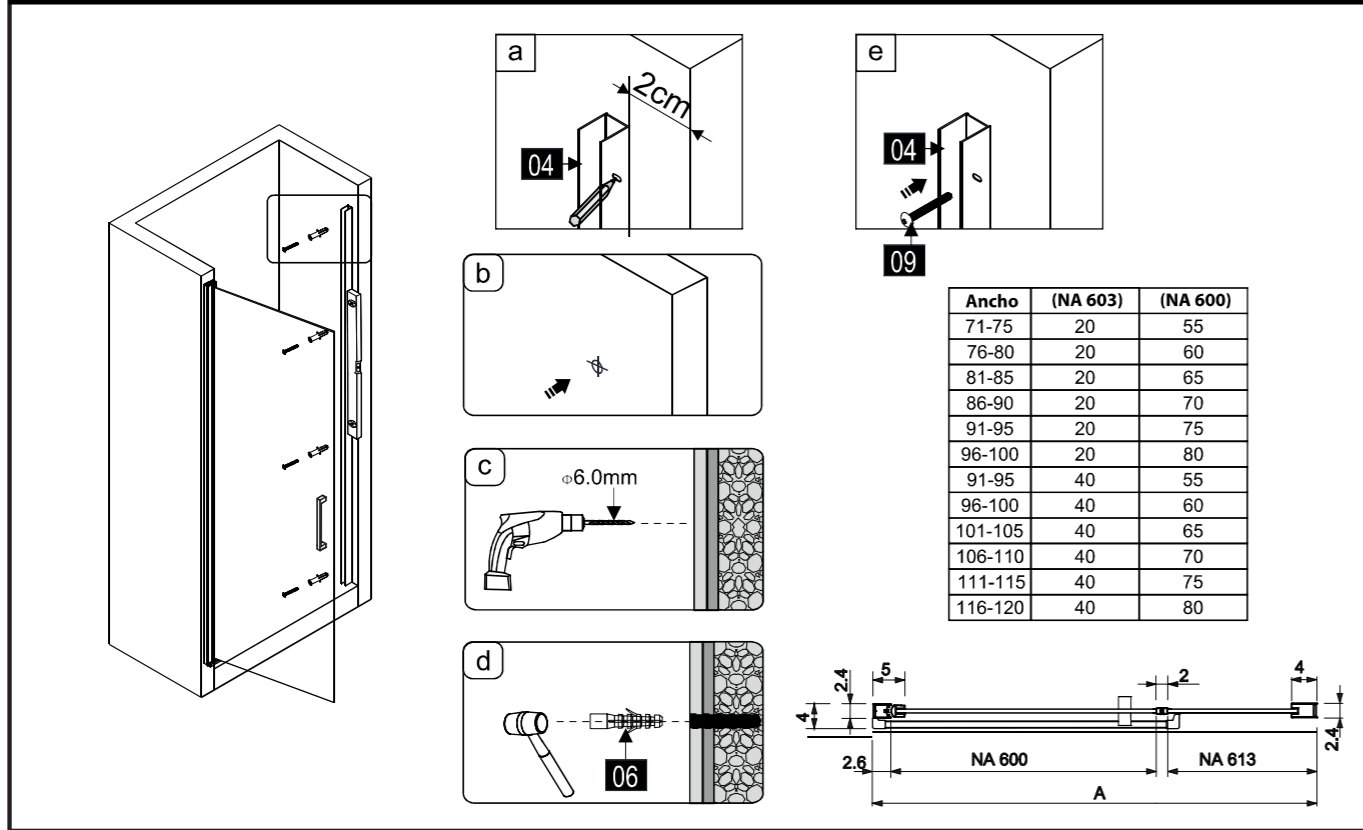

10

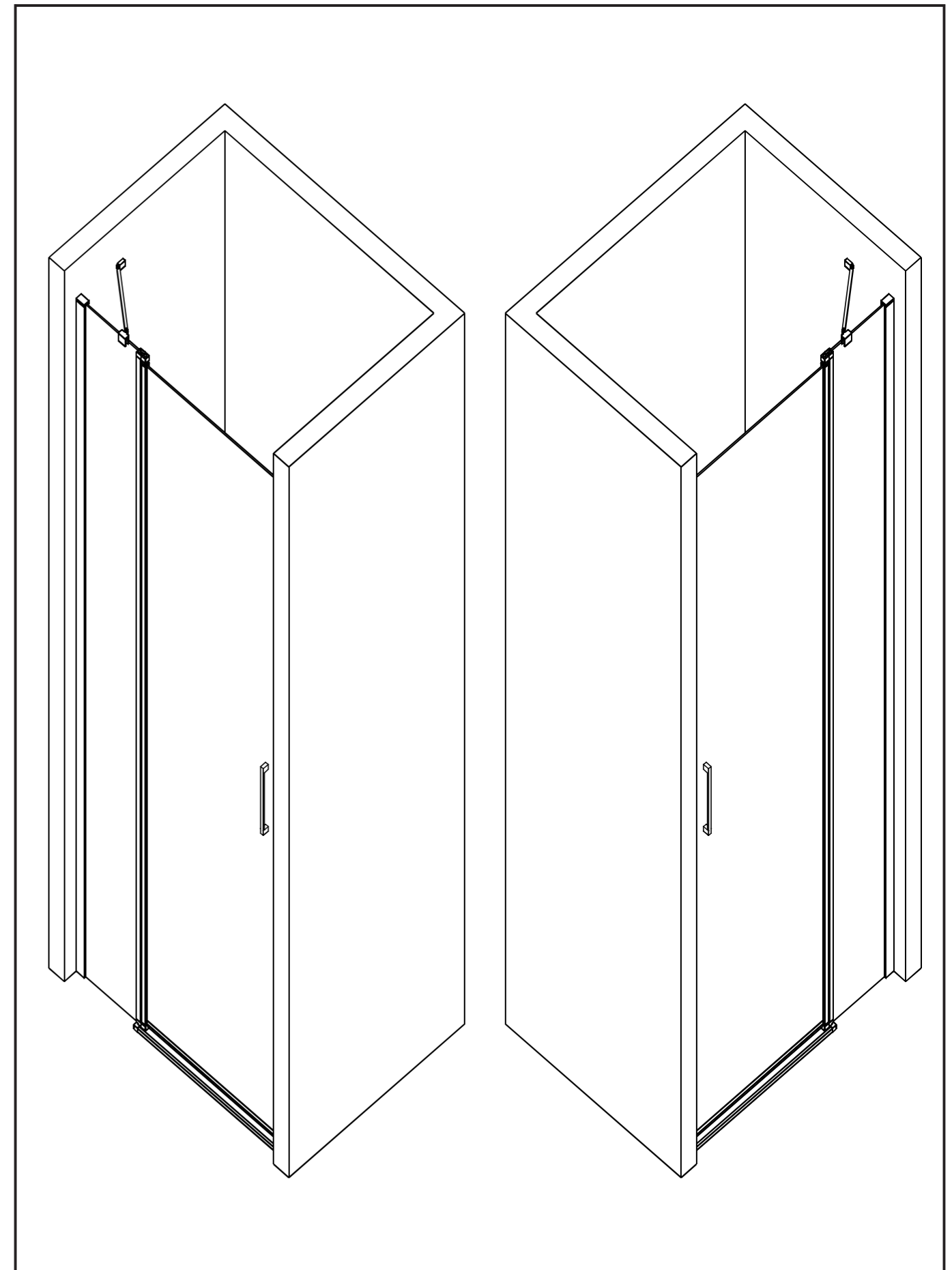
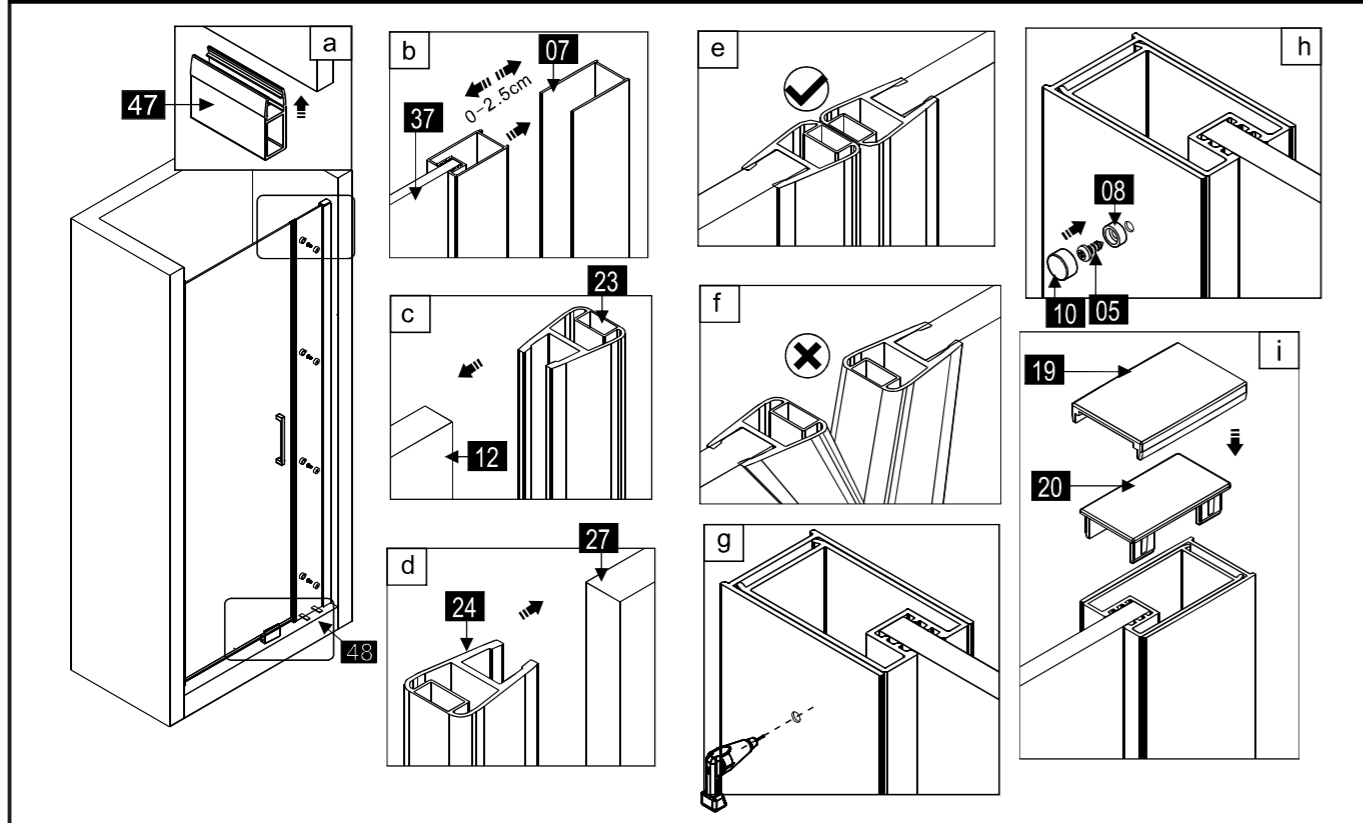

31

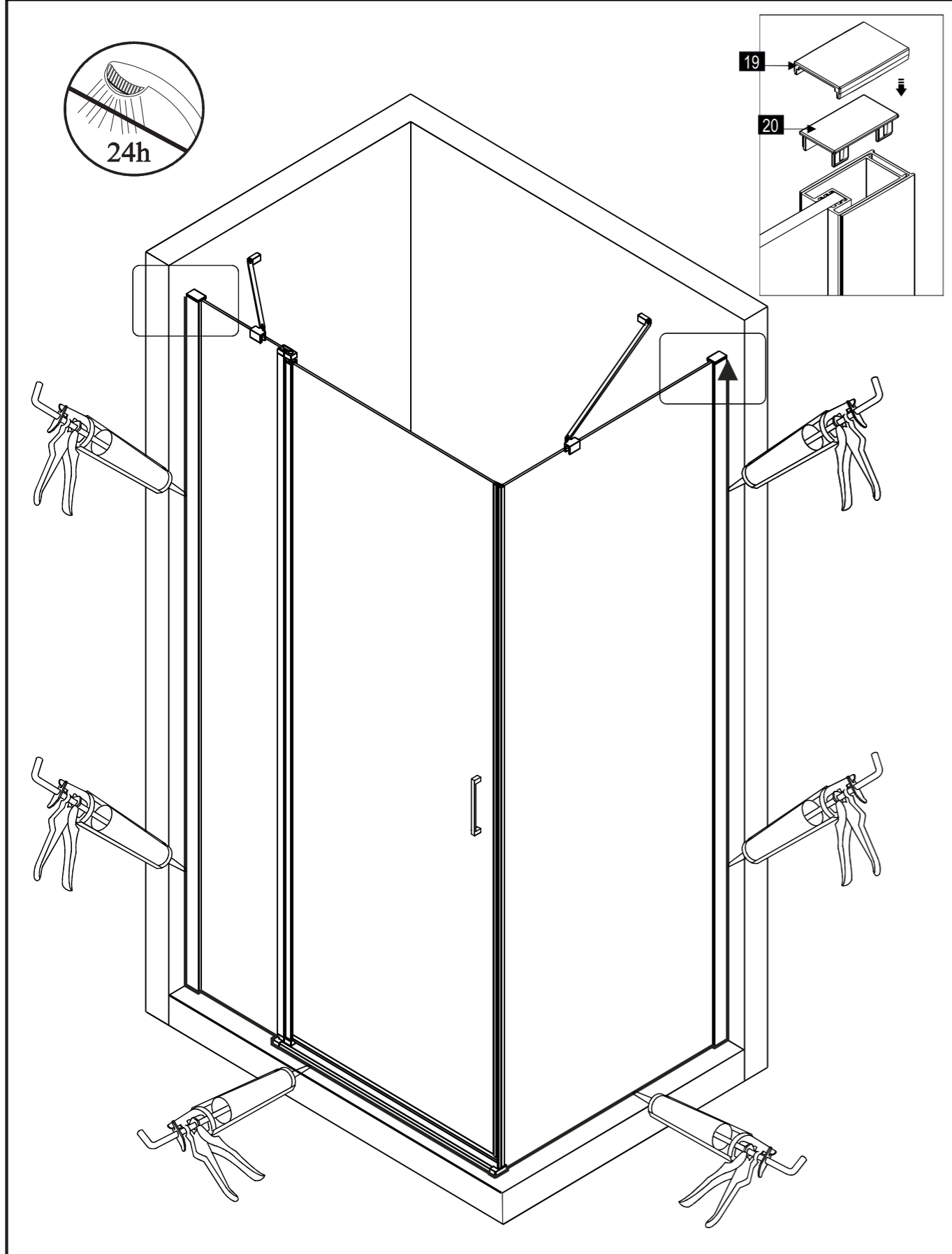

11

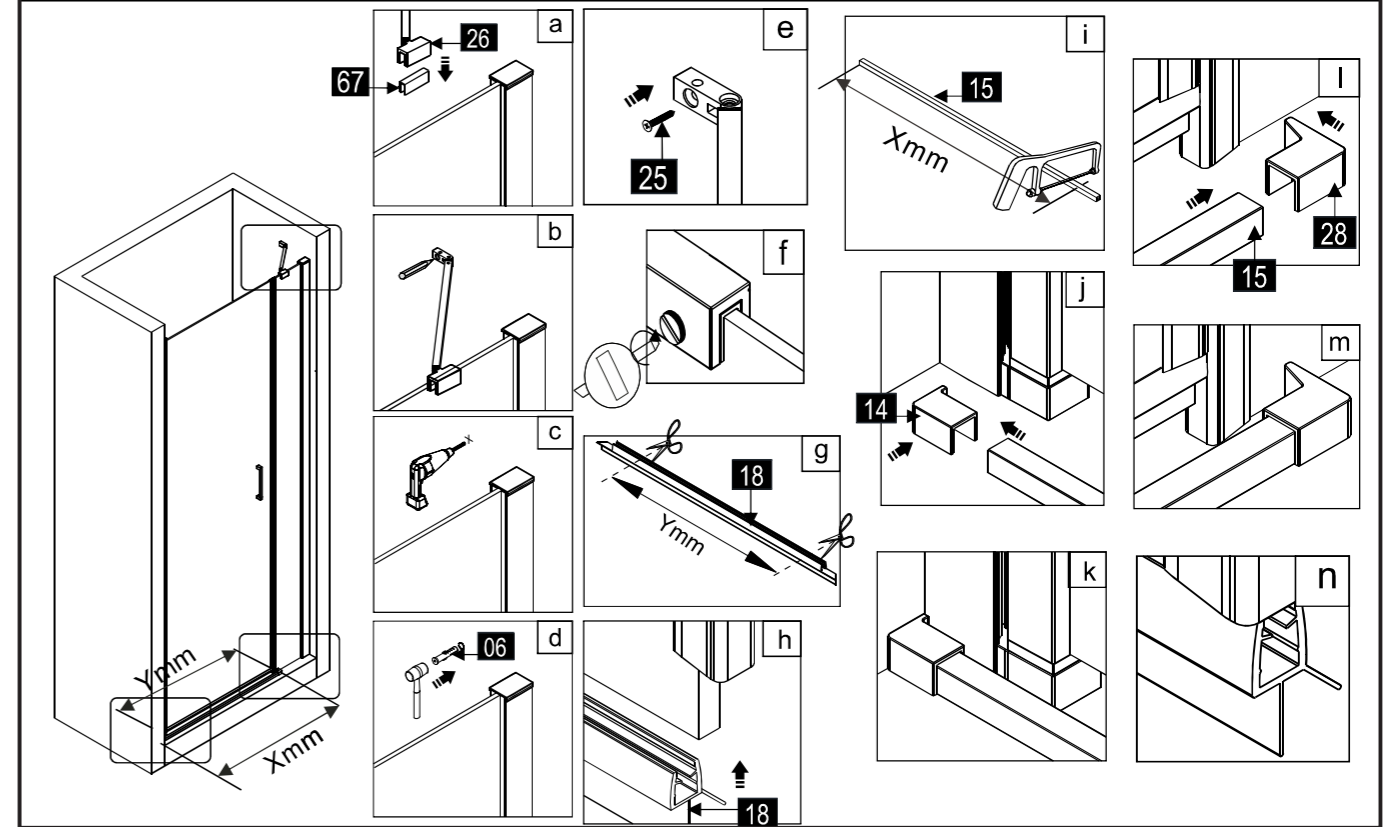

12

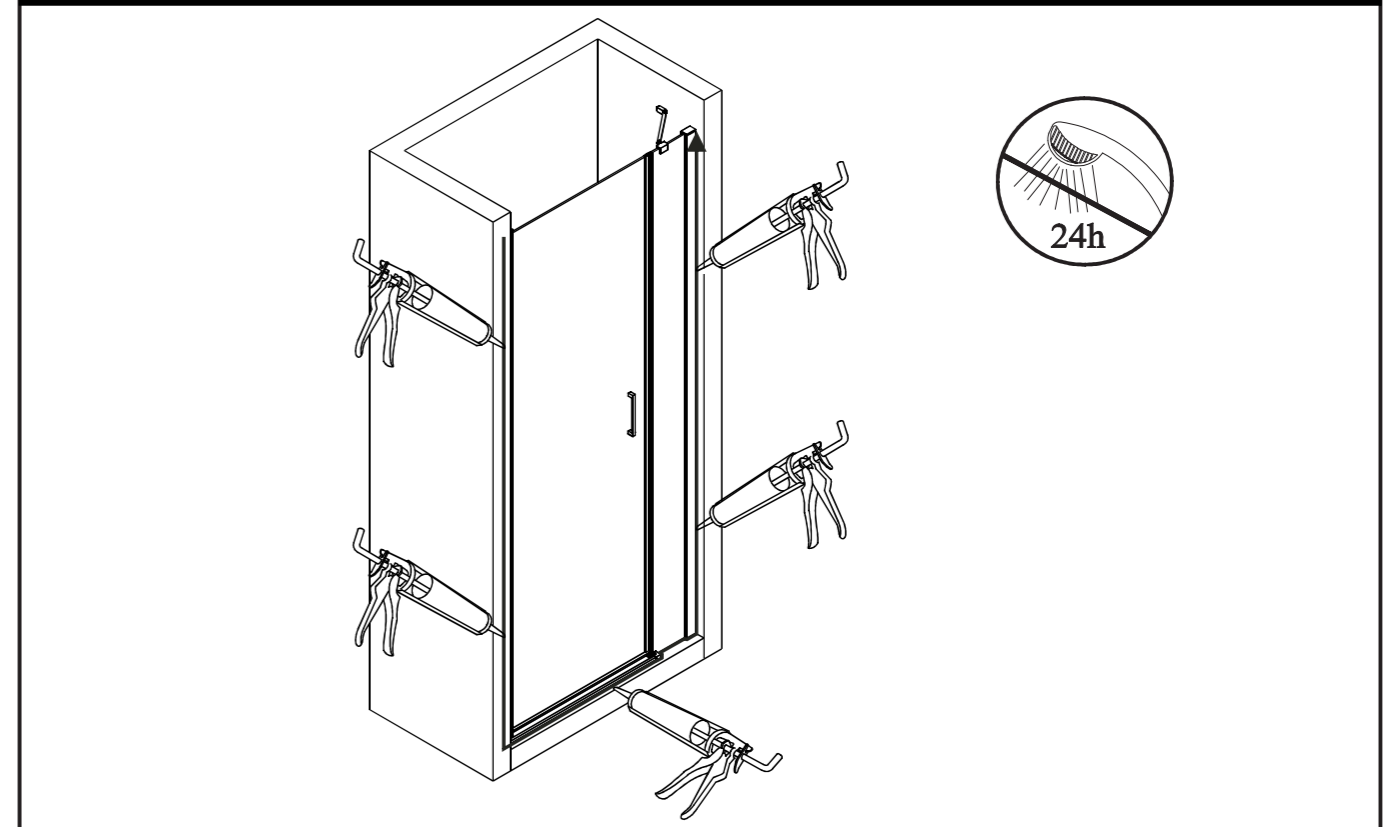

ESQUEMA/SCHEME/SCHEMA/SCHEMA

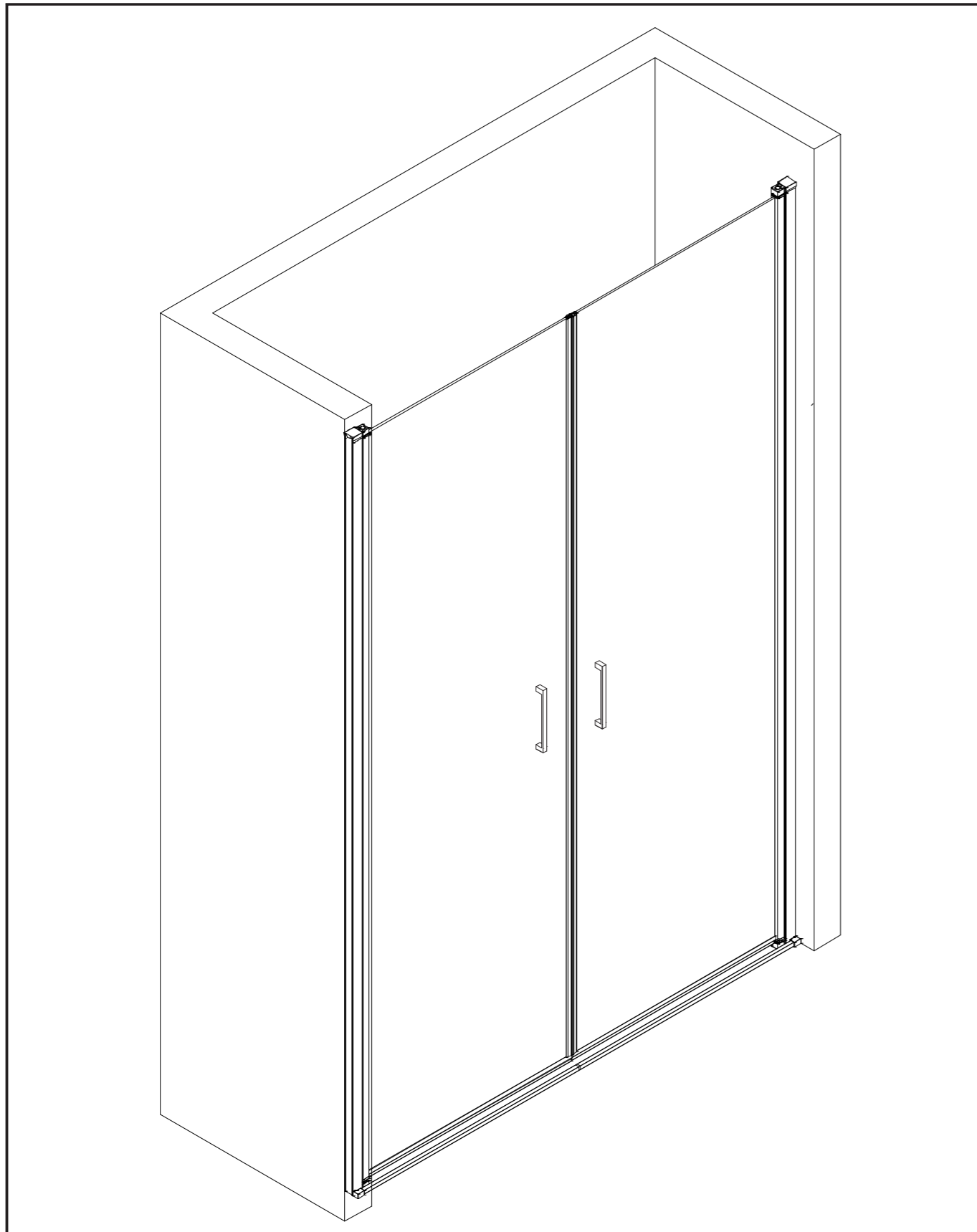

29

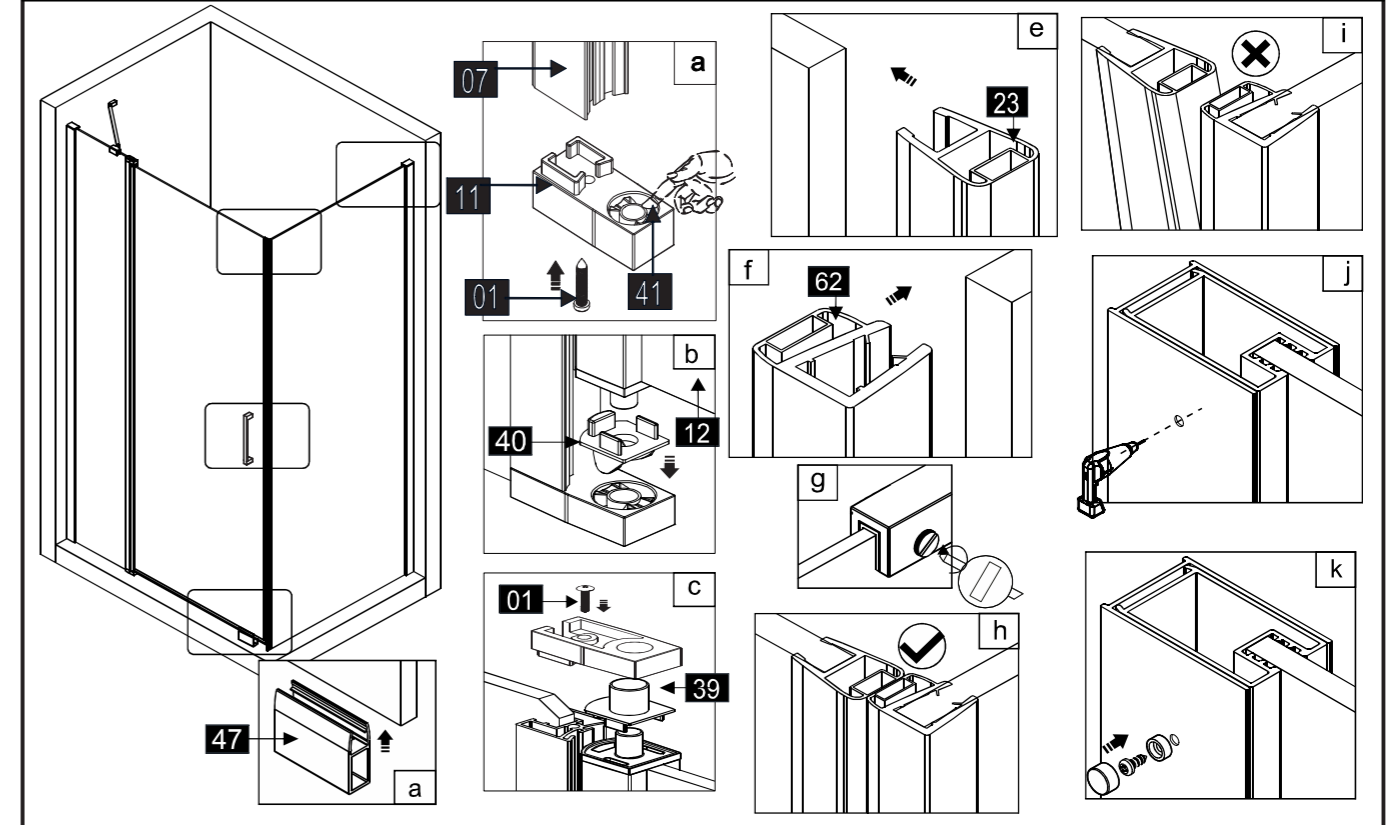

30

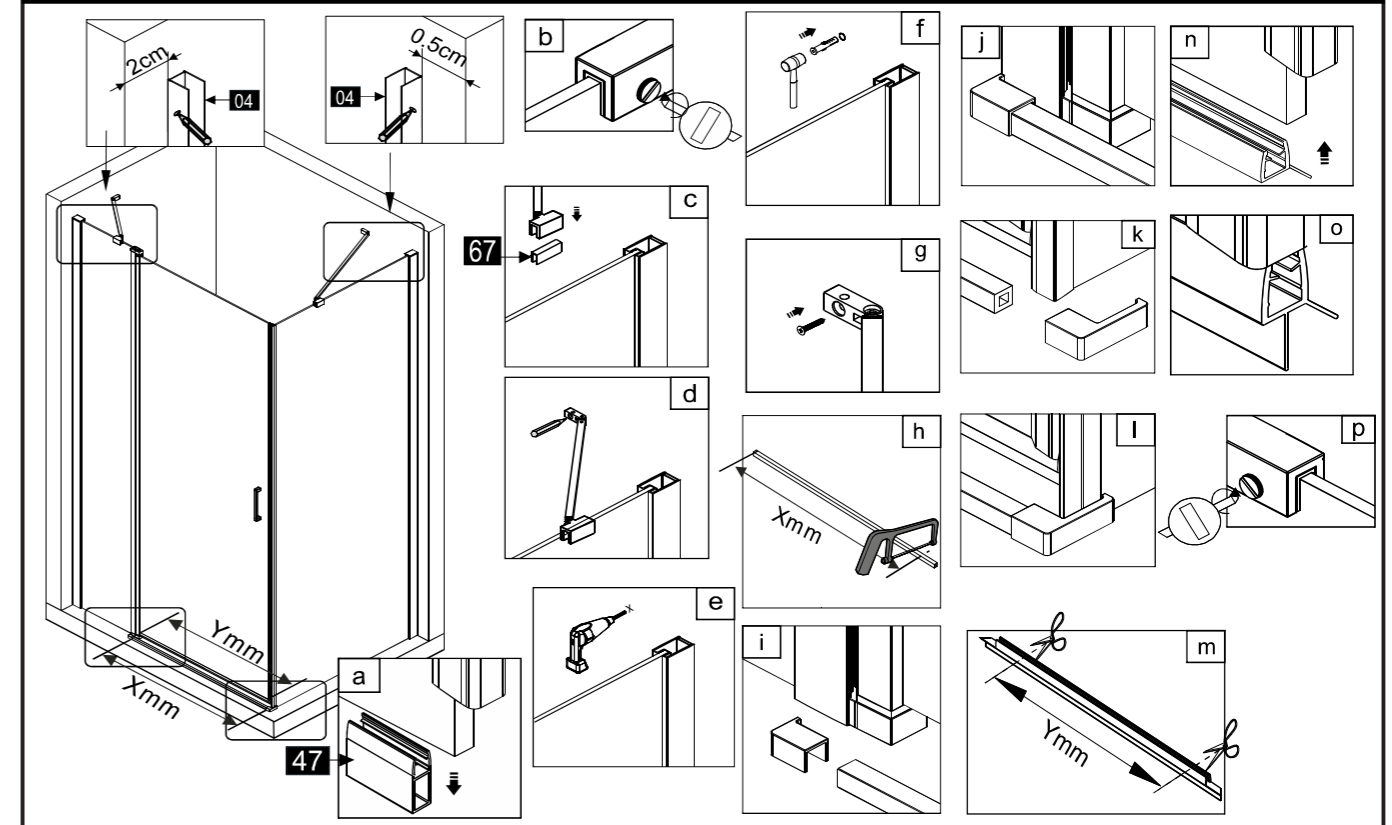

27

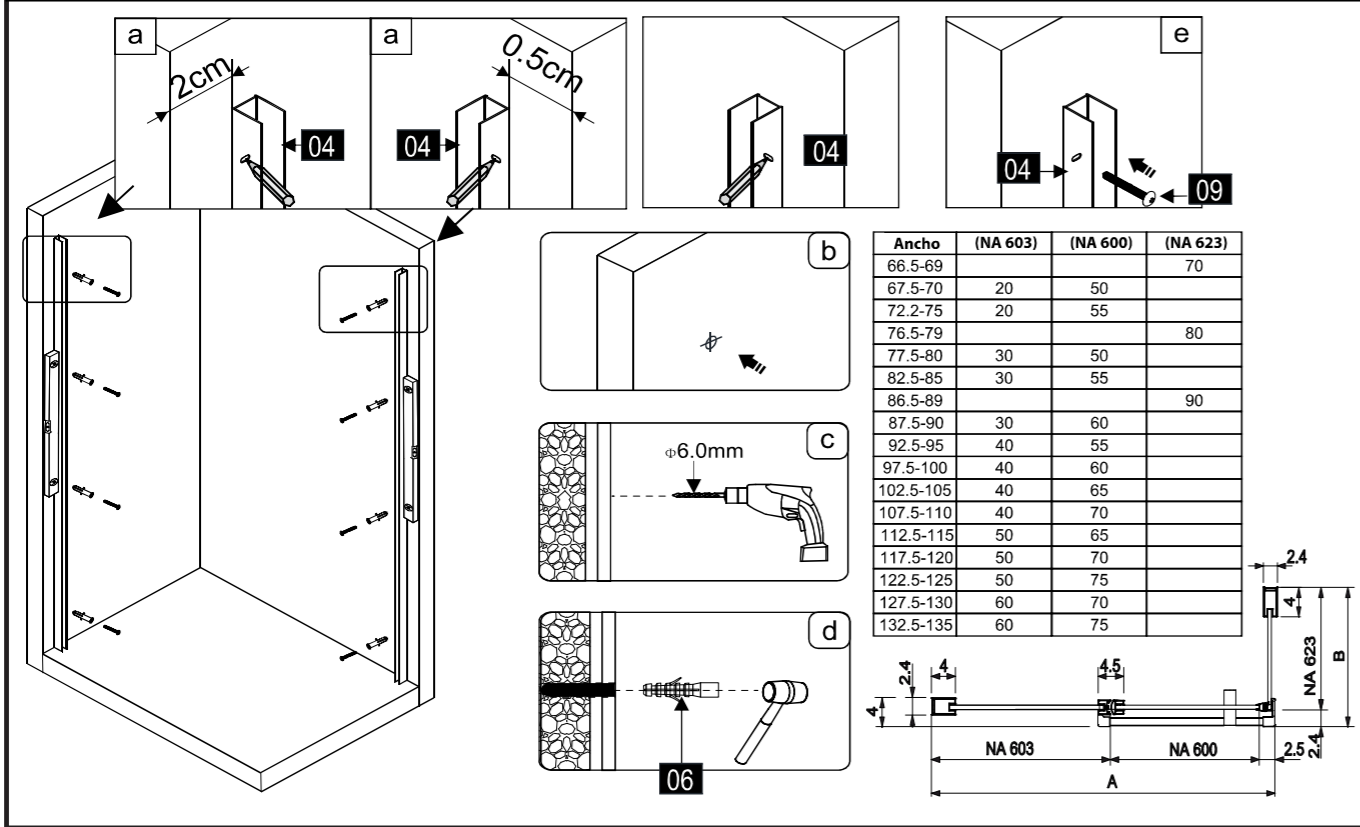

13

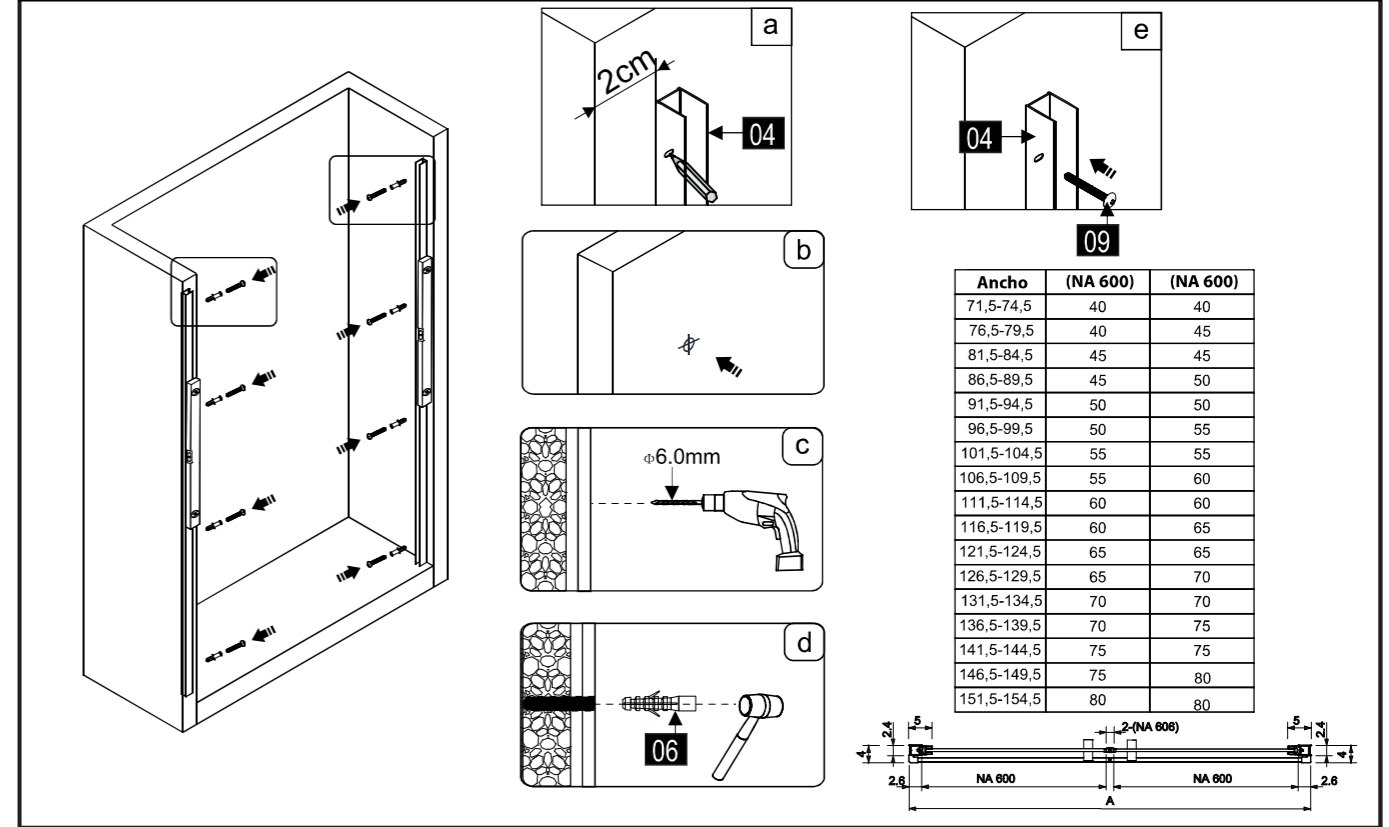

28

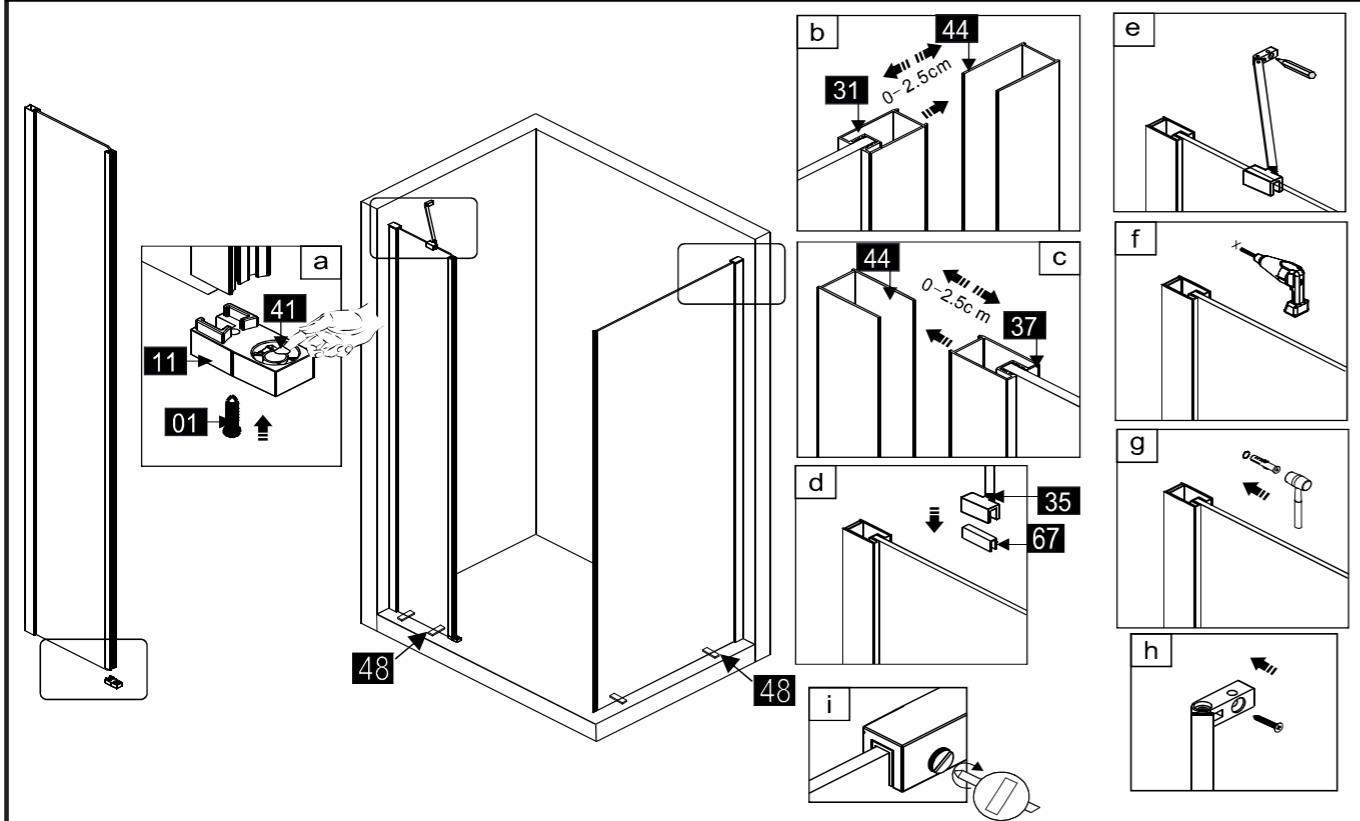

14

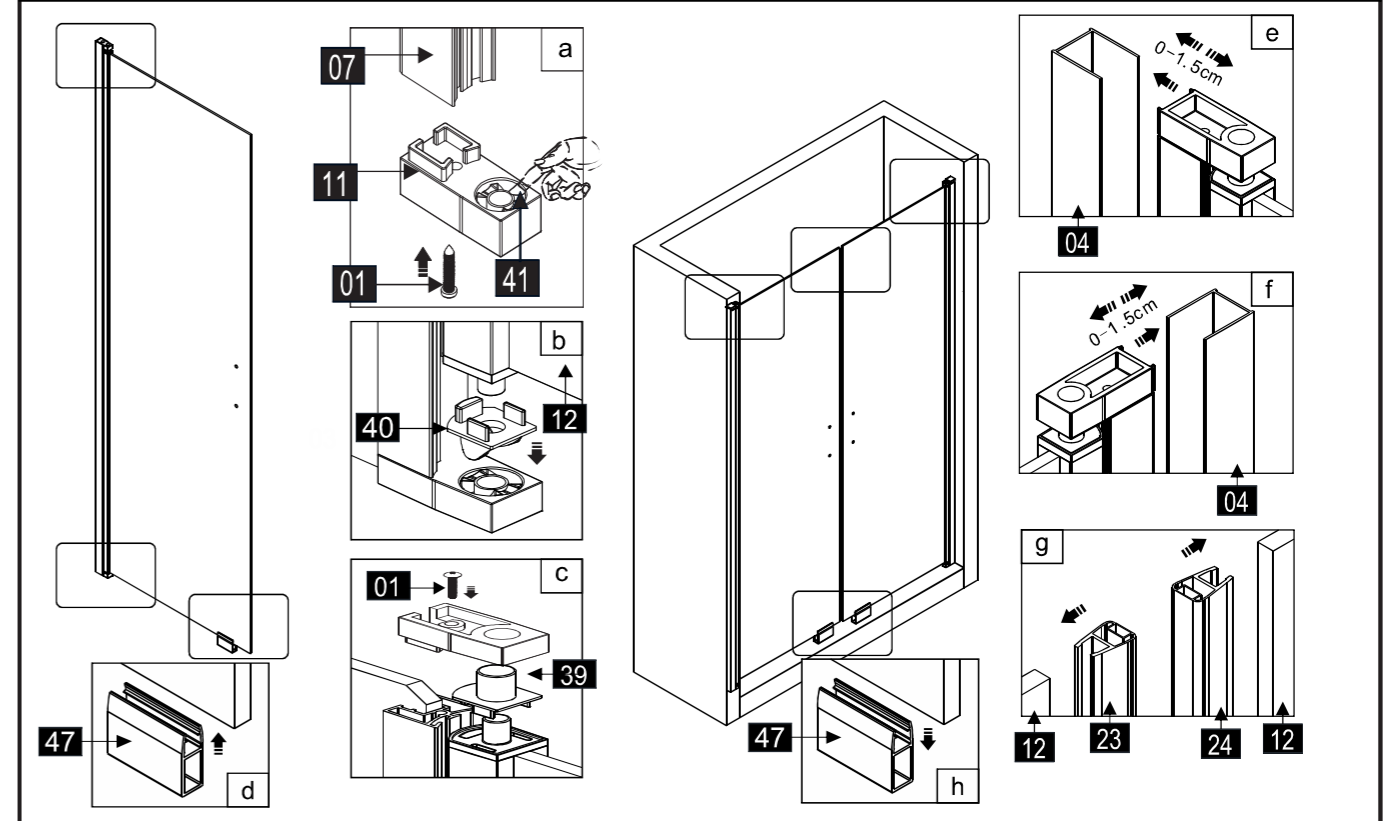

15

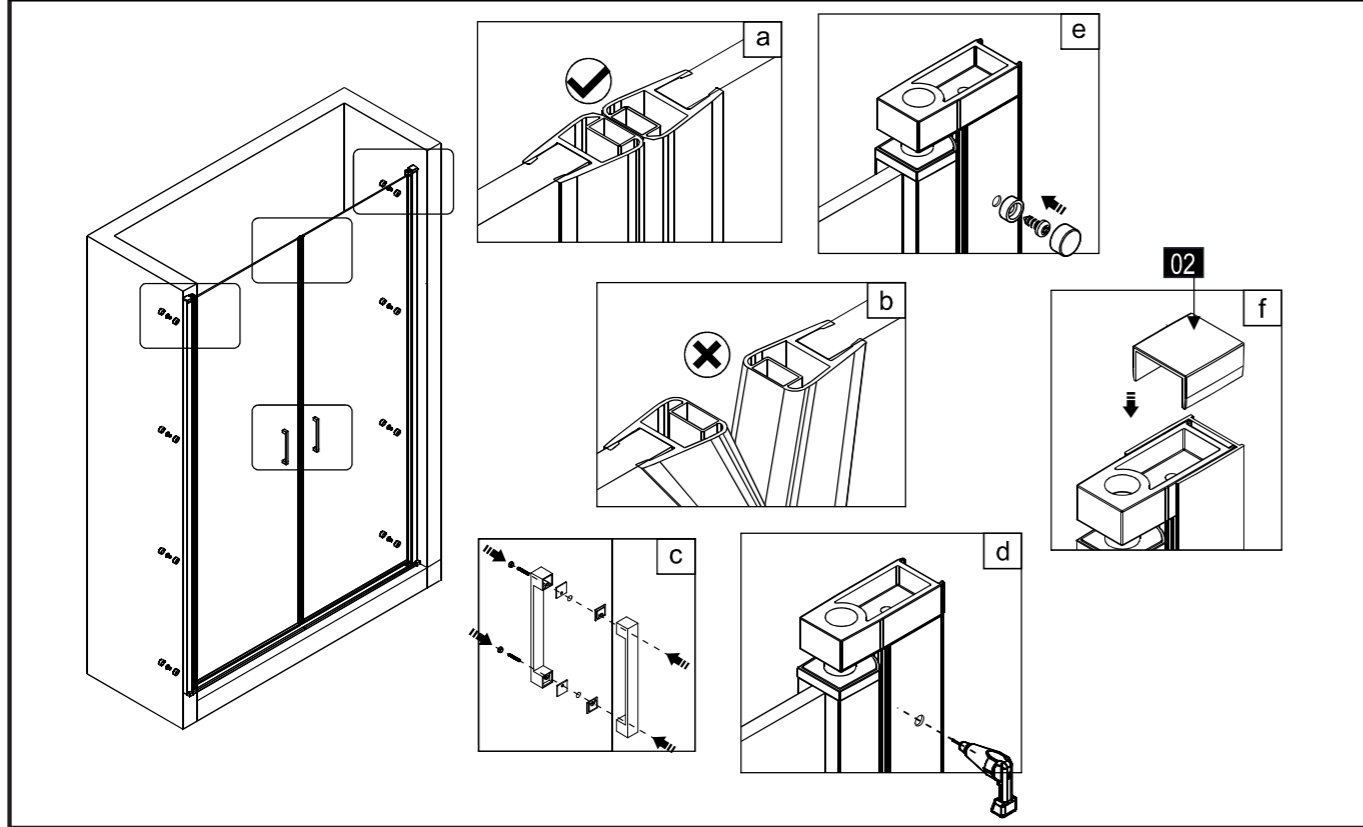

16

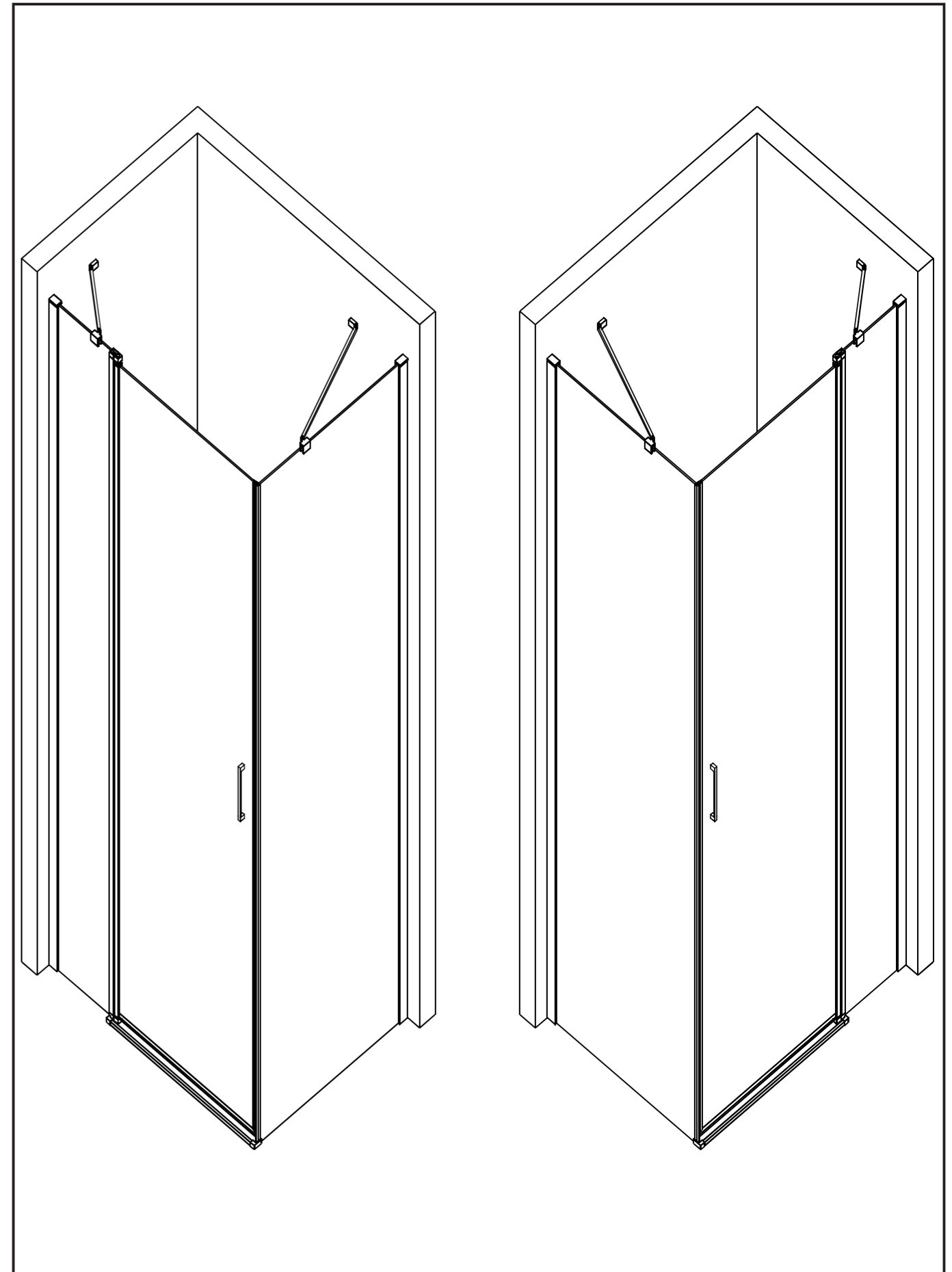
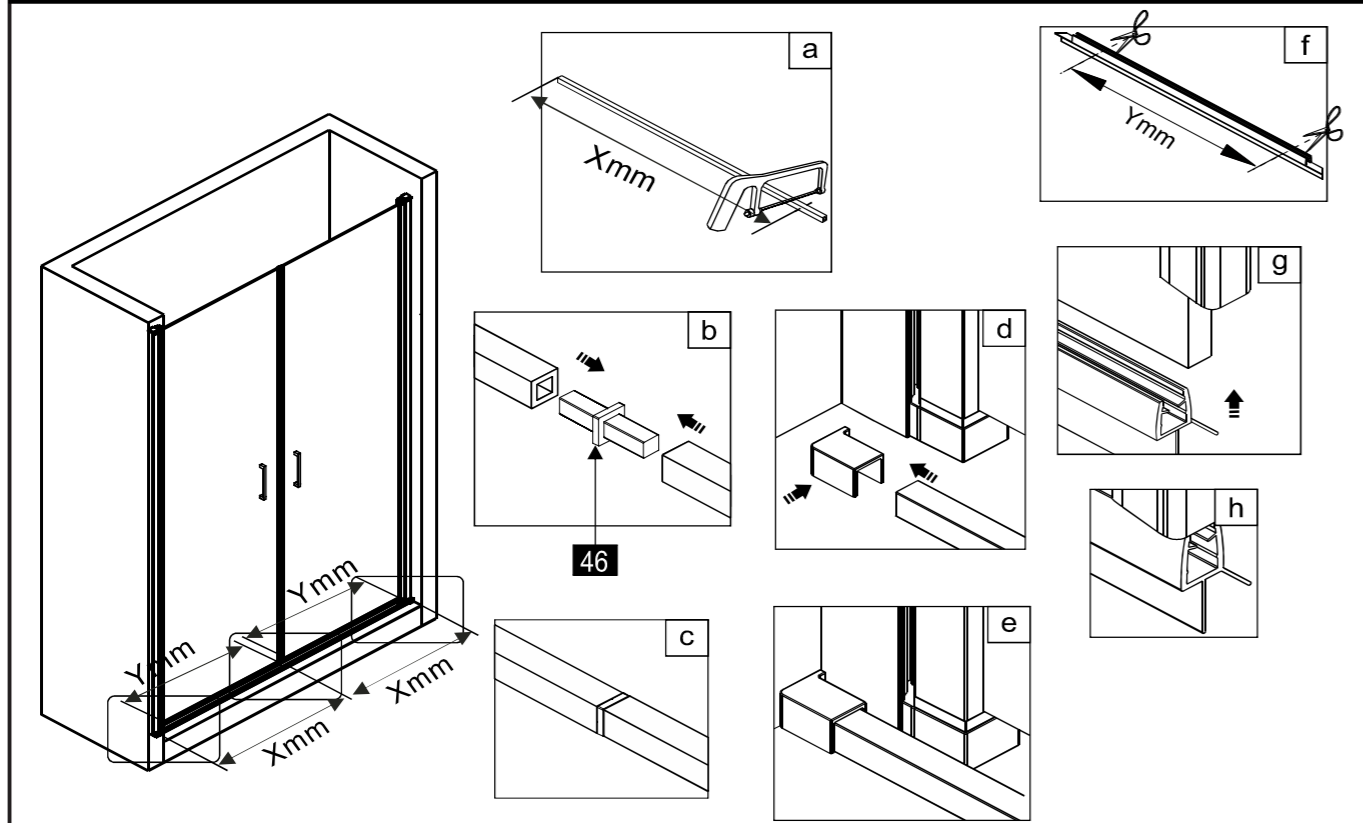

25

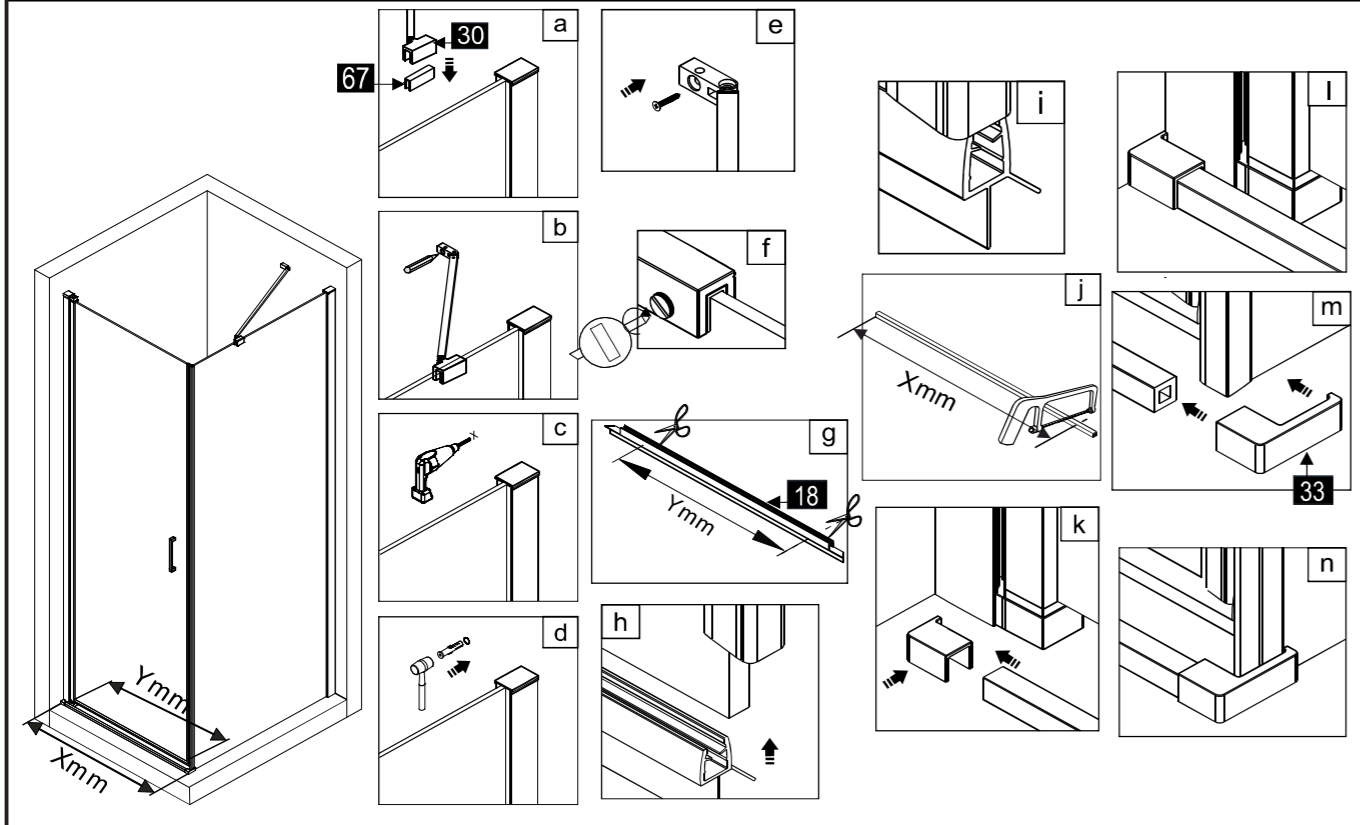

26

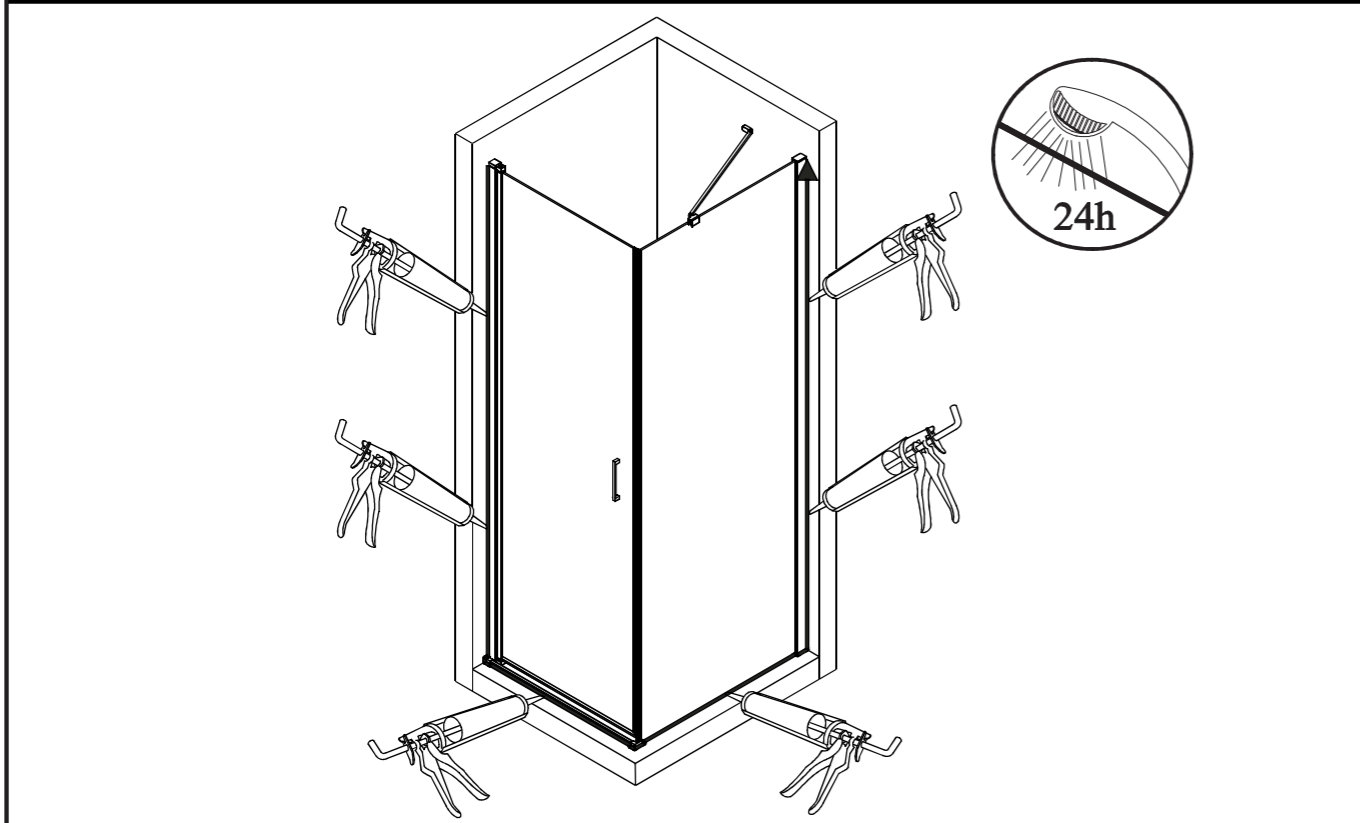

17

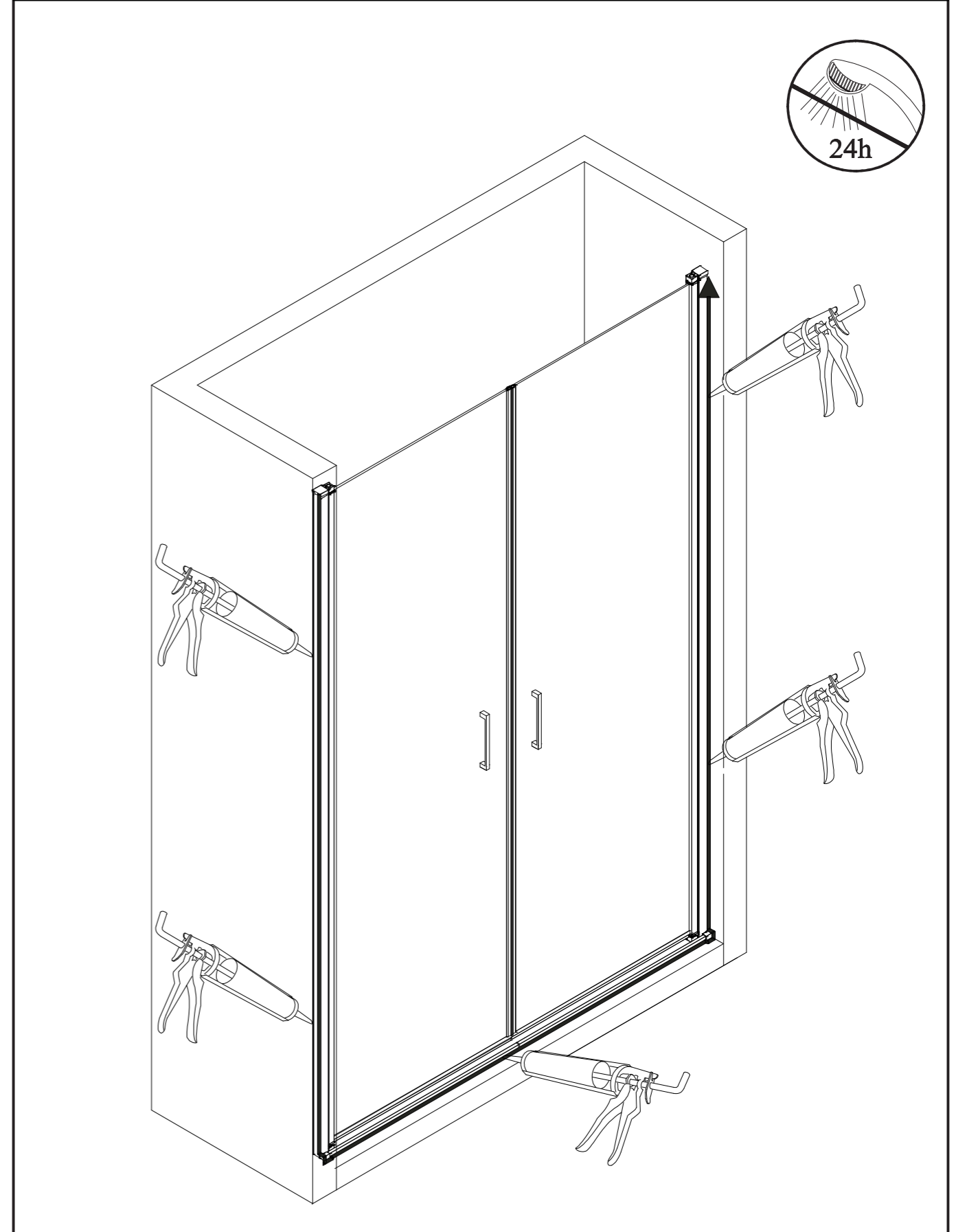

ESQUEMA/SCHEME/SCHEMA/SCHEMA

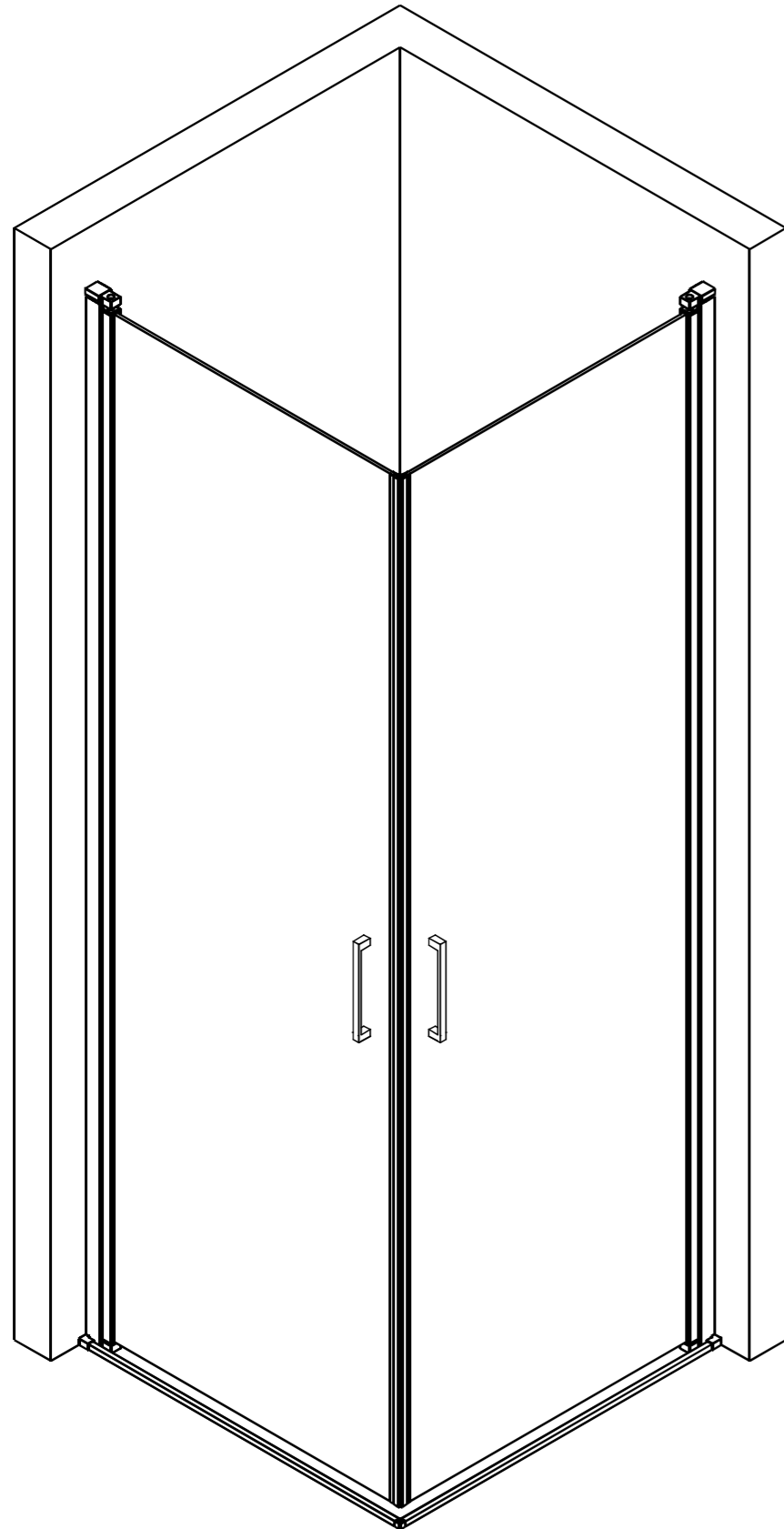

23

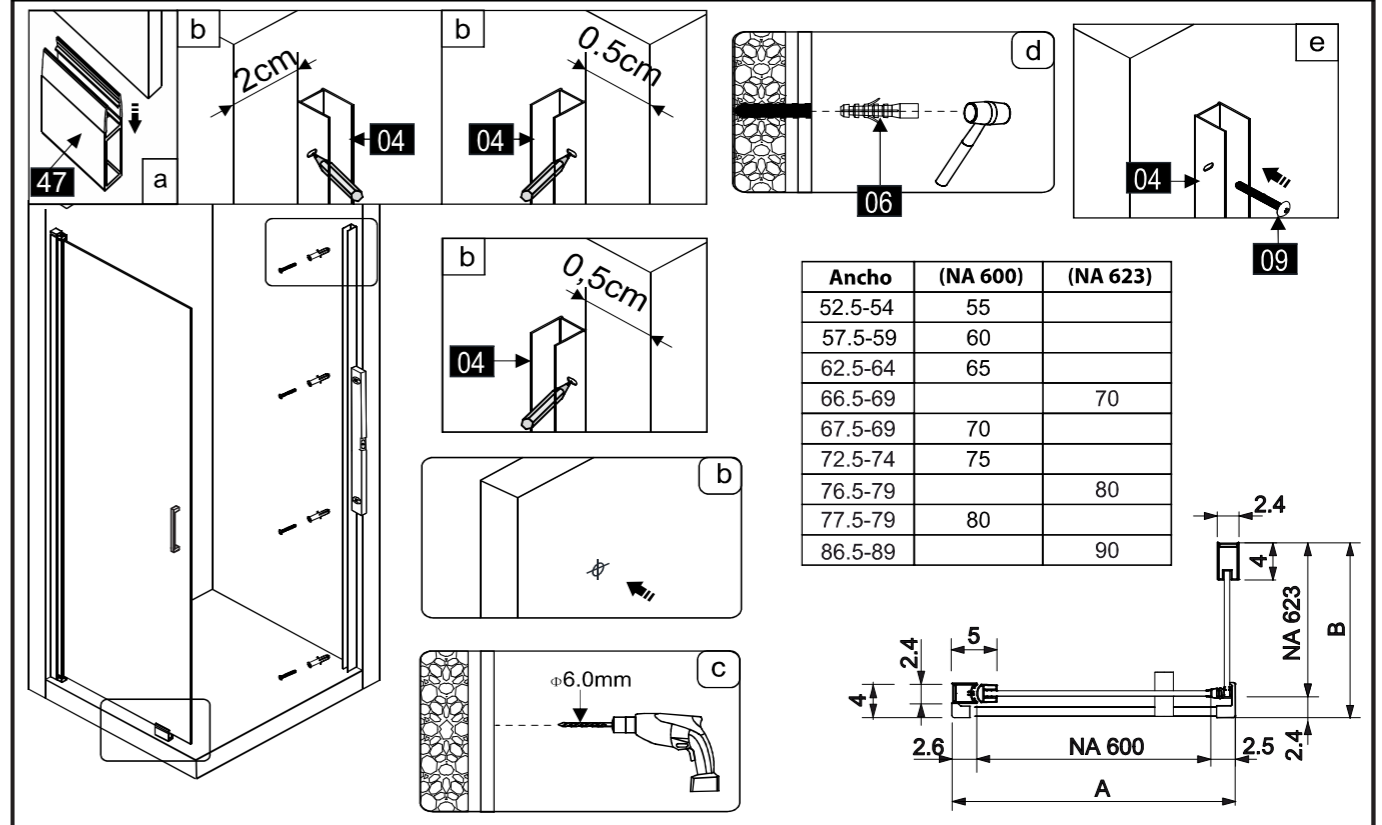

24

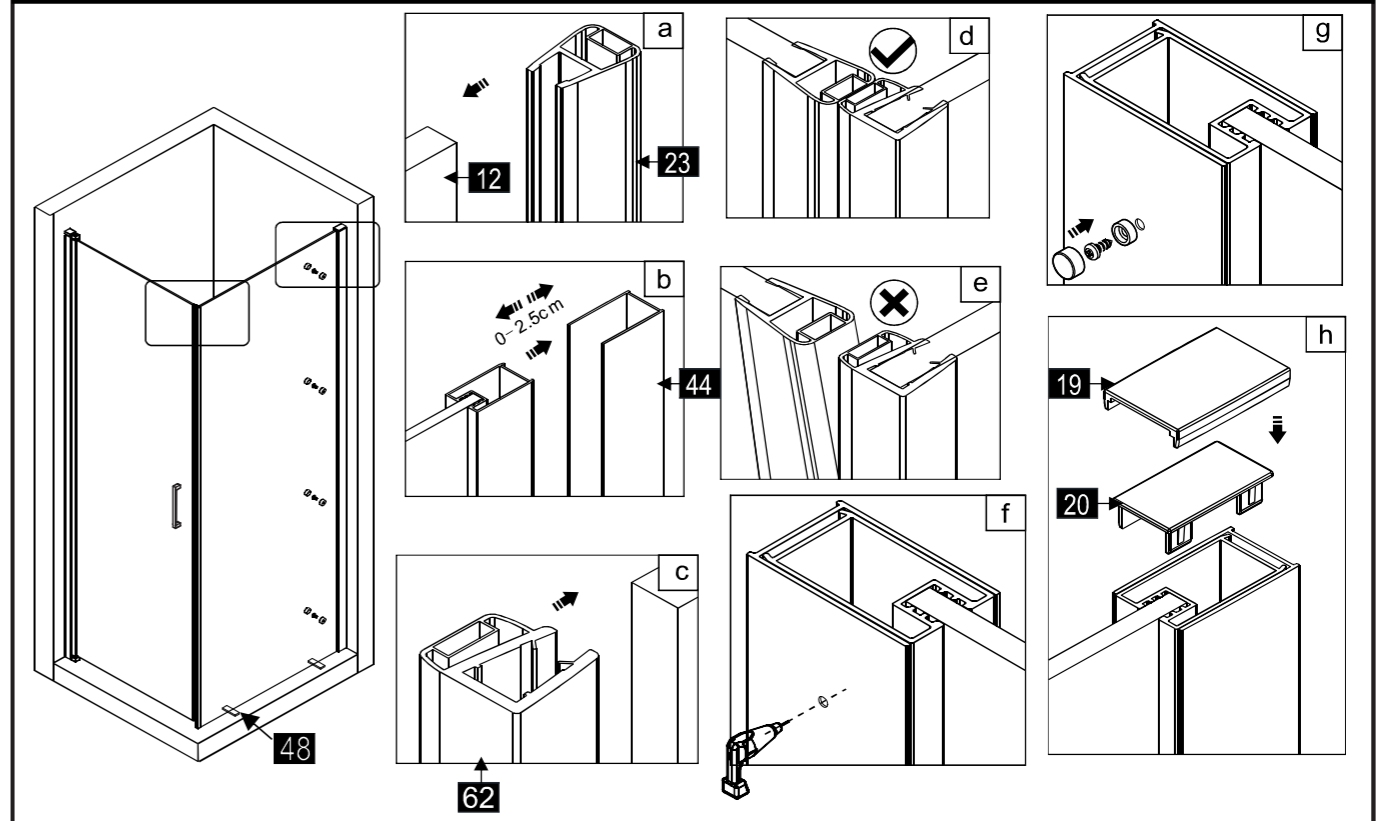

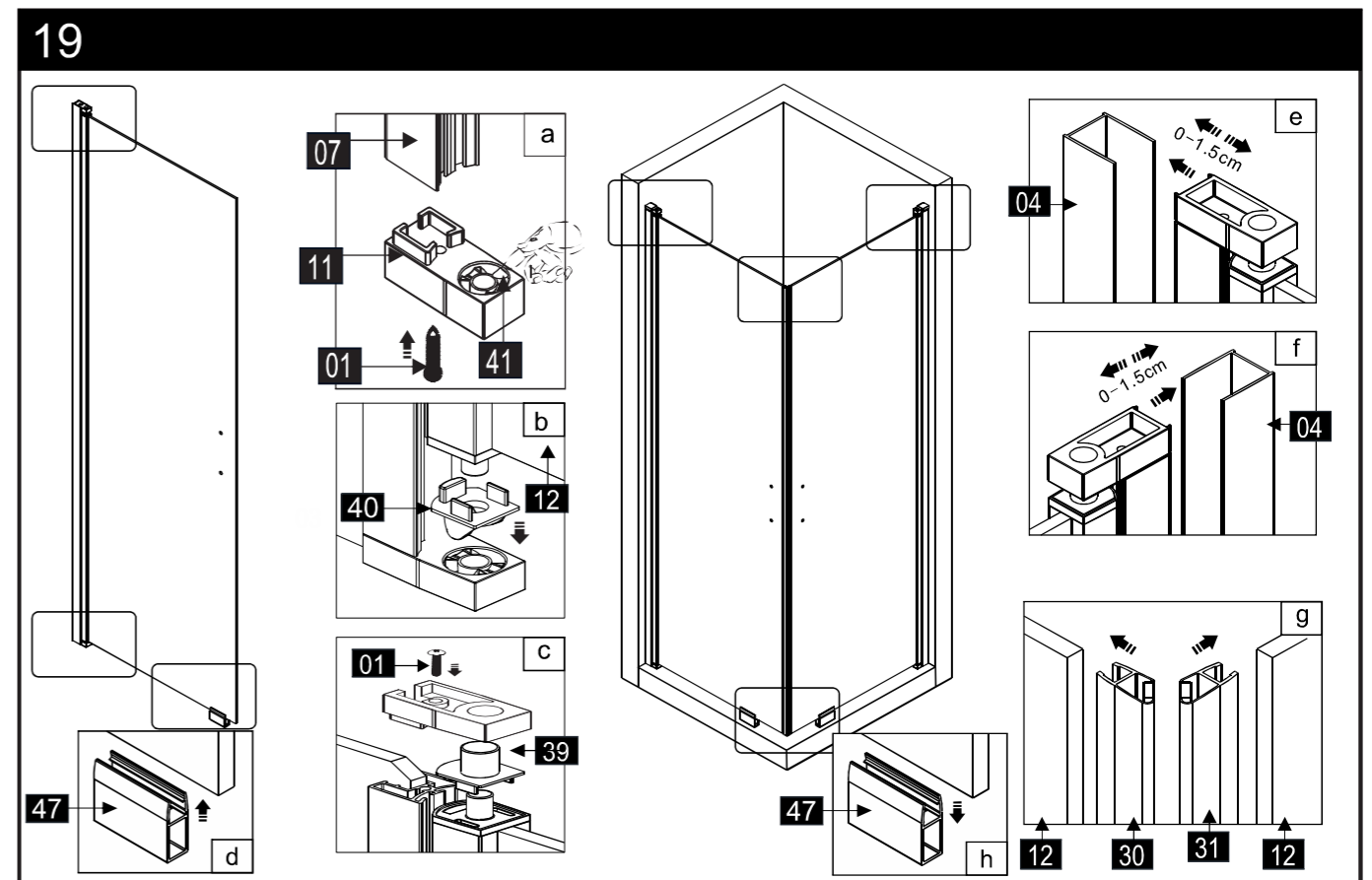
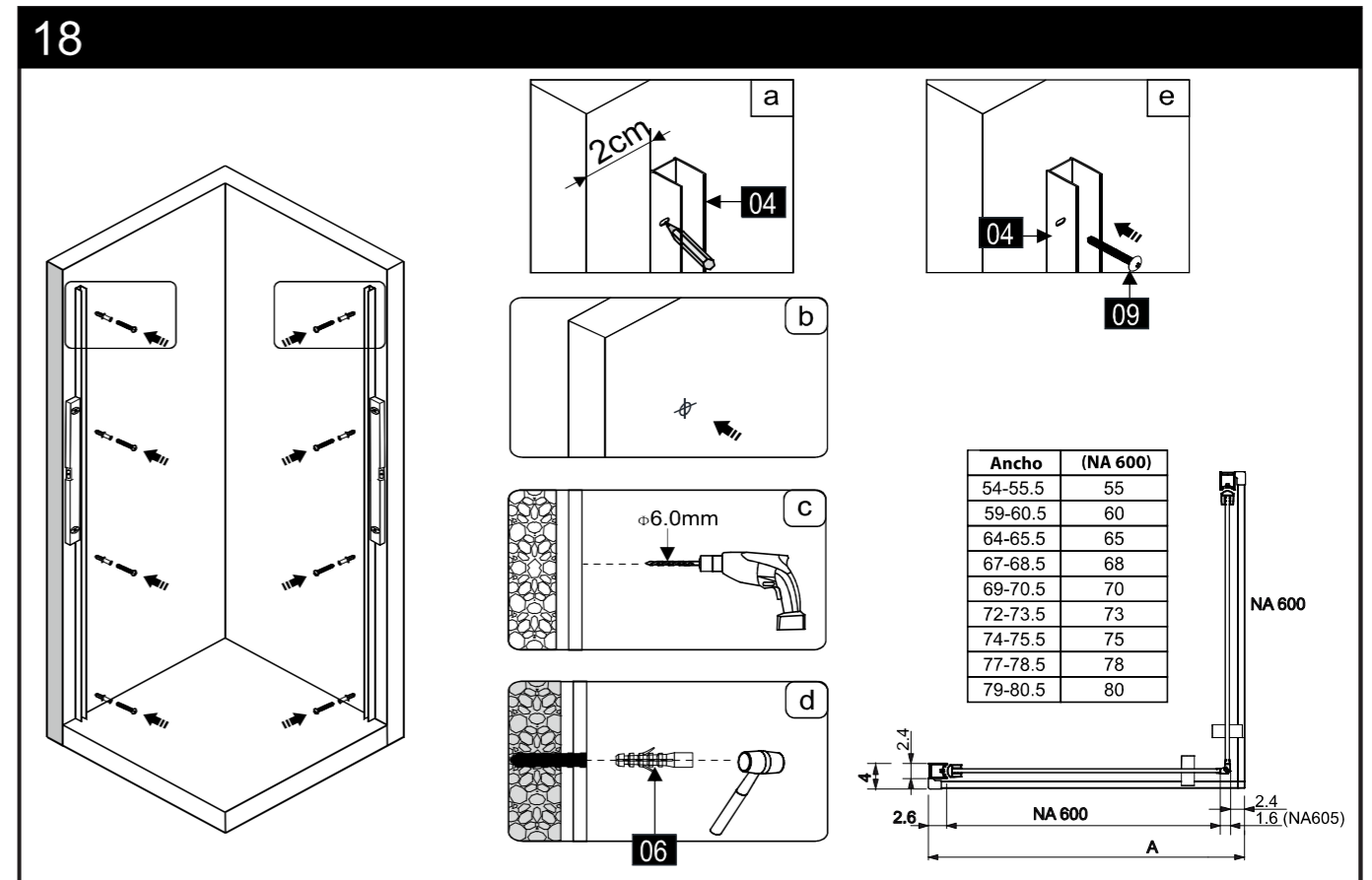
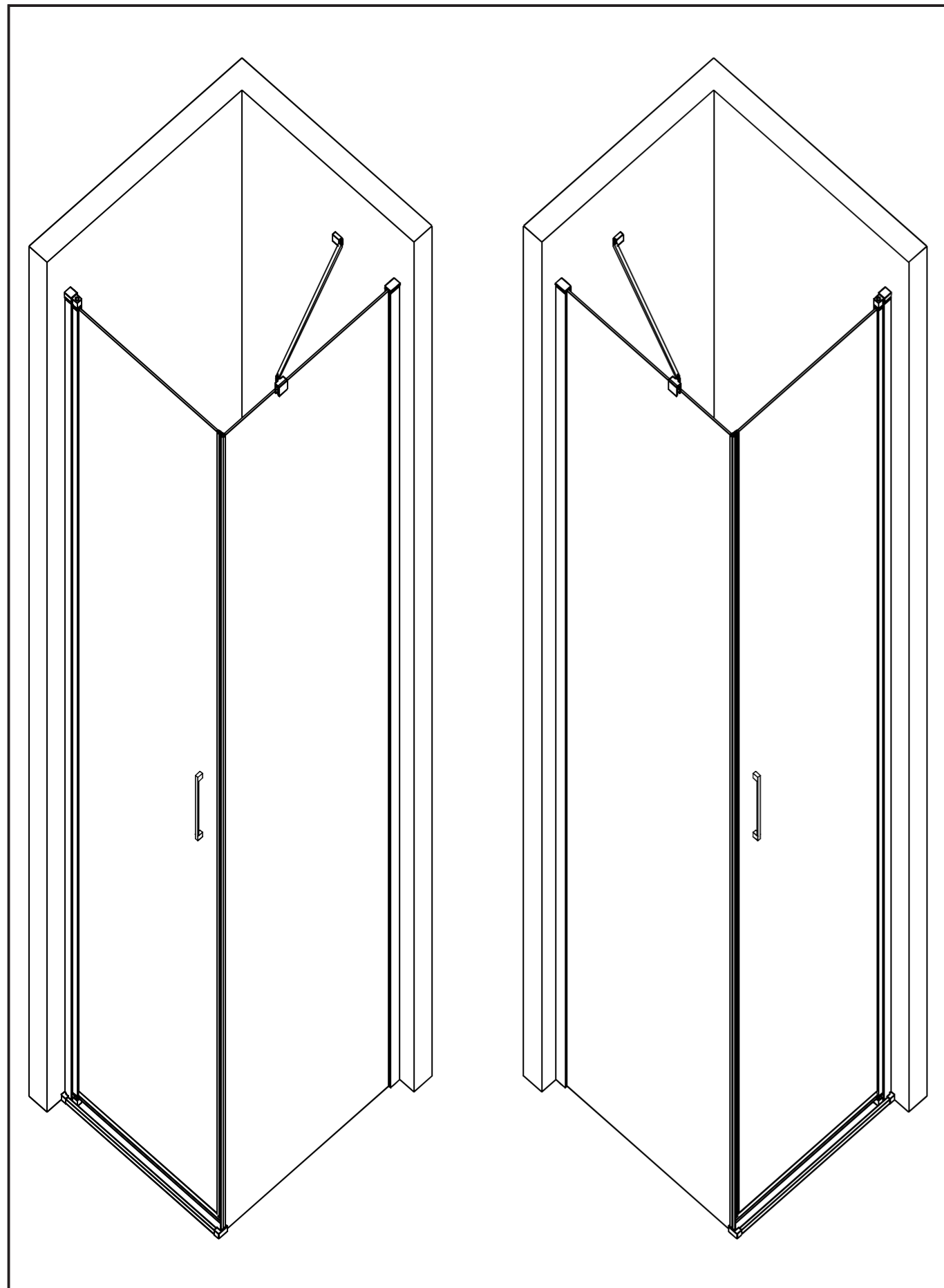

20

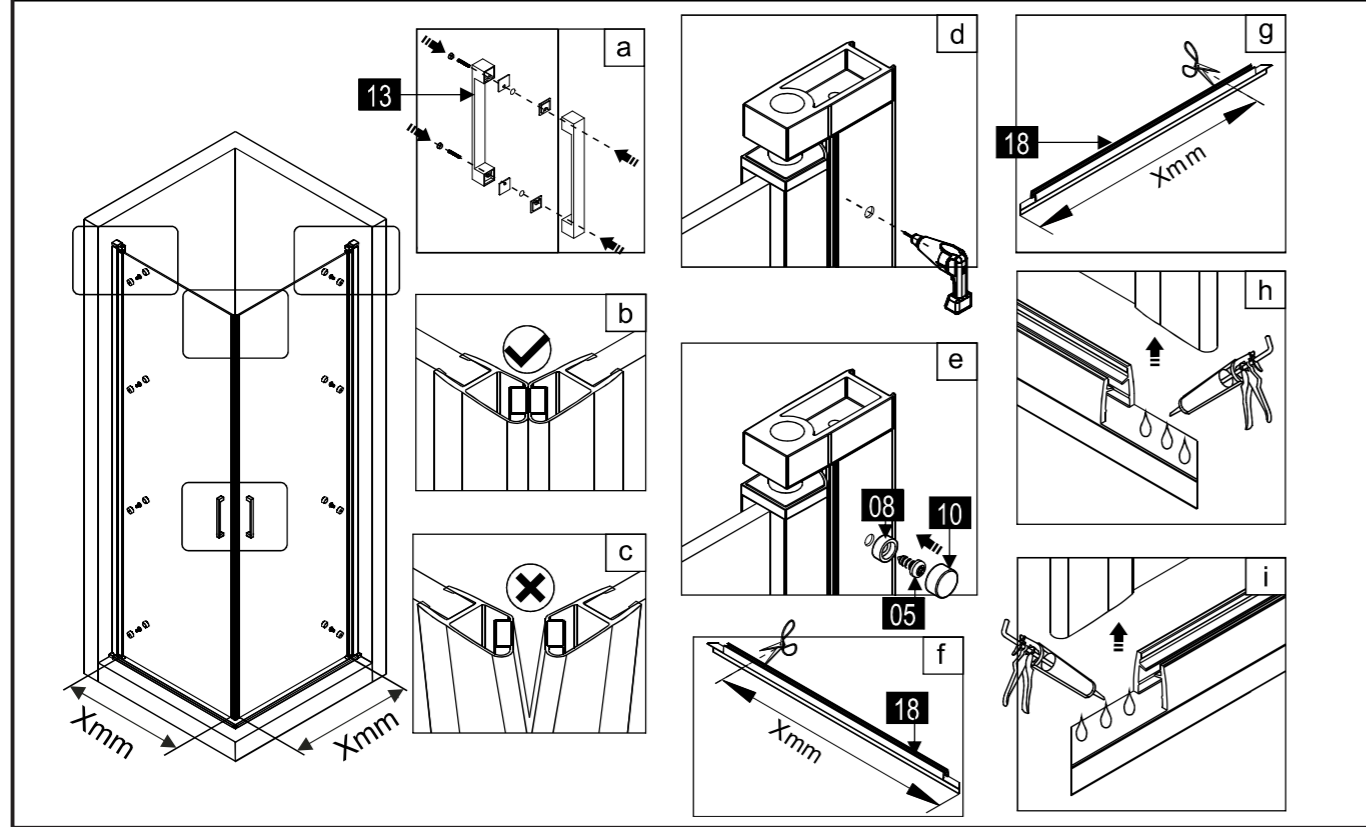

21

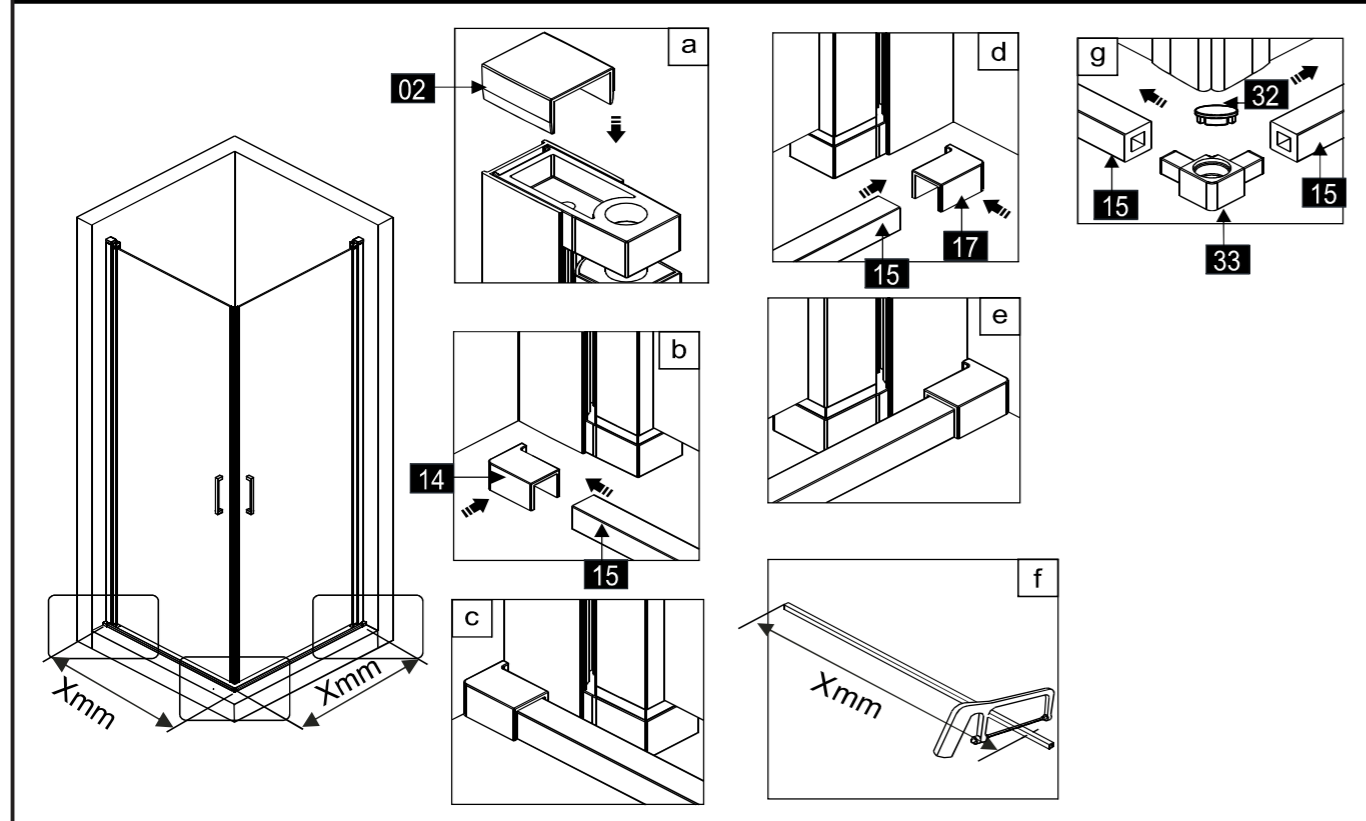

22

