



3" AND 5" DIAL BIMETAL THERMOMETER

MODEL BR3 AND BR5



Model BR3
3" Dial Bi-Metal Thermometer

FEATURES:

- All Stainless Steel Construction
- 3" (75mm) and 5" (127mm) dial size
- Glass Lens
- Anti-Parallax Dial
- Vibration resistant design for reduced needle flutter
- Fast Response
- Hermetically sealed IP68
- Accuracy: $\pm 1\%$ Full Scale
- Welded Stem

APPLICATIONS:

- Heating and Air Conditioning
- Industrial Wastewater
- Accurate Temperature Measurements

SPECIFICATIONS:

- Dial: 3" (75mm) and 5" (127mm)
- Aluminum with black markings, anti-parallax
- Case, Ring and Stem AISI 304 SS
- Recalibrator Screw Standard
- Lens: Glass, hermetically sealed
- Connection: $\frac{1}{2}$ " NPT standard
- Movement: Bi-metallic coil
- Pointer: Aluminum, painted black
- Maximum Operating Pressure: 125 PSI (861 kPa)
- Operating Temperature: 75% of full scale value (recommended maximum)
- Ambient Temperature: -58°F to 248°F (-50°C to 120°C)
- Accuracy: $\pm 1\%$ of full scale
- Enclosure Rating: IP68

ORDERING GUIDE

STEM LENGTH*	PART NUMBER		CODE	RANGE
	3" DIAL	5" DIAL		
2.5"	BR3-2	BR5-2	TA	-40/120 F & C
4"	BR3-4	BR5-4	TB	-40/160 F & C
6"	BR3-6	BR5-6	TE	0/150 F & C
9"	BR3-9	BR5-9	TG	0/200 F & C
12"	BR3-12	BR5-12	TJ	20/240 F & C
15"	BR3-15	BR5-15	TI	0/250 F & C
18"	BR3-18	BR5-18	TM	50/300 F & C
24"	BR3-24	BR5-24	TP	50/400 F & C
			TR	50/550 F & C
			TS	150/750 F & C
			TT	200/1000 F & C

BR5SL-T-001
REV-A

3" AND 5" DIAL BIMETAL THERMOMETER

DIMENSIONAL DRAWING

All dimensions are in inches (mm)

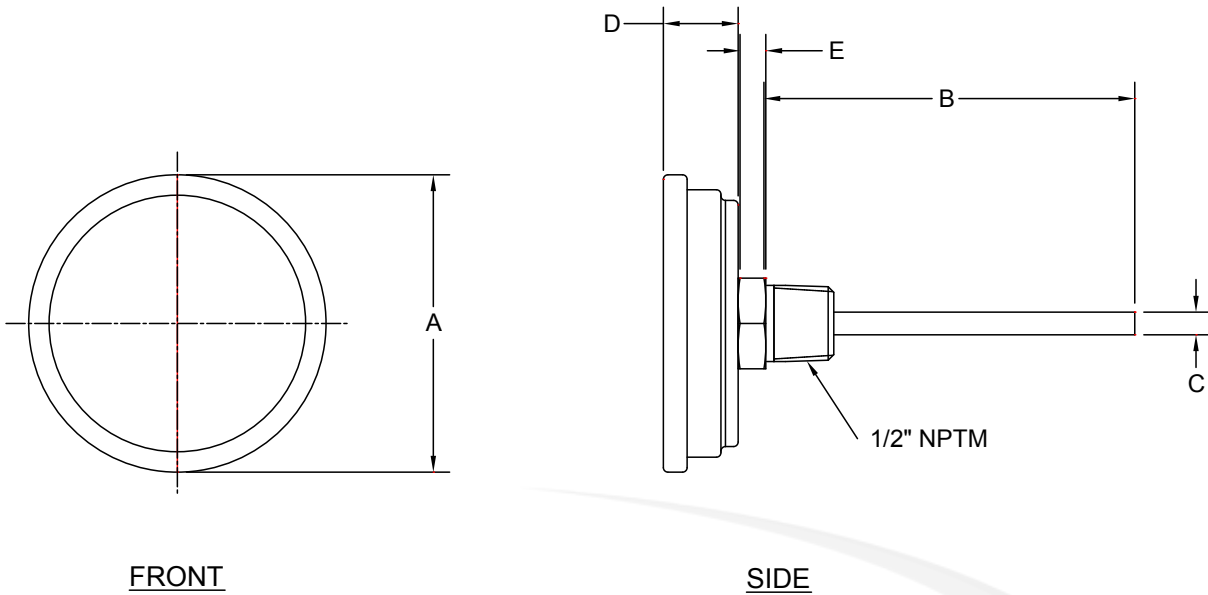

BR3-4-TG-C
3" BIMETAL THERMOMETER
1/2" NPT, 0-100 C
BACK, 4" STEM

		A	B	C	D	E
3" DIAL	IN.	3.18"	STEM LENGTH	.25"	.60"	.38"
	MM	80.78	STEM LENGTH	6.45	15.24	9.76
5" DIAL	IN.	5.13"	STEM LENGTH	.25"	.67"	.38"
	MM	130.87	STEM LENGTH	6.45	16.95	9.76

All specifications are for reference purposes only. In the interests of continuous product improvement, all specifications are subject to change without notice. Please contact Blue Ribbon Corporation for assistance with your application.

