

QH500

AREA FLOOD LIGHT



- ▶ **Material:** Powder Coated Cast Aluminum
- ▶ **Lens:** Clear, Heat Resistant, Tempered Glass
- ▶ **Lamp:** Double Ended 118mm

MODEL NUMBER	LAMP TYPE	ILLUMINANT TYPE	WATTS (W)	VOLTS (V)	LAMP(S) INCLUDED?
QH500	DE/118MM	QUARTZ	500	120	YES

- ▶ **Adjustable Knuckle with 1/2" NPT**
- ▶ **Ground Mounting Spikes:** LV-S6 (sold separately)
- ▶ **Available Color:** White
- ▶ **ETL Approved**

Overall Dimensions:
8.00"H x 9.00"W x 6.00"D

Weight: 2.20 lbs
Approximate Wire Length: 5.5"
Box Dimensions:
7.75"H x 10.25"W x 4.25"D

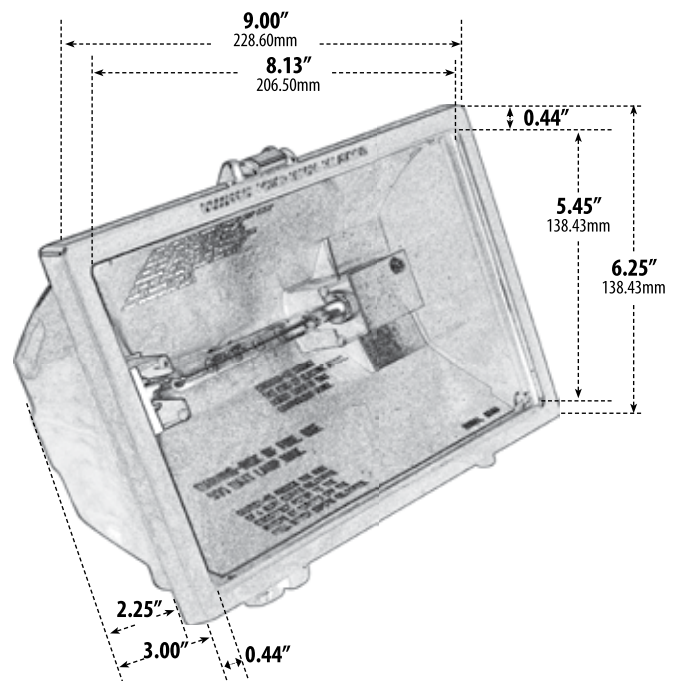

DABMAR
LIGHTING

DABMAR LIGHTING INCORPORATED

2140 Eastman Ave . Oxnard, CA 93030 . 805.604.9090 . f: 805.604.9050 . www.dabmar.com