

# P-ARM-GM2

## ROUND WALL MOUNTED ARM

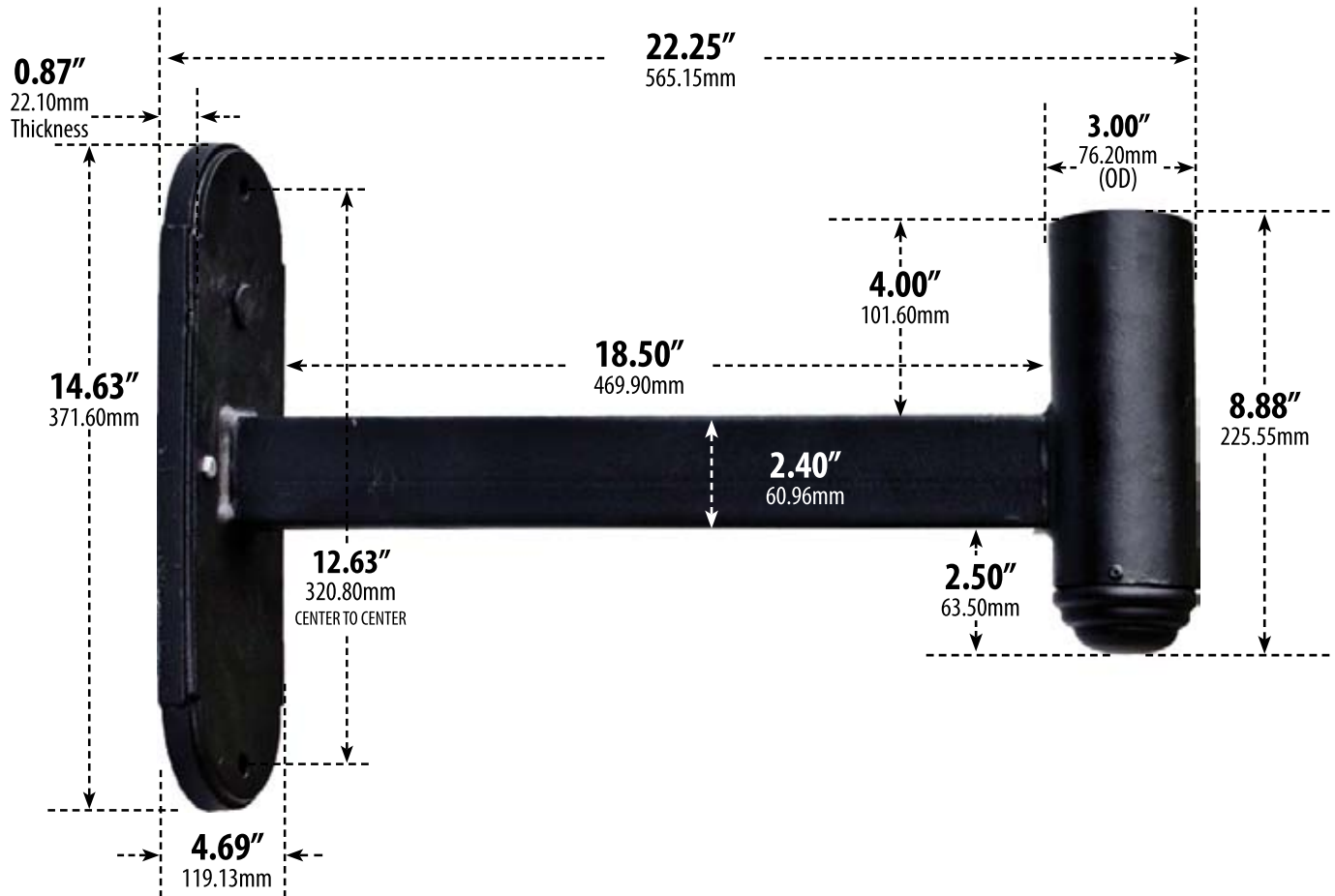

- ▶ **Designed for Post Top Fixtures**
- ▶ **Material:** Powder Coated Galvanized Steel with Welded Base
- ▶ **Available Finish:** Black, Verde Green

Overall Dimensions:  
14.63"H x 4.69"W x 22.25"D

Weight: 11.2 lbs

P-ARM-GM2	LARGE WALL MOUNT ARM FOR POST TOP FIXTURES
-----------	--

**DABMAR**  
LIGHTING

DABMAR LIGHTING INCORPORATED

2140 Eastman Ave . Oxnard, CA 93030 . 805.604.9090 . f: 805.604.9050 . www.dabmar.com