

Type \_\_\_\_\_  
 Project \_\_\_\_\_  
 Catalog No. \_\_\_\_\_  
 Lamp/Wattage \_\_\_\_\_

**NTL-264** (200 Series Low Voltage Track)  
**MR16 V-Tec Gimbal style low voltage track**  
 Lamp: 20W - 50W Halogen MR16

**PRODUCT DESCRIPTION**

Universal open back gimbal ring for cool operation. Vertical design extends life of the transformer. Low profile, simple and clean gimbal appearance.

**FEATURES**

- Clear shield included with the fixture.
- High strength stainless steel electrical contacts.
- One or two circuit track capable.

**CONSTRUCTION**

**Socket**  
 Porcelain socket for GU5.3 12V MR16 lamp.

**Lamp**  
 One 50W 12V MR16 Halogen Lamp (Ordered Separately).

**ELECTRICAL SYSTEM**

**1. Transformer** – Integral 12V 50W electronic transformer included. Solid state electronic transformer provides noise-free voltage reduction and operation. If dimming, use electronic low voltage rated only dimming controls.

**2. Wiring** - Teflon coated wire lead connects socket and housing to electrical contact head. Teflon coating is durable and resists heat degradation from lamp and housing radiation.

**FINISHES**

Black, Silver, and White heat rated baked enamel paint. Custom painting or anodizing for special applications is also available. Custom finishes will require lead times that vary depending on vendor schedule. Please consult factory for quotation, and provide either a Dunn Edwards number or color chip for exact matching.

**OPTIONAL ACCESSORIES**

NM-100/MR16 MR16 Filter (Blue, Clear, Frosted, Green, Linear, Pink, Red, Spread, Yellow)

**LABELS AND LISTINGS**

UL Listed.

**DIMENSIONS**

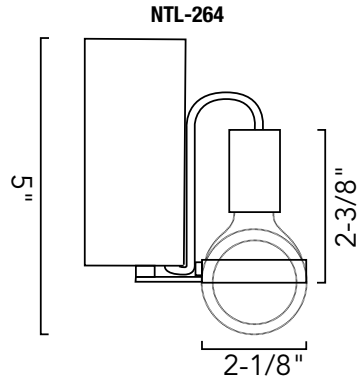

Diameter: 2-1/8"  
 Length: 2-3/8"  
 Max. Extension: 5"



**200 Series Low Voltage Gimbal style Track Heads**

Catalog No.	Finishes
NTL-264	B = Black
	S = Silver
	W = White

Create a complete track head number: 200 Series Example: NTL - 264 B