

Type _____
 Project _____
 Catalog No. _____
 Lamp/Wattage _____

NTH-108 (Line Voltage Track)

Rear Loading Gimbal Ring.

Lamp: 150W PAR38 (not included)

PRODUCT DESCRIPTION

Line voltage cylindrical housing with round back design and black baffle. includes a yoke that provides full adjustment of light source for special aiming and has single tightening knobs assure secure lock on angle position.

FEATURES

- Die cast aluminum provies superior strength and rigidity.
- Black baffle eliminates glare and adds finished touch.
- One or two circuit track capable.

CONSTRUCTION

Housing

0.030" Deep drawn steel construction with simple, yet decorative design. All edges are softened for aesthetic appearance

Baffle

0.085" Black finished phenolic high heat rated plastic baffle, provides finished appearance and assists in eliminating glare from housing interior

Yoke

0.085" Rigid steel "wishbone" yoke connects fixture housing to electrical contact head. Single plastic angle tightening knobs maintain clean, decorative appearance of the fixture and provides secure angle position

ELECTRICAL SYSTEM

Socket

Porcelain jacketed aluminum screw thread medium-base socket

Lamp

150W PAR38 Maximum (not included)

One/Two Circuit Conversion

Positive contact (opposite neutral and ground contacts) is preset to "down" position at factory but may be raised to the higher position to install onto the second circuit of Nora Lighting NT- 2300 series two-circuit track.

FINISHES

Black, and White powder coated finishes availabe, Natural Metal, Silver and Bronze also available. Contact warehouse for custom finishes.

LABELS AND LISTINGS

UL Listed.

DIMENSIONS

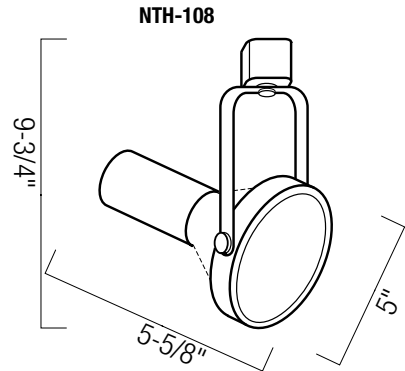

Diameter: 5"
 Length : 5-5/8"
 Max. Extension: 9-3/4"



Rear Loading Gimbal Ring.

Catalog No.	Min. - Max Wattage	Finishes	Style
NTH-108	150W	B = Black	Blank = H-Style
		W = White	J = J-Style
		N = Natural Metal	L = L-Style
		S = Silver	
		BZ = Bronze	

Create a complete track head number: Example: NTH - 1 08B