

Type _____

Project _____

Catalog No. _____

Lamp/Wattage _____

NRS18-122**Ulysses PAR Front Loading Incandescent Luminaire**

Lamp: (1) 50W PAR 20 (not included)

PRODUCT DESCRIPTION

Line voltage Incandescent luminaire. Heavy die-cast construction provides superior strength, rigidity, and heat dissipation. Locking front ring protects lamp and enhances appearance. Front loading capability provides quick, easy lamp maintenance with minimal interference with original fixture aiming. Luminaire has small stem extending from rail connector, allowing full aiming and 350 degree adjustment with a low profile.

SPECIFICATION**HOUSING**

1mm die-cast aluminum, overall outer diameter is 50mm, 74mm in length. Upper perimeter provided with vents at rear for best heat dissipation. Provided with three threaded protruding knobs, one for ground lead connection and two for securing the lampholder in place. Provided with integral projection for fixing firmly to the aiming handle.

STEM

Die-cast aluminum 3.9 mm thick, half U shaped, 100mm long by 15mm wide secured to lampholder on one end and to the luminaire adaptor at the other.

ARM

Material: die-cast aluminum 0.07".

ELECTRICAL**WIRING**

Size: 18 Gauge AWG, 90°C, 600V

LAMP HOLDER

Medium Base, Porcelain, rated for maximum 600V, 660W.

LAMP CLIP

0.5mm Aluminum, 103 mm outer diameter, 35 mm wide. Secured to lamphoder by a 4.9mm thick and 101mm long metal bar.

UNIVERSAL CONNECTOR

Construction: 0.07" die cast aluminum shell

Contacts: Copper for positive and neutral Copper contact spring on top to provide solid contact with ground conductor located on top of rail.

FINISHES

Brushed Nickel, Bronze, and Silver are available.

LABELS AND LISTINGS

UL and cUL Listed for dry location only.

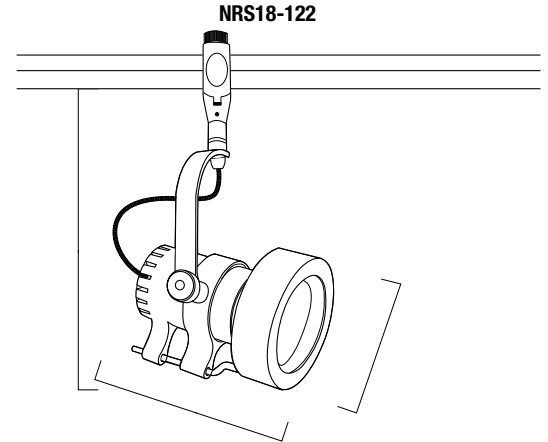
DIMENSIONS

Height : 3-9/16"
Width : 2-1/4"
Max. Extension : 8-3/4"

**Ulysses Die-Cast PAR Front Loading Incandescent Luminaire**

Catalog No. _____

Finish _____

NRS18-122**BN = Brushed Nickle****BZ = Bronze****S = Silver**Create a complete item number: Example: **NRS18-122BN**