

Type
Project
Catalog No.
Lamp/Wattage

**NRS11-251**

**Kano Spot Lamp Holder with Detachable Ring**

Lamp: (1) 50W MR16 GU10 120V (included)

**PRODUCT DESCRIPTION**

Conical MR16 lamp holder with 1" frosted glass border at front of fixture. Glass could be removed for replacement or for alternate color scheme (Color schemes for glass are BU-Frosted Blue and FR-Frosted Clear). Luminaire has small stem extending from rail connector, allowing full aiming and 350° adjustment with a low profile.

**SPECIFICATION**

**HOUSING**

Main body constructed from one-piece .08" die-cast aluminum. Rear of housing tapered to minimize fixture profile. Housing accepts frosted glass screw ring. It uses stainless steel screws to secure frosted glass accent and locking ring. Curved stem at bottom of housing provides unique design element and cool surface to allow user to adjust fixture position while fixture is in operation.

**STEM**

Material: 0.07" die-cast aluminum.

**ELECTRICAL**

**WIRING**

Size: 18 Gauge AWG 200°C, 300V

**SOCKET**

GU10 porcelain base with nickel plated copper contacts.

**UNIVERSAL CONNECTOR**

Construction: 0.07" die cast aluminum shell  
 Contacts: Copper for positive and neutral Copper contact spring on top to provide solid contact with ground conductor located on top of rail.

**FINISHES**

Brushed Nickel, Bronze, and Silver are available.

**LABELS AND LISTINGS**

UL and cUL Listed for dry location only.

**DIMENSIONS**

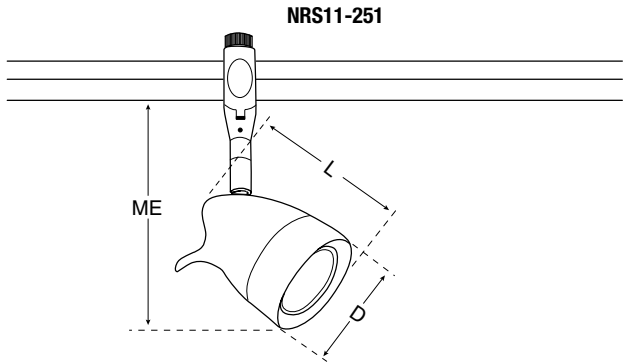

Diameter : 3-5/8"  
 Length : 2-5/8"  
 Max. Extension : 6-1/8"



**Kano Spot Die-Cast Lamp Holder with Detachable Frosted Glass Ring**

Catalog No.	Finish
<b>NRS11-251</b>	BN = Brushed Nickle BZ = Bronze S = Silver

Create a complete item number: Example: **NRS11-251BN**