

# LV307-MR

## ADJUSTABLE DRIVE OVER IN-GROUND WELL LIGHT

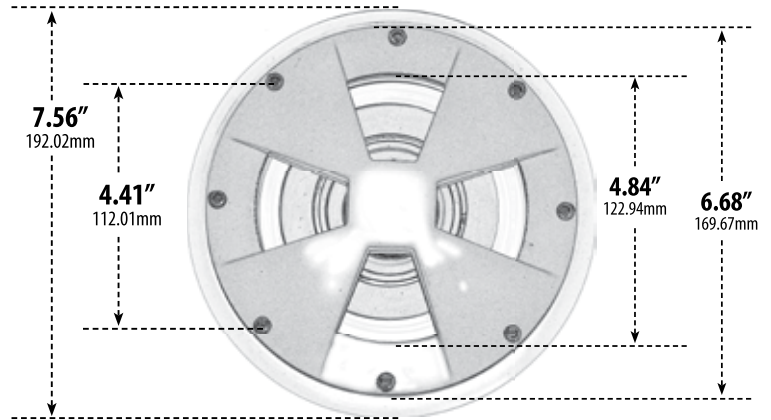

- ▶ **Material:** Powder Coated Cast Aluminum with PVC Sleeve
- ▶ **Lens:** Clear, Heat Resistant, Tempered Glass
- ▶ **Lamp:** MR16 (50W Maximum)

MODEL NUMBER	LAMP TYPE	ILLUMINANT TYPE	WATTS (W)	VOLTS (V)	LAMP(S) INCLUDED?
LV307-MR	MR16	HALOGEN	20	12	YES
LV-LED307-MR	MR16-LED	3 LEDs	3	12	YES

Pre-wired with UL Listed Direct Burial Wire/Cable

- ▶ **Available Finish:** Black, Bronze, Gray, Verde Green
- ▶ **ETL Approved**

Overall Dimensions:  
7.50"H x 7.56"W x 7.56"D

Weight: 3.0 lbs  
Approximate Wire Length: 16"

Box Dimensions:  
7.00"H x 7.75"W x 7.75"D

**DABMAR**  
LIGHTING

DABMAR LIGHTING INCORPORATED

2140 Eastman Ave . Oxnard, CA 93030 . 805.604.9090 . f: 805.604.9050 . www.dabmar.com