

# GM9100

## POST FIXTURE - TRIPLE ARMS

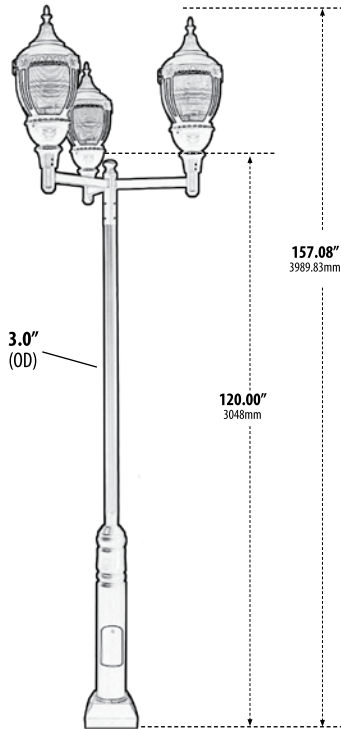
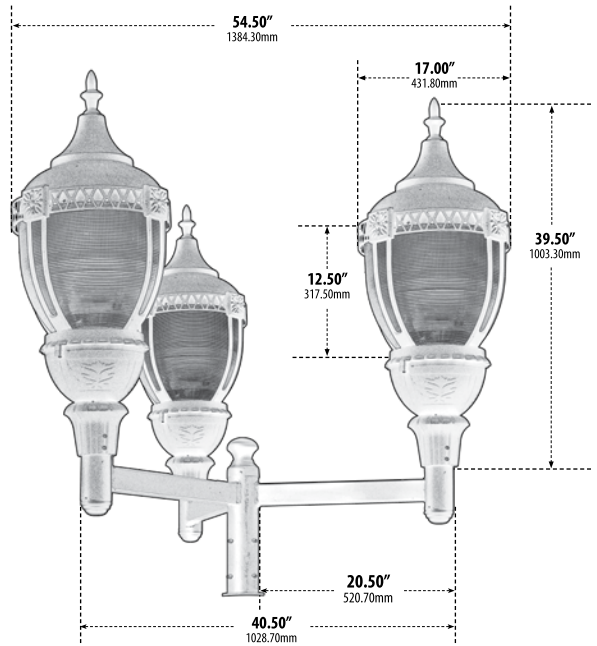
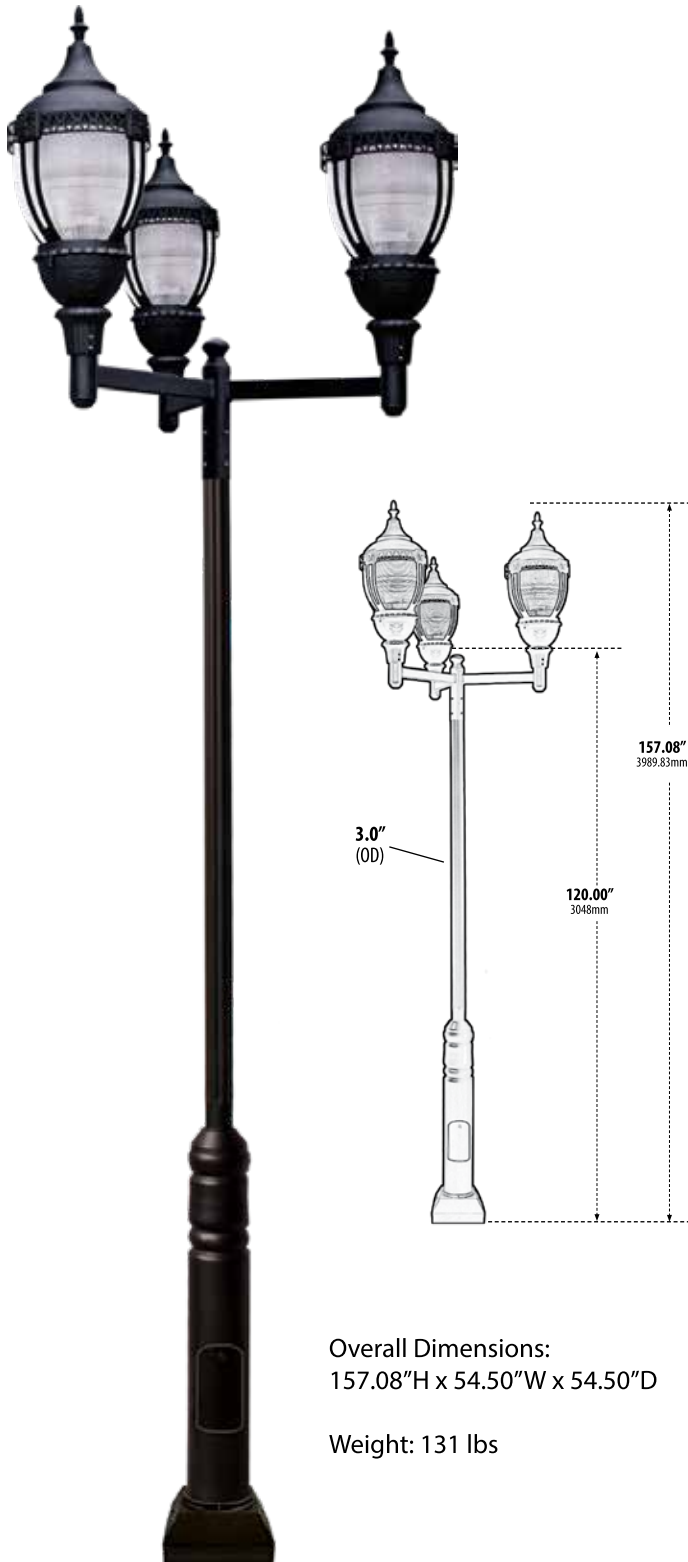

Overall Dimensions:  
157.08"H x 54.50"W x 54.50"D

Weight: 131 lbs

- ▶ **Material:** Powder Coated Cast Aluminum
- ▶ **Lens:** Clear, Prismatic, Heat Resistant, Polycarbonate
- ▶ **Available Finish:** Black, Verde Green
- ▶ **ETL Approved**

MODEL NUMBER	LAMP TYPE	ILLUMINANT TYPE	WATTS (W)	VOLTS (V)	LAMP(S) INCLUDED?
GM9100	A-Type	Incandescent/MOG	3 x 100	120	NO
GM9101	HID	HPS/MOG	3 x 70	120	YES
GM9101-MT	HID	HPS/MOG	3 x 70	MT	YES
GM9102	HID	HPS/MOG	3 x 100	120	YES
GM9102-MT	HID	HPS/MOG	3 x 100	MT	YES
GM9103	HID	HPS/MOG	3 x 150	120	YES
GM9103-MT	HID	HPS/MOG	3 x 150	MT	YES
GM9104	HID	MH/MOG	3 x 70	120	YES
GM9104-MT	HID	MH/MOG	3 x 70	MT	YES
GM9105	HID	MH/MOG	3 x 100	120	YES
GM9105-MT	HID	MH/MOG	3 x 100	MT	YES
GM9106	HID	MH/MOG	3 x 150	120	YES
GM9106-MT	HID	MH/MOG	3 x 150	MT	YES
GM9107	HID	MH/MOG	3 x 175	120	YES
GM9107-MT	HID	MH/MOG	3 x 175	MT	YES
GM9100-LED75	LED	LED-MOG	3 x 75	120-277	YES
GM9100-LED100**	INTEGRATED LED	LED	3 x 100	120-277	YES
GM9100-LED120	LED	LED-MOG	3 x 120	120-277	YES

**\*\*GM9100-LED100 - Integrated LED Board - DLC and ETL Approved (Black Finish Only)**

**DABMAR**  
LIGHTING

DABMAR LIGHTING INCORPORATED

2140 Eastman Ave . Oxnard, CA 93030 . 805.604.9090 . f: 805.604.9050 . www.dabmar.com