

GM601

POST TOP FIXTURE

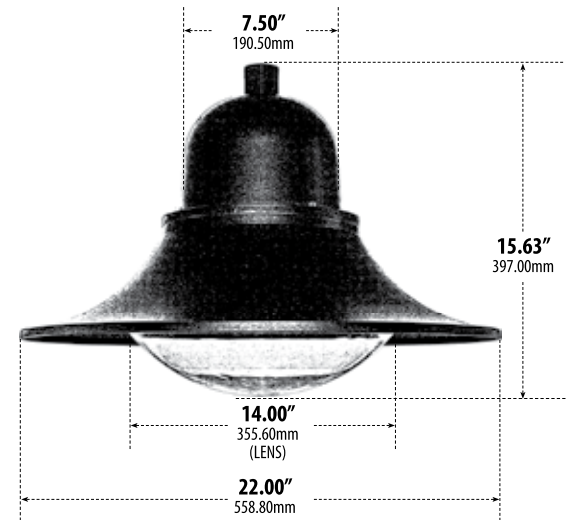
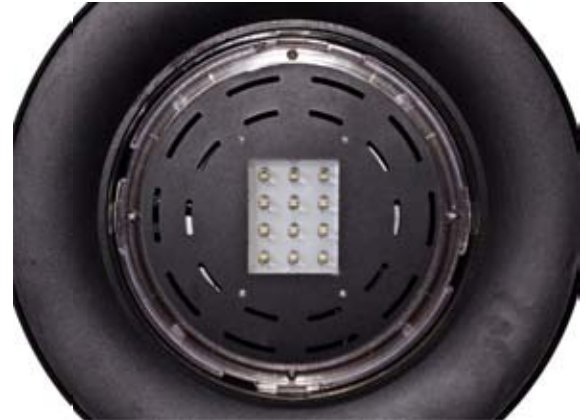

- ▶ **Material:** Powder Coated Cast Aluminum
- ▶ **Lens:** Clear, Heat Resistant, Polycarbonate Convex Lens
- ▶ **Available Finish:** Black, Verde Green
- ▶ **Color Temperature:** 6500K
- ▶ **Lumens:** 5010
- ▶ **Life Expectancy:** 30,000 Hrs
- ▶ **ETL Approval Pending**

MODEL NUMBER	LAMP TYPE	ILLUMINANT TYPE	WATTS (W)	VOLTS (V)	LAMP(S) INCLUDED?
GM601	LED	LED BOARD	60	120-277	YES

Overall Dimensions:
35.50"H x 30.07"W x 22.00"D

Weight (Head Only): 15.4 lbs.

Weight (Arm Only): 12 lbs.

Box Dimensions:

17.75"H x 18.00"W x 18.00"D (Head Only)

DABMAR
LIGHTING

DABMAR LIGHTING INCORPORATED

2140 Eastman Ave . Oxnard, CA 93030 . 805.604.9090 . f: 805.604.9050 . www.dabmar.com