

# DSL-LED1200

## RECESSED BRICK, STEP AND WALL LIGHT

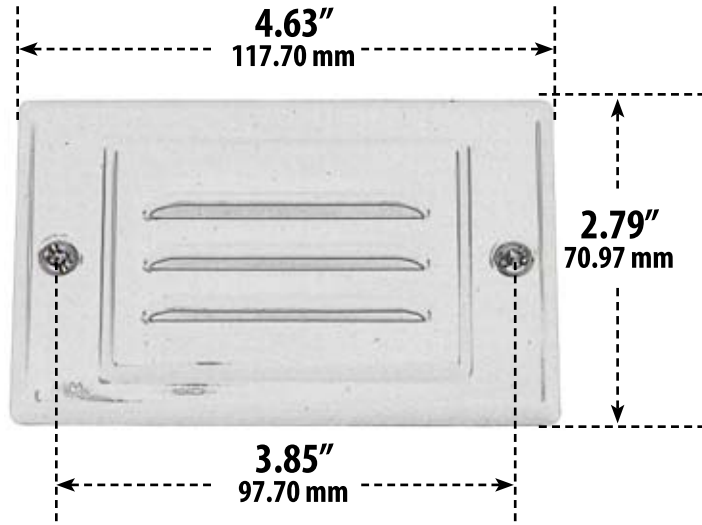

- ▶ **Material:** Powder Coated Cast Aluminum (Faceplate)
- ▶ **Lens:** Heat Resistant, Plastic Lens

MODEL NUMBER	LAMP TYPE	ILLUMINANT TYPE	WATTS (W)	VOLTS (V)	LAMP(S) INCLUDED?
DSL-LED1200	LED COB	LED	1.5	120	YES

- ▶ **Color Temperature:** 3000K
- ▶ **Available Finish:** Black, Bronze, White
- ▶ **Life Expectancy:** 50,000 Hrs
- ▶ **Lumens:** 150 Lumens
- ▶ **Recessed Mount**
- ▶ **2 Covers Included:** (1 Louvered Down, 1 Open Face)
- ▶ **ETL Approval Pending**

Overall Dimensions:  
2.02"H x 4.63"W x 2.79"D

Weight: 0.40 lbs  
Box Dimensions: 4.75"H x 3.00"W x 2.38"D  
Lamp Included

**DABMAR**  
LIGHTING

DABMAR LIGHTING INCORPORATED

2140 Eastman Ave . Oxnard, CA 93030 . 805.604.9090 . f: 805.604.9050 . www.dabmar.com