

# Delta™

Children's Products

## 3 DRAWER CHEST

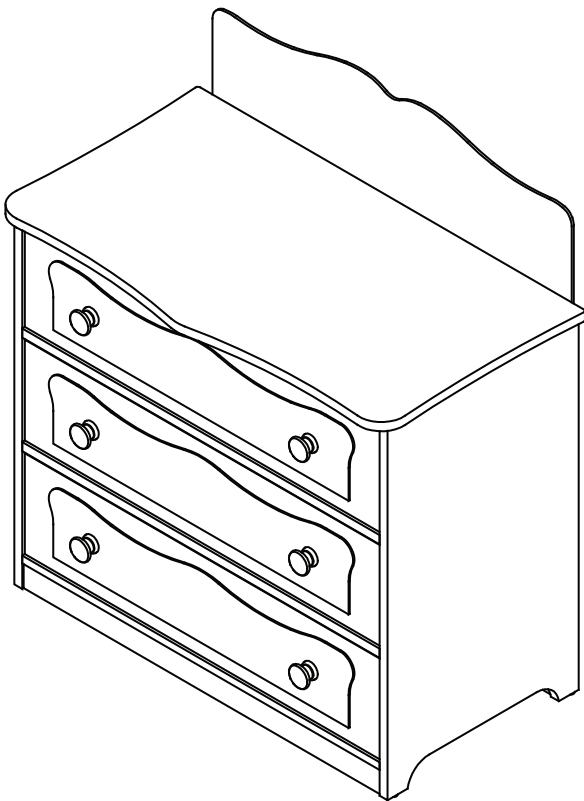

READ ALL INSTRUCTIONS BEFORE ASSEMBLY AND USE.

**KEEP INSTRUCTIONS FOR FUTURE USE.**

**⚠️ ADULT ASSEMBLY REQUIRED**

DUE TO THE PRESENCE OF SMALL PARTS DURING ASSEMBLY, KEEP OUT OF REACH OF CHILDREN UNTIL ASSEMBLY IS COMPLETE.

LISEZ TOUTES LES INSTRUCTIONS AVANT L'ASSEMBLAGE ET L'UTILISATION. CONSERVEZ LES INSTRUCTIONS POUR UN USAGE ULTERIEUR.

**⚠️ L'ASSEMBLAGE DOIT ETRE FAIT PAR UN ADULTE**

A CAUSE DE LA PRESENCE DE PETITES PIECES, PENDANT L'ASSEMBLAGE GARDEZ HORS DE PORTEE DES ENFANTS JUSQU'A CE QUE CELUI-CI SOIT TERMINE.

LEA TODAS LAS INSTRUCCIONES ANTES DE ENSAMBLAR Y USAR.

**MANTENGA LAS INSTRUCCIONES PARA SU USO FUTURO.**

**⚠️ DEBE SER ENSAMBLADO POR UN ADULTO**

DEBIDO A LA PRESENCIA DE PIEZAS PEQUEÑAS DURANTE EL ENSAMBLAJE, MANTENGA FUERA DEL ALCANCE DE LOS NIÑOS HASTA QUE COMPLETE EL ENSAMBLAJE.

THIS PRODUCT IS NOT INTENDED FOR INSTITUTIONAL OR COMMERCIAL USE.

**STYLE No: FL86864PS**



COLOR



REV



FACTORY

When contacting Delta Consumer Care you will need to reference the above number.

Consumer Care:

[www.DeltaChildren.com](http://www.DeltaChildren.com)

Delta Children's Products  
114 West 26th Street  
New York, NY 10001  
Tele.212-645-9033

To register your product for important safety alerts and updates to your product please visit [www.DeltaChildren.com](http://www.DeltaChildren.com) and click on Product Registration.

## **WARNING**

**Serious or fatal crushing injuries can occur from furniture tip-over. To help prevent tip-over:**

- Place heaviest items in the lowest drawers.
- Unless specifically designed to accommodate, **do not** set TV's or other heavy objects on the top of this product.
- Never** allow children to climb or hang on drawers, doors, or shelves.
- Never** open more than one drawer at a time.
- Use of tip-over restraints may only reduce, but not eliminate, the risk of tip-over.**
- Always monitor your child's activity when in the nursery.
- Do not** allow standing in drawers.
- Do not** allow standing on top of this product.
- Accessory Items must be securely fastened to this product according to the instructions provided with those items.
- To avoid head injury, do not allow children to play underneath open drawers.
- Do not leave drawers open when not in use.

## **AVERTISSEMENT**

Le renversement du meuble peut entraîner des blessures graves ou mortelles. Pour aider à prévenir tout renversement :

- Placez les objets les plus lourds dans les tiroirs du bas.
- Ne déposez pas de postes de télévision ou d'autres objets lourds sur ce meuble, à moins qu'il ne soit conçu spécifiquement à cet effet.
- Ne laissez jamais les enfants monter sur ou se suspendre aux tiroirs, portes et ou tablettes.
- N'ouvrez jamais plus d'un tiroir en même temps.
- L'utilisation de dispositif anti-renversement peut uniquement réduire les risques de renversement, mais ne les élimine pas totalement.
- Surveillez toujours les activités de votre enfant lorsqu'il se trouve dans la chambre d'enfants.
- Ne lui permettez pas de se tenir debout dans les tiroirs.
- Ne lui permettez pas de se tenir debout sur ce meuble.
- Les accessoires doivent être solidement fixés sur ce produit conformément aux instructions fournies avec lesdits éléments.
- Afin de prévenir toute blessure à la tête, ne laissez pas les enfants jouer sous les tiroirs ouverts.
- Ne laissez pas les tiroirs ouverts lorsque vous ne les utilisez pas.

## **ADVERTENCIA**

Pueden producirse lesiones graves o mortales por aplastamiento al volcarse muebles. Para evitar vuelcos:

- Coloque los artículos de mayor peso en los cajones inferiores.
- No coloque televisiones ni ningún otro objeto pesado en la parte superior de este producto, a no ser que esté específicamente diseñado para acomodarlo.
- Nunca permita que los niños trepen sobre cajones, puertas o baldas de estantería ni que se cuelguen de ellos.
- Nunca abra más de un cajón al mismo tiempo.
- El uso de herramientas de contención de vuelcos tan solo puede reducir, pero no eliminar, el riesgo de vuelco.
- Vigile siempre la actividad de su hijo cuando se encuentre en su cuarto.
- No permita que nadie se ponga de pie en los cajones.
- No permita que nadie se ponga de pie encima de este producto.
- Los artículos accesorios deben ser fijados a este producto de forma segura según las instrucciones que acompañan a dichos artículos.
- Para evitar lesiones en la cabeza, no permita que los niños jueguen debajo de cajones abiertos.
- No deje cajones abiertos si no los está utilizando.

**NOTES ON ASSEMBLY:**

- During the assembly process whenever using screws or bolts, check each by placing the screw/bolt on the diagram of the item which is drawn actual size and design. Be sure to use the proper size and shape specified in the instructions.
- To assemble this unit you may be required to place the unit on it's side and face. It is strongly recommended that assembly is done on a soft, non-abrasive surface to avoid damaging the finish.

**NOTES ON CARE AND MAINTENANCE:**

- **Do not** scratch or chip the finish.
- Inspect the product periodically, contact delta children's products for replacement parts or questions.
- **Do not** store the product or any parts in extreme temperatures and conditions such as a hot attic or a damp, cold basement. These extremes can cause a loss of structural integrity.
- To preserve the luster of the high quality finish on your product, it is recommended to place a doily or felt pad under any items you place on the finish.
- Clean with a damp cloth, then a dry cloth to preserve the original luster and beauty of this fine finish.
- Do not** use abrasive chemicals.
- Do not** spray cleaners directly onto furniture.
- Lift slightly when moving on carpeting to prevent leg breakage.
- Use of a vaporizer near furniture will cause wood to swell and finish to peel.

**REMARQUES SUR L'ASSEMBLAGE :**

- Lors de l'assemblage, quand vous utilisez vis ou boulons, vérifiez chaque pièce en plaçant le vis/boulon sur le diagramme de la pièce concernée qui est dessiné en taille et forme réelle. Assurez vous d'utiliser la taille et la forme exacte comme il est spécifié dans les instructions.
- Pour assembler cet élément vous pourriez avoir besoin de le placer sur le cote latéral et sur le cote frontal. Il est fortement recommandé de faire l'assemblage sur une surface lisse, non abrasive pour éviter d'endommager les finitions.

**REMARQUES SUR LE SOIN ET L'ENTRETIEN :**

- Ne pas rayer ou ébrécher la finition.
- Examinez de près le produit régulièrement, contactez delta children's products pour les pièces de rechange ou pour poser des questions.
- Ne pas ranger le produit ou des pièces a des températures extrêmes ou dans des conditions comme un grenier chaud ou une cave froide et humide. Ces extrêmes peuvent causer une perte de l'intégrité de la structure du produit
- Pour préserver le lustre original et la beauté de ce fini raffiné nettoyer avec un chiffon humide, puis un chiffon sec.
- Ne pas utiliser des produits chimiques abrasifs
- Ne pas pulvériser un nettoyant directement sur le meuble, pulvériser sur le torchon et puis appliquer sur le meuble. Testez le produit nettoyant sur un endroit discret avant de l'utiliser sur la totalité du meuble
- Lors d'un déplacement sur une moquette ou tapis, soulevez légèrement le meuble pour éviter de casser les pieds.
- L'utilisation d'un vaporisateur près du meuble causera le gonflement du bois et l'écaillage de la finition.

**INFORMACIÓN SOBRE EL MONTAJE:**

- Durante el proceso de montaje, ya utilice pernos o tornillos, compruebe cada uno de ellos colocando el perno/tornillo en el diagrama del artículo donde está dibujado el tamaño y el diseño real. Asegúrese de que utiliza el tamaño y la forma adecuada que especifican las instrucciones.
- Para montar esta unidad, puede que se le solicite que coloque la unidad de lado y de cara. Se recomienda encarecidamente que realice el montaje sobre una superficie no abrasiva para evitar dañar el acabado.

**INFORMACIÓN SOBRE CUIDADOS Y MANTENIMIENTO:**

- No arañe ni desconche el acabado.
- Inspeccione el producto con regularidad, póngase en contacto con Delta Children's Products para el recambio de partes o para formular preguntas.
- No guarde el producto ni ninguna de sus partes a temperaturas ni en condiciones extremas como un ático caluroso o un sótano húmedo y frío. Estos extremos pueden provocar una pérdida de integridad estructural.
- Para preservar el brillo del acabado de alta calidad que recubre su producto, se recomienda que coloque un paño o una almohadilla de fieltro debajo de cualquier objeto que coloque sobre el acabado.
- Límpielo con un trapo húmedo y luego con uno seco para preservar el brillo y la belleza originales de este fino acabado.
- No utilice productos químicos abrasivos.
- No pulverice limpiadores directamente sobre el mueble.
- Elévelo ligeramente cuando lo mueva sobre alfombras o moqueta para evitar que se rompan las patas.
- El uso de vaporizadores cerca de muebles puede provocar que la madera se hinche y acabe desconchándose.

**PARTS:** MAKE SURE THAT ALL PRE-ASSEMBLED PARTS ARE TIGHT.

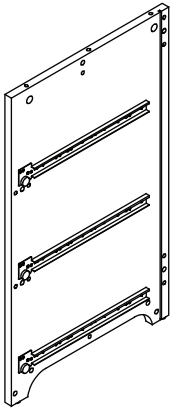

A. Left Side x1  
Part #21968

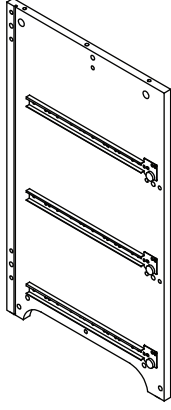

B. Right Side x1  
Part #21969

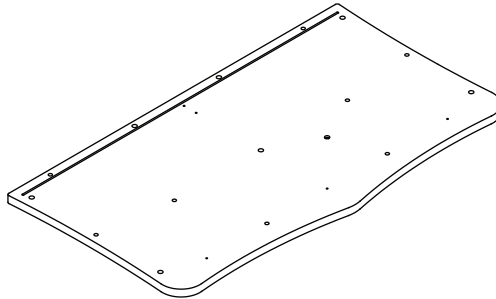

C. Top x1  
Part #21970

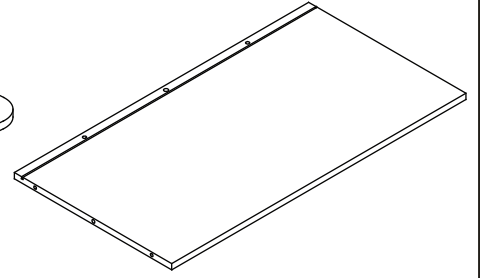

D. Bottom  
Part #21971

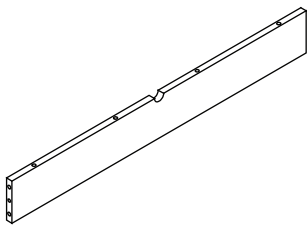

E. Top Back Rail x1  
Part #21972

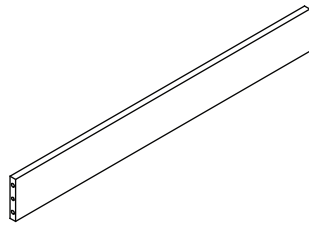

F. Middle Back Rail x1  
Part #21973

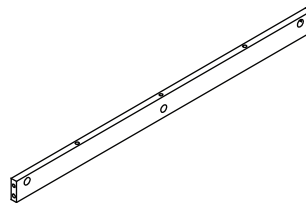

G. Top Center Rail x1  
Part #21974

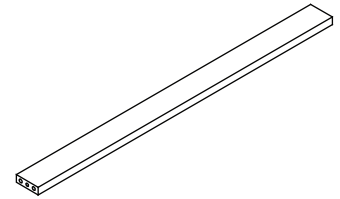

H. Drawer Rail x2  
Part #21975

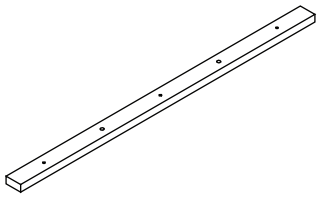

J. Top Front Rail x1  
Part #21976

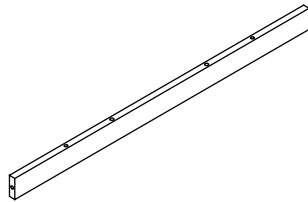

K. Bottom Rail x2  
Part #21977

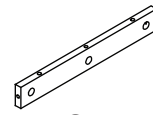

L. Center Support x1  
Part #21978

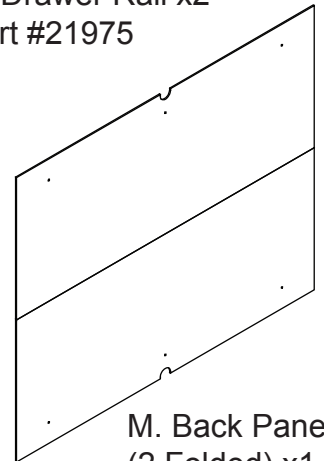

M. Back Panel  
(2 Folded) x1  
Part #21979

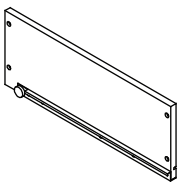

N. Drawer Left  
Side x3  
Part #21980

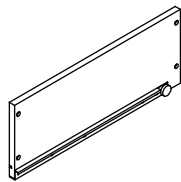

P. Drawer Right  
Side x3  
Part #21981

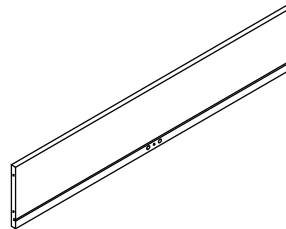

R. Drawer Back x3  
Part #21982

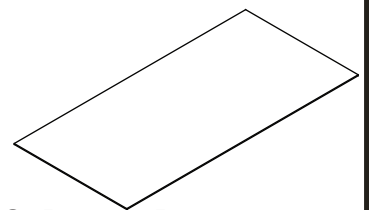

S. Drawer Bottom x3  
Part #21983

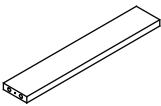

T. Drawer Support x3  
Part #21984

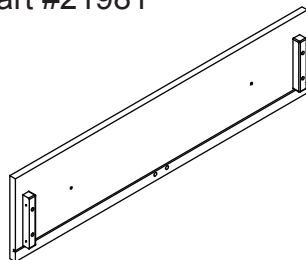

U. Drawer Front x3  
Part #21985

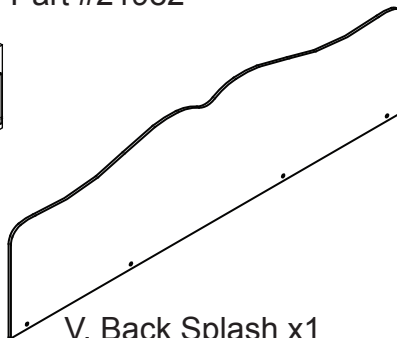

V. Back Splash x1  
Part #21987

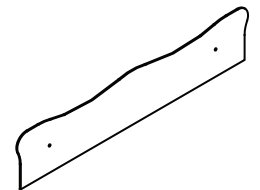

W. Drawer Art x3  
Part #21986

# PARTS: Hardware and tools required. Hardware Kit Part #21988

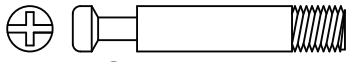

AA. Cam Bolt x33

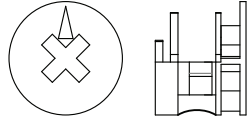

BB. Cam Lock x33



CC. 30mm Wood Dowel x46

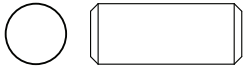

DD. 20mm Wood Dowel x2

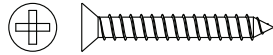

EE. 25mm Screw x7

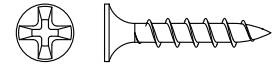

FF. 22mm Screw x15



GG. 38mm Screw x12

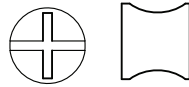

HH. Plastic Barrel Nut x12



JJ. Back panel Screw x6

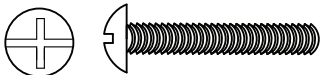

KK. Knob Screw x6

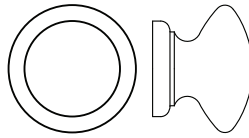

LL. Knob x6  
Part #: 21990

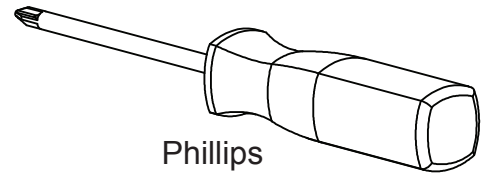

Phillips  
Screwdriver Supplied

## How to use cam lock system:

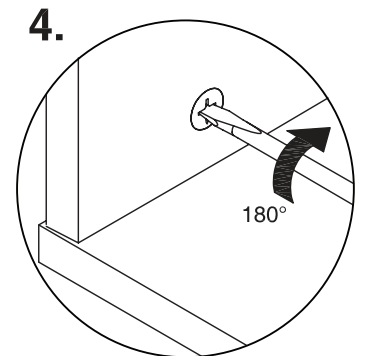
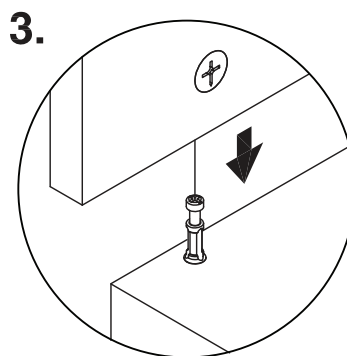
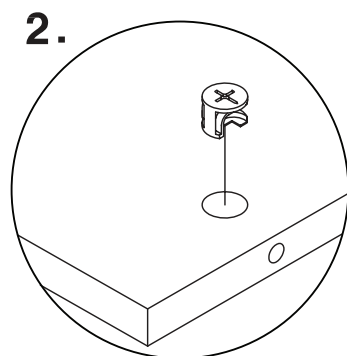
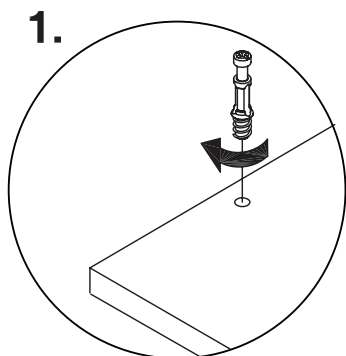

# STEP 1:

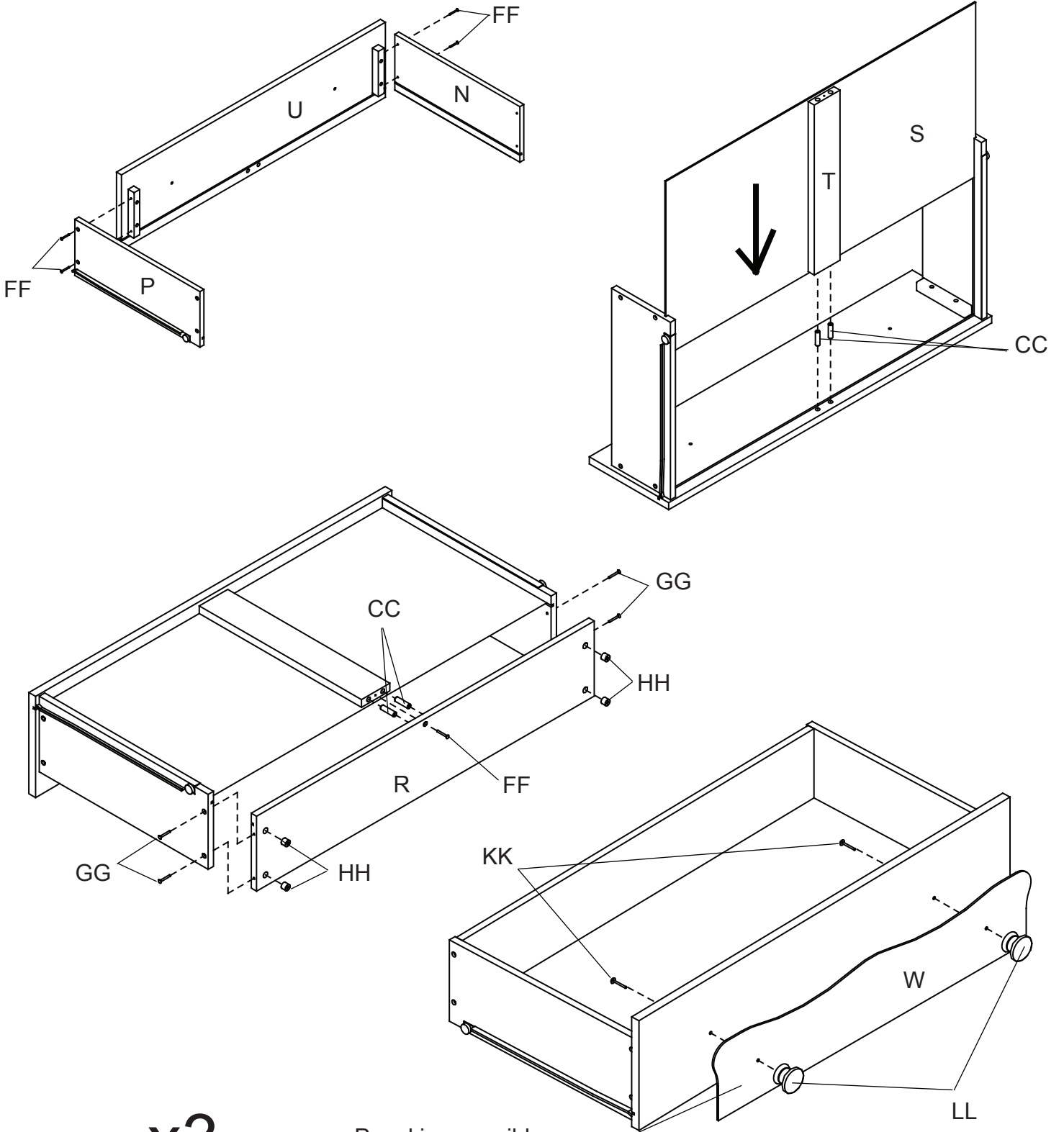
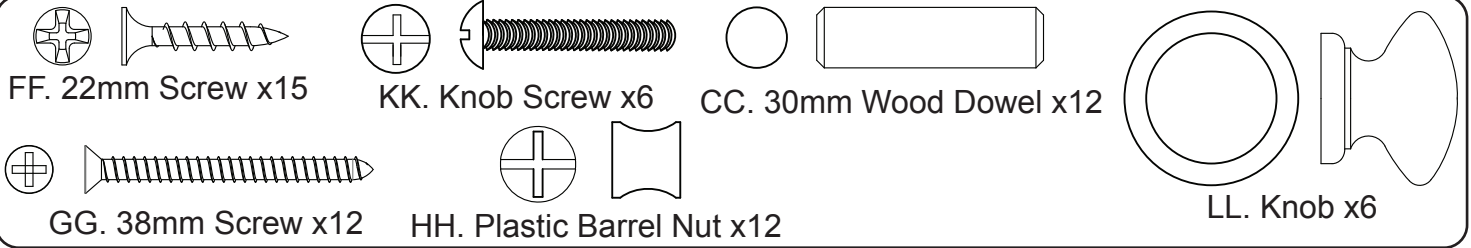

**x3**

Panel is reversible  
 Panel est réversible  
 Panel es reversibile

## STEP 2:

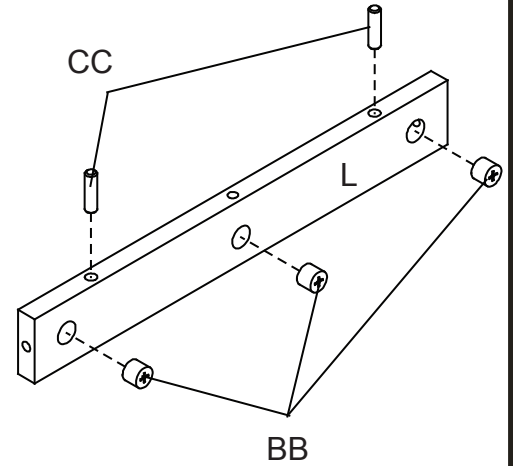
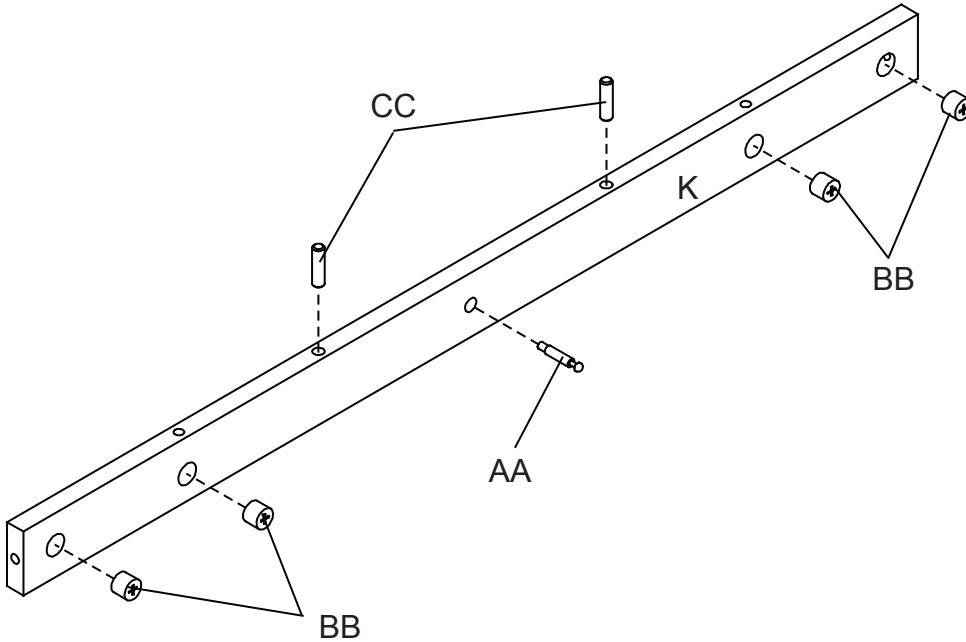
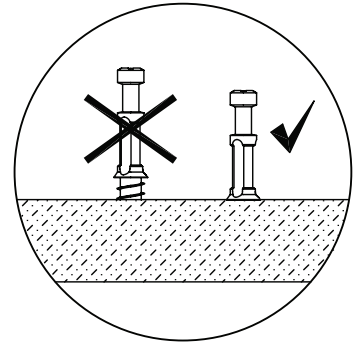
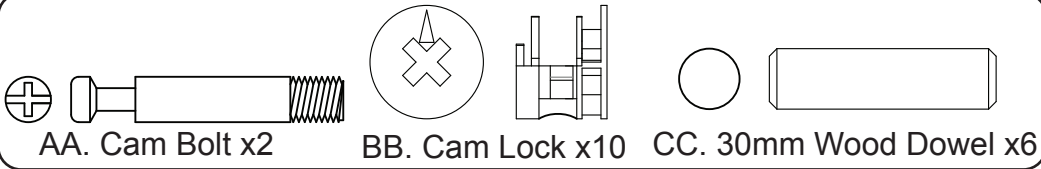

## STEP 3:

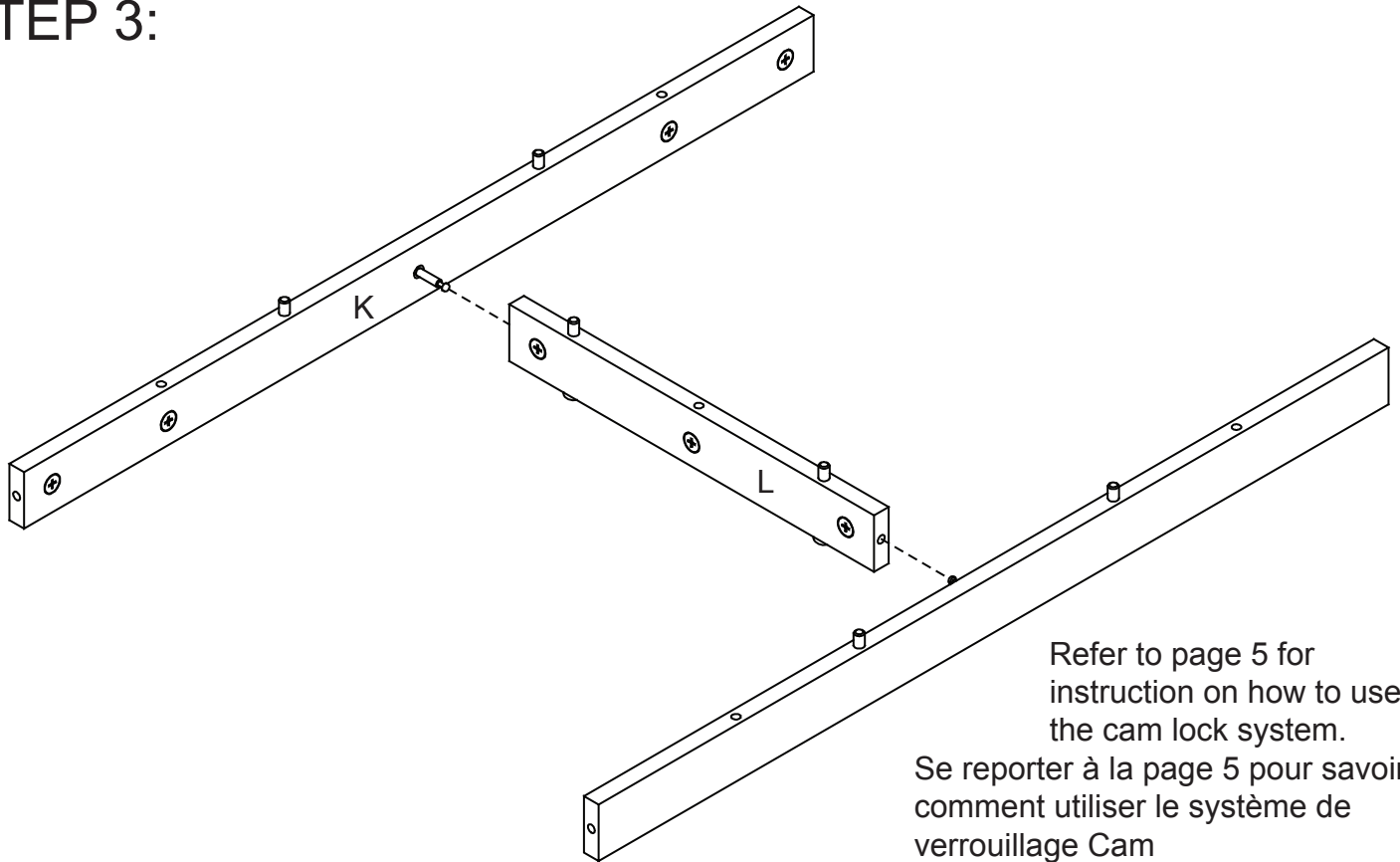

Refer to page 5 for instruction on how to use the cam lock system.

Se reporter à la page 5 pour savoir comment utiliser le système de verrouillage Cam

Consulte la página 5 para obtener información sobre cómo utilizar el sistema cerradura Cam

## STEP 4:

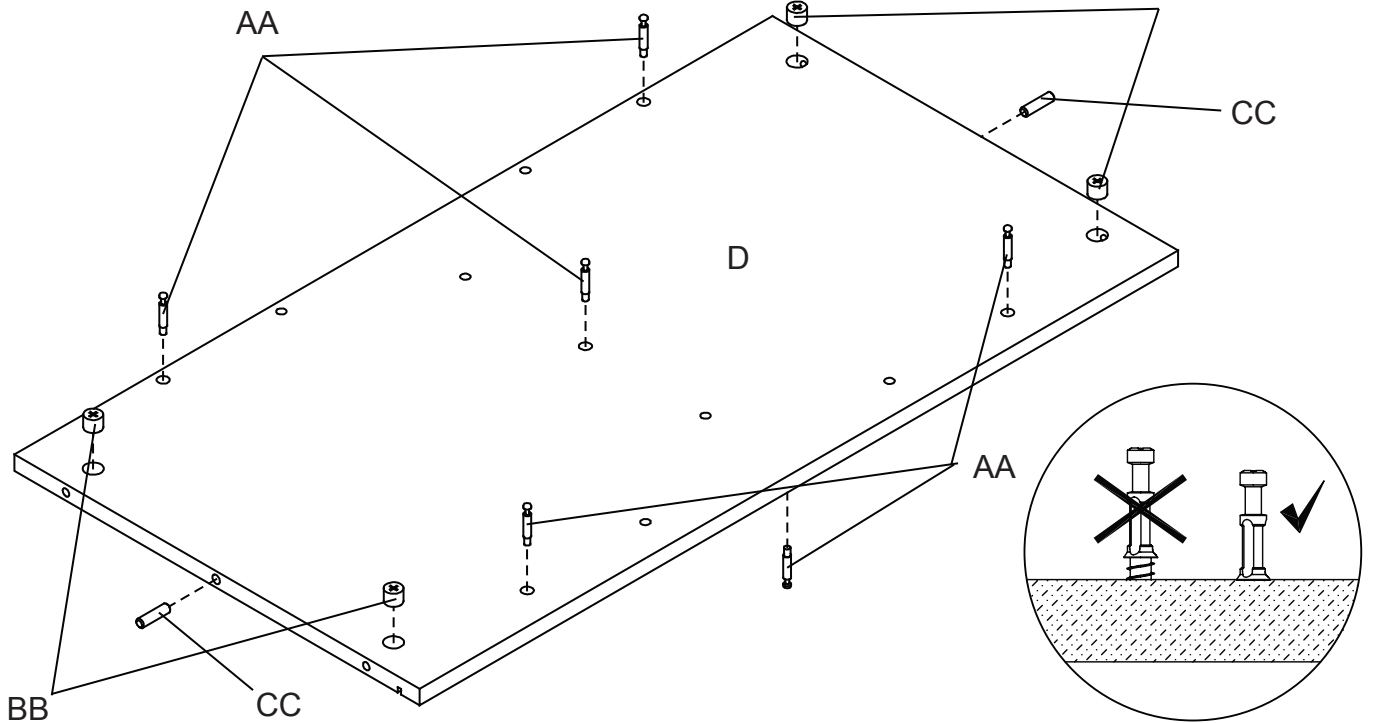
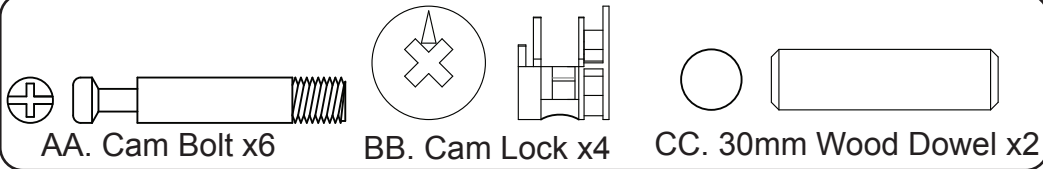

## STEP 5:

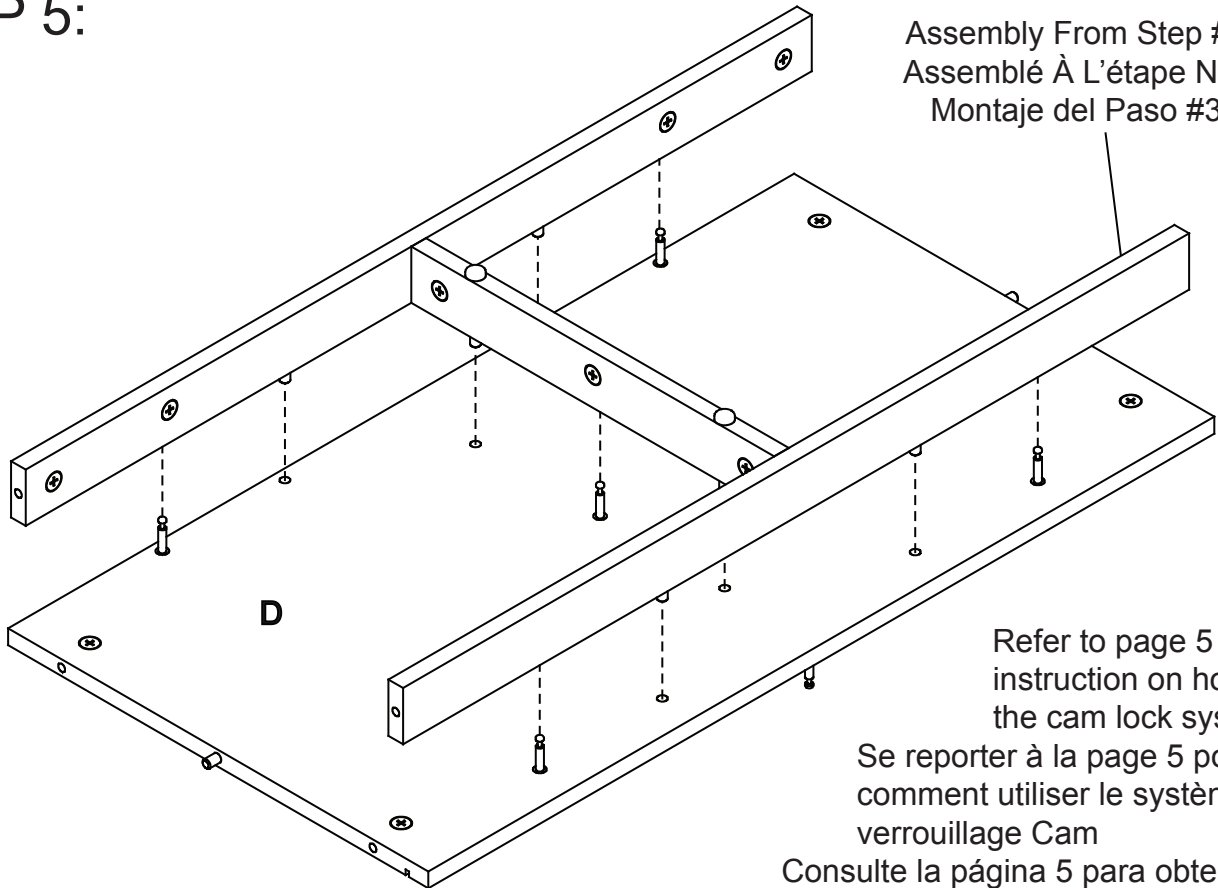

Assembly From Step #3  
Assemblé À L'étape N°3  
Montaje del Paso #3

Refer to page 5 for  
instruction on how to use  
the cam lock system.

Se reporter à la page 5 pour savoir  
comment utiliser le système de  
verrouillage Cam

Consulte la página 5 para obtener  
información sobre cómo utilizar el  
sistema cerradura Cam



## STEP 6:

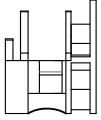

BB. Cam Lock x3

CC. 30mm Wood Dowel x6

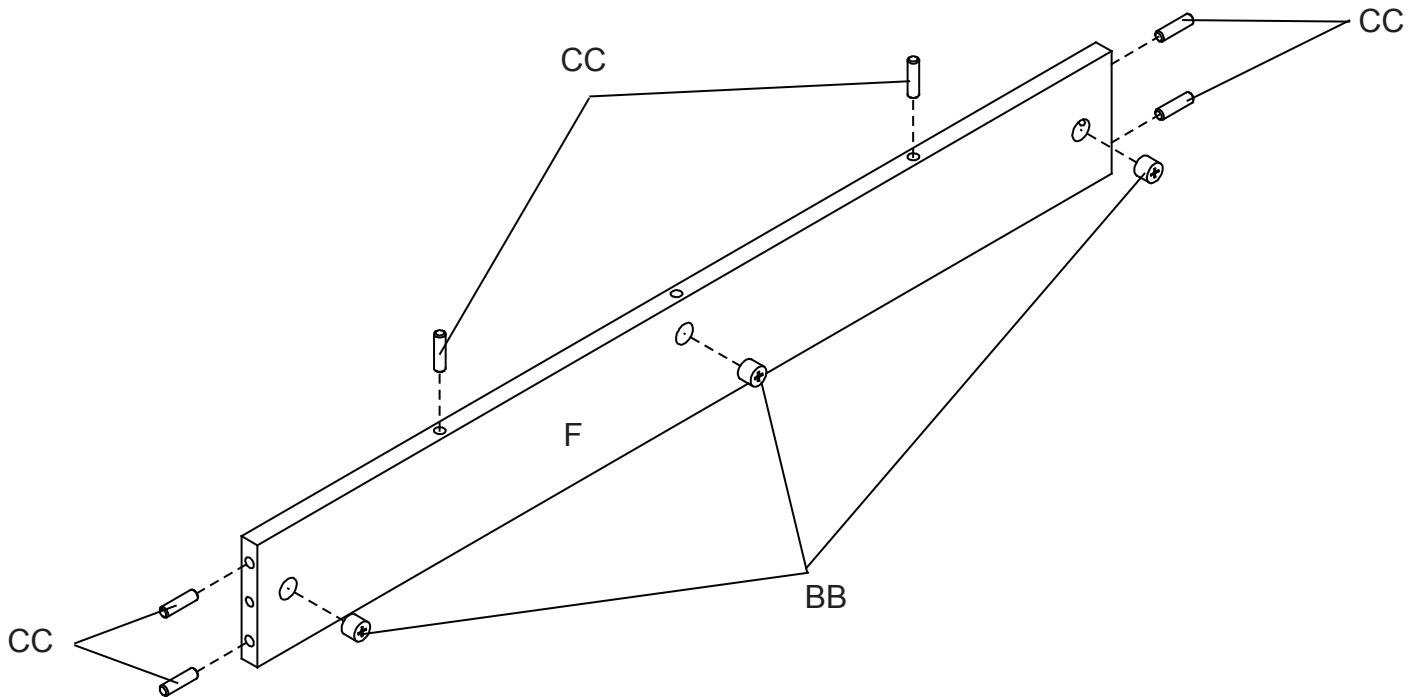

## STEP 7:

Assembly From Step #5  
Assemblé À L'étape N°5  
Montaje del Paso #5

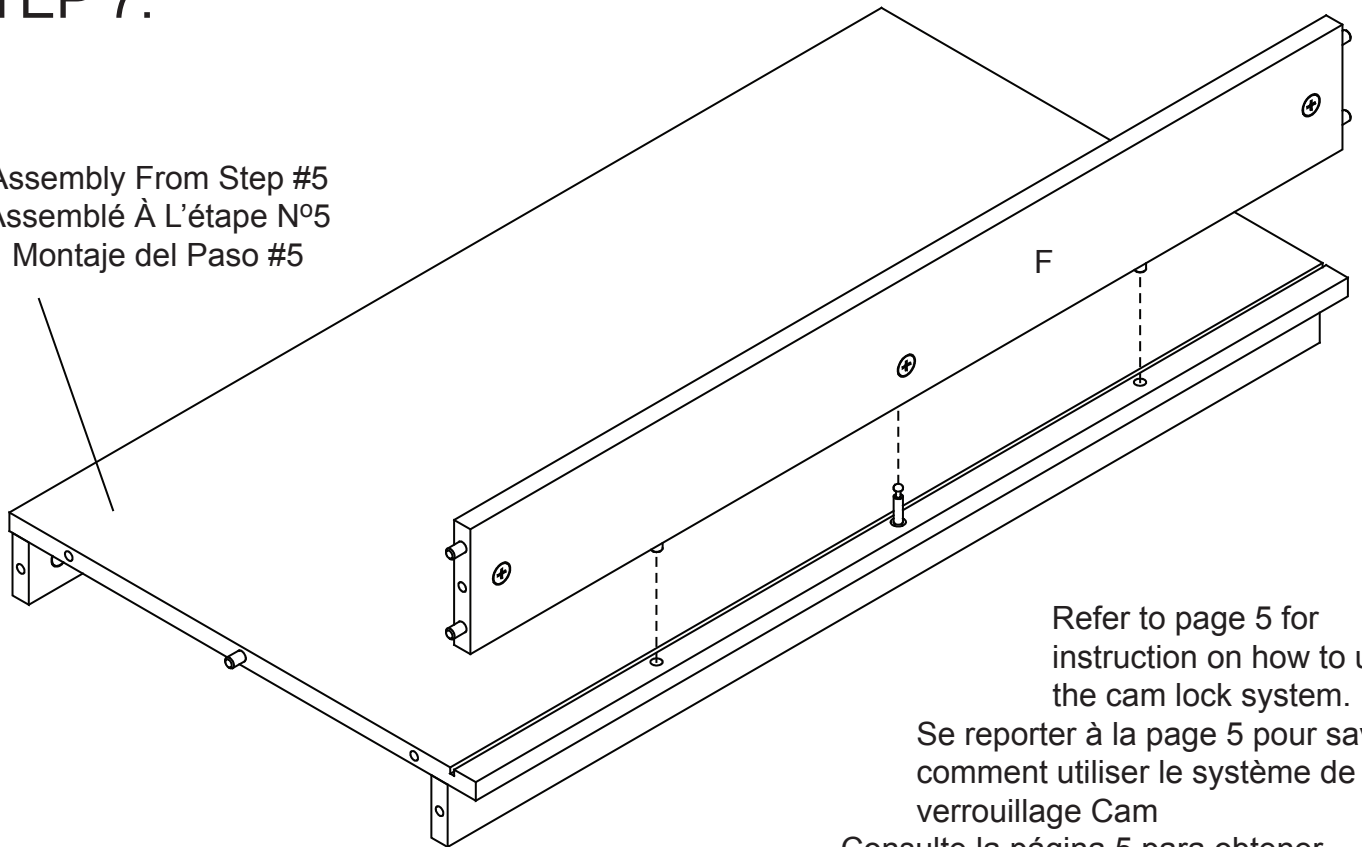

Refer to page 5 for  
instruction on how to use  
the cam lock system.

Se reporter à la page 5 pour savoir  
comment utiliser le système de  
verrouillage Cam

Consulte la página 5 para obtener  
información sobre cómo utilizar el  
sistema cerradura Cam

# STEP 8:

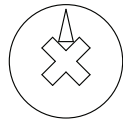

BB. Cam Lock x9

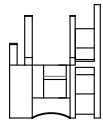

CC. 30mm Wood Dowel x14

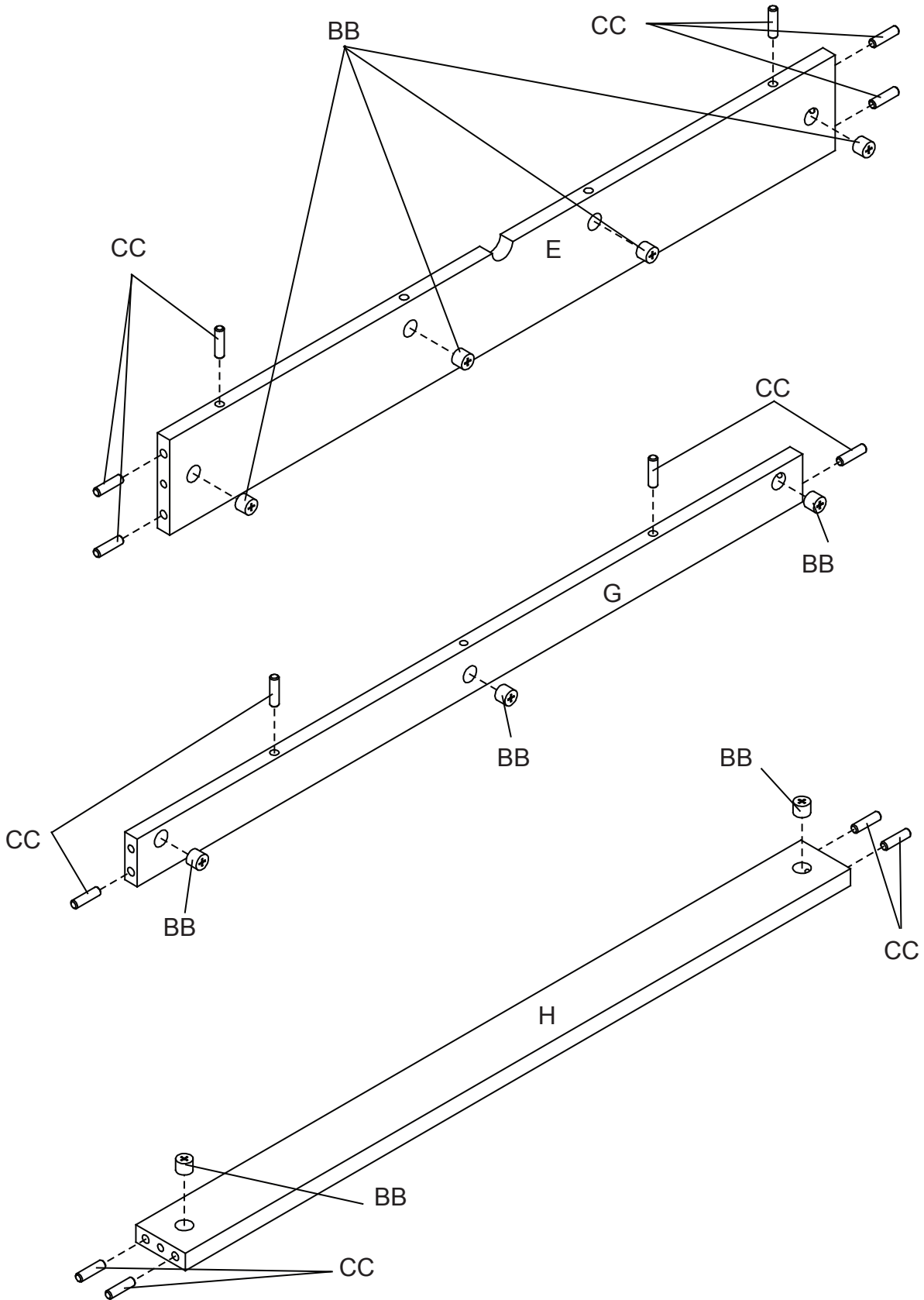

# STEP 9:

AA. Cam Bolt x18      BB. Cam Lock x4      CC. 30mm Wood Dowel x2

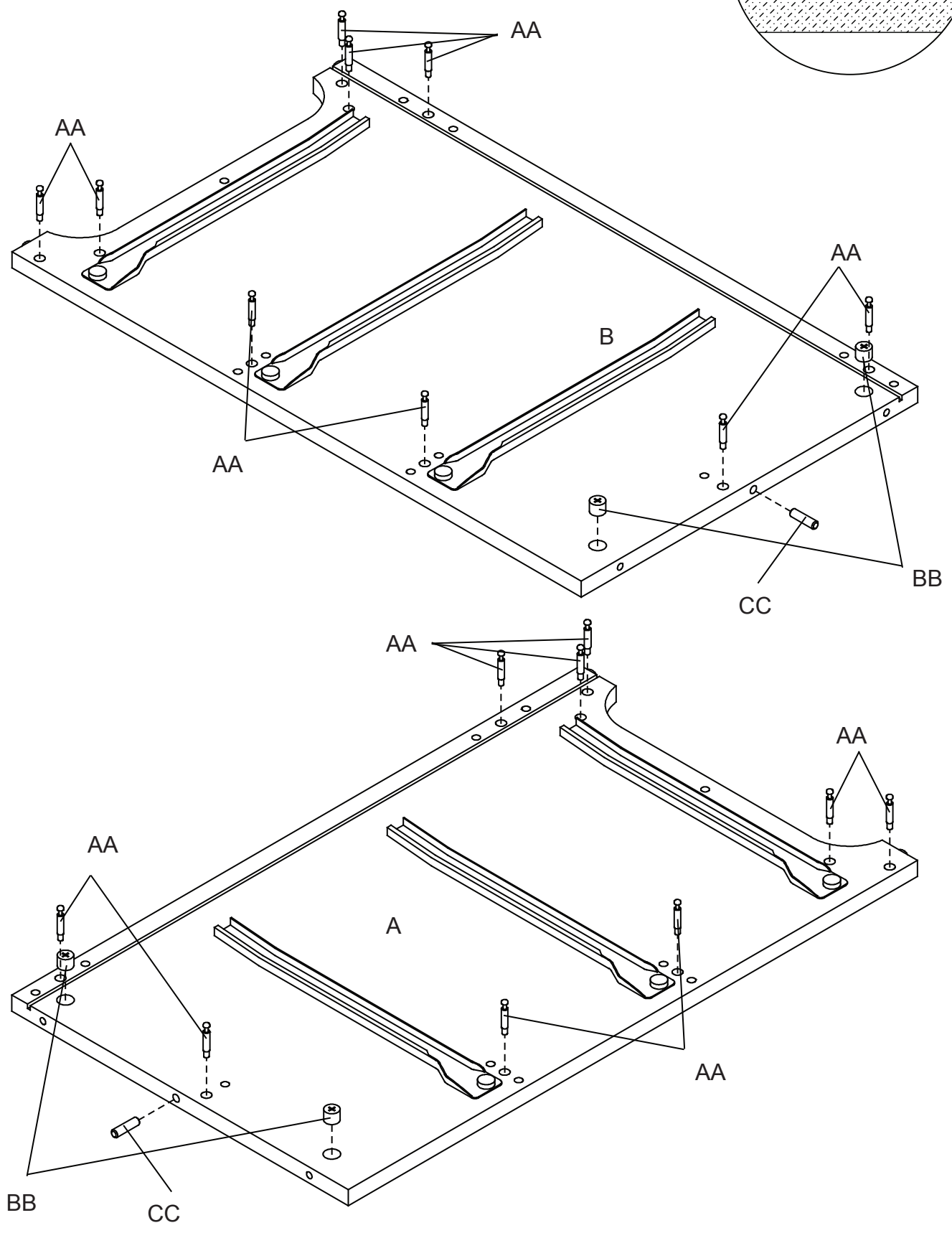
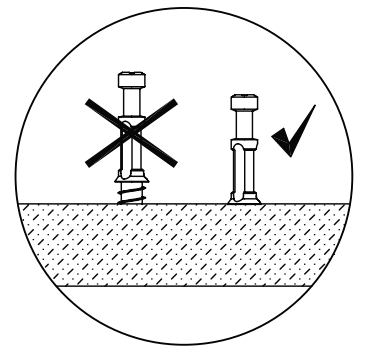

## STEP 10:

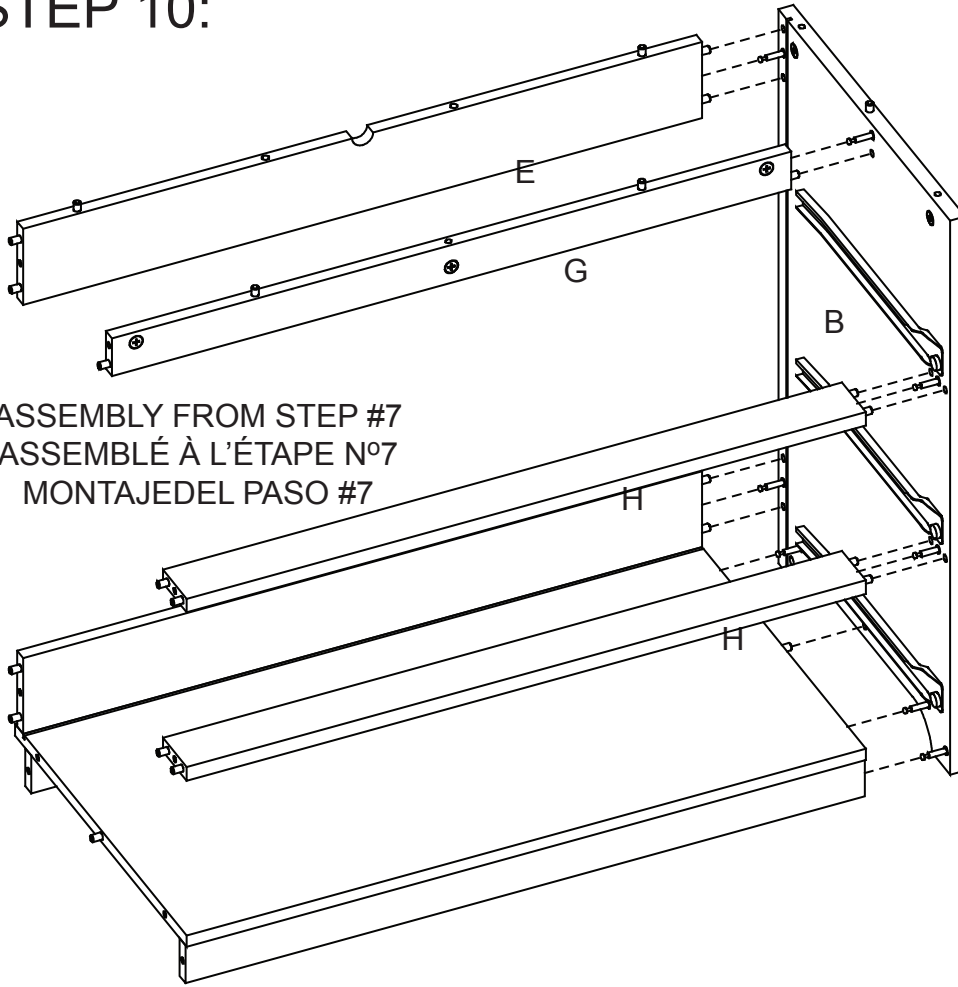

ASSEMBLY FROM STEP #7  
ASSEMBLÉ À L'ÉTAPE N°7  
MONTAJE DEL PASO #7

Refer to page 5 for instruction on how to use the cam lock system.

Se reporter à la page 5 pour savoir comment utiliser le système de verrouillage Cam  
Consulte la página 5 para obtener información sobre cómo utilizar el sistema cerradura Cam

## STEP 11:

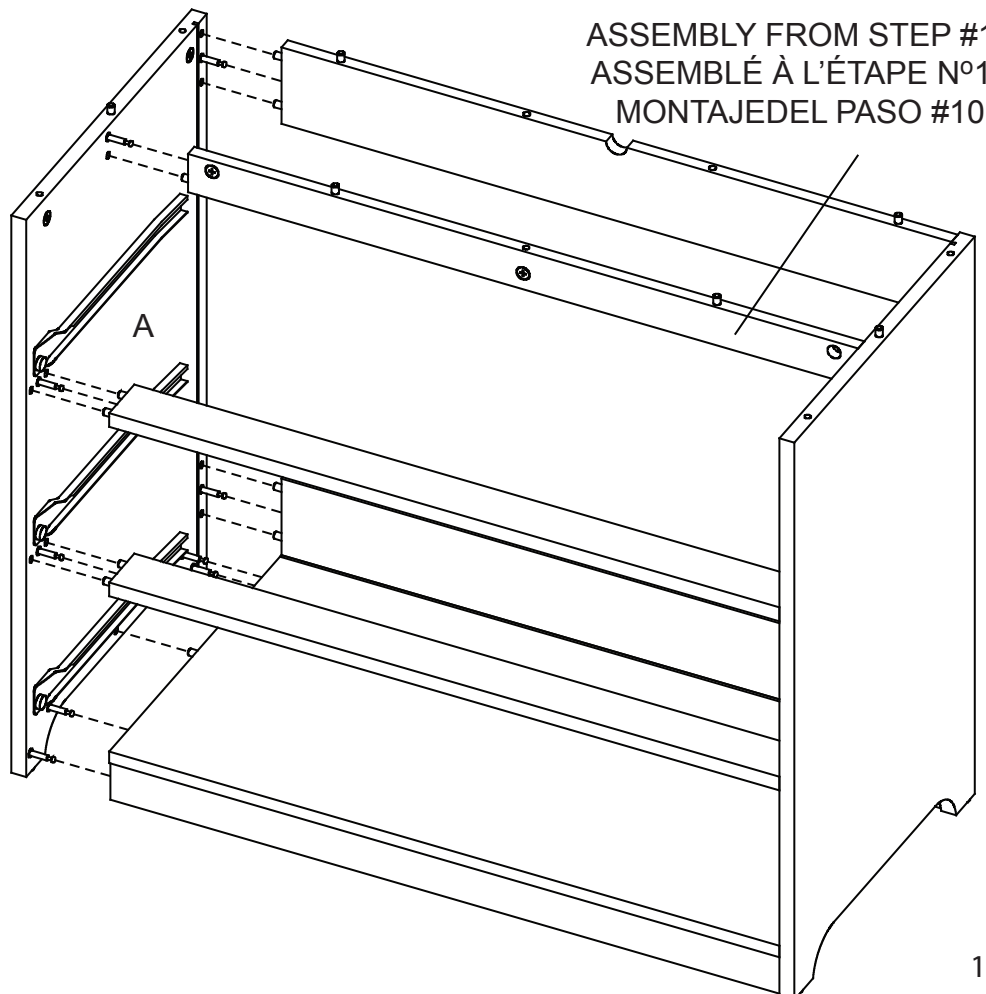

ASSEMBLY FROM STEP #10  
ASSEMBLÉ À L'ÉTAPE N°10  
MONTAJE DEL PASO #10

Refer to page 5 for instruction on how to use the cam lock system.

Se reporter à la page 5 pour savoir comment utiliser le système de verrouillage Cam  
Consulte la página 5 para obtener información sobre cómo utilizar el sistema cerradura Cam

## STEP 12:

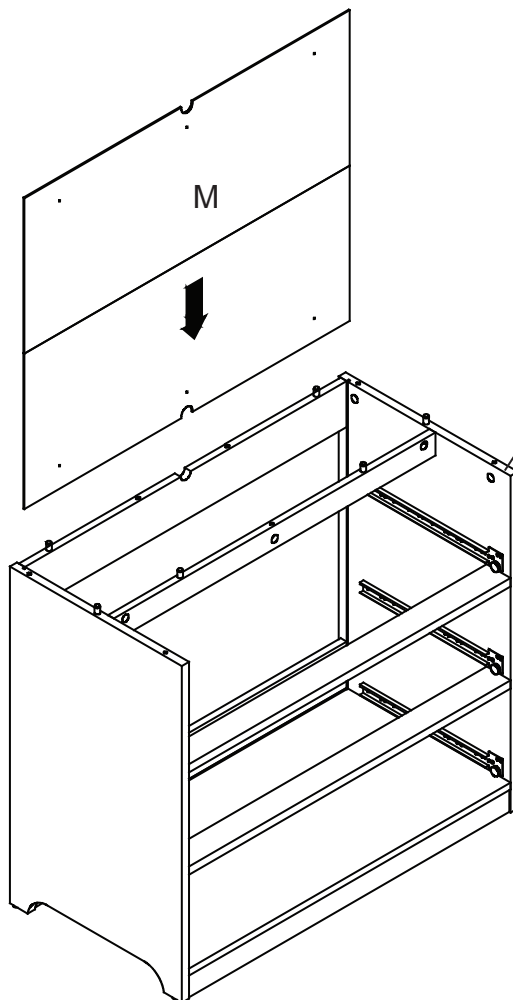

Assembly From Step #11  
Assemblé À L'étape N°11  
Montaje del Paso #11



## STEP 13:

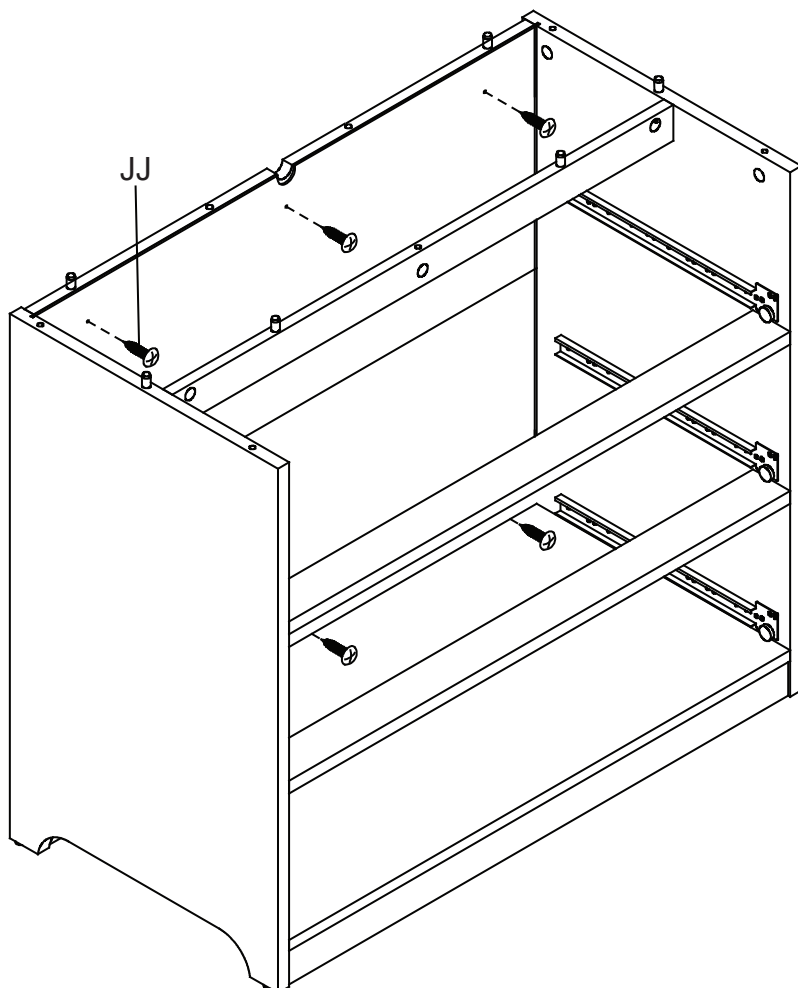

JJ. Back panel Screw x6



# STEP 14:

 AA. Cam Bolt x7  
 DD. 20mm Wood Dowel x2  
 EE. 25mm Screw x4

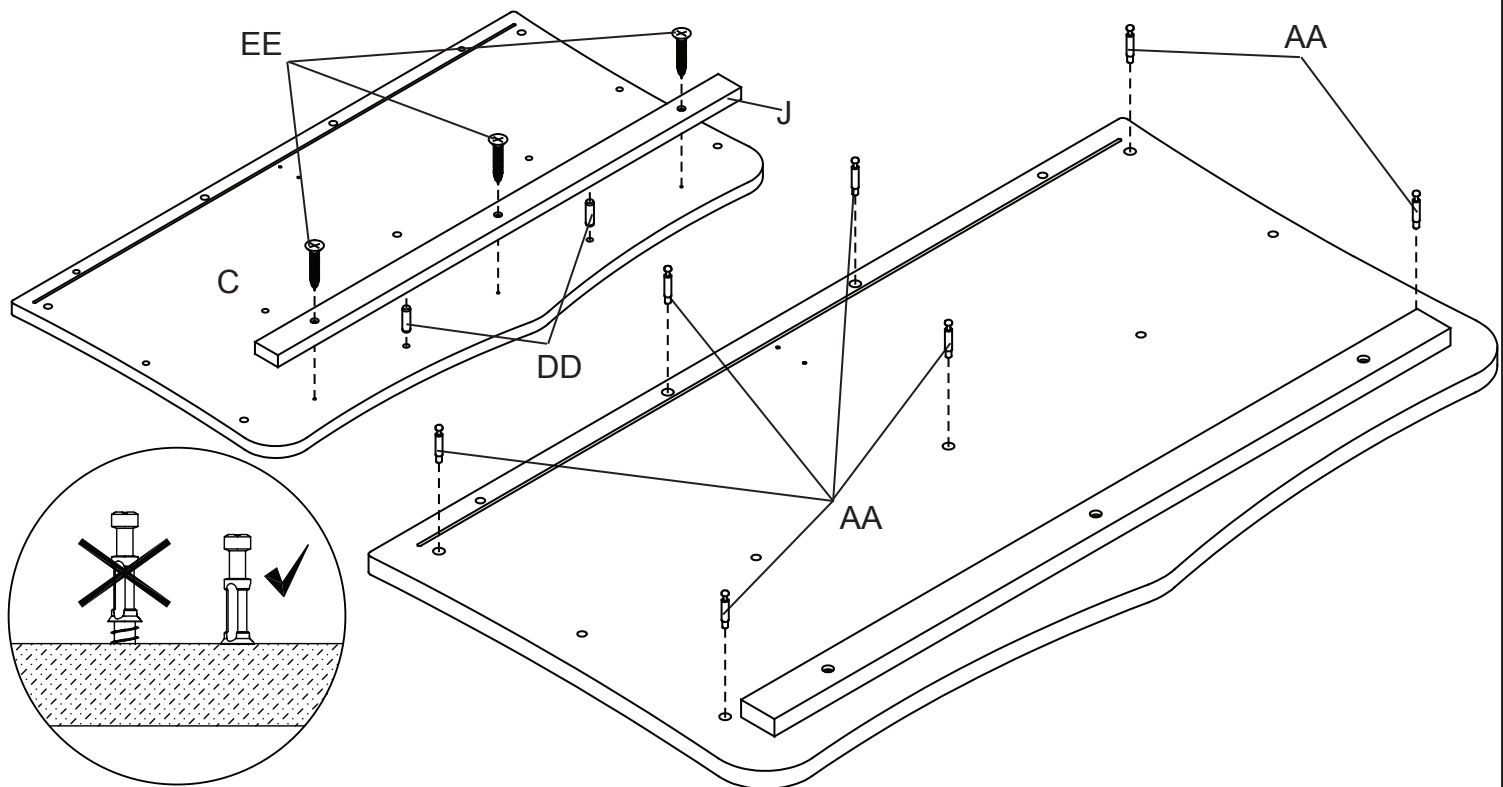

# STEP 15:

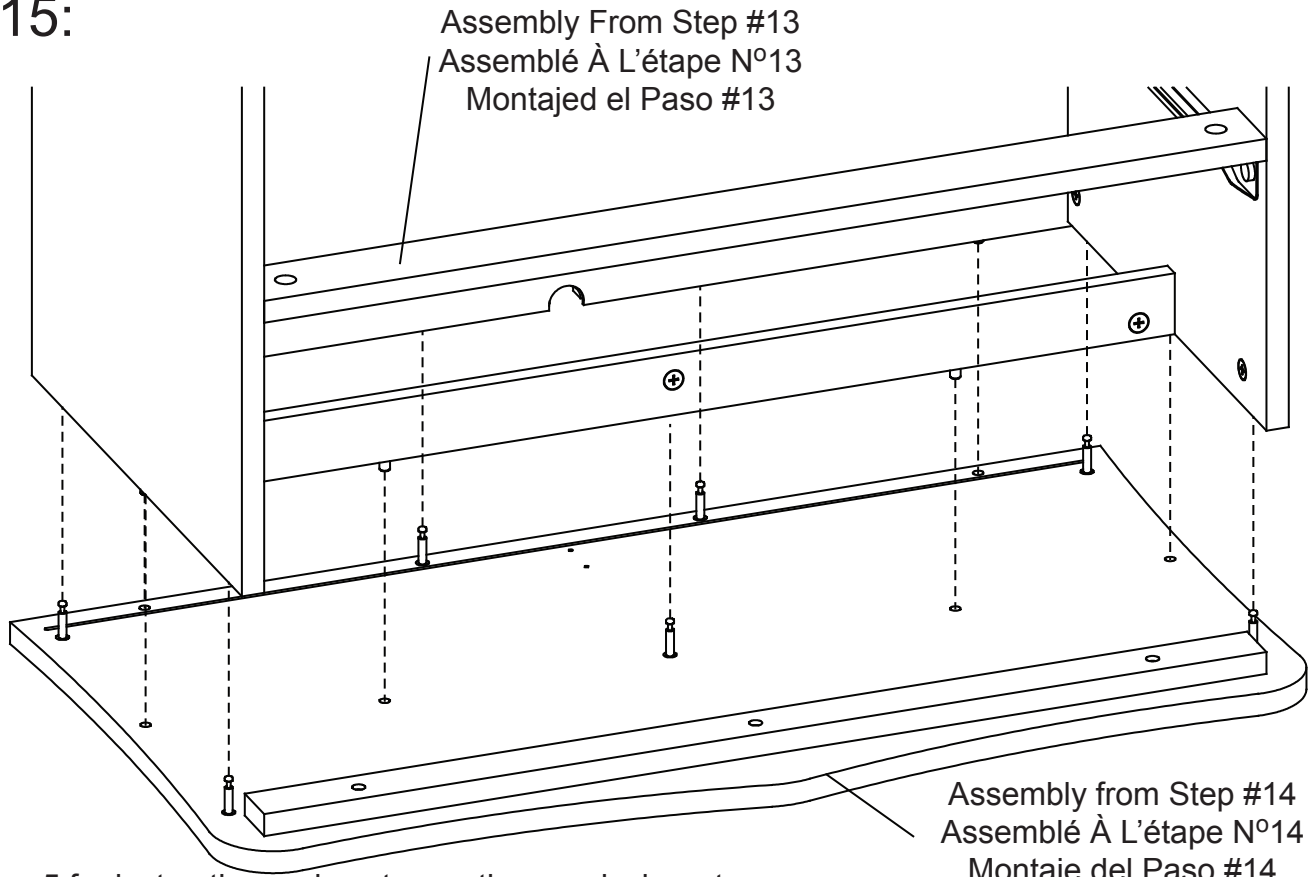

Refer to page 5 for instruction on how to use the cam lock system.  
 Se reporter à la page 5 pour savoir comment utiliser le système de verrouillage Cam  
 Consulte la página 5 para obtener información sobre cómo utilizar el sistema cerradura Cam

# STEP 16:

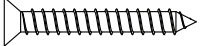
   
EE. 25mm Screw x4

Panel is reversible  
Panel est réversible  
Panel es reversible

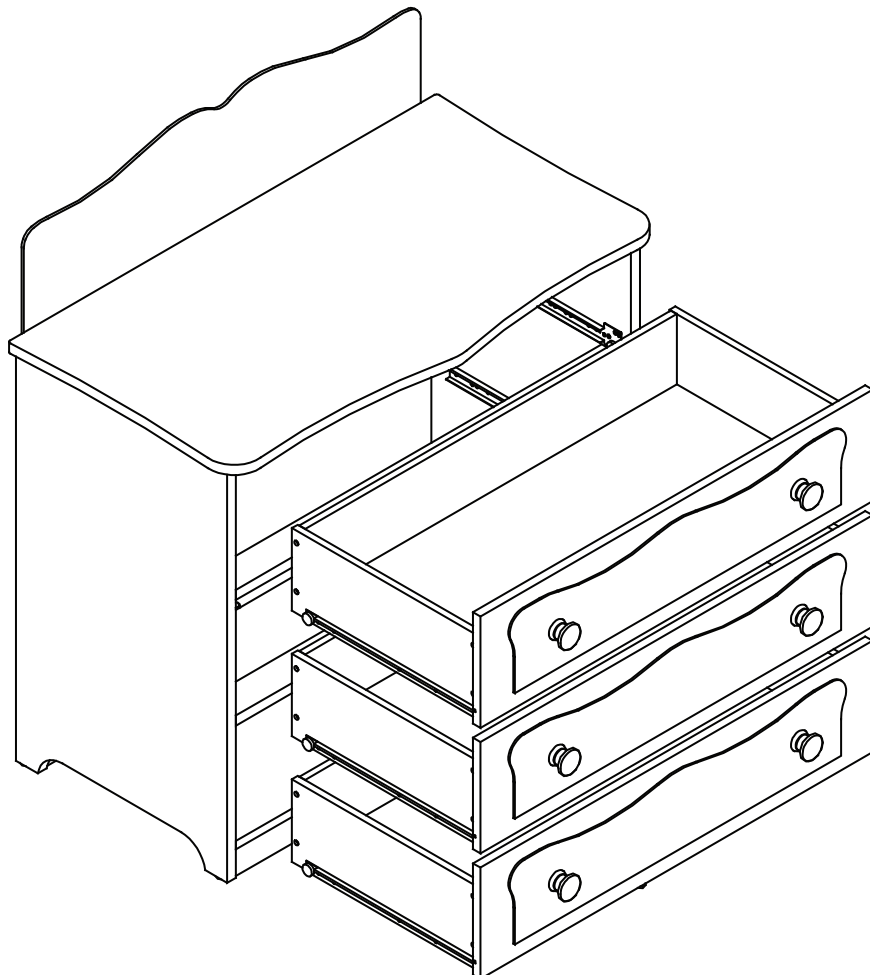
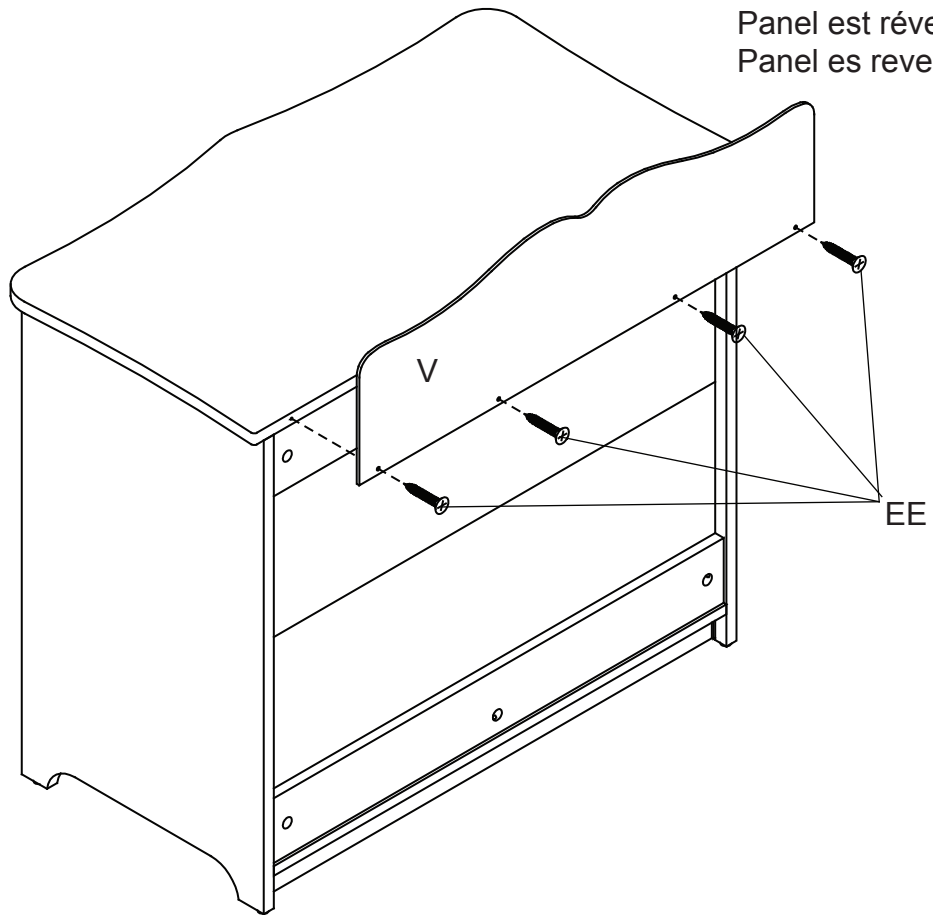

# Delta™

**Children's Products**

Consumer Care:

[www.DeltaChildren.com](http://www.DeltaChildren.com)

Delta Children's Products

114 West 26th Street

New York, NY 10001

Tele.212-645-9033

**Warranty:** This Delta Case is warranted to be free from defects for a period of 90 days from the date of purchase under normal use. This warranty extends only to the original retail purchaser and is valid only when supplied with proof of purchase, or if received as a gift, when the registration is on file with Delta.

Please visit [www.DeltaChildren.com](http://www.DeltaChildren.com) and click on Product Registration to register your product for important safety alerts and updates.

For questions or comments, please log on to [www.DeltaChildren.com](http://www.DeltaChildren.com) and click Consumer Care, or contact us by phone at (212) 645-9033.

In the event that you need to contact our Consumer Care department please have the Style Number and Lot Number available. If they are not printed below they can be found on the label on the Back panel.

Use the space below to make note of those numbers.

**STYLE No: FL86864PS**

COLOR

REV

FACTORY

Lot No. : \_\_\_\_\_

Pack Date: \_\_\_\_\_

Date of Purchase: \_\_\_\_\_ (you should also keep your receipt)