

READ ALL INSTRUCTIONS BEFORE
ASSEMBLY AND USE.

KEEP INSTRUCTIONS FOR FUTURE USE.

⚠ ADULT ASSEMBLY REQUIRED

DUE TO THE PRESENCE OF SMALL PARTS
DURING ASSEMBLY, KEEP OUT OF REACH OF
CHILDREN UNTIL ASSEMBLY IS COMPLETE.

www.jpma.org

**JPMA
CERTIFIED**

Conforms to
ASTM F1169,
F1821 & F2388
Safety Standards

DeltaTM
Children's Products

Customer Service:

Web Site: www.deltachildrenproducts.com

Delta Children's Products

114 West 26th Street

New York, NY 10001

Tele. 212-645-9033

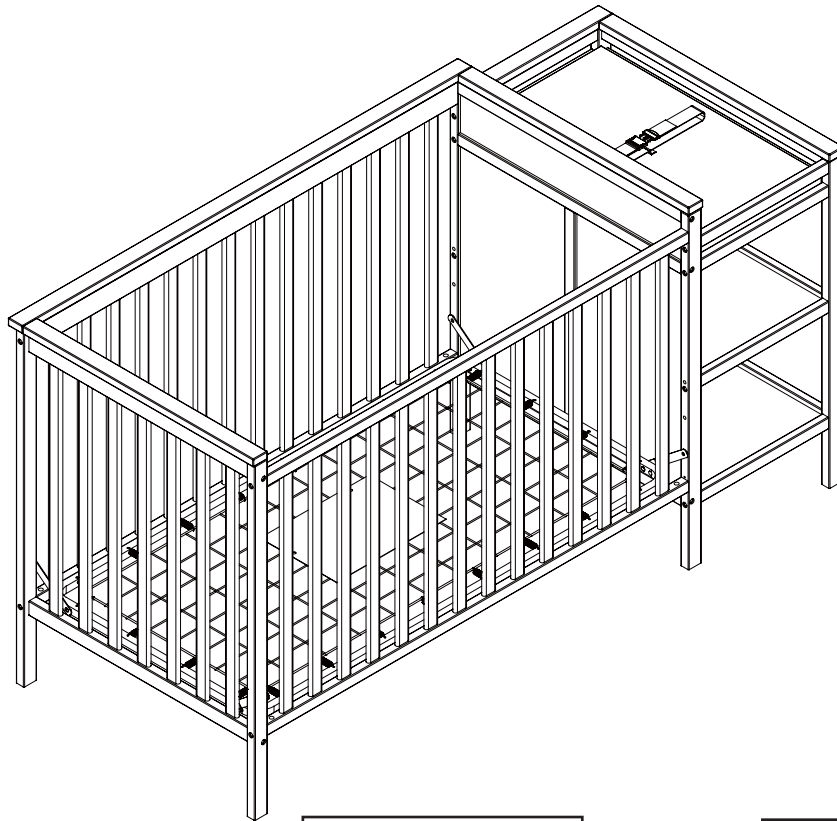

STYLE No: 75001

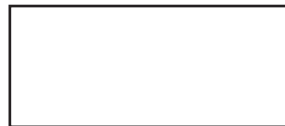

COLOR



REV



FTY

THIS PRODUCT IS NOT INTENDED FOR INSTITUTIONAL OR COMMERCIAL USE.

If you have any questions or missing parts, contact us. DO NOT return product parts to the store from where it was purchased before contacting Delta Children's Products Customer Service. Make sure that all preassemble parts are tight. The appearance of your product may be different from that pictured in this booklet.

To register your product for important safety alerts and updates to your product please visit <http://deltaenterprise.com/register.asp>

⚠CAUTION: ANY MATTRESS USED IN THIS CRIB MUST BE AT LEAST 27 1/4 INCHES BY 51 5/8 INCHES WITH A THICKNESS NOT EXCEEDING 6 INCHES.

⚠WARNING: CRIB

Infants can suffocate on soft bedding. Never add a pillow or comforter. Never place additional padding under an infant.

Failure to follow these warnings and the assembly instructions could result in serious injury or death.

To reduce the risk of SIDS, pediatricians recommend healthy infants be placed on their backs to sleep, unless otherwise advised by your physician.

ADULT ASSEMBLY REQUIRED DUE TO SMALL PARTS.

*Read all instructions before assembling crib. **KEEP INSTRUCTIONS FOR FUTURE USE.**

***Strangulation Hazard:** STRINGS CAN CAUSE STRANGULATION! **Do not** place items with a string around a child's neck, such as hood strings or pacifier cords. **Do not** suspend strings over a crib or attach strings to toys.

***Strangulation Hazard:** To help prevent strangulation tighten all fasteners. A child can trap parts of the body or clothing on loose fasteners.

***Strangulation Hazard:** **Do not** place crib near window where cords from blinds or drapes may strangle a child.

***Fall Hazard:** When child is able to pull to a standing position, set mattress to lowest position and remove bumper pads, large toys and other objects that could serve as steps for climbing out. This crib has an adjustable mattress support. For the convenience of the parent when the baby is very small, the mattress support may be used in the highest position. Important: with the mattress support and mattress in the highest position, be absolutely sure that the top of the front crib side is at least 3 inches higher than the top surface of the mattress. If it is not, lower the mattress support and the mattress to the next highest position.

***Fall Hazard:** Stop using crib when child begins to climb out or reaches a height of 35in. (90cm), whichever occurs first. The child should be placed in a youth or regular bed.

*Check this product for damaged hardware, loose joints, missing parts or sharp edges before and after assembly and frequently during use. **Do not use crib** if any parts are missing, damaged or broken. Contact Delta Children's Products for replacement parts and instructional literature if needed. Do not substitute parts.

*Follow warnings on **all** products in a crib.

***Do not** use a water mattress with this crib.

*If refinishing, use a non-toxic finish specified for children's products.

***Never** use plastic shipping bags or other plastic film as mattress covers because they can cause suffocation.

*Infants can suffocate in gaps between crib sides and a mattress that is too small.

*Ensure a safe environment for the child by checking regularly, before placing the child in the crib, that every component is properly and securely in place.

*To avoid head injury, do not allow any child to play underneath the crib.

***Never** add an accessory such as a bassinet or changing table that extends over the sleeping area.

TODDLER BED

WARNING ENTRAPMENT/STRANGULATION HAZARD

*INFANTS HAVE DIED IN TODDLER BEDS FROM ENTRAPMENT AND STRANGULATION. Failure to follow these warnings and the assembly instructions could result in serious injury or death.

***Never** use bed with children under 15 months.

***Never** place bed near windows where cords from blinds or drapes may strangle a child.

***Do not** place items with a string, cord, or ribbon around a child's neck, such as hood strings or pacifier cords.

***Do not** suspend strings over a toddler bed for any reason.

*The users maximum weight shall not be greater than 50 lb (22.7kg).

*The mattress intended for use on the bed shall be a full-size crib mattress having minimum dimensions of 51 5/8 in. (1310 mm) in length, 27 1/4 in. (690 mm) in width and 4 in. (100 mm) in thickness.

*Stabilizer bar(s) must be used when converted to a toddler bed.

WARNING: CHANGING TABLE

Fall hazard - to prevent death or serious injury, always keep child within arm's reach.

Read all instructions before use of the changing table.

KEEP THESE INSTRUCTIONS IN A SAFE PLACE FOR FUTURE USE.

Inspect the changing table periodically. **Do not** use the changing table if it is damaged or broken.

Contact Delta Children's Products with any questions.

Tighten all loose screws and bolts before each use.

The maximum recommended weight of the child is 30lbs for the changing table.

Use only the pad provided by Delta Children's Products.

Always secure the pad to the changing surface by inserting the strap through the hole in the middle of the pad. See Instructions.

NOTES ON ASSEMBLY:

-During the assembly process whenever using screws or bolts, check each by placing the screw/bolt on the diagram of the item which is drawn actual size and design. Be sure to use the proper size and shape specified in the instructions.

-To assemble this unit you may be required to place the unit on it's side and face. It is strongly recommended that assembly is done on a soft, non-abrasive surface to avoid damaging the finish.

NOTES ON USE:

Keep children and others safe by following these simple rules:

- **Do not** allow any child to play on furniture
- **Do not** allow climbing on any piece of furniture.
- **Do not** allow hanging from any piece of furniture.
- Always monitor your child's activity when in the nursery.

NOTES ON CARE AND MAINTENANCE:

- **Do not** scratch or chip the finish.
- Inspect the product periodically, contact delta children's products for replacement parts or questions.
- **Do not** store the product or any parts in extreme temperatures and conditions such as a hot attic or a damp, cold basement. These extremes can cause a loss of structural integrity.
- To preserve the luster of the high quality finish on your product, it is recommended to place a doily or felt pad under any items you place on the finish.
- Clean with a damp cloth, then a dry cloth to preserve the original luster and beauty of this fine finish.
- Do not** use abrasive chemicals.
- Do not** spray cleaners directly onto furniture.
- Lift slightly when moving on carpeting to prevent leg breakage.
- Use of a vaporizer near furniture will cause wood to swell and finish to peel.

PARTS: MAKE SURE THAT ALL PRE-ASSEMBLED PARTS ARE TIGHT.

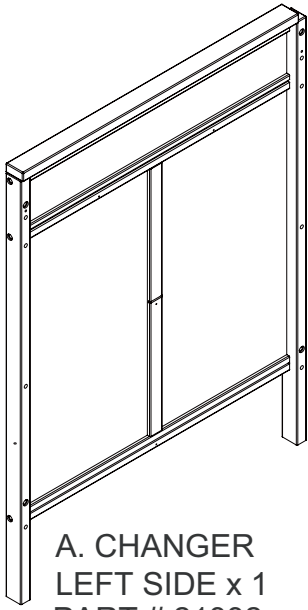

**A. CHANGER
LEFT SIDE x 1
PART # 21332**

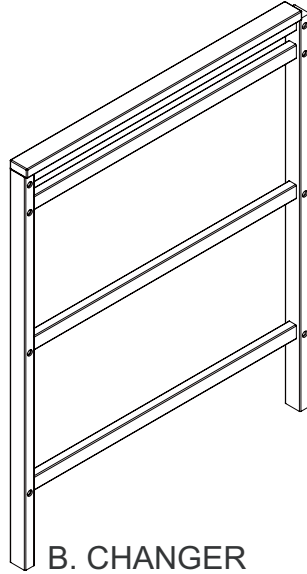

**B. CHANGER
RIGHT SIDE x 1
PART # 21335**

FRONT POST ONLY # 21333
BACK POST ONLY # 21334

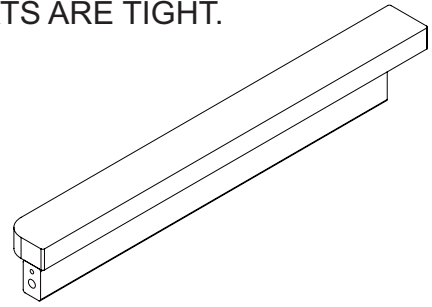

**C. CHANGER BACK RAIL x 1
PART # 21336**

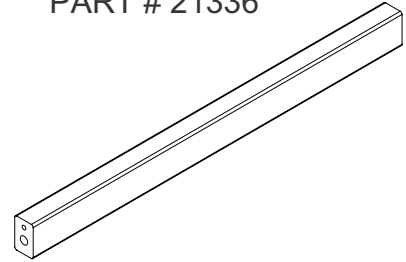

**D. CHANGER FRONT RAIL x 1
PART # 21337**

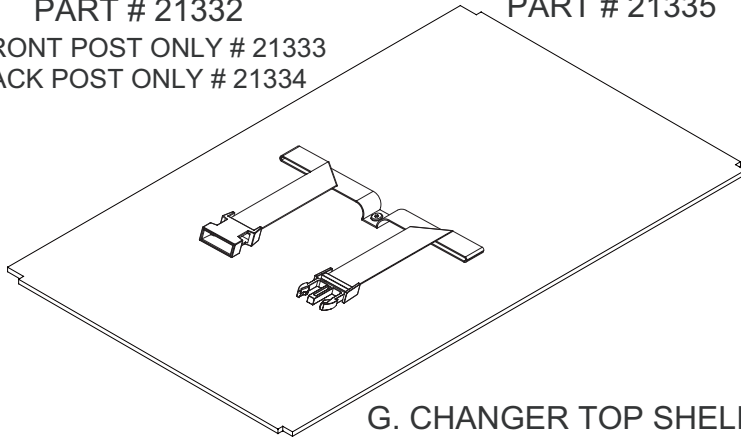

**G. CHANGER TOP SHELF x 1
PART # 21340**

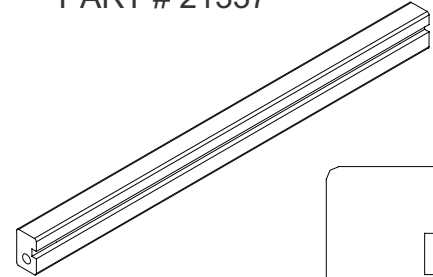

**E. CHANGER WIDE GROOVED
RAIL x 2
PART # 21338**

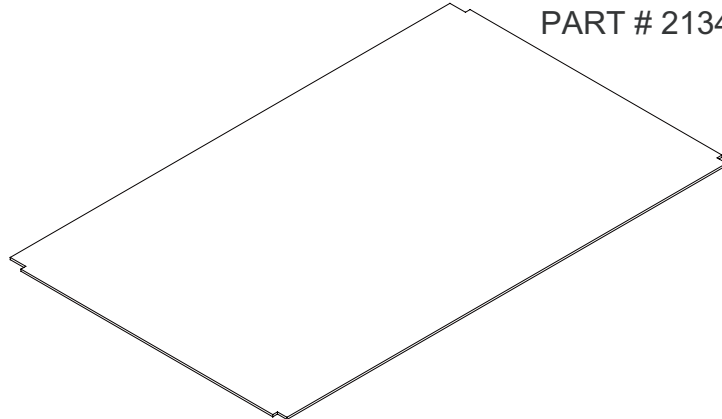
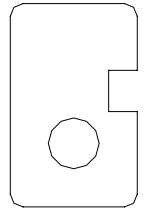

**H. CHANGER LOWER SHELVES x 2
PART # 21341**

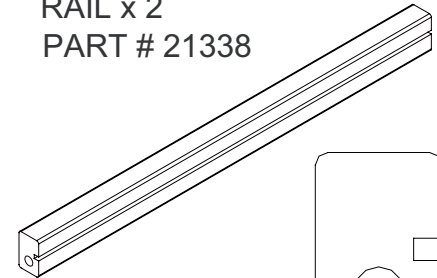

**F. CHANGER GROOVED RAIL x 4
PART # 21339**

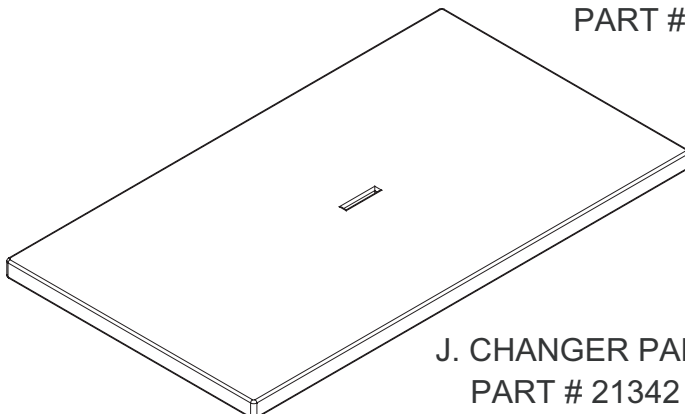
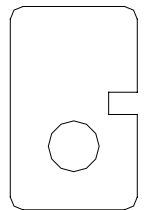

**J. CHANGER PAD x 1
PART # 21342**

PARTS: MAKE SURE THAT ALL PRE-ASSEMBLED PARTS ARE TIGHT.

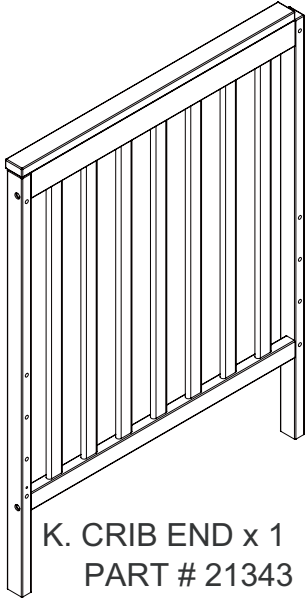

K. CRIB END x 1
PART # 21343

FRONT POST ONLY # 21344
BACK POST ONLY # 21345

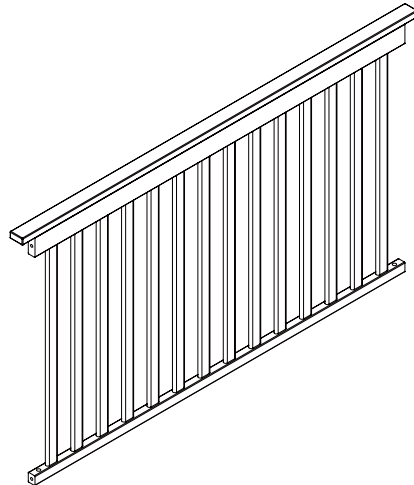

L. CRIB BACK SIDE x 1
PART # 21346

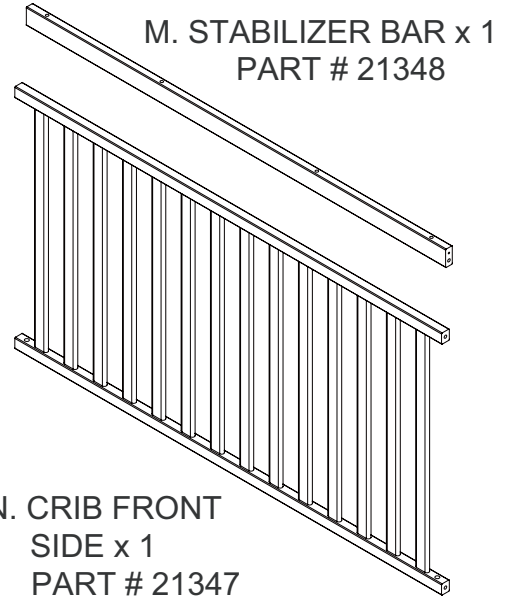

M. STABILIZER BAR x 1
PART # 21348

N. CRIB FRONT
SIDE x 1
PART # 21347

HARDWARE KIT IS PART # 21349 FOR COLOR 205 OR # 21351 FOR COLOR 100. SEE FRONT COVER.

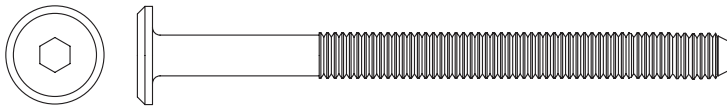

R. M6x76 mm BOLT x 24

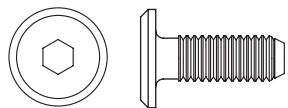

T. M6 x17 mm BOLT x 4

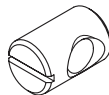

U. BARREL NUT x 24

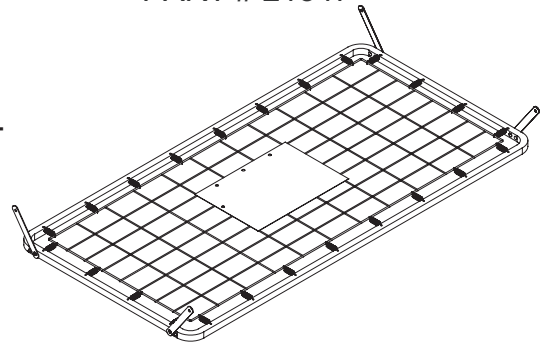

P. MATTRESS SUPPORT x 1
PART # 16945

POUCH ATTACHED TO MATTRESS SUPPORT
- KEEP INSTRUCTIONS IN THIS POUCH
AFTER ASSEMBLY.
WARNINGS RELATED TO THE SAFE USE OF
THIS CRIB ARE PRINTED ON THE POUCH.



V. Φ4x30 mm METAL PIN x 6



W. M4 x12 mm WOOD SCREW x 8

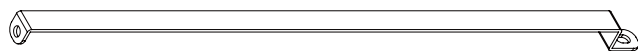

X. SHELF BRACE x 4

Required Tools

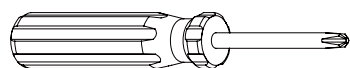

Phillips Screwdriver

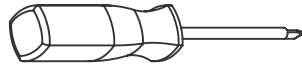

Flat Head Screwdriver
(not supplied)

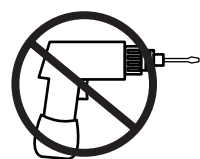

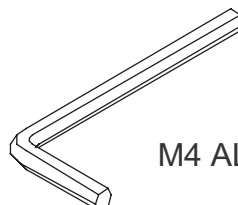

M4 ALLEN WRENCH SUPPLIED

SECTION 1: CHANGING TABLE ASSEMBLY

STEP 1

PARTS AND TOOLS REQUIRED TO COMPLETE STEP

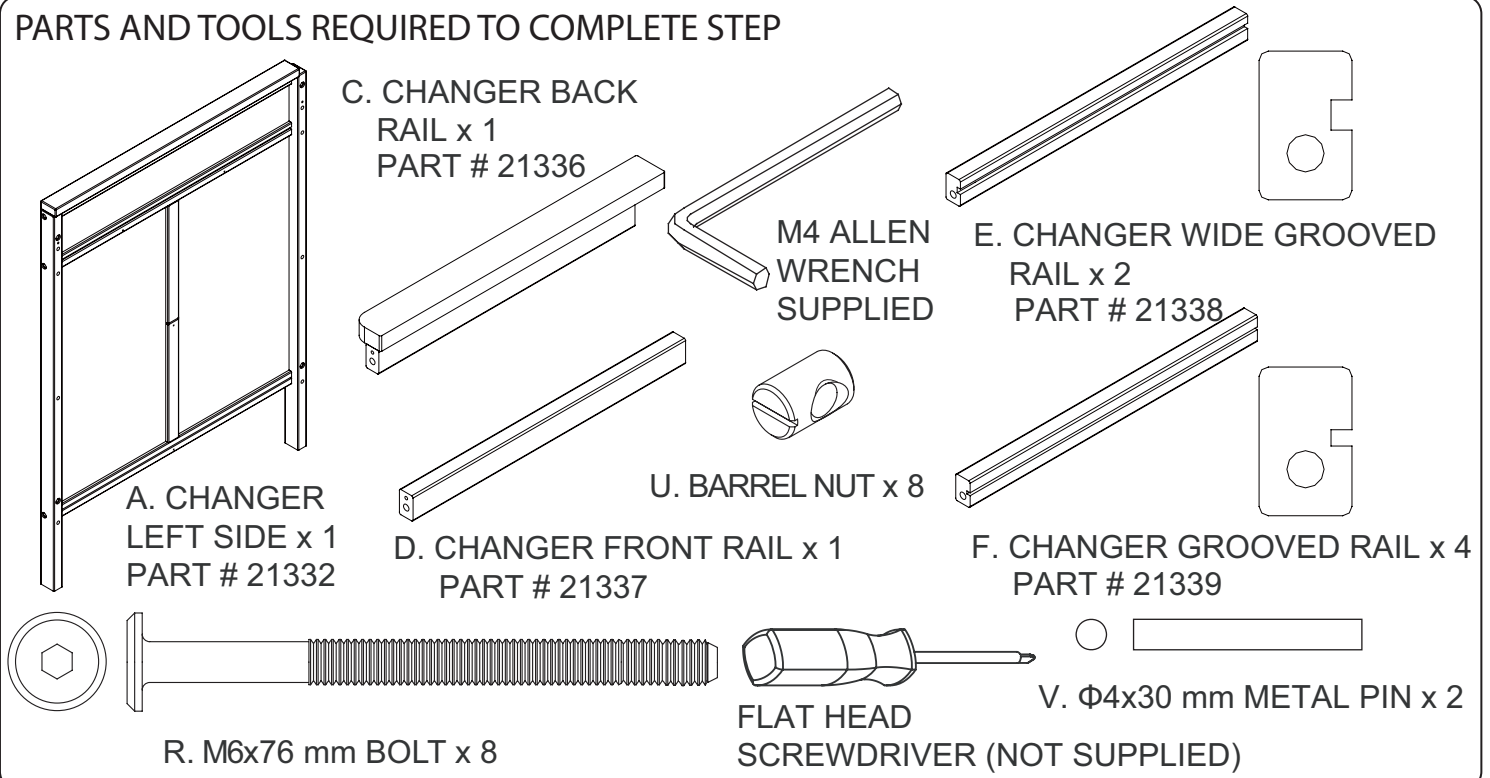

ATTACH (1) CHANGER BACK RAIL (PART C) AND (1) CHANGER FRONT RAIL (PART D) TO THE CHANGER LEFT SIDE (PART A) USING (2) $\Phi 4 \times 30$ mm METAL PINS (PART V), (2) M6x76 mm BOLTS (PART R), AND (2) BARREL NUTS (PART U). ATTACH (2) CHANGER WIDE GROOVED RAILS (PART E) AND (4) CHANGER GROOVED RAILS (PART F) TO THE CHANGER LEFT SIDE USING (6) M6x76 mm BOLTS (PART R), AND (6) BARREL NUTS (PART U). TIGHTEN WITH THE M4 ALLEN WRENCH. USE THE FLAT HEAD SCREWDRIVER TO HOLD THE BARREL NUTS IN PROPER ALIGNMENT.

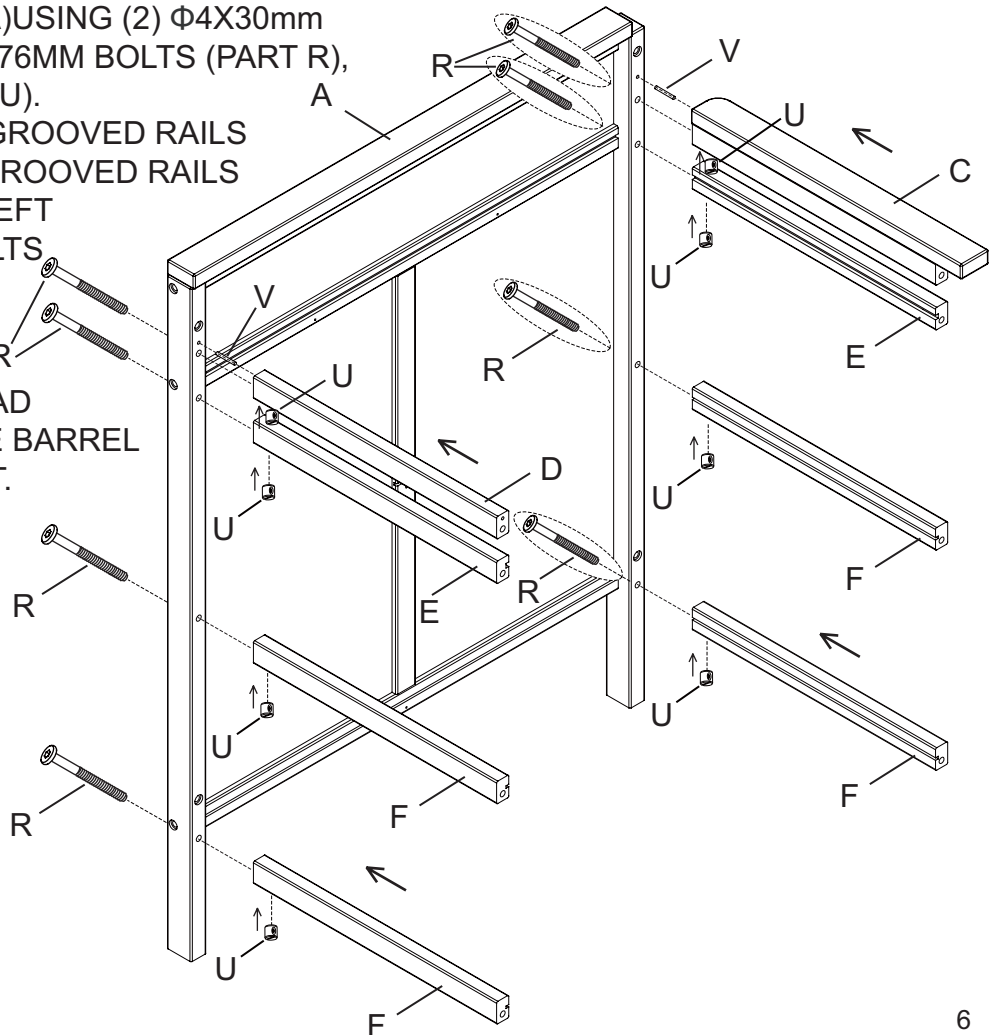
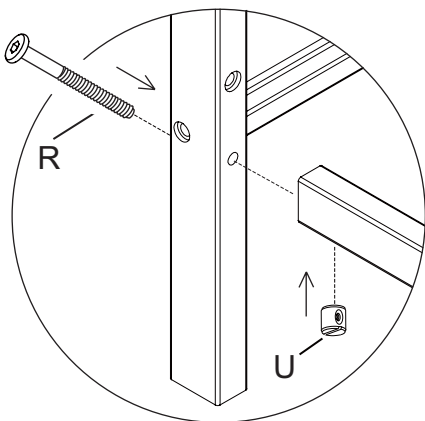

SECTION 1: CHANGING TABLE ASSEMBLY

STEP 2

PARTS AND TOOLS REQUIRED TO COMPLETE STEP

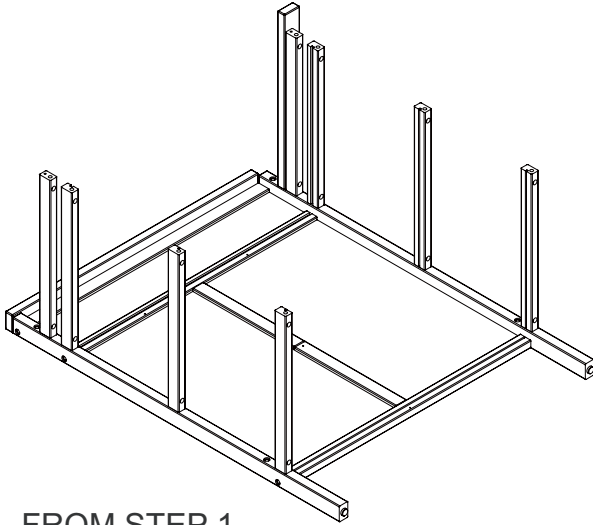

FROM STEP 1

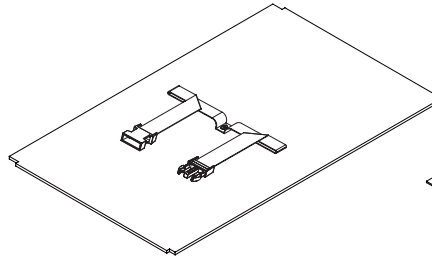

G. CHANGER TOP SHELF x 1
PART # 21340

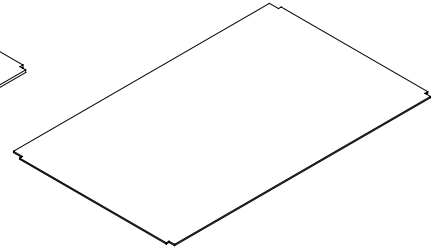

H. CHANGER LOWER SHELVES x 2
PART # 21341

LAY CHANGER LEFT SIDE (PART A) ON IT'S SIDE AND RAILS UP, SLIDE CHANGER TOP SHELF (PART G) IN CHANGER WIDE GROOVED RAILS (PART E) GROOVES AS SHOWN (**BE SURE THE RESTRAINT STRAP IS ON TOP**).
SLIDE LOWER SHELVES (PART H) INTO CHANGER GROOVED RAILS (PART F) GROOVES AS SHOWN.

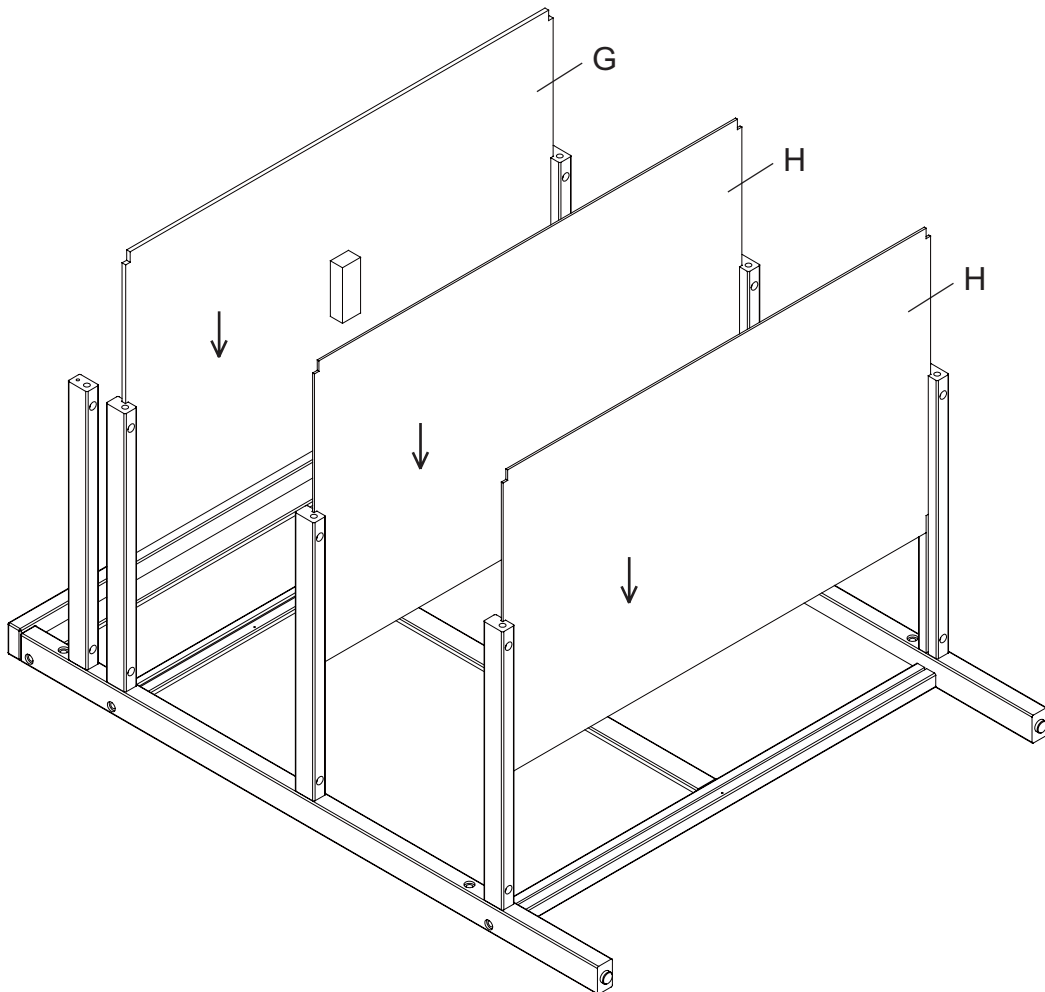

SECTION 1: CHANGING TABLE ASSEMBLY

STEP 3

PARTS AND TOOLS REQUIRED TO COMPLETE STEP

B. CHANGER RIGHT
SIDE x 1
PART # 21335

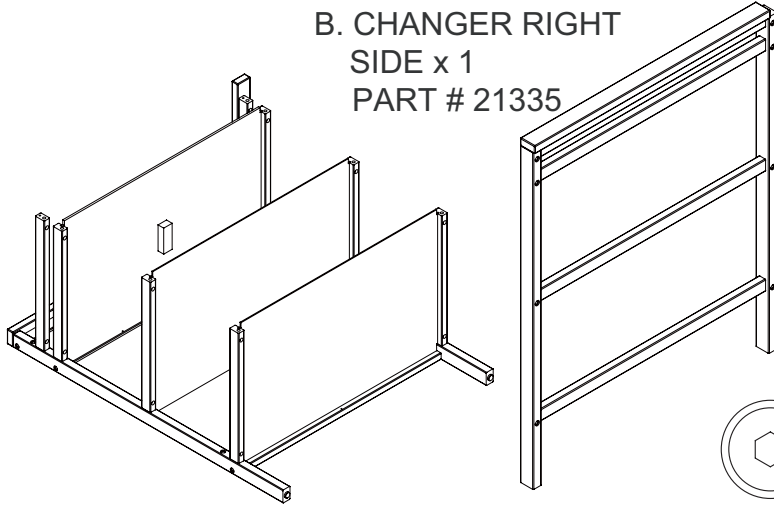

FLAT HEAD SCREWDRIVER
(NOT SUPPLIED)

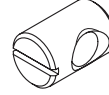

U. BARREL NUT x 8

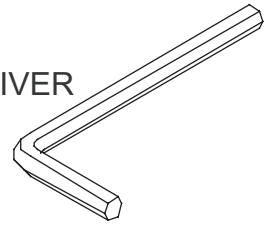

M4 ALLEN WRENCH
SUPPLIED

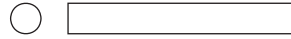

V. $\Phi 4 \times 30$ mm METAL PIN x 2

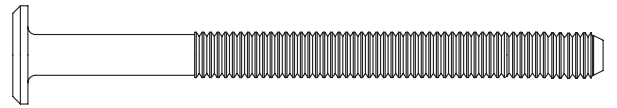
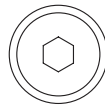

R. M6x76 mm BOLT x 8

ATTACH (1) CHANGER RIGHT SIDE (PART B) TO THE ASSEMBLY FROM STEP 2 USING (2) $\Phi 4 \times 30$ mm METAL PINS (PART V), (8) M6x76mm BOLTS (PART R) AND (8) BARREL NUTS (PART U). TIGHTEN WITH THE M4 ALLEN WRENCH. USE THE FLAT HEAD SCREWDRIVER TO HOLD THE BARREL NUT IN THE PROPER ALIGNMENT.

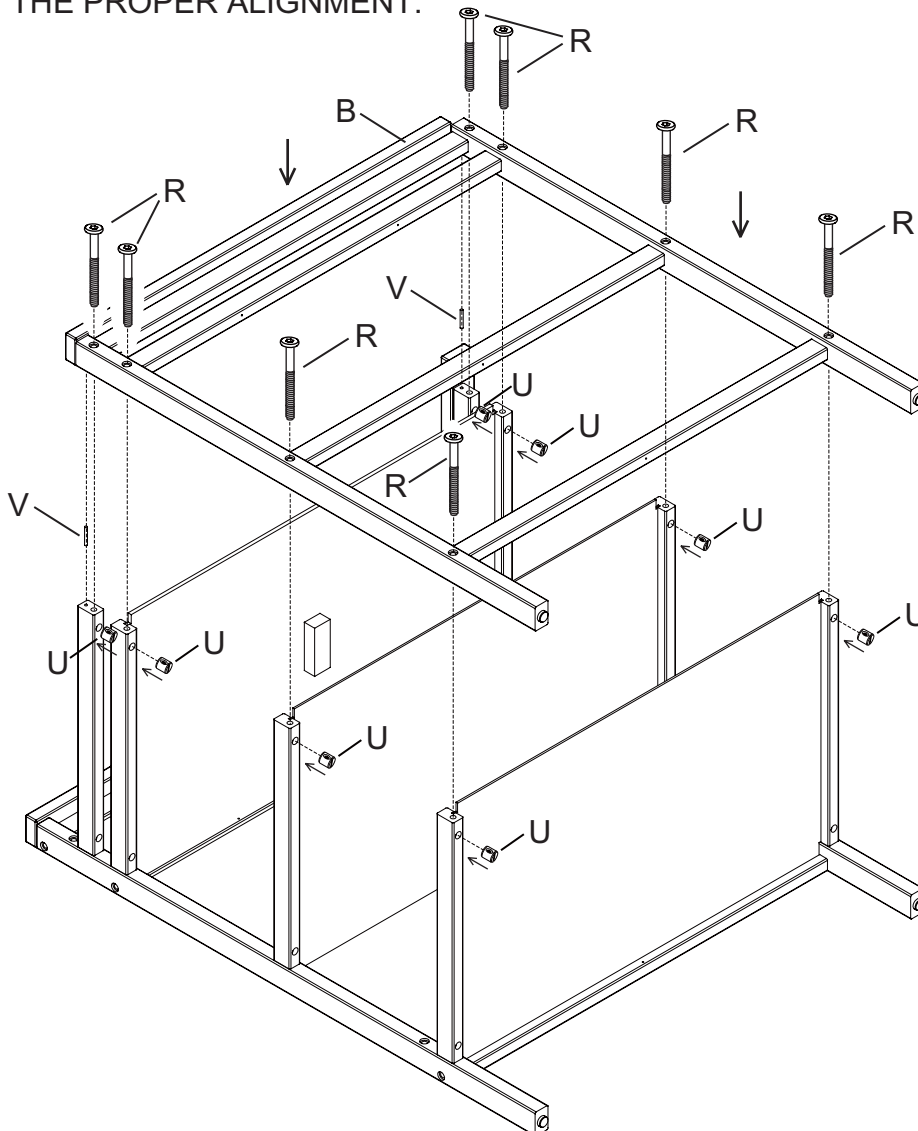

SECTION 1: CHANGING TABLE ASSEMBLY

STEP 4

PARTS AND TOOLS REQUIRED TO COMPLETE STEP

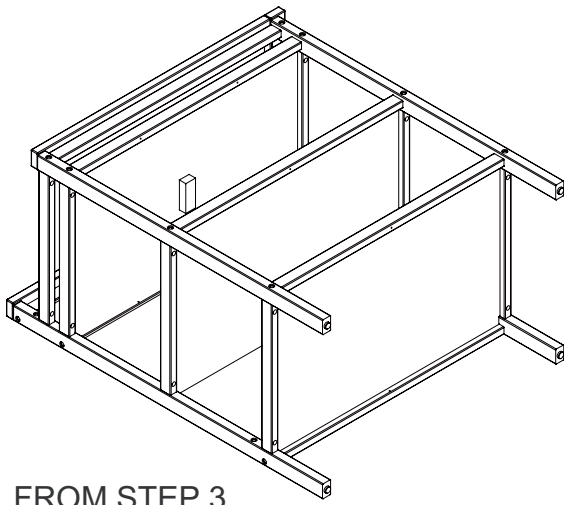

W. M4 x12 mm WOOD SCREW x 8

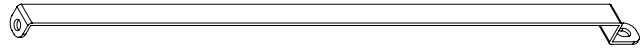

X. SHELF BRACE x 4

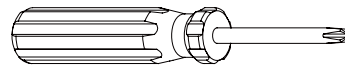

PHILLIPS SCREWDRIVER
(NOT SUPPLIED)

ATTACH (4) SHELF BRACES (PART B) TO THE ASSEMBLY FROM STEP 3 USING (8) M4x12mm WOOD SCREWS (PART W). TIGHTEN WITH THE PHILLIPS SCREWDRIVER.

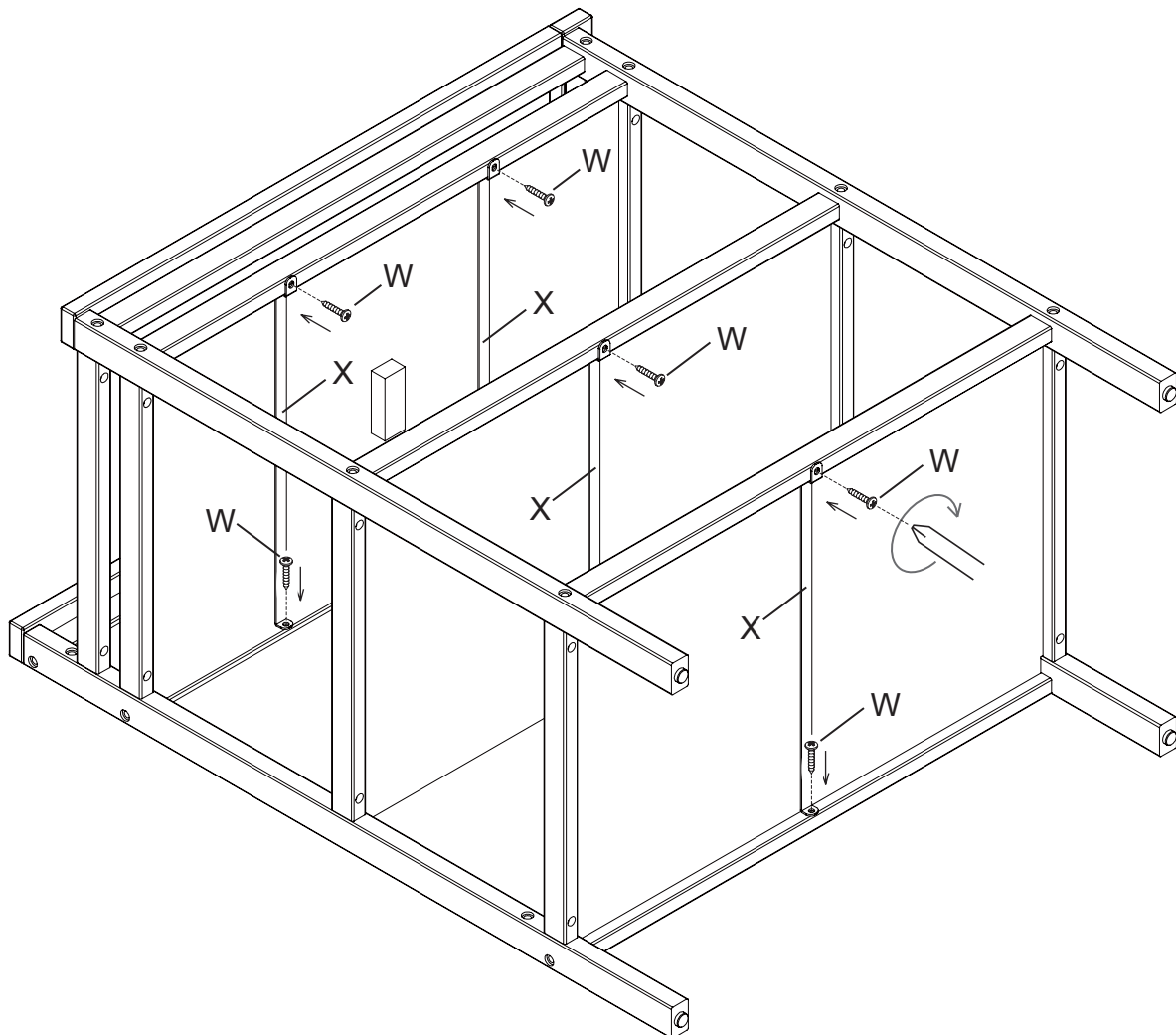

SECTION 2: CRIB ASSEMBLY

STEP 1

PARTS AND TOOLS REQUIRED TO COMPLETE STEP

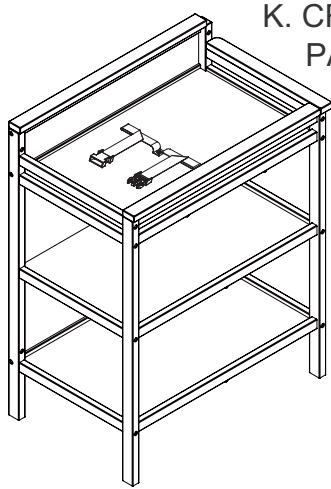

K. CRIB END x 1
PART # 21343

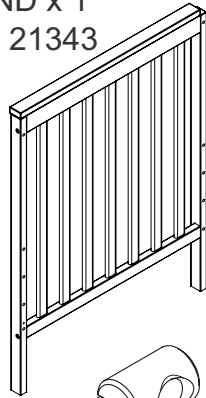

L. CRIB BACK SIDE x 1
PART # 21346

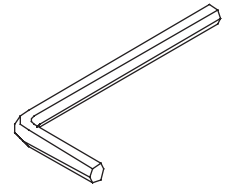
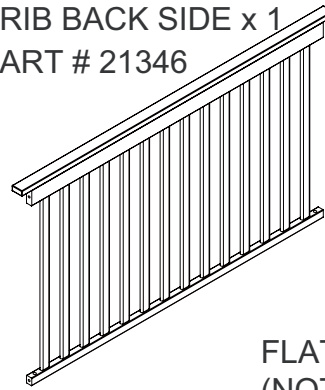

M4 ALLEN WRENCH
SUPPLIED

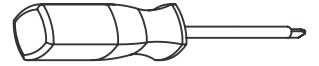

FLAT HEAD SCREWDRIVER
(NOT SUPPLIED)

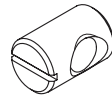

U. BARREL NUT x 4

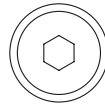

R. M6x76 mm BOLT x 4

FROM SECTION 1 STEP 4

ATTACH (1) CRIB BACK SIDE (PART L) AND (1) CRIB END (PART K) TO THE ASSEMBLY FROM SECTION 1 STEP 4 USING (4) M6x76mm BOLTS (PART R) AND (4) BARREL NUTS (PART U). TIGHTEN WITH THE M4 ALLEN WRENCH. USE THE FLAT HEAD SCREWDRIVER TO HOLD THE BARREL NUT IN THE PROPER ALIGNMENT.

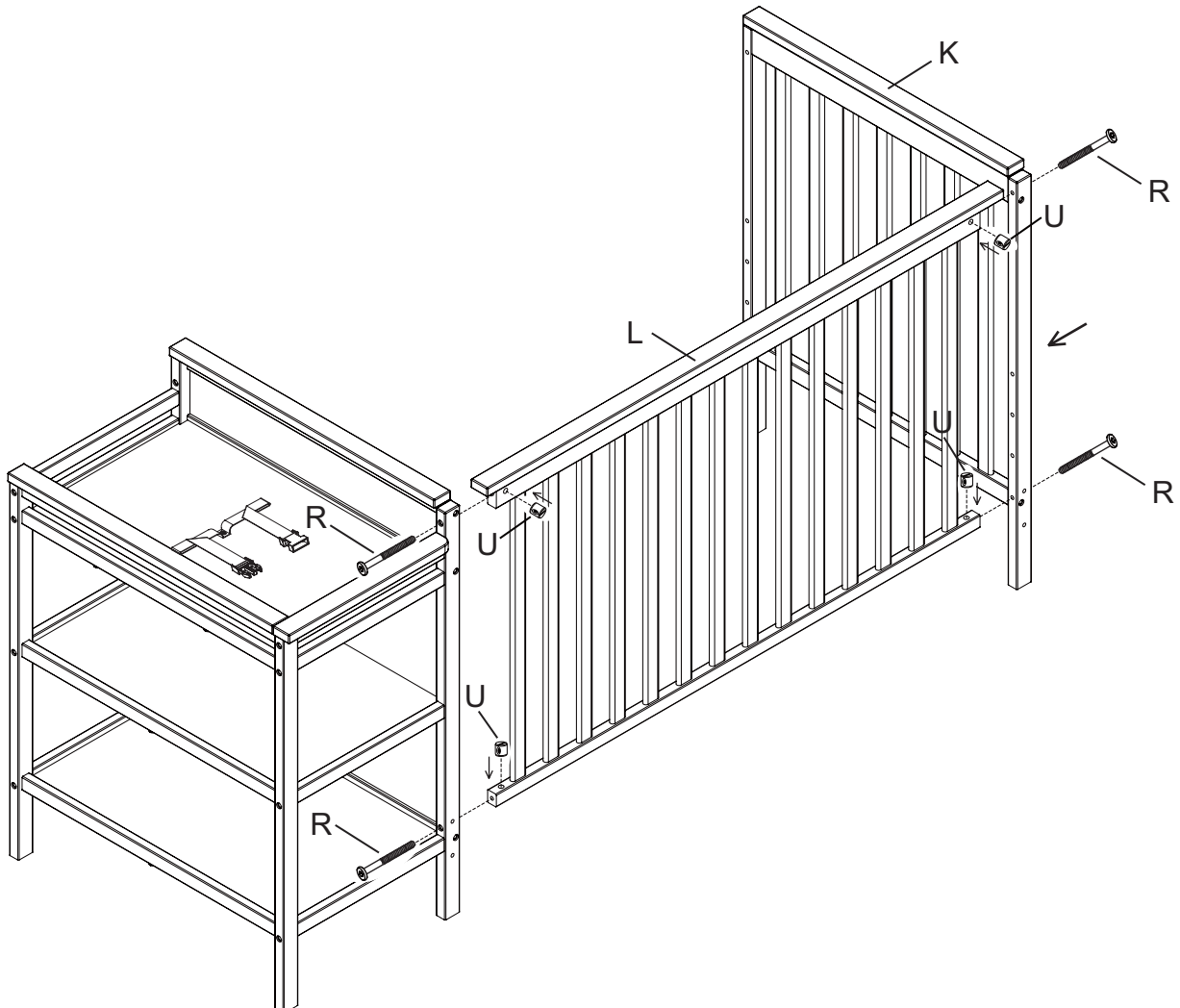

SECTION 2: CRIB ASSEMBLY

STEP 2

PARTS AND TOOLS REQUIRED TO COMPLETE STEP

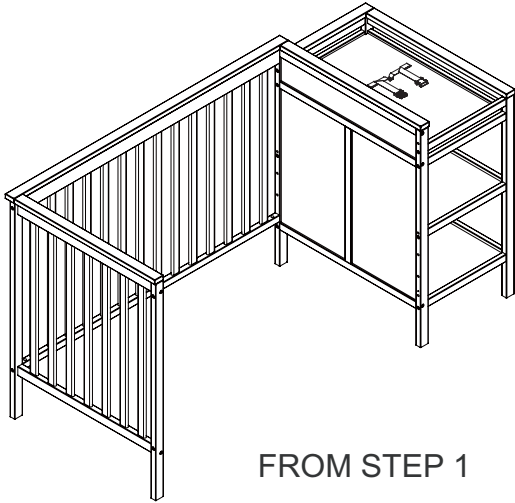

FROM STEP 1

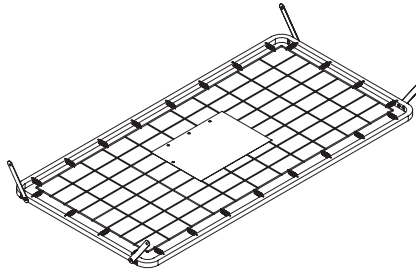

P. MATTRESS SUPPORT x 1
PART # 16945

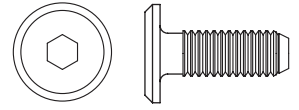

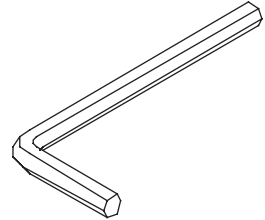

T. M6x17 mm BOLT x 4

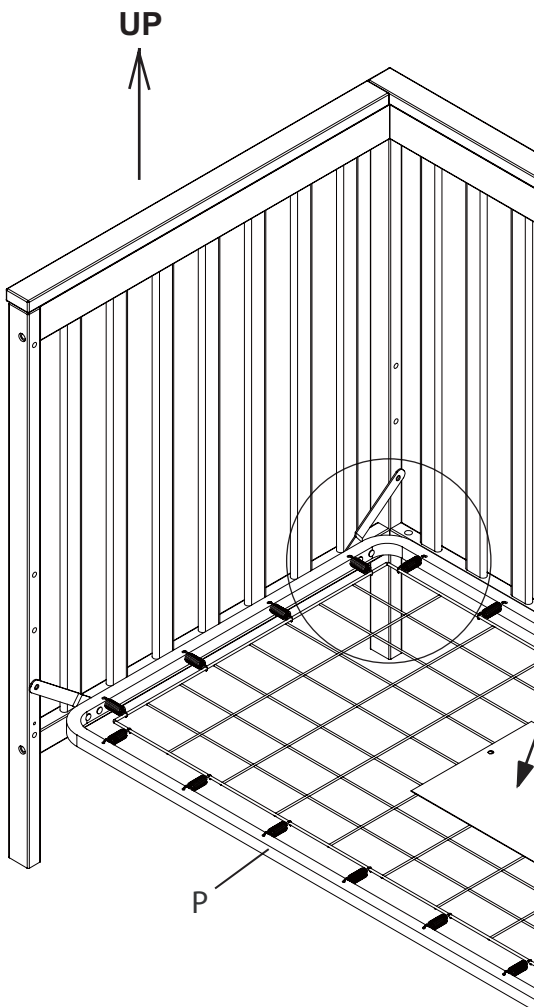

M4 ALLEN WRENCH
SUPPLIED

ATTACH THE MATTRESS SUPPORT (PART P) IN ALL CORNERS USING (1) M6x17 mm BOLT (PART T) IN EACH CORNER. TIGHTEN WITH THE M4 ALLEN WRENCH.



THE  WARNINGS PRINTED ON THE POUCH ATTACHED TO THE MATTRESS SUPPORT MUST FACE UP, THE SPRINGS MUST FACE UP.

THIS CRIB HAS (3) ADJUSTMENT POSITIONS, USE THE HIGHEST ONLY FOR NEW BORN, MOVE THE MATTRESS DOWN AS THE CHILD GROWS.

WARNING:

FALL HAZARD: WHEN CHILD IS ABLE TO PULL TO A STANDING POSITION, SET MATTRESS TO LOWEST POSITION AND REMOVE BUMPER PADS, LARGE TOYS AND OTHER OBJECTS THAT COULD SERVE AS STEPS FOR CLIMBING OUT.

 **WARNINGS ON POUCH MUST FACE UP.**

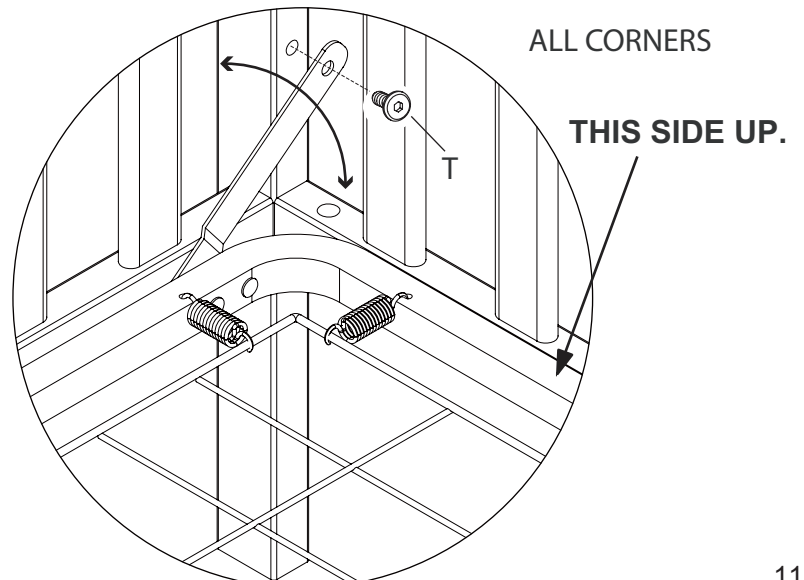

SECTION 2: CRIB ASSEMBLY

STEP 3

PARTS AND TOOLS REQUIRED TO COMPLETE STEP

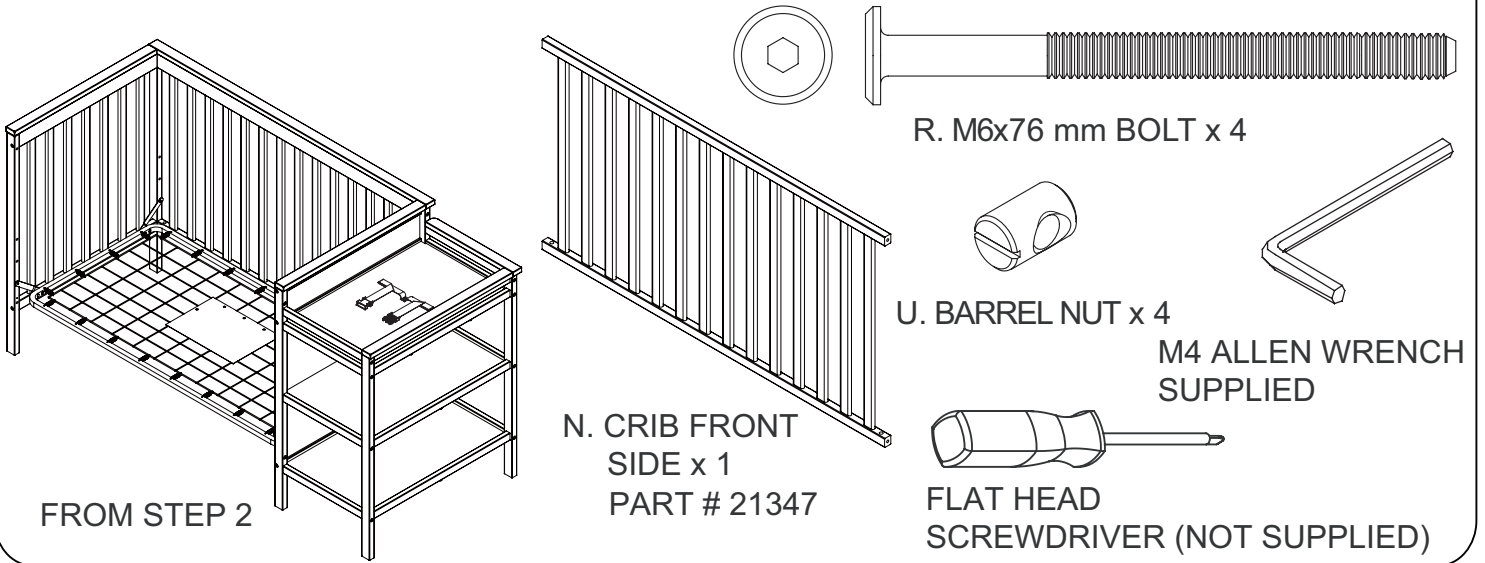

ATTACH (1) CRIB FRONT SIDE (PART N) TO THE ASSEMBLY FROM STEP 2 USING (4) M6x76mm BOLTS AND (4) BARREL NUTS (PART U). TIGHTEN WITH THE M4 ALLEN WRENCH. HOLD THE BARREL NUT IN PROPER ALIGNMENT USING THE SCREWDRIVER.

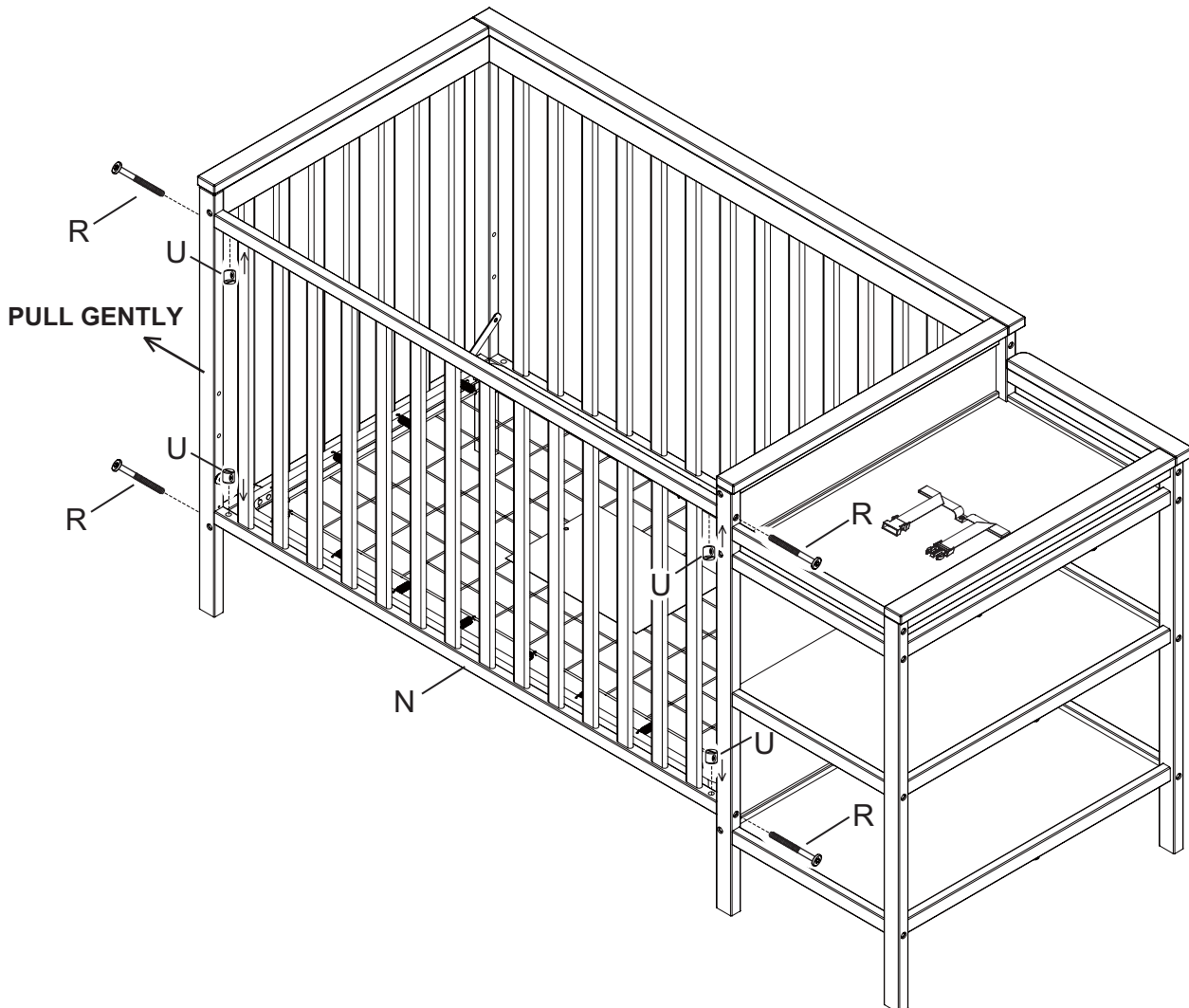

SECTION 3: STEP 1 CHANGING PAD ATTACHMENT AND USE

PARTS AND TOOLS REQUIRED TO COMPLETE STEP

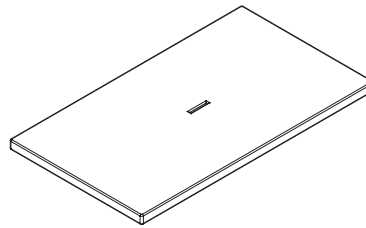
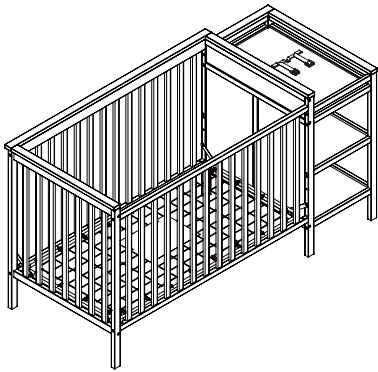

J. CHANGER PAD x 1
PART # 21342

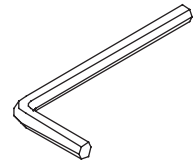

M4 ALLEN WRENCH
SUPPLIED

1. CHECK THAT THE BOLT SECURING THE STRAP IS TIGHT USING M4 ALLEN WRENCH.
2. INSERT THE STRAP THROUGH THE HOLE IN THE CHANGER PAD (PART J).
3. PLACE PAD ON CHANGING SURFACE.

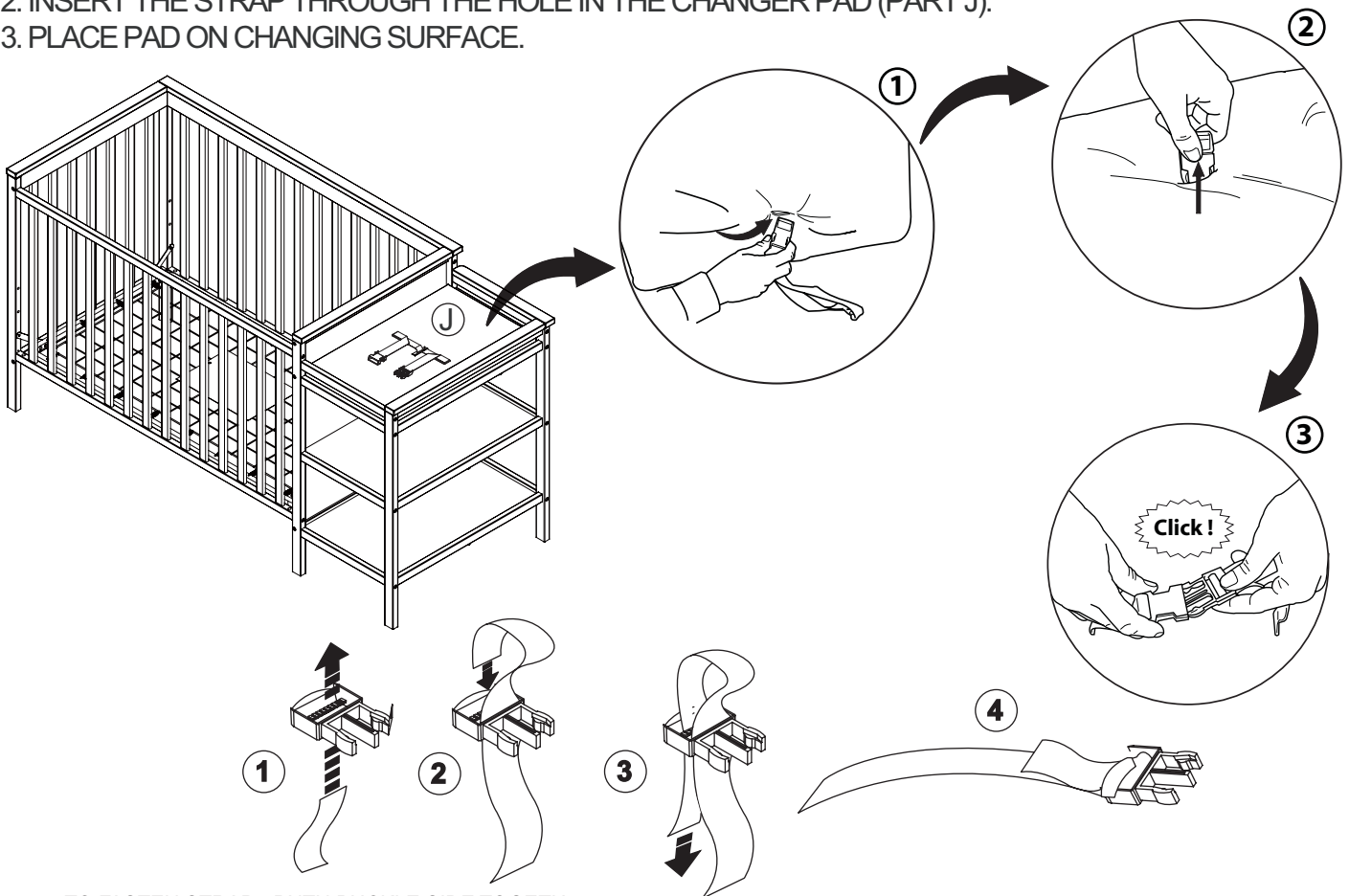

TO FASTEN STRAP - PUTH BUCKLE SIDE TOGETH-
ERBESURE BUCKLE IS FULLY FASTENED TO
SECURE CHILD SAFFELY

TO RELEASE PRESS BOTH TABS AND PULL APART

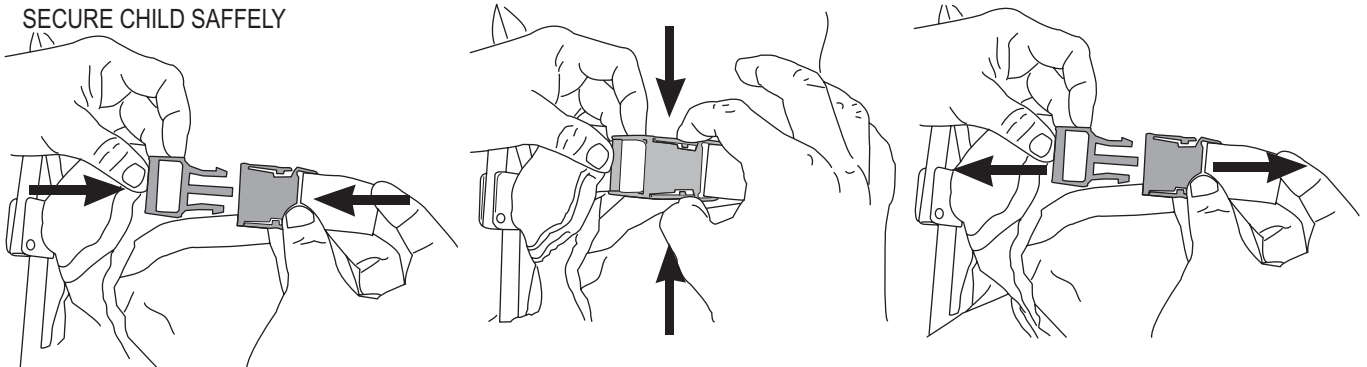

SECTION 3: STEP 2 STORING INSTRUCTION BOOKLET

PARTS AND TOOLS REQUIRED TO COMPLETE STEP



ASSEMBLY INSTRUCTION
BOOKLET

STORE THE ASSEMBLY INSTRUCTION BOOKLET IN THE POUCH ATTACHED TO THE MATTRESS SUPPORT. STORE ALL PARTS AND TOOLS SEPARATELY, IN A SAFE PLACE.

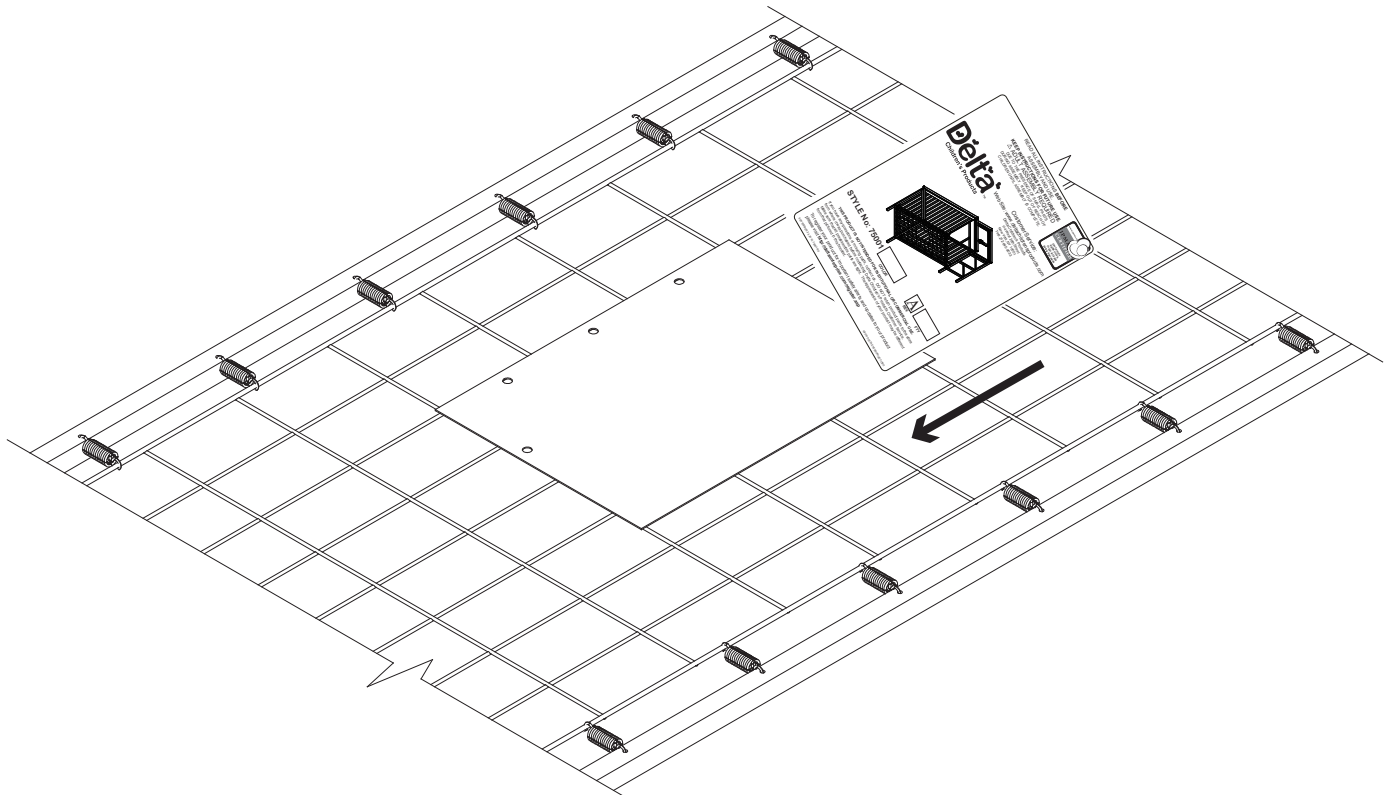

SECTION 4: TODDLER BED CONVERSION

STEP 1

PARTS AND TOOLS REQUIRED TO COMPLETE STEP

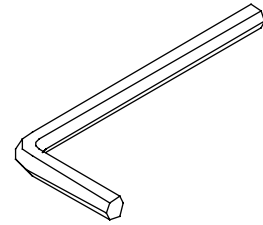
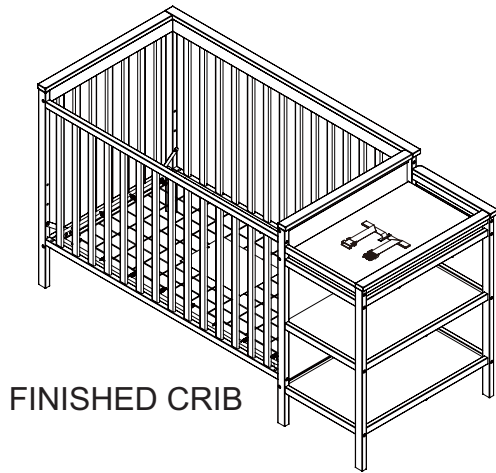

M4 ALLEN WRENCH
SUPPLIED

REMOVE THE CRIB FRONT SIDE INSTALLED IN STEP 3 OF SECTION 2 CRIB ASSEMBLY.

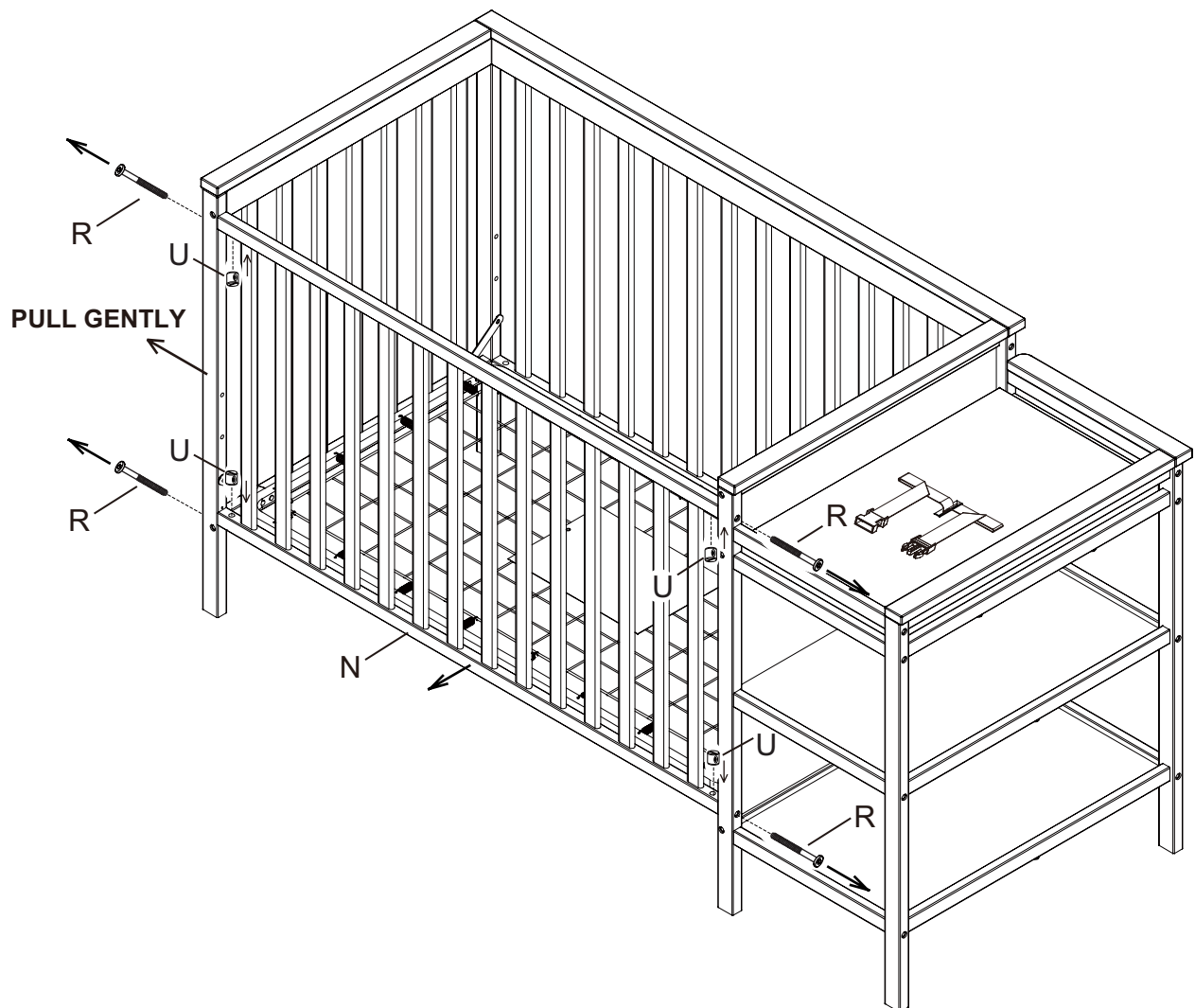

SECTION 4: TODDLER BED CONVERSION

STEP 2

PARTS AND TOOLS REQUIRED TO COMPLETE STEP

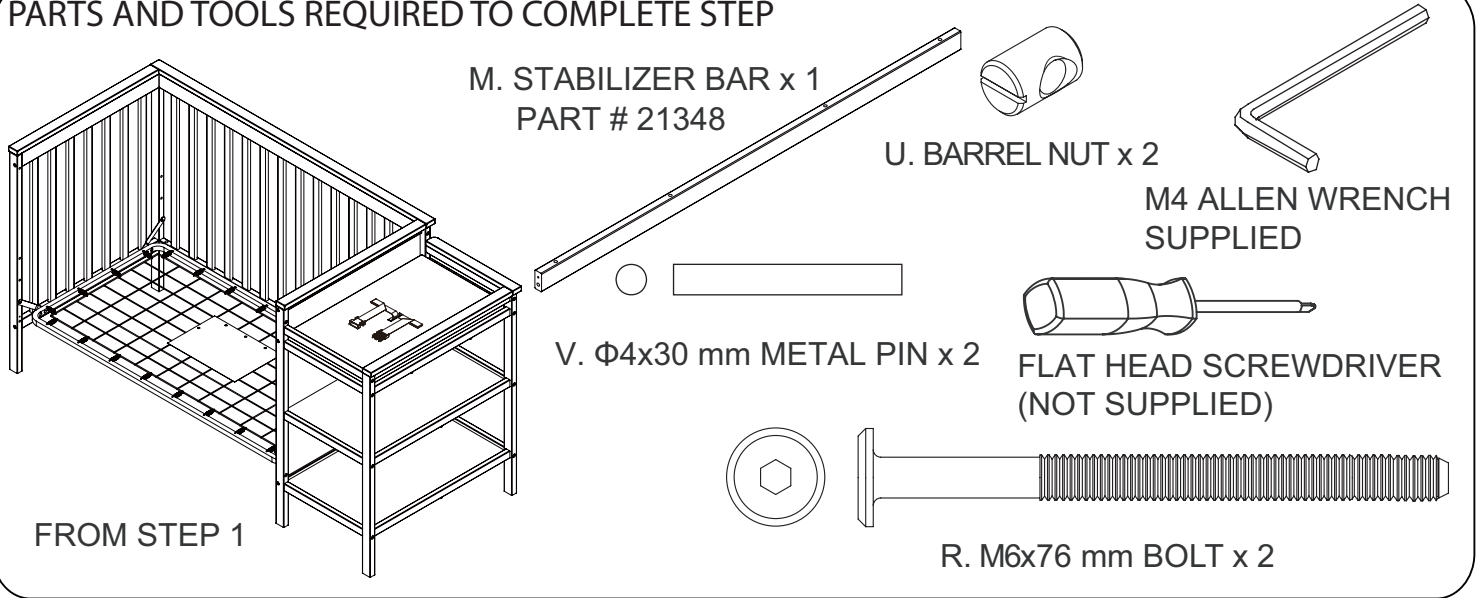

ATTACH THE STABILIZER BAR (PART M) TO THE ASSEMBLY FROM STEP 1 USING (2) $\Phi 4 \times 30$ mm METAL PINS (PART V), (2) M6x76 mm BOLTS (PART R) AND (2) BARREL NUTS (PART U). TIGHTEN WITH THE M4 ALLEN WRENCH. USE THE FLAT HEAD SCREWDRIVER TO HOLD THE BARREL NUT IN THE PROPER ALIGNMENT.

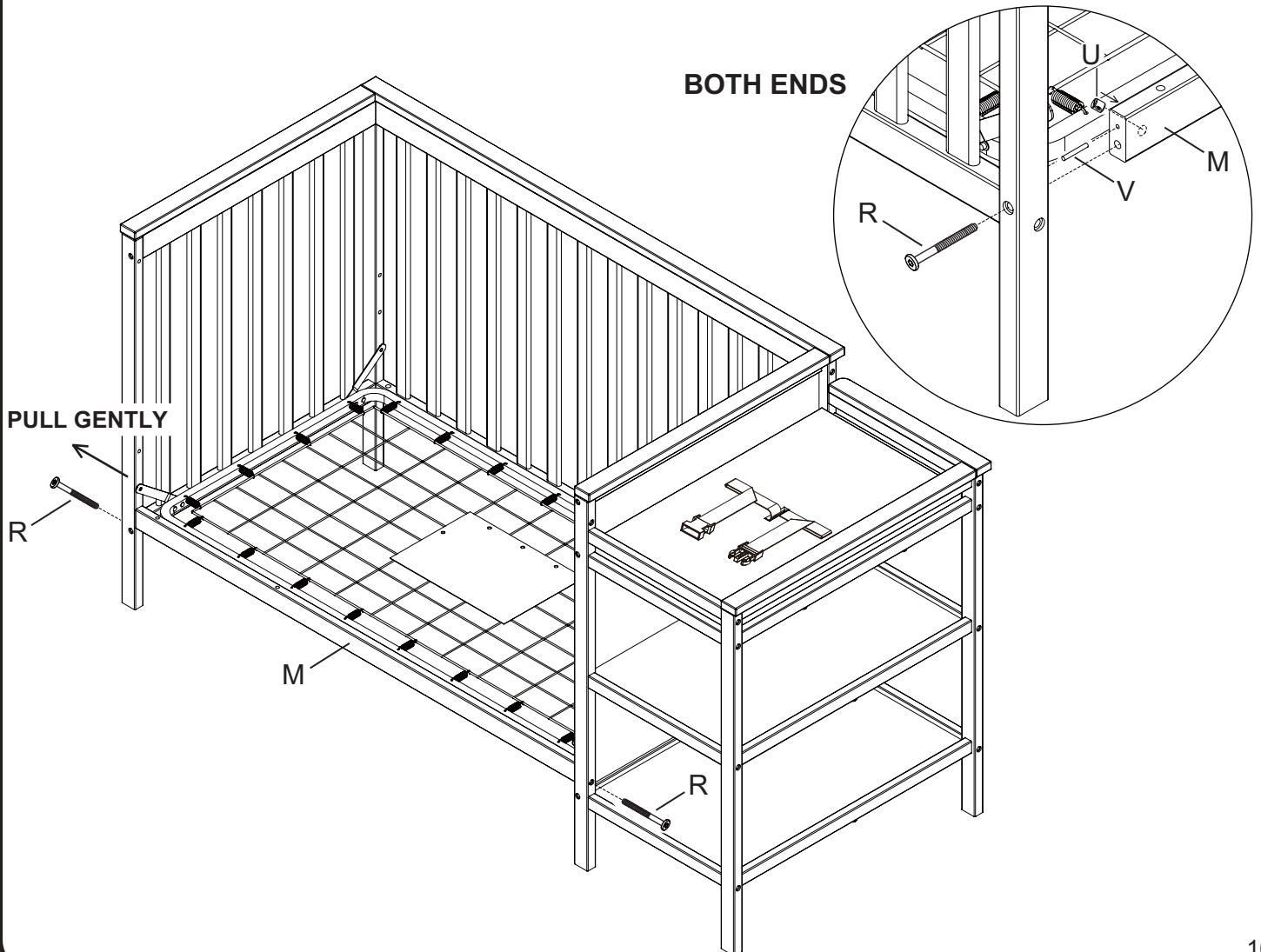

SECTION 4: TODDLER BED CONVERSION STEP 3

⚠ WARNING: SEE PAGE 3 FOR TODDLER BED WARNINGS

THE MATTRESS SUPPORT MUST BE IN THE LOWEST POSITION.
STORE ALL HARDWARE SAFELY.
READ ALL WARNINGS ON PAGE 3

AS SHOWN, USE AS A DAY BED OR LOVE SEAT SOFA.
DO NOT USE WITHOUT STABILIZER BAR INSTALLED.

⚠ STABILIZER BAR MUST BE USED
WHEN CONVERTED TO A TODDLER BED.

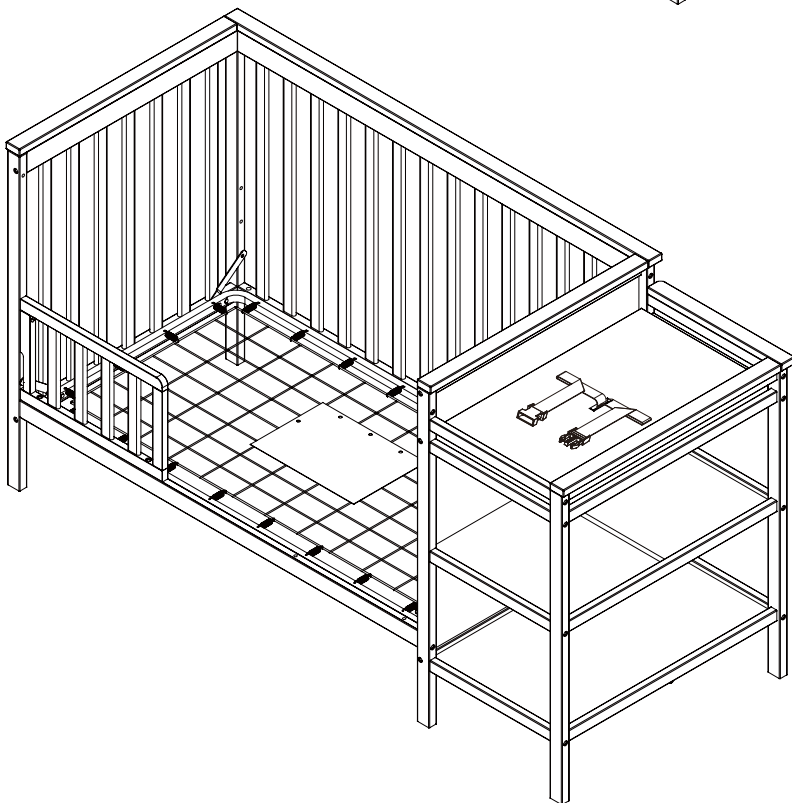
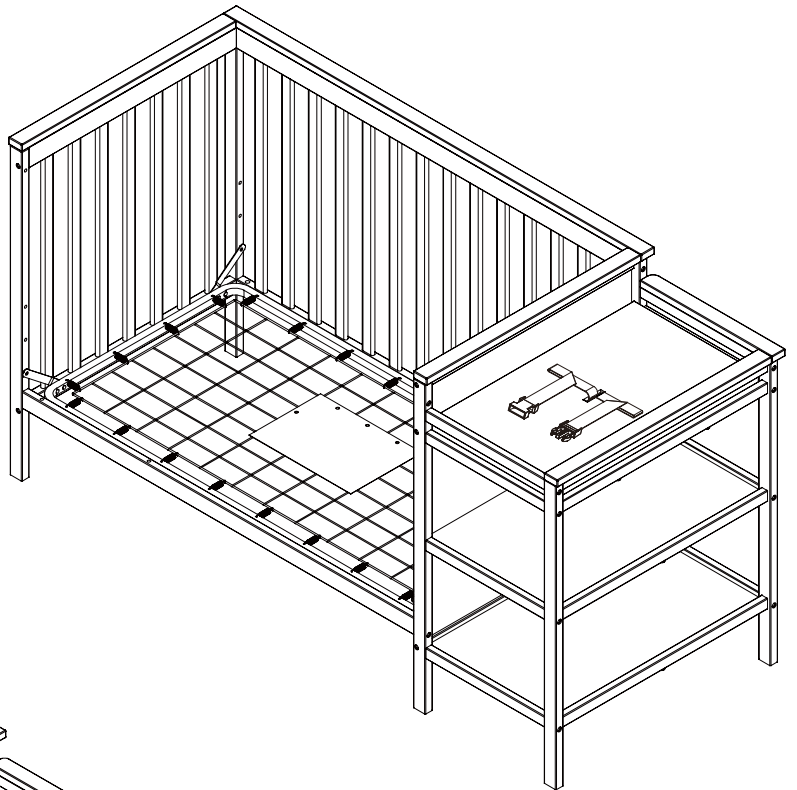

A TODDLER BED GUARDRAIL IS
AVAILABLE FOR THIS CRIB.
PLEASE SEE YOUR CRIB RETAILER, VISIT
WWW.DELTACHILDRENSPRODUCTS.COM
OR CONTACT DELTA CONSUMER CARE
FOR MORE INFORMATION.
THIS CRIB USES DELTA STYLE # 0081
GUARDRAIL.

SECTION 5: FULL SIZE BED CONVERSION

STEP 1

PARTS AND TOOLS REQUIRED TO COMPLETE STEP

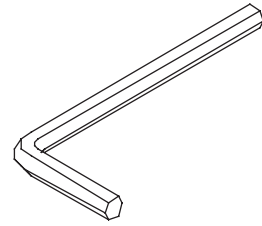

M4 ALLEN WRENCH
SUPPLIED

REMOVE THE POST FROM THE LEFT CHANGER SIDE (PART A) BY REMOVING THE BOLTS. STORE ALL PARTS CAREFULLY FOR FUTURE USE, SEE PAGE 3 FOR INFORMATION.

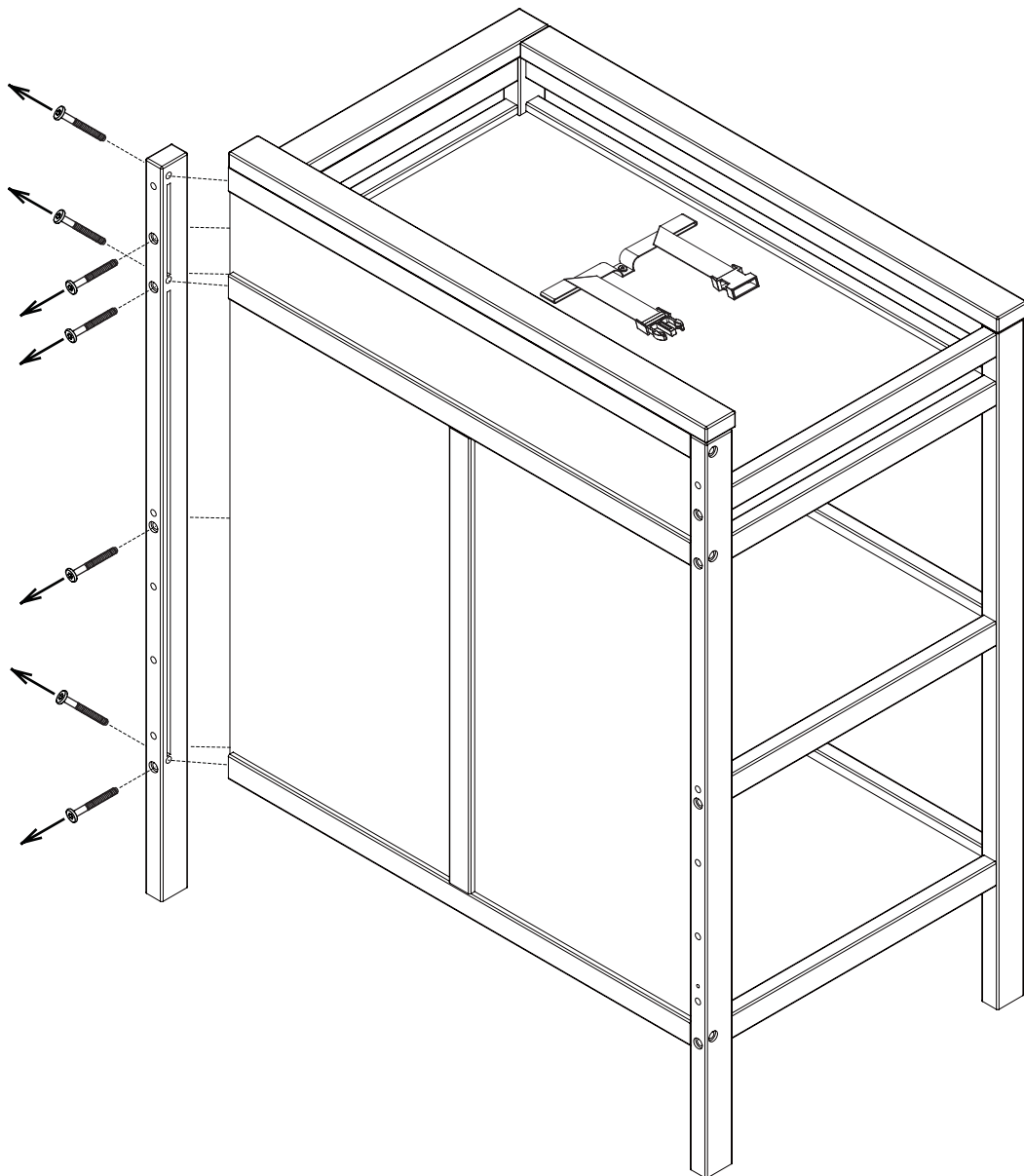

SECTION 5: FULL SIZE BED CONVERSION

STEP 2

PARTS AND TOOLS REQUIRED TO COMPLETE STEP

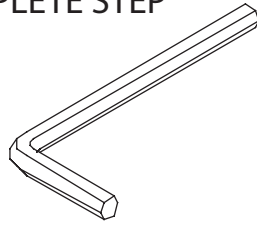

M4 ALLEN WRENCH
SUPPLIED

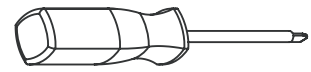

FLAT HEAD SCREWDRIVER
(NOT SUPPLIED)

DISASSEMBLE THE CRIB END BY REMOVING THE PREASSEMBLED BOLTS WITH THE M4 ALLEN WRENCH. ATTACH THE POST REMOVED FROM THE CHANGER IN THE PREVIOUS STEP TO THE END OF THE CRIB BACK SIDE WHERE IT WAS PREVIOUSLY ATTACHED USING (2) M6x76mm (PART R) AND (2) BARREL NUTS (PART U). TIGHTEN BOLTS WITH THE M4 ALLEN WRENCH. STORE ALL PARTS AND HARDWARE IN A SAFE PLACE. SEE PAGE 3 FOR INFORMATION.

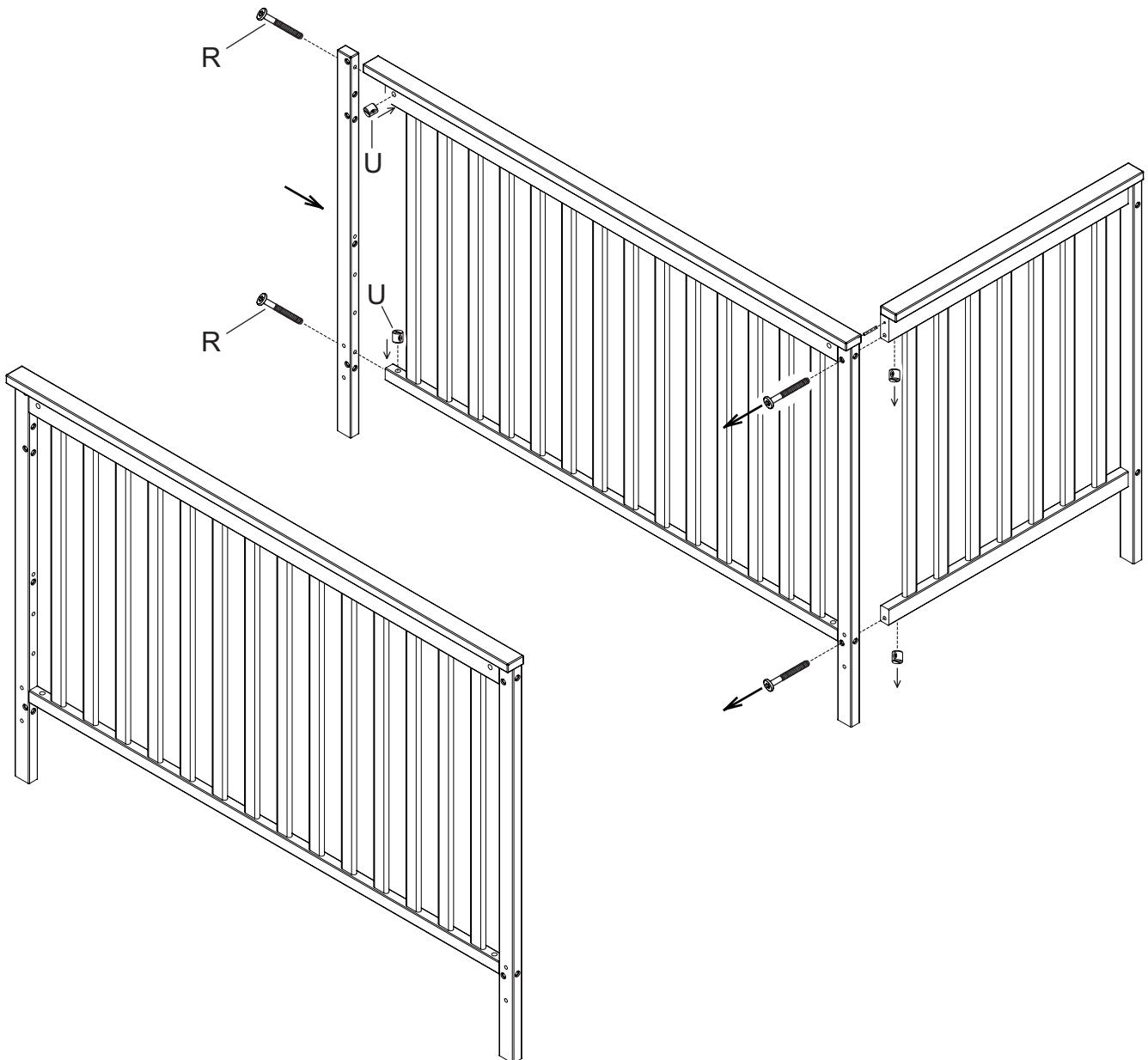

SECTION 5: FULL SIZE BED CONVERSION

STEP 3

PARTS AND TOOLS REQUIRED TO COMPLETE STEP

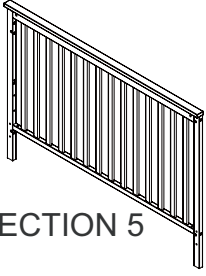

FROM SECTION 5
STEP 2

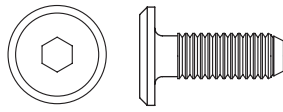

T. M6x17 mm BOLT x 4

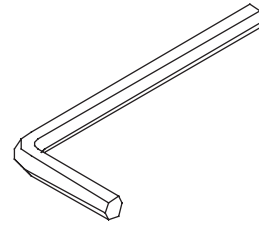

M4 ALLEN WRENCH
SUPPLIED

ATTACH BED FRAME TO THE HEADBOARD (FROM SECTION 5 STEP 2) USING (4) M6x17mm BOLTS (PART T). FOLLOW ALL INSTRUCTIONS SUPPLIED WITH THE BEDFRAME.

NOTE: BED FRAME SYSTEM IS NOT INCLUDED, SEE YOUR FURNITURE OR MATTRESS RETAILER. CONTACT DELTA CHILDREN'S PRODUCTS FOR INFORMATION OR WITH QUESTIONS.

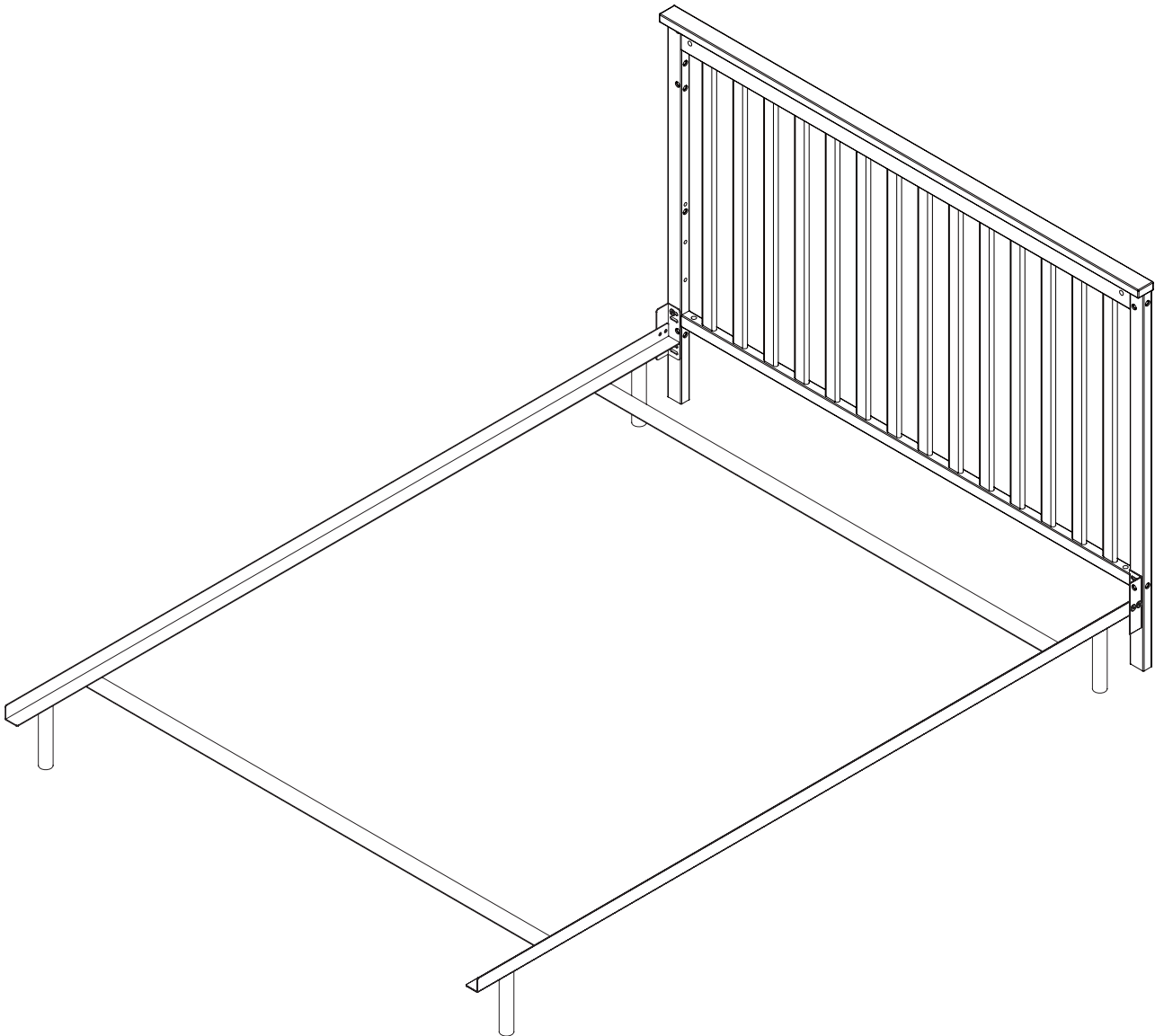



Children's Products

Customer Service:

Web Site: www.deltachildrensproducts.com

Delta Children's Products

114 West 26th Street

New York, NY 10001

Tele.212-645-9033

Warranty: This Delta Crib is warranted to be free from defects for a period of 1 year from the date of purchase under normal use. This warranty extends only to the original retail purchaser and is valid only when supplied with proof of purchase, or if received as a gift, when the registration is on file with Delta.

To register your product for important safety alerts and updates to your product please visit <http://deltaenterprise.com/register.asp>

Please do not return this item to the store before contacting us about missing parts or with any questions.

To report a problem, please log on to www.deltachildrensproducts.com and click the Customer Service Tab, log on to www.deltaenterprise.com/customer_service.asp, or contact us by phone at (212) 645-9033.

In the event that you need to contact our customer service department please have the Style Number and Lot Number available. Use the space below to make note of those numbers. They can be found on the label on the Crib End bottom rail.

Style No.: _____

Lot No. : _____

Pack Date: _____

Date of Purchase: _____ (you should also keep your receipt)