

Delta™

Children's Products

READ ALL INSTRUCTIONS BEFORE
ASSEMBLY AND USE.

KEEP INSTRUCTIONS FOR FUTURE USE.

⚠ ADULT ASSEMBLY REQUIRED

DUE TO THE PRESENCE OF SMALL PARTS
DURING ASSEMBLY, KEEP OUT OF REACH OF
CHILDREN UNTIL ASSEMBLY IS COMPLETE.

SPRINGTIME 6 DRAWER DRESSER

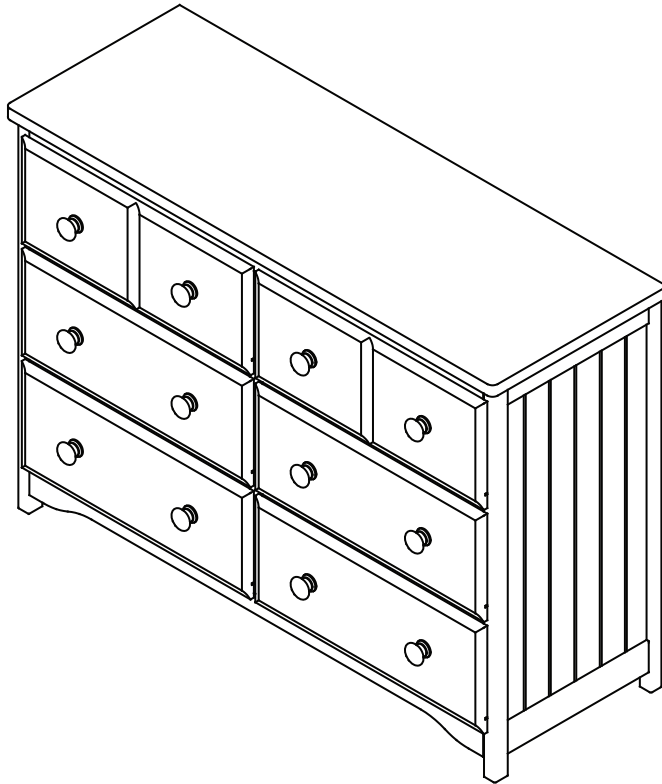

THIS PRODUCT IS NOT INTENDED FOR INSTITUTIONAL OR COMMERCIAL USE.

STYLE No: 74106-



COLOR



REV



FACTORY

When contacting Delta Consumer Care you
will need to reference the above number.

Consumer Care:

www.deltachildrensproducts.com

Delta Children's Products
114 West 26th Street
New York, NY 10001
Tele.212-645-9033

To register your product for important safety alerts and updates to your product
please visit www.deltachildrensproducts.com and click on Product Registration.

⚠WARNING:

Serious or fatal crushing injuries can occur from furniture tip-over. To help prevent tip-over:

- Place heaviest items in the lowest drawers.
- Unless specifically designed to accommodate, **do not** set TV's or other heavy objects on the top of this product.
- Never** allow children to climb or hang on drawers, doors, or shelves.
- Never** open more than one drawer at a time.

Use of tip-over restraints may only reduce, but not eliminate, the risk of tip-over.

- Always monitor your child's activity when in the nursery.
- Do not** allow standing in drawers.
- Do not** allow standing on top of this product.
- Accessory Items must be securely fastened to this product according to the instructions provided with those items.
- To avoid head injury, do not allow children to play underneath open drawers.
- Do not leave drawers open when not in use.

NOTES ON ASSEMBLY:

- During the assembly process whenever using screws or bolts, check each by placing the screw/bolt on the diagram of the item which is drawn actual size and design. Be sure to use the proper size and shape specified in the instructions.
- To assemble this unit you may be required to place the unit on it's side and face. It is strongly recommended that assembly is done on a soft, non-abrasive surface to avoid damaging the finish.

NOTES ON CARE AND MAINTENANCE:

- **Do not** scratch or chip the finish.
- Inspect the product periodically, contact delta children's products for replacement parts or questions.
- **Do not** store the product or any parts in extreme temperatures and conditions such as a hot attic or a damp, cold basement. These extremes can cause a loss of structural integrity.
- To preserve the luster of the high quality finish on your product, it is recommended to place a doily or felt pad under any items you place on the finish.
- Clean with a damp cloth, then a dry cloth to preserve the original luster and beauty of this fine finish.
- Do not** use abrasive chemicals.
- Do not** spray cleaners directly onto furniture.
- Lift slightly when moving on carpeting to prevent leg breakage.
- Use of a vaporizer near furniture will cause wood to swell and finish to peel.

PARTS: HARDWARE KITS PART #21413

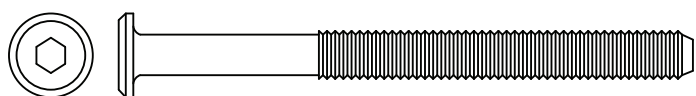

A. 75mm BOLT x1

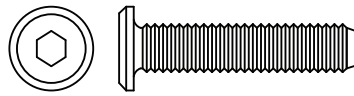

B. 30mm BOLT x4



C. CRESCENT WASHER x8

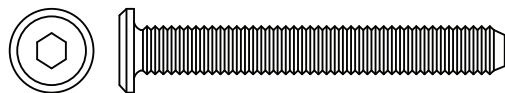

D. 50mm BOLT x19

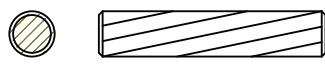

E. WOOD DOWEL x44

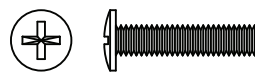

F. KNOB SCREW x12

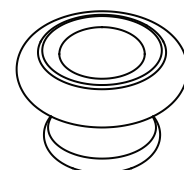

K. KNOB x12
PART# 21377

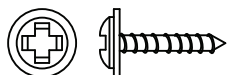

G. SCREW x28

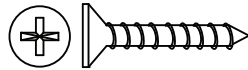

H. DRAWER SCREW x54

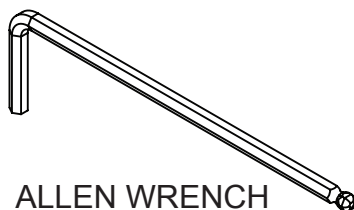

ALLEN WRENCH

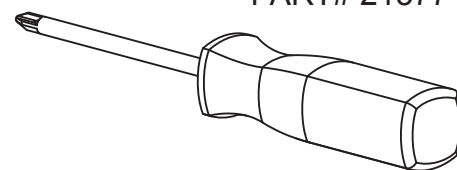

PHILLIPS SCREWDRIVER
NOT INCLUDED

PARTS: MAKE SURE THAT ALL PRE-ASSEMBLED PARTS ARE TIGHT.

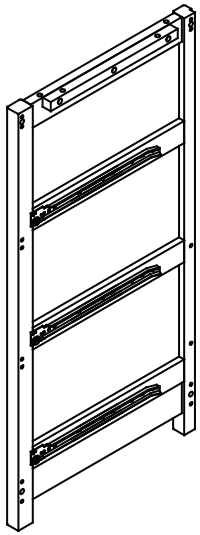

L. Left side
Part# 21398

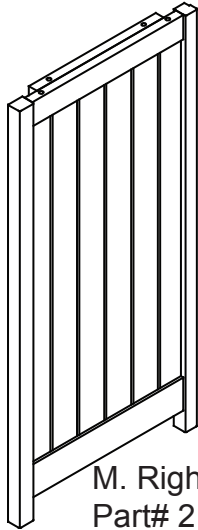

M. Right side
Part# 21399

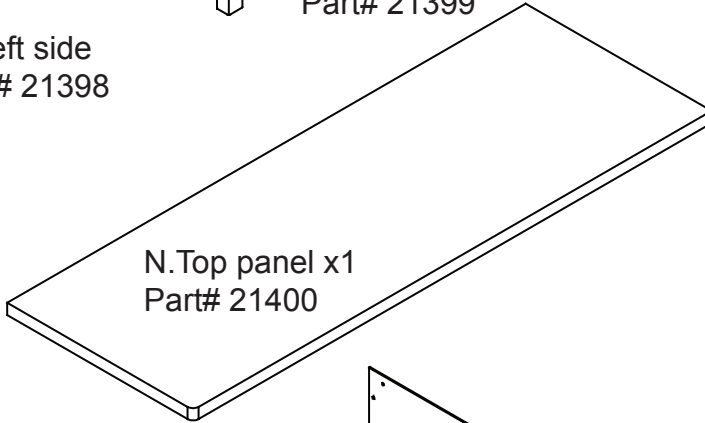

N. Top panel x1
Part# 21400

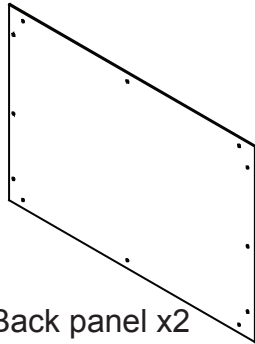

W. Back panel x2
Part# 21407

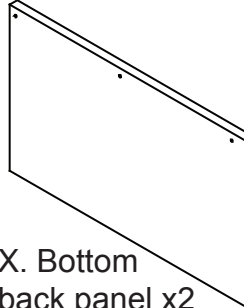

X. Bottom
back panel x2
Part# 21916

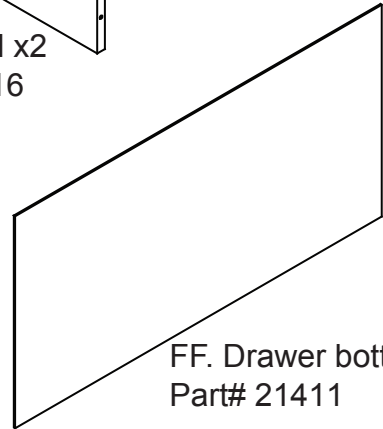

FF. Drawer bottom x6
Part# 21411

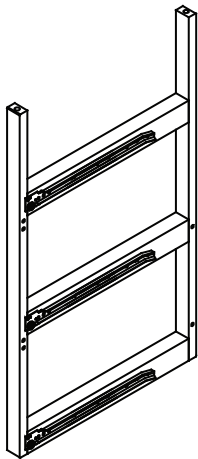

V. Divider frame x1
Part# 21406

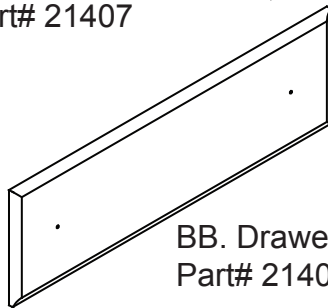

BB. Drawer front x4
Part# 21409

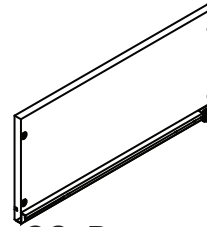

CC. Drawer right
side x6
Part# 21391

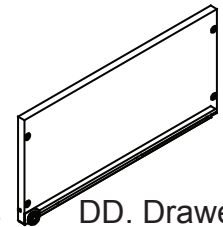

DD. Drawer left
side x6
Part# 21392

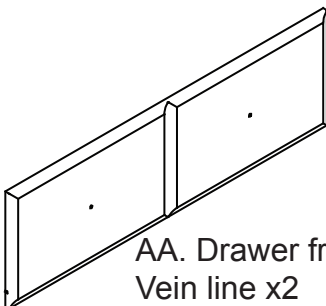

AA. Drawer front
Vein line x2
Part# 21408

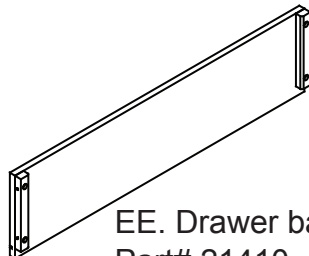

EE. Drawer back x6
Part# 21410

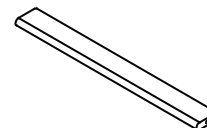

GG. Drawer
support x6
Part# 21394

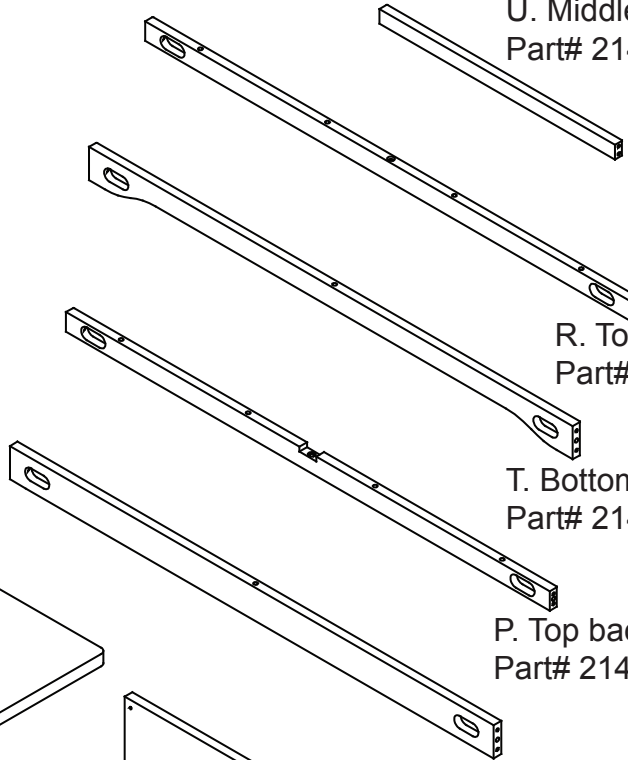

U. Middle front rail x4
Part# 21405

R. Top front rail x1
Part# 21402

T. Bottom front rail x1
Part# 21404

P. Top back rail x1
Part# 21401

S. Bottom back rail x1
Part# 21403

HARDWARE SYSTEM - REVIEW BEFORE ASSEMBLY

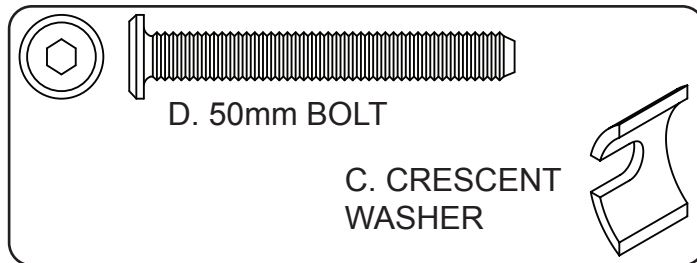
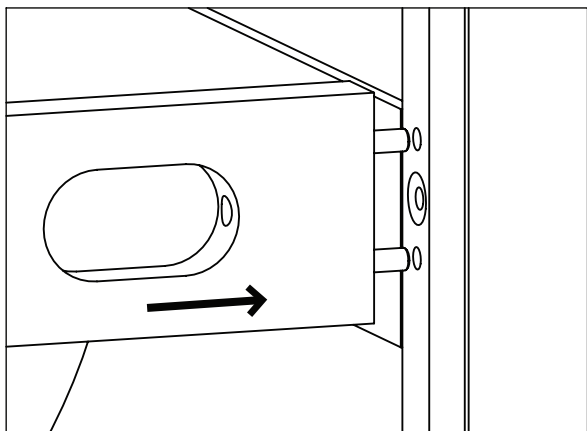

INSERT THE DOWELS IN THE RAIL INTO THE HOLES IN THE E POST.

INSERT THE BOLT INTO THE SLOT. TURN CLOCKWISE WITH FINGERS OR THE ALLEN WRENCH PROVIDED. **DO NOT FULLY TIGHTEN, LEAVE 1/2" (12mm) EXPOSED.**

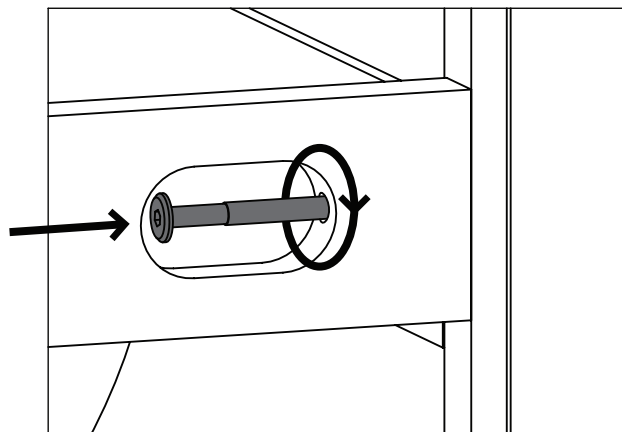

SLIDE THE CRESCENT WASHER OVER THE EXPOSED BOLT, BEHIND THE HEAD OF THE BOLT. TIGHTEN THE BOLT WITH THE ALLEN WRENCH PROVIDED.

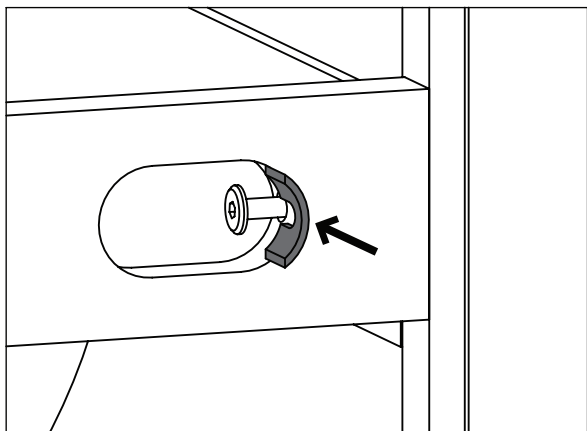

INSTALL (1) BOLT AND (1) CRESCENT WASHER AT A TIME. TIGHTEN UNTIL IT LOOKS LIKE THE PICTURE.

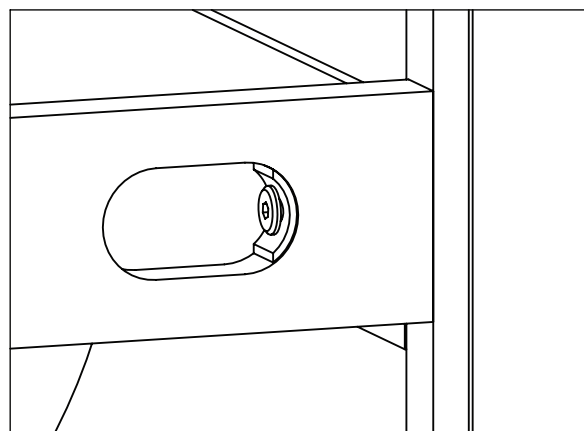

STEP 1:

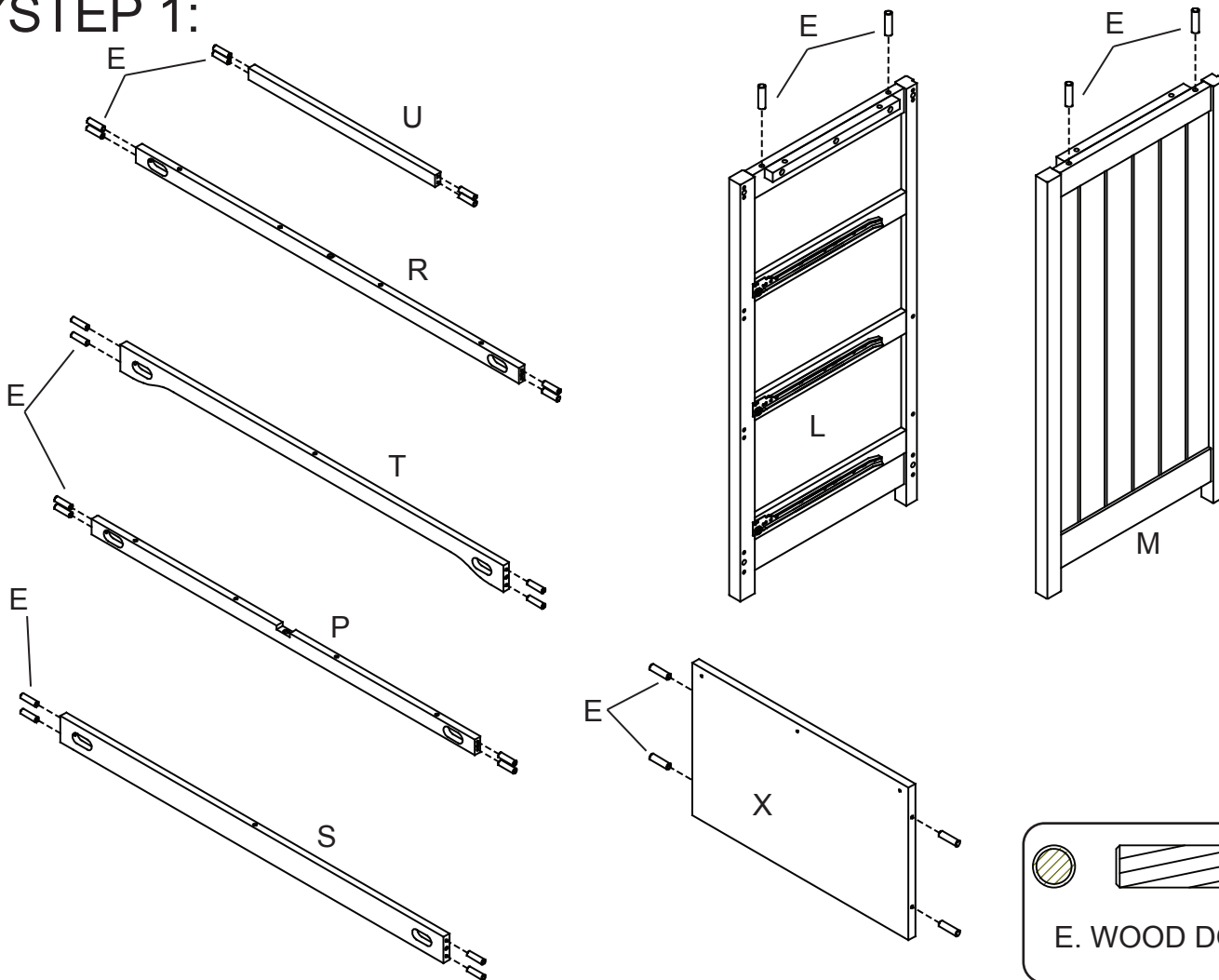

STEP 2:

ATTACH TOP FRONT RAIL (PART R), BOTTOM FRONT RAIL (PART T), TOP BACK RAIL (PART P), BOTTOM BACK RAIL (PART S) TO LEFT SIDE (PART L). ENSURE THAT THE SLOTS ON THE RAILS FACE THE INSIDE. USING (4) 50mm BOLT (PART D) AND (4) CRESCENT WASHERS (PART C). FOLLOW DIRECTION ON PAGE 4. TIGHTEN ALL BOLTS WITH THE ALLEN WRENCH. INSERT (2) MIDDLE FRONT RAIL (PART U) AND (1) BOTTOM BACK PANEL (PART X) WITH THE HOLES TO THE BACK AND FRONT OF LEFT SIDE (PART L).

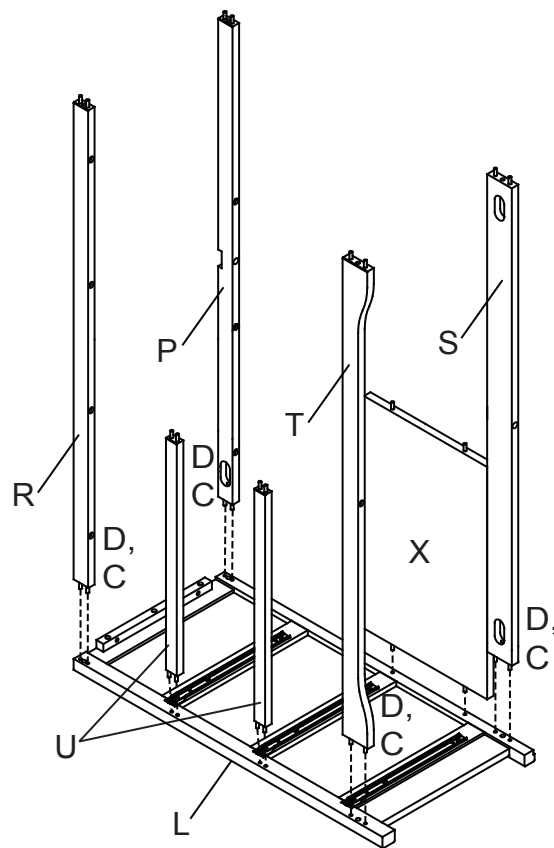
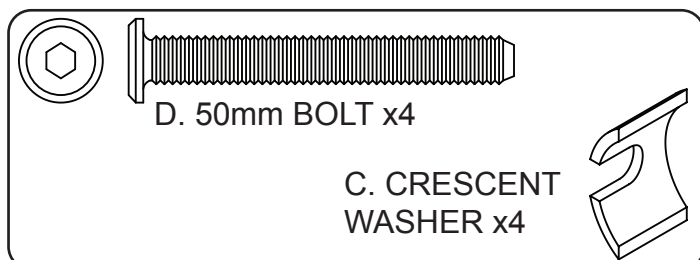

STEP 3:

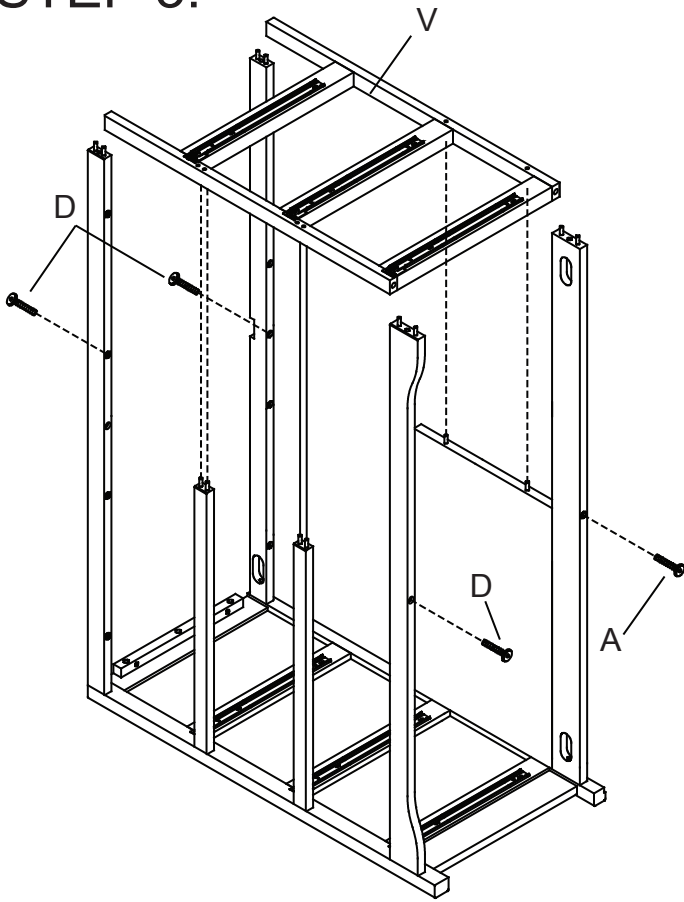

INSERT THE DIVIDER FRAME (PART V) INTO THE (2) MIDDLE FRONT RAILS AND BOTTOM BACK PANEL. CAREFULLY ALIGN ALL OF THE DOWELS WITH THE HOLES IN THE DIVIDER FRAME. USING (3) 50mm BOLTS (PART D) FOR FRONT, BACK TOP RAIL AND FRONT BOTTOM RAIL. USING (1) 75mm BOLT (PART A) FOR BACK BOTTOM RAIL. TIGHTEN ALL BOLTS WITH THE ALLEN WRENCH.

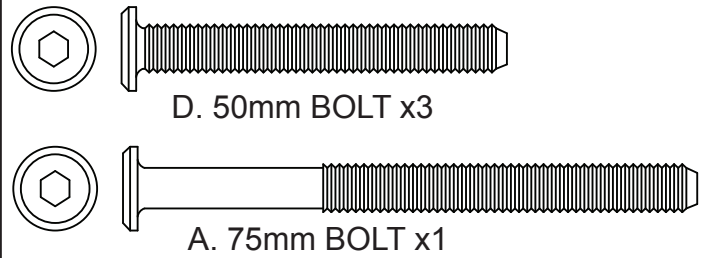

STEP 4:

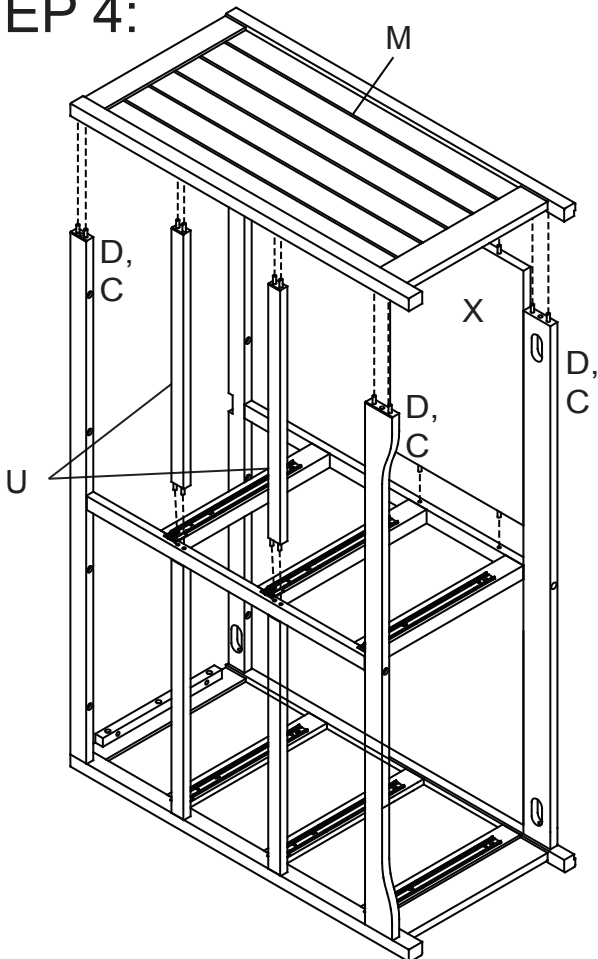

INSERT THE BOTTOM BACK PANEL (PART X) AND THE (2) MIDDLE FRONT RAILS INTO THE DIVIDER FRAME. CAREFULLY ALIGN ALL OF THE DOWELS WITH THE HOLES IN THE RIGHT SIDE (PART M). ATTACHED THE RIGHT SIDE USING (4) 50mm BOLTS (PART D) AND (4) CRESCENT WASHER (PART C) FOLLOWING THE DIRECTION ON PAGE 4. TIGHTEN ALL BOLTS WITH THE ALLEN WRENCH.



STEP 5:

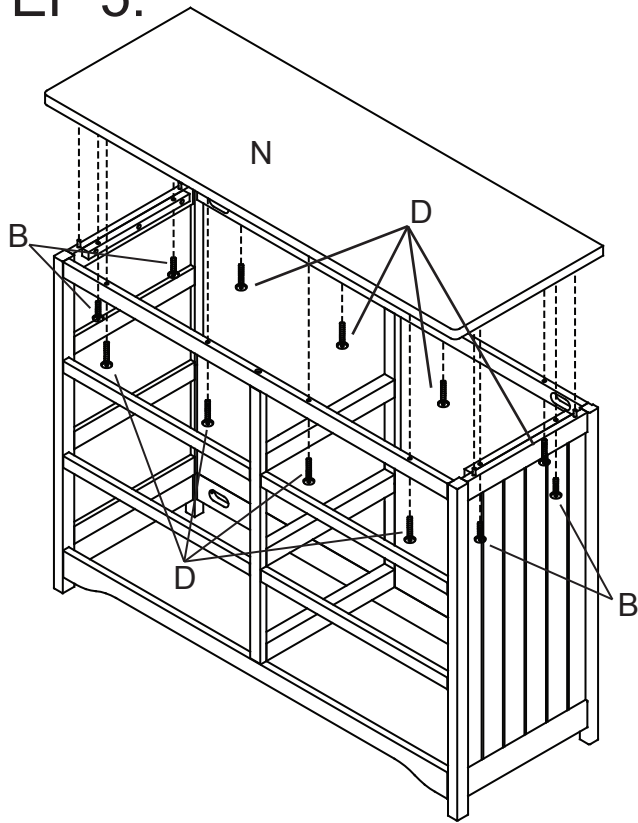

ATTACHED THE TOP PANEL (PART N) TO THE BASE OF THE CASE FROM STEP 4. ENSURE ALL DOWELS ARE ALIGNED PROPERLY BEFORE INSTALLING ANY BOLT. INSTALL (8) 50mm BOLTS (PART D) THROUGH THE TOP FRONT AND BACK RAILS, THEN INSTALL (4) 30mm BOLTS (PART B) THROUGH THE SIDES. TIGHTEN ALL BOLTS WITH THE ALLEN WRENCH.

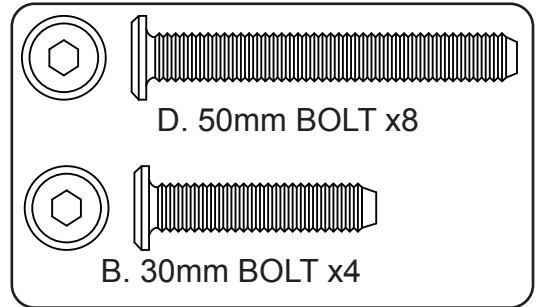

STEP 6:

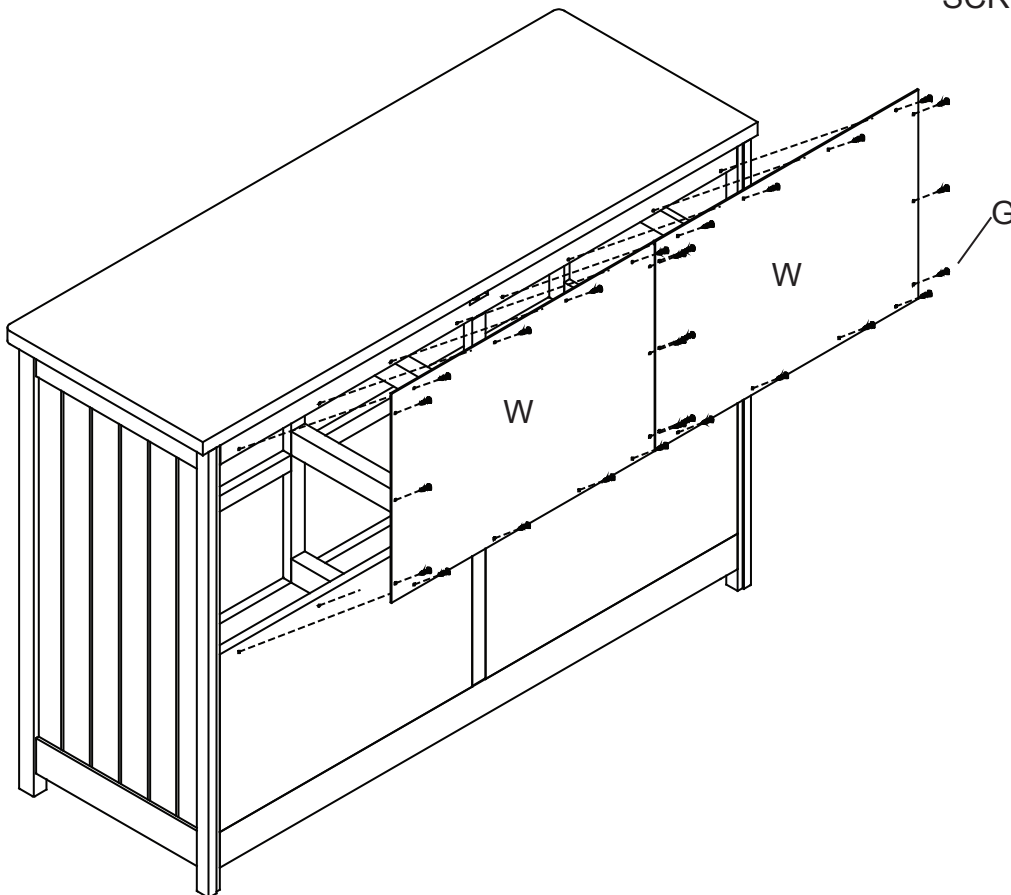

ATTACH BACK PANELS (PART W) USING (24) SCREWS (PART G). TIGHTEN WITH A PHILLIPS SCREWDRIVER.



STEP 7:

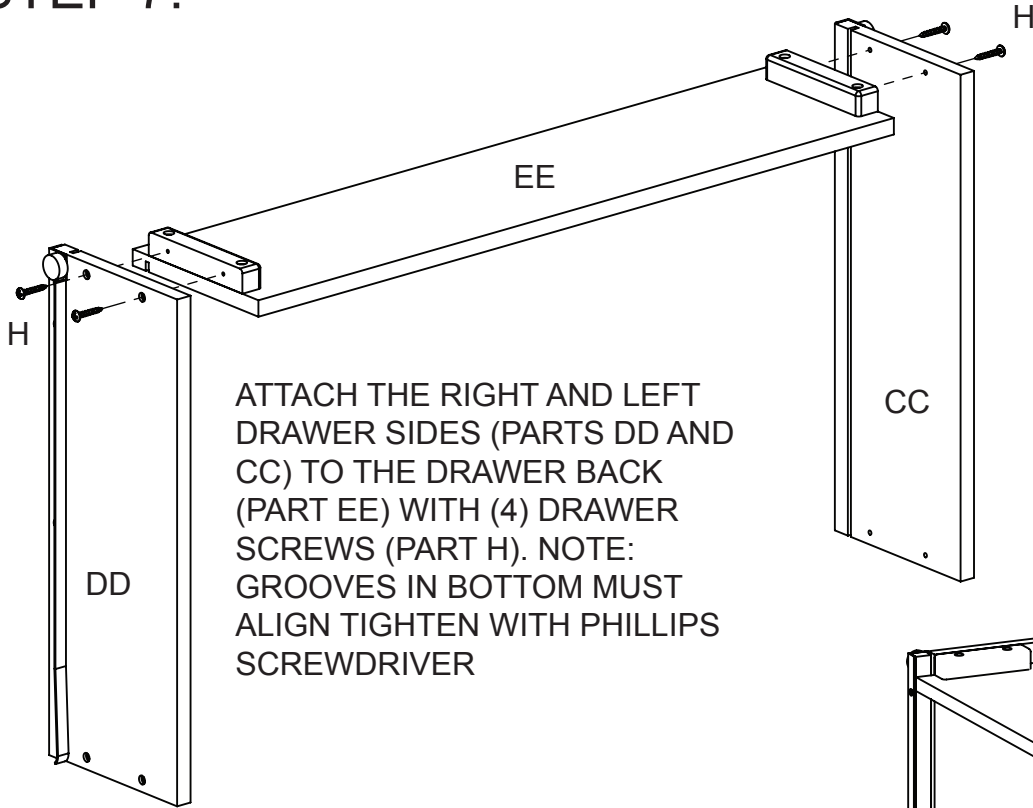

ATTACH THE RIGHT AND LEFT DRAWER SIDES (PARTS DD AND CC) TO THE DRAWER BACK (PART EE) WITH (4) DRAWER SCREWS (PART H). NOTE: GROOVES IN BOTTOM MUST ALIGN TIGHTEN WITH PHILLIPS SCREWDRIVER

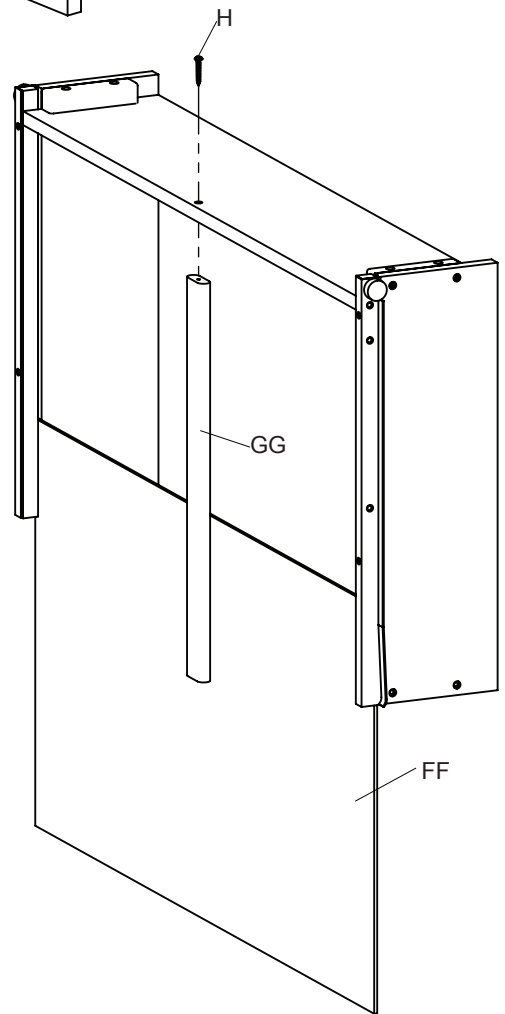

SLIDE DRAWER BOTTOM (PART FF) INTO THE GROOVES. INSTALL THE DRAWER SUPPORT (PART GG) USING ON DRAWER SCREW (PART H)

ATTACH THE DRAWER FRONT (PARTS AA AND BB). USING (4) DRAWER SCREWS (PART H). BE SURE THE BOTTOM PANEL IS IN THE GROOVE. TIGHTEN WITH THE PHILLIPS SCREWDRIVER.

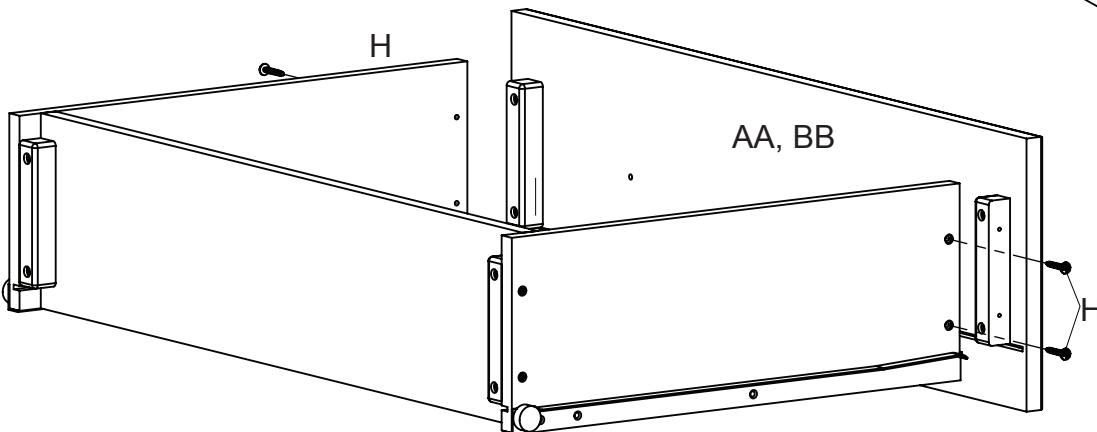

STEP 7: CONTINUED

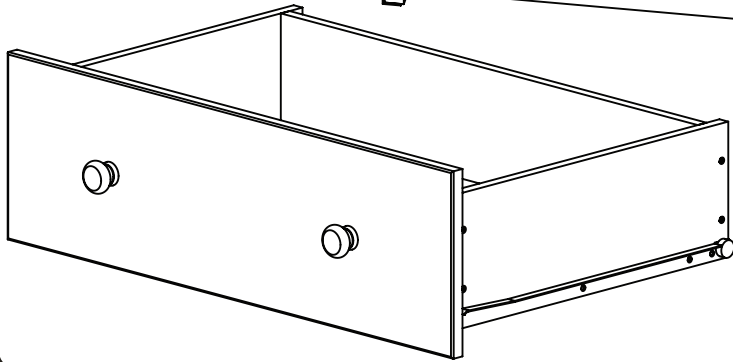
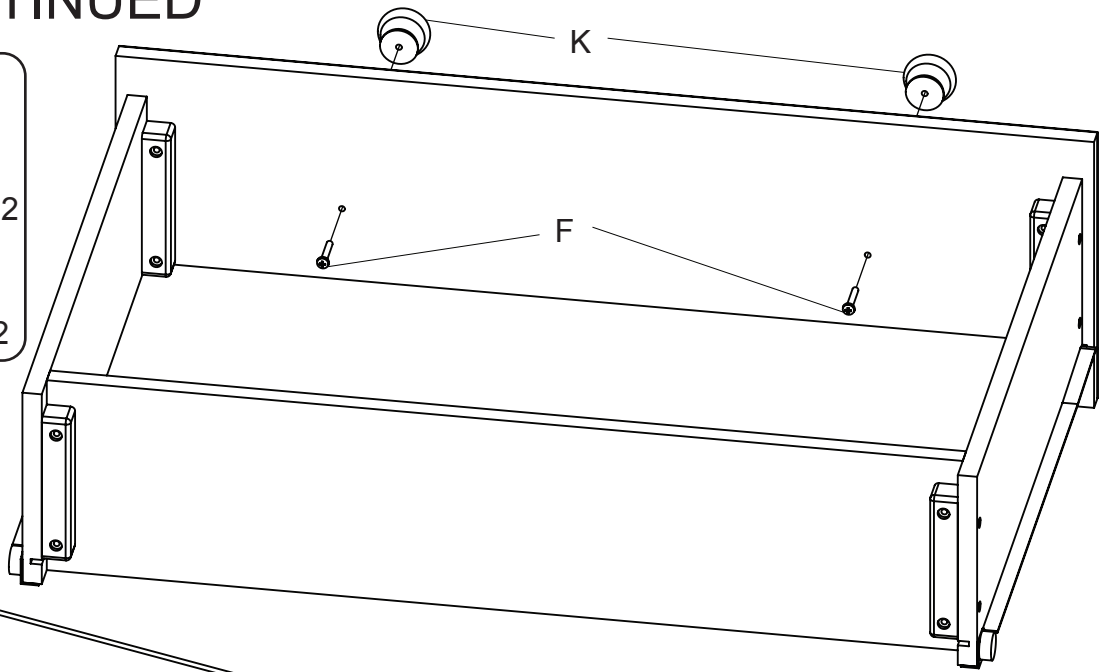
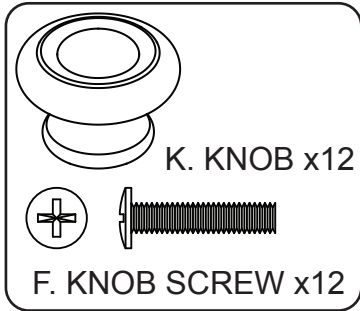

ATTACH (2) KNOBS (PART K)
WITH (2) KNOB SCREWS (PART
F). TIGHTEN WITH THE PHILLIPS
SCREWDRIVER.

6X

STEP 8:

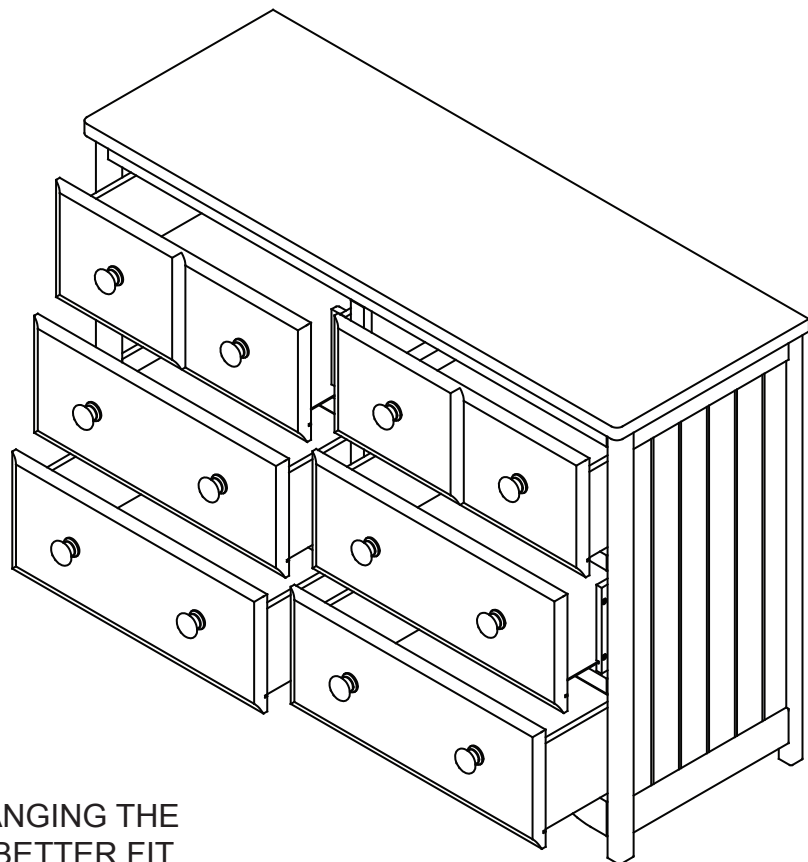

INSTALL DRAWERS. REARRANGING THE
DRAWERS MAY RESULT IN A BETTER FIT
OR ALIGNMENT.



Children's Products

Consumer Care:

www.deltachildrenproducts.com

Delta Children's Products

114 West 26th Street

New York, NY 10001

Tele.212-645-9033

Warranty: This Delta Case is warranted to be free from defects for a period of 90 days from the date of purchase under normal use. This warranty extends only to the original retail purchaser and is valid only when supplied with proof of purchase, or if received as a gift, when the registration is on file with Delta.

Please visit www.deltachildrenproducts.com and click on Product Registration to register your product for important safety alerts and updates.

For questions or comments, please log on to www.deltachildrenproducts.com and click Consumer Care, or contact us by phone at (212) 645-9033.

In the event that you need to contact our Consumer Care department please have the Style Number and Lot Number available. If they are not printed below they can be found on the label on the Back panel.

Use the space below to make note of those numbers.

STYLE No: 74106-

COLOR

REV

FACTORY

Lot No. : _____

Pack Date: _____

Date of Purchase: _____ (you should also keep your receipt)