

Delta™

Children's Products

READ ALL INSTRUCTIONS BEFORE ASSEMBLY AND USE.

KEEP INSTRUCTIONS FOR FUTURE USE.

⚠ ADULT ASSEMBLY REQUIRED

DUE TO THE PRESENCE OF SMALL PARTS DURING ASSEMBLY, KEEP OUT OF REACH OF CHILDREN UNTIL ASSEMBLY IS COMPLETE.

SPRINGTIME 4DRAWER CHEST

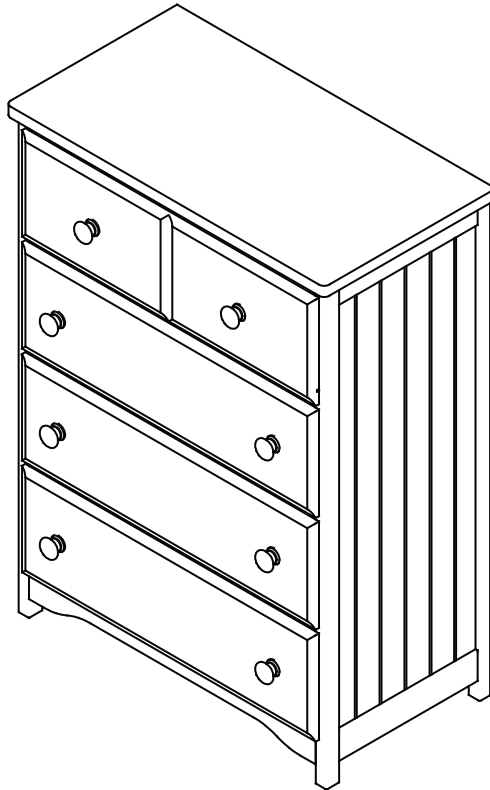

THIS PRODUCT IS NOT INTENDED FOR INSTITUTIONAL OR COMMERCIAL USE.

STYLE No: 74104-



COLOR



REV



FACTORY

When contacting Delta Consumer Care you will need to reference the above number.

Consumer Care:

www.deltachildrensproducts.com

Delta Children's Products

114 West 26th Street

New York, NY 10001

Tele.212-645-9033

To register your product for important safety alerts and updates to your product please visit www.deltachildrensproducts.com and click on Product Registration.

⚠️WARNING:

Serious or fatal crushing injuries can occur from furniture tip-over. To help prevent tip-over:

- Place heaviest items in the lowest drawers.
- Unless specifically designed to accommodate, **do not** set TV's or other heavy objects on the top of this product.
- Never** allow children to climb or hang on drawers, doors, or shelves.
- Never** open more than one drawer at a time.

Use of tip-over restraints may only reduce, but not eliminate, the risk of tip-over.

- Always monitor your child's activity when in the nursery.
- Do not** allow standing in drawers.
- Do not** allow standing on top of this product.
- Accessory Items must be securely fastened to this product according to the instructions provided with those items.
- To avoid head injury, do not allow children to play underneath open drawers.
- Do not leave drawers open when not in use.

NOTES ON ASSEMBLY:

- During the assembly process whenever using screws or bolts, check each by placing the screw/bolt on the diagram of the item which is drawn actual size and design. Be sure to use the proper size and shape specified in the instructions.
- To assemble this unit you may be required to place the unit on it's side and face. It is strongly recommended that assembly is done on a soft, non-abrasive surface to avoid damaging the finish.

NOTES ON CARE AND MAINTENANCE:

- **Do not** scratch or chip the finish.
- Inspect the product periodically, contact delta children's products for replacement parts or questions.
- **Do not** store the product or any parts in extreme temperatures and conditions such as a hot attic or a damp, cold basement. These extremes can cause a loss of structural integrity.
- To preserve the luster of the high quality finish on your product, it is recommended to place a doily or felt pad under any items you place on the finish.
- Clean with a damp cloth, then a dry cloth to preserve the original luster and beauty of this fine finish.
- Do not** use abrasive chemicals.
- Do not** spray cleaners directly onto furniture.
- Lift slightly when moving on carpeting to prevent leg breakage.
- Use of a vaporizer near furniture will cause wood to swell and finish to peel.

PARTS: HARDWARE KITS PART #21396

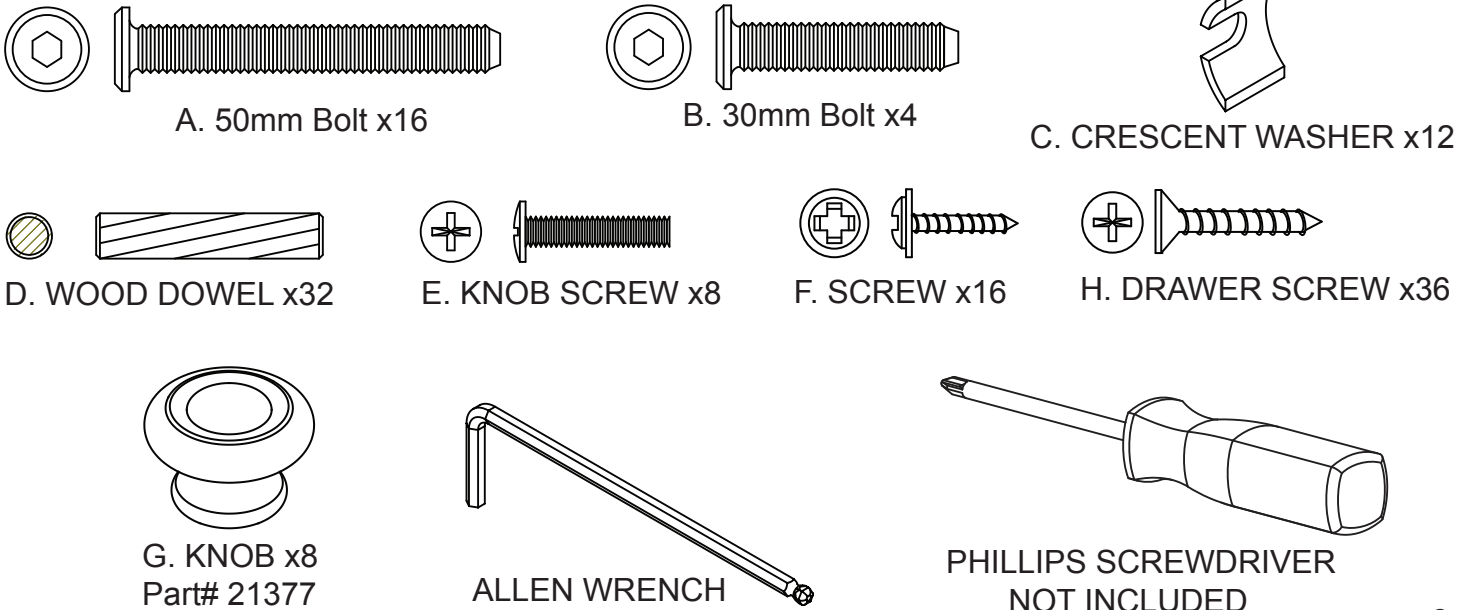

PARTS: MAKE SURE THAT ALL PRE-ASSEMBLED PARTS ARE TIGHT.

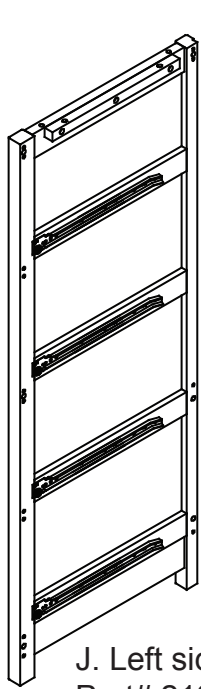

J. Left side
Part# 21378

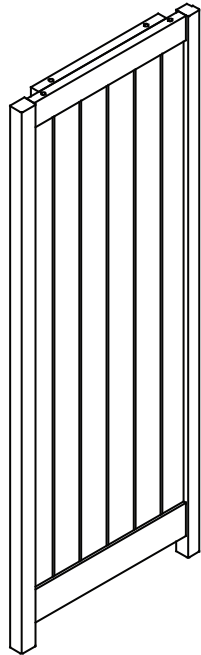

K. Right side
Part# 21379

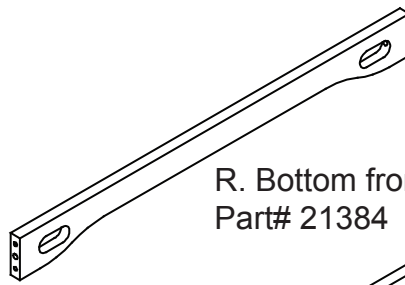

R. Bottom front rail x1
Part# 21384

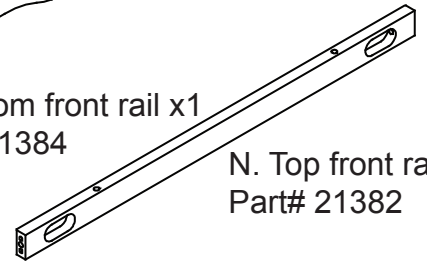

N. Top front rail x1
Part# 21382

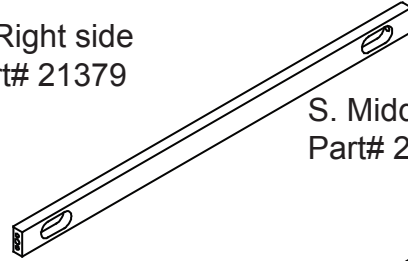

S. Middle front rail x1
Part# 21385

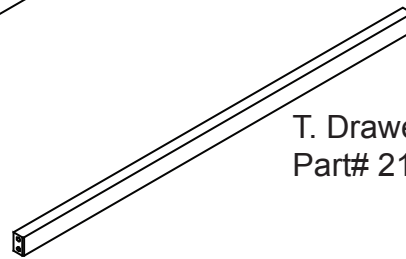

T. Drawer rail x2
Part# 21386

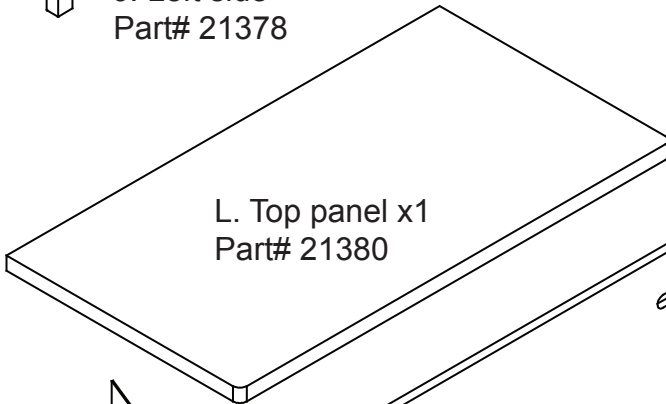

L. Top panel x1
Part# 21380

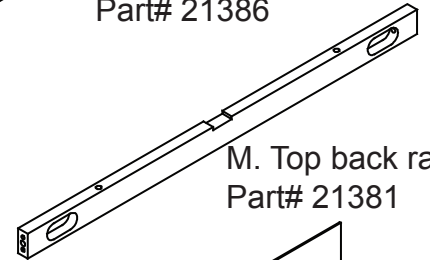

M. Top back rail x1
Part# 21381

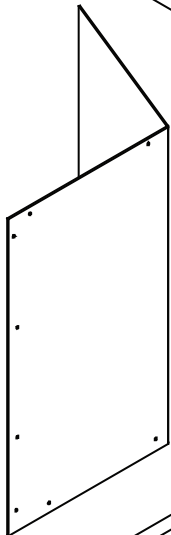

U. Back panel x1
Part# 21387

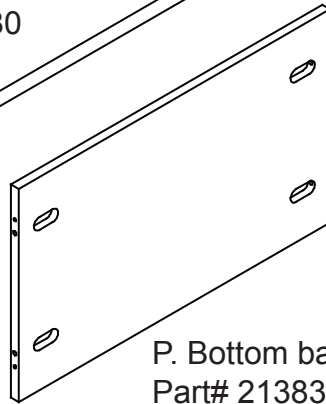

P. Bottom back panel x1
Part# 21383

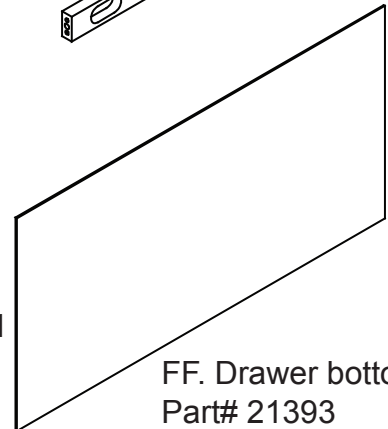

FF. Drawer bottom x4
Part# 21393

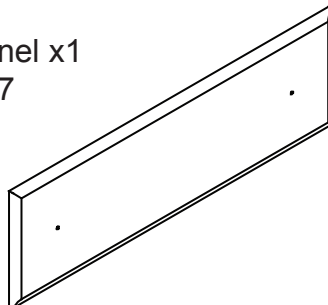

BB. Drawer front x3
Part# 21389

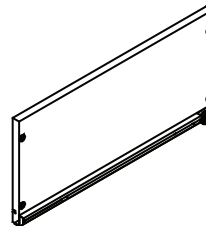

DD. Drawer right side x4
Part# 21391

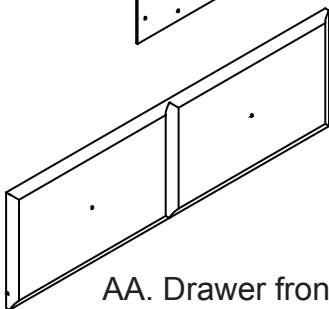

AA. Drawer front-Vein line x1
Part# 21388

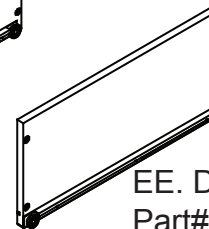

EE. Drawer left side x4
Part# 21392

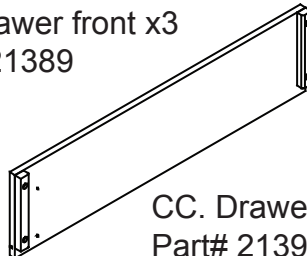

CC. Drawer back x4
Part# 21390

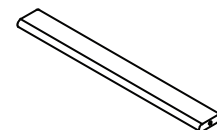

GG. Drawer support x4
Part# 21394

HARDWARE SYSTEM - REVIEW BEFORE ASSEMBLY

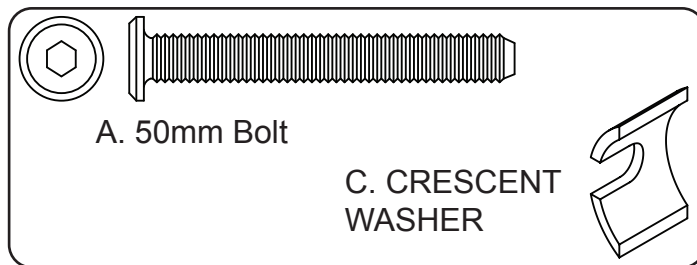
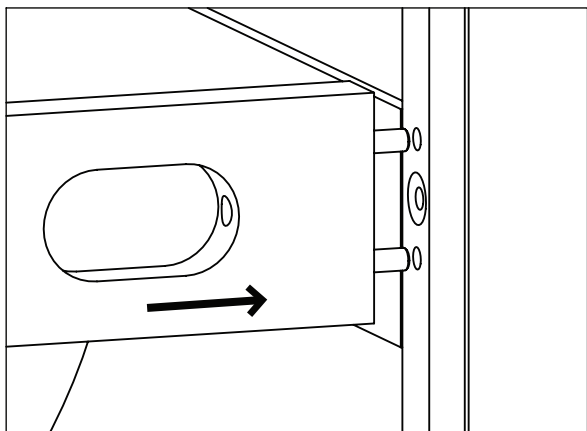

INSERT THE DOWELS IN THE RAIL INTO THE HOLES IN THE E POST.

INSERT THE BOLT INTO THE SLOT. TURN CLOCKWISE WITH FINGERS OR THE ALLEN WRENCH PROVIDED. **DO NOT FULLY TIGHTEN, LEAVE 1/2" (12mm) EXPOSED.**

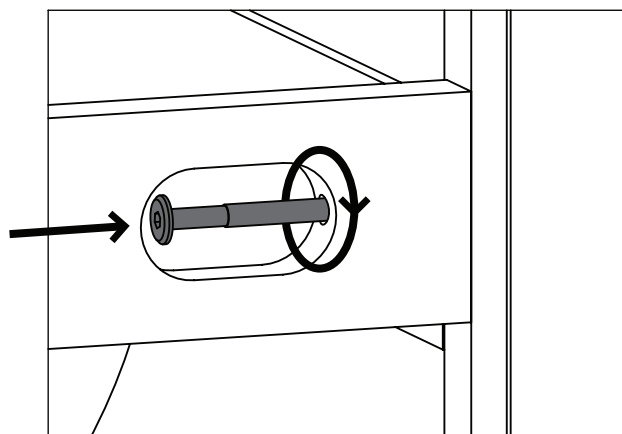

SLIDE THE CRESCENT WASHER OVER THE EXPOSED BOLT, BEHIND THE HEAD OF THE BOLT. TIGHTEN THE BOLT WITH THE ALLEN WRENCH PROVIDED.

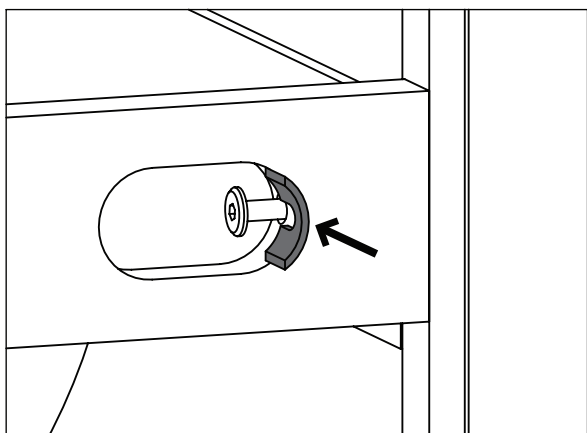

INSTALL (1) BOLT AND (1) CRESCENT WASHER AT A TIME. TIGHTEN UNTIL IT LOOKS LIKE THE PICTURE.

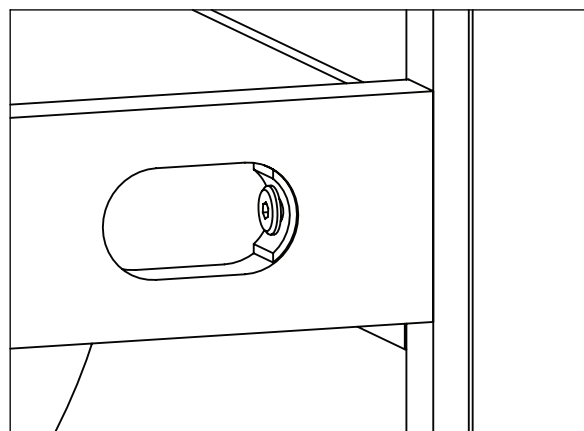

STEP 1:

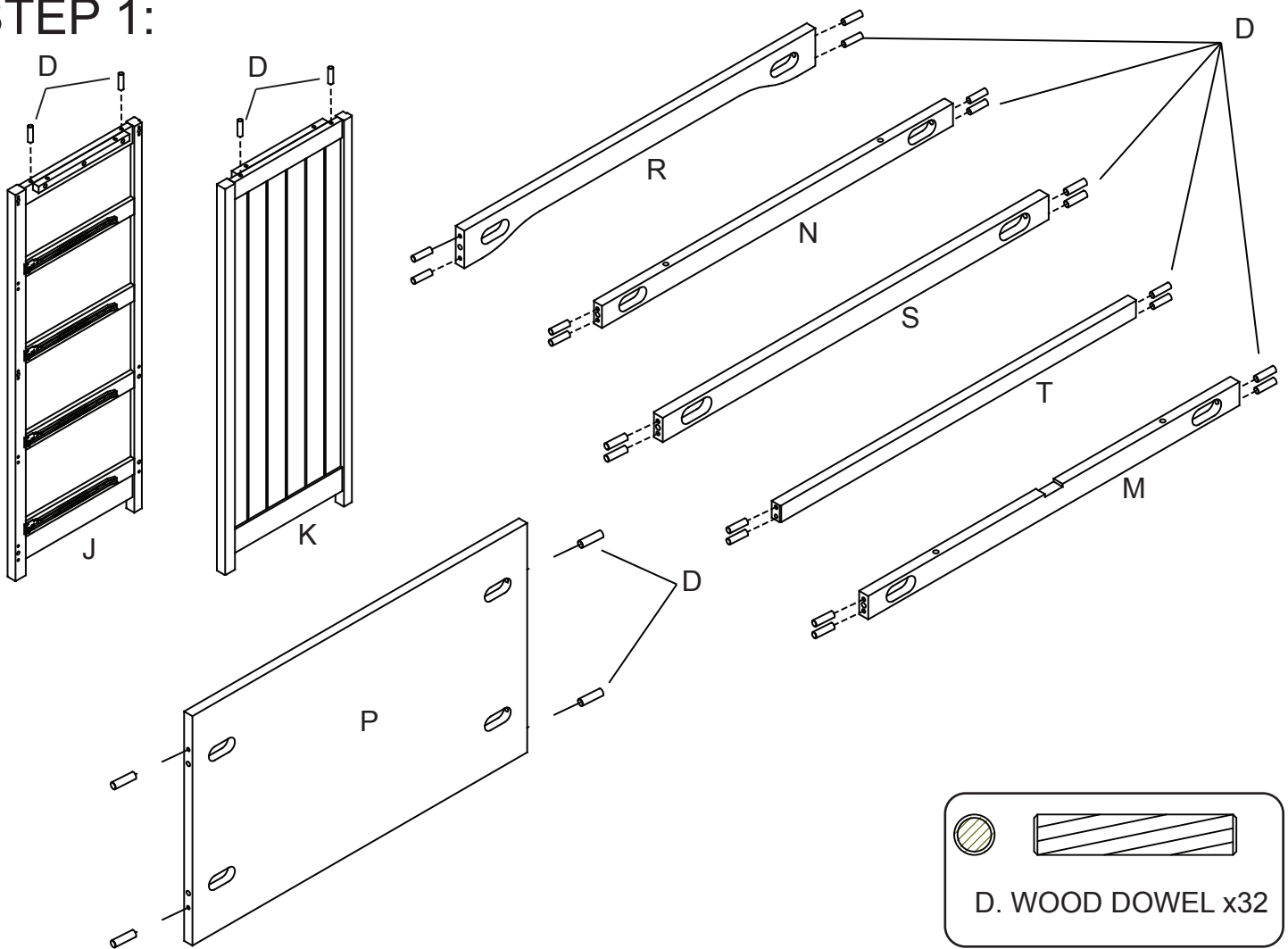

STEP 2:

ATTACH THE TOP FRONT RAIL (PART N), DRAWER RAIL (PART T), MIDDLE FRONT RAIL (PART S), BOTTOM FRONT RAIL (PART R), BACK TOP RAIL (PART M), BOTTOM BACK PANEL (PART P). ENSURE ALL DOWELS ARE ALIGNED BEFORE ANY BOTL. USING (6) BOLT (PART A) AND (6) CRESCENT WASHER (PART C). FOLLOW DIRECTION ON PAGE 4, THEN INSTALL SHORT BOLTS. TIGHTEN ALL BOLTS WITH THE ALLEN WRENCH.

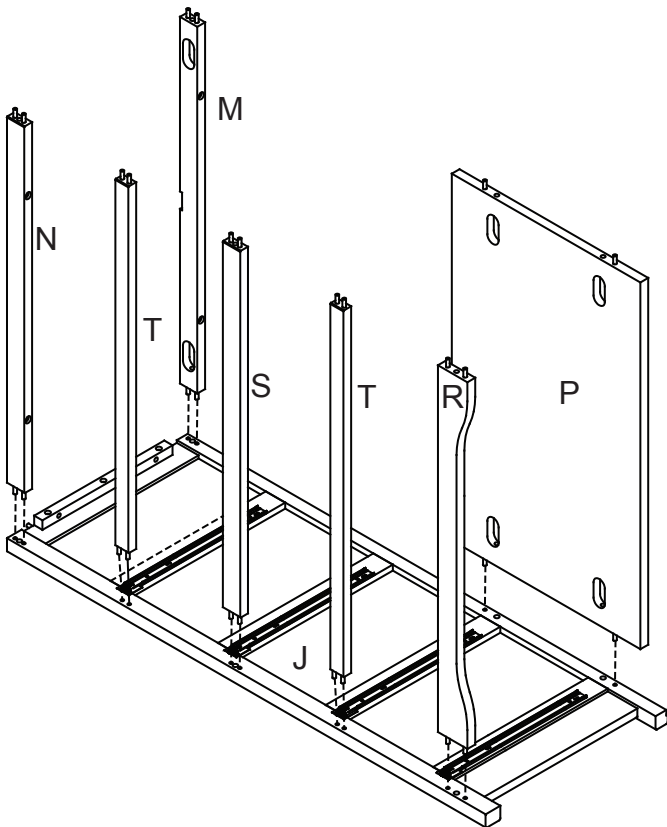

A. 50mm Bolt x6

C. CRESCENT
WASHER x6



STEP 3:

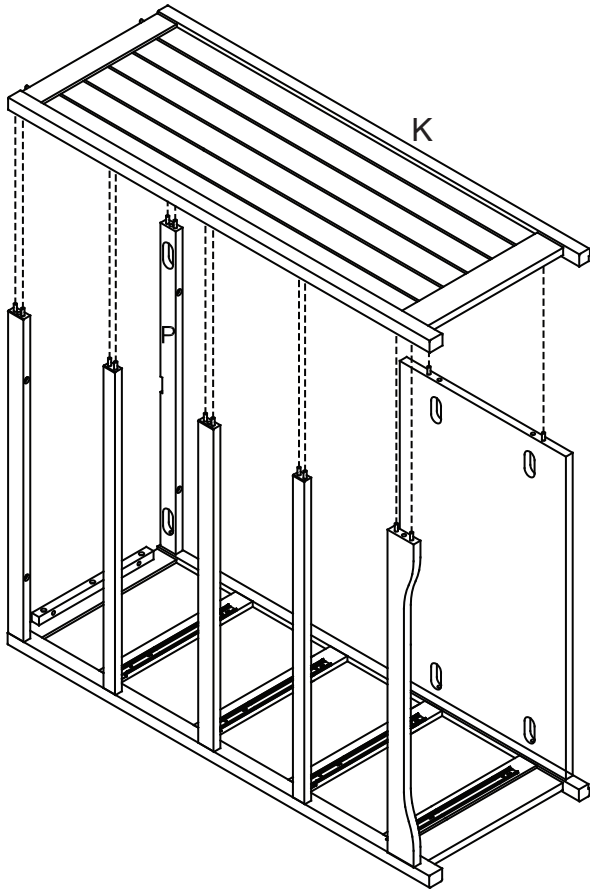

ATTACH THE RIGHT SIDE (PART K) TO THE ASSEMBLY FROM STEP 2. ENSURE ALL DOWELS ARE ALIGNED BEFORE ANY BOLTS. USING (6) BOLT (PART A) AND (6) CRESCENT WASHER (PART C). FOLLOW DIRECTION ON PAGE 4, THEN INSTALL SHORT BOLTS. TIGHTEN ALL BOLTS WITH THE ALLEN WRENCH.

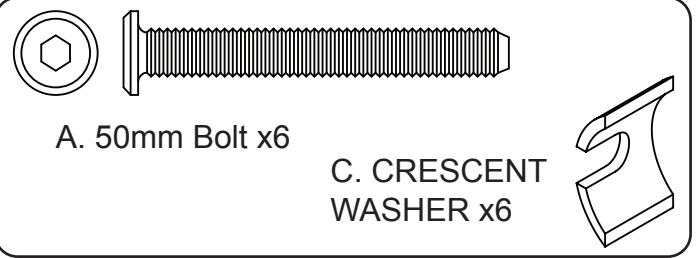

STEP 4:

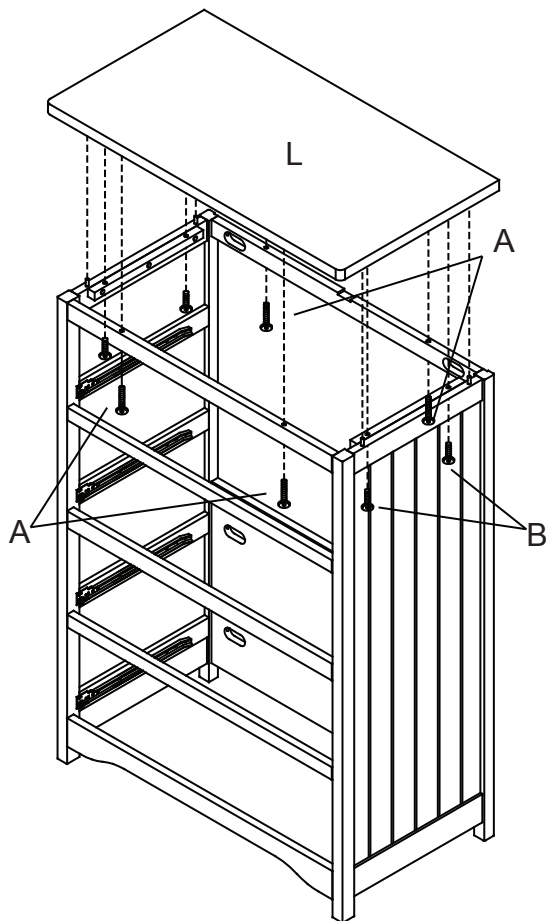

ATTACHED THE TOP PANEL (PART L) TO THE BASE OF THE CASE FROM STEP 3. ENSURE ALL DOWELS ARE ALIGNED BEFORE INSTALLING ANY BOLTS. INSTALL (4) BOLTS (PART A) THROUGH THE TOP FRONT AND BACK RAILS, THEN INSTALL (4) BOLTS (PART B) THROUGH THE SIDE. TIGHTEN ALL BOLTS WITH THE ALLEN WRENCH.

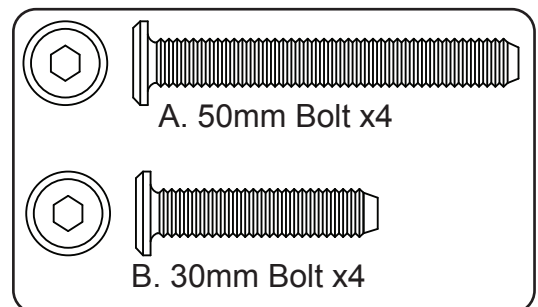

STEP 5:

ATTACH BACK PANEL (PART U)
USING (16) SCREWS (PART F).
TIGHTEN WITH A PHILLIPS
SCREWDRIVER.

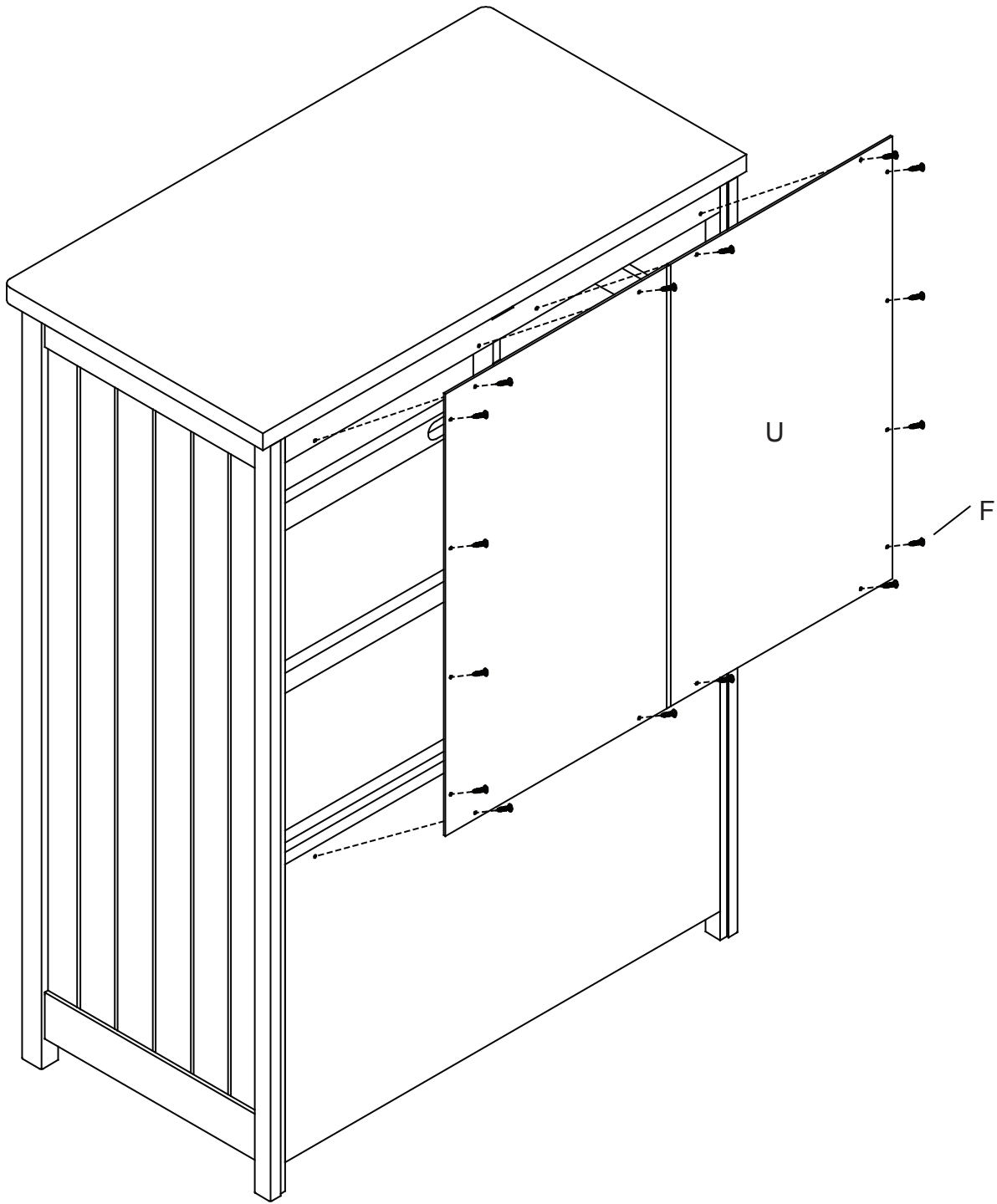

STEP 6:

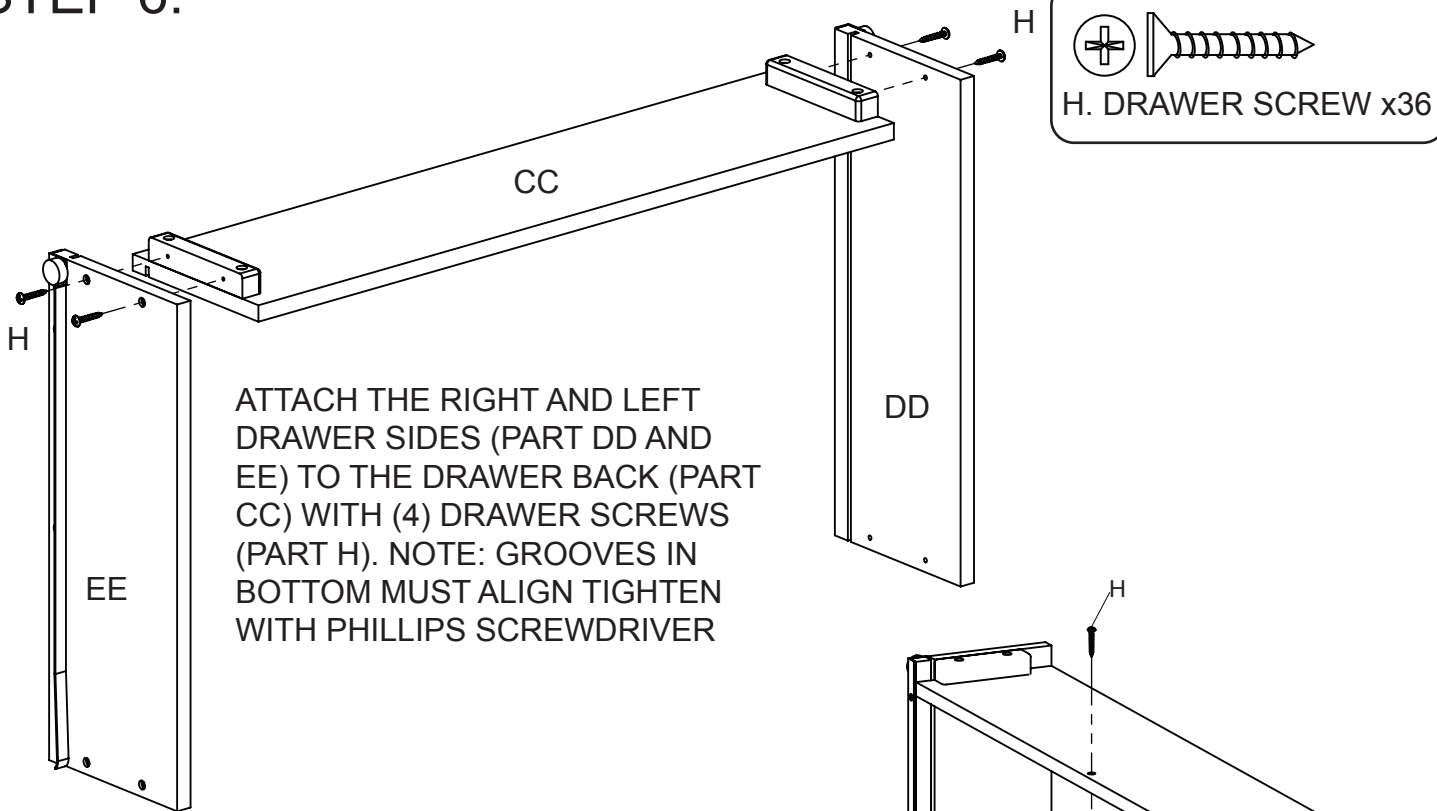

SLIDE DRAWER BOTTOM (PART GG) INTO THE GROOVES. INSTALL THE DRAWER SUPPORT (PART FF) USING ON DRAWER SCREW (PART H)

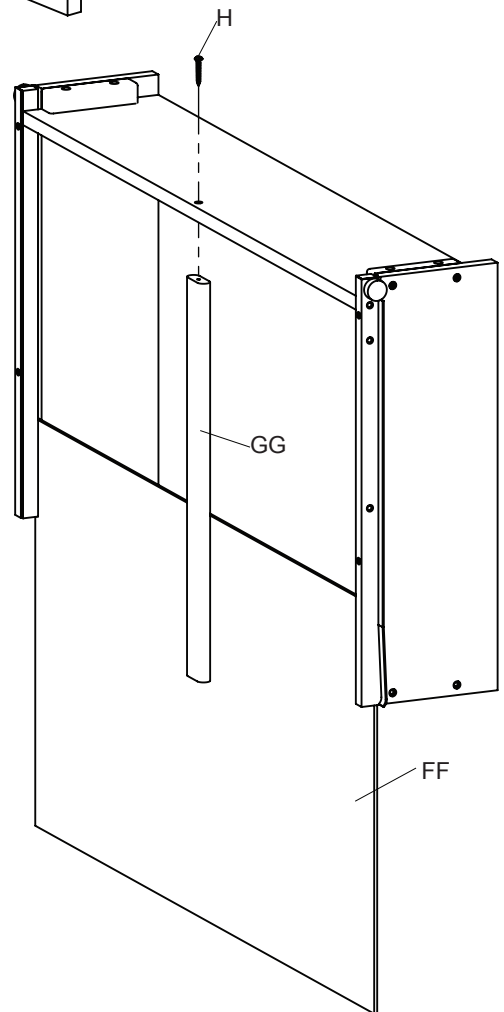

ATTACH THE DRAWER FRONT (PART AA, BB). USING (4) DRAWER SCREWS (PART H). BE SURE THE BOTTOM PANEL IS IN THE GROOVE. TIGHTEN WITH THE PHILLIPS SCREWDRIVER.

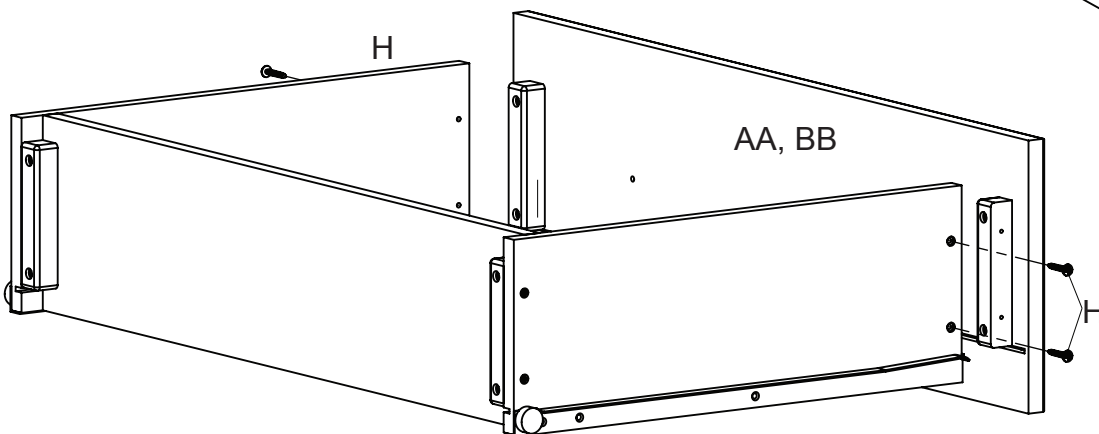

STEP 6: CONTINUED

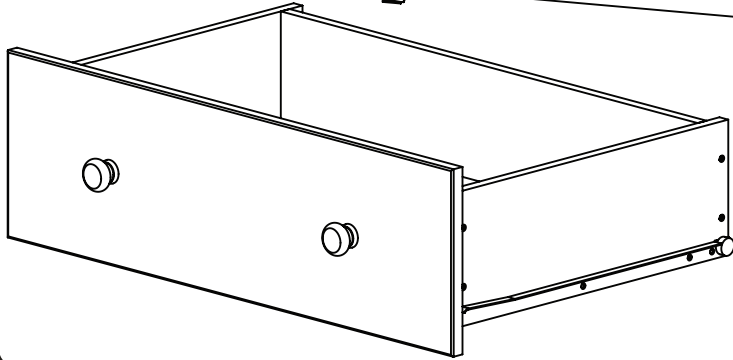
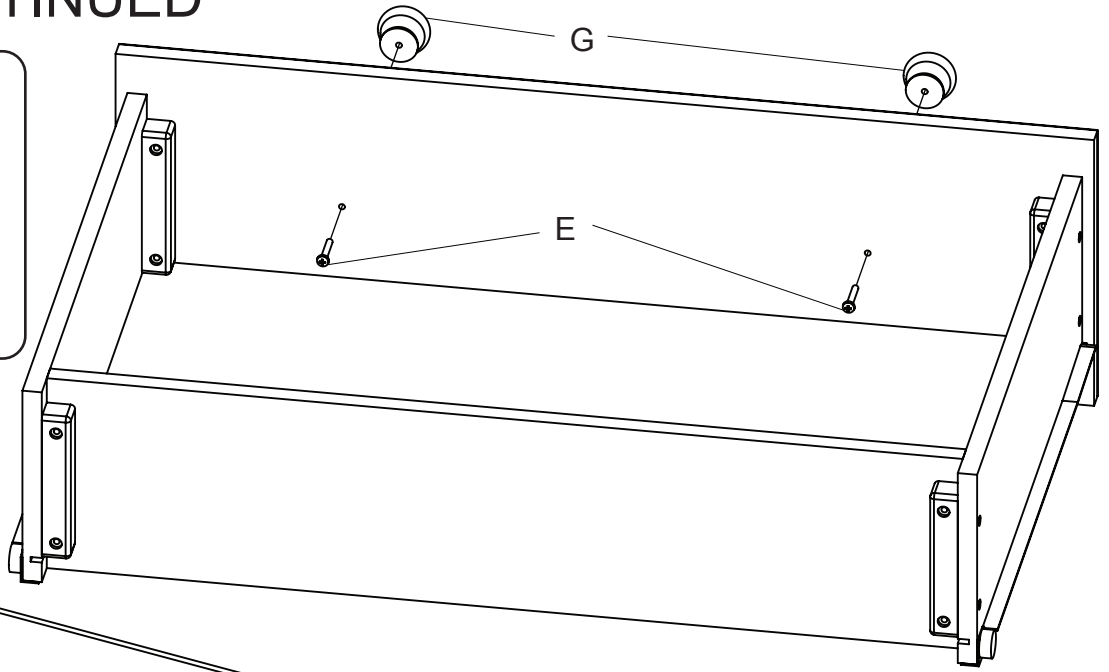
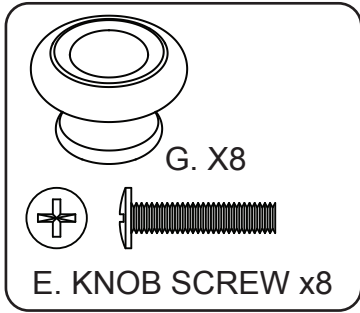

ATTACH (2) KNOBS (PART G)
WITH (2) KNOB SCREWS (PART
E). TIGHTEN WITH THE PHILLIPS

4X

STEP 8:

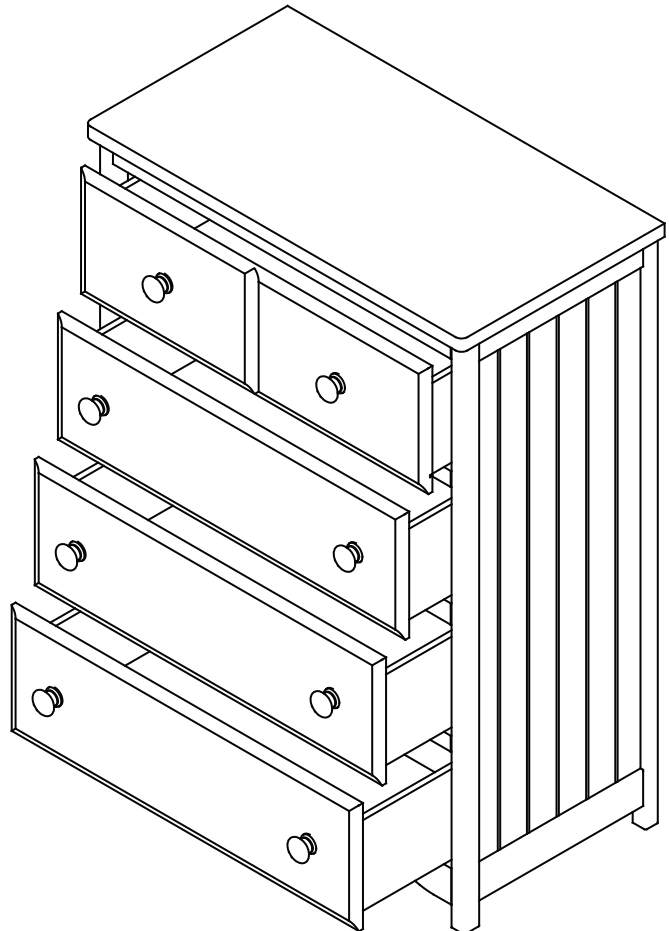

INSTALL DRAWERS. REARRANGING THE
DRAWERS MAY RESULT IN A BETTER FIT
OR ALIGNMENT.



Children's Products

Consumer Care:

www.deltachildrenproducts.com

Delta Children's Products

114 West 26th Street

New York, NY 10001

Tele.212-645-9033

Warranty: This Delta Case is warranted to be free from defects for a period of 90 days from the date of purchase under normal use. This warranty extends only to the original retail purchaser and is valid only when supplied with proof of purchase, or if received as a gift, when the registration is on file with Delta.

Please visit www.deltachildrenproducts.com and click on Product Registration to register your product for important safety alerts and updates.

For questions or comments, please log on to www.deltachildrenproducts.com and click Consumer Care, or contact us by phone at (212) 645-9033.

In the event that you need to contact our Consumer Care department please have the Style Number and Lot Number available. If they are not printed below they can be found on the label on the Back panel.

Use the space below to make note of those numbers.

STYLE No: 74104-

COLOR

REV

FACTORY

Lot No. : _____

Pack Date: _____

Date of Purchase: _____ (you should also keep your receipt)