

Delta™

Children's Products

READ ALL INSTRUCTIONS BEFORE
ASSEMBLY AND USE.

KEEP INSTRUCTIONS FOR FUTURE USE.

⚠ ADULT ASSEMBLY REQUIRED

DUE TO THE PRESENCE OF SMALL PARTS
DURING ASSEMBLY, KEEP OUT OF REACH OF
CHILDREN UNTIL ASSEMBLY IS COMPLETE.

NEWPORT 3DRAWER CHEST

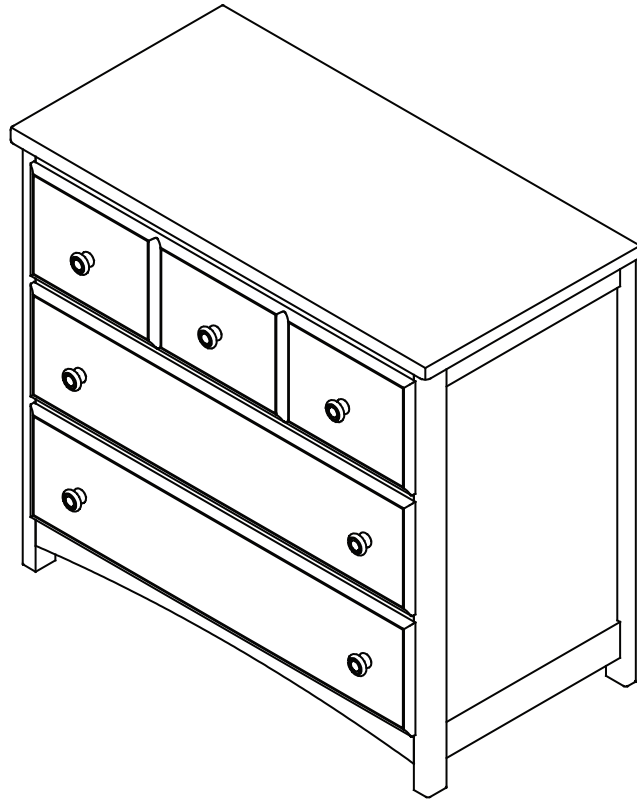

THIS PRODUCT IS NOT INTENDED FOR INSTITUTIONAL OR COMMERCIAL USE.

STYLE No: 74103-



COLOR



REV



FACTORY

When contacting Delta Consumer Care you
will need to reference the above number.

Consumer Care:

www.deltachildrensproducts.com

Delta Children's Products

114 West 26th Street

New York, NY 10001

Tele.212-645-9033

To register your product for important safety alerts and updates to your product
please visit www.deltachildrensproducts.com and click on Product Registration.

⚠WARNING:

Serious or fatal crushing injuries can occur from furniture tip-over. To help prevent tip-over:

- Place heaviest items in the lowest drawers.
- Unless specifically designed to accommodate, **do not** set TV's or other heavy objects on the top of this product.
- Never** allow children to climb or hang on drawers, doors, or shelves.
- Never** open more than one drawer at a time.

Use of tip-over restraints may only reduce, but not eliminate, the risk of tip-over.

- Always monitor your child's activity when in the nursery.
- Do not** allow standing in drawers.
- Do not** allow standing on top of this product.
- Accessory Items must be securely fastened to this product according to the instructions provided with those items.
- To avoid head injury, do not allow children to play underneath open drawers.
- Do not leave drawers open when not in use.

NOTES ON ASSEMBLY:

- During the assembly process whenever using screws or bolts, check each by placing the screw/bolt on the diagram of the item which is drawn actual size and design. Be sure to use the proper size and shape specified in the instructions.
- To assemble this unit you may be required to place the unit on it's side and face. It is strongly recommended that assembly is done on a soft, non-abrasive surface to avoid damaging the finish.

NOTES ON CARE AND MAINTENANCE:

- **Do not** scratch or chip the finish.
- Inspect the product periodically, contact delta children's products for replacement parts or questions.
- **Do not** store the product or any parts in extreme temperatures and conditions such as a hot attic or a damp, cold basement. These extremes can cause a loss of structural integrity.
- To preserve the luster of the high quality finish on your product, it is recommended to place a doily or felt pad under any items you place on the finish.
- Clean with a damp cloth, then a dry cloth to preserve the original luster and beauty of this fine finish.
- Do not** use abrasive chemicals.
- Do not** spray cleaners directly onto furniture.
- Lift slightly when moving on carpeting to prevent leg breakage.
- Use of a vaporizer near furniture will cause wood to swell and finish to peel.

PARTS: HARDWARE KITS PART #21463

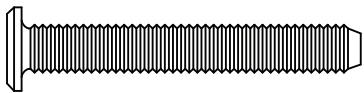

A. 45mm Bolt x14

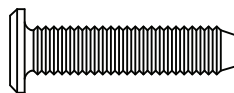

B. 28mm Bolt x4



C. CRESCENT WASHER x10



D. WOOD DOWEL x28



E. KNOB SCREW x7

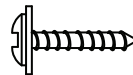

F. SCREW x16

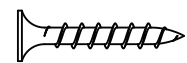

H. DRAWER SCREW x27

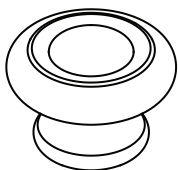

G. KNOB x7
Part# 21445

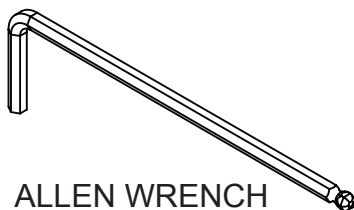

ALLEN WRENCH

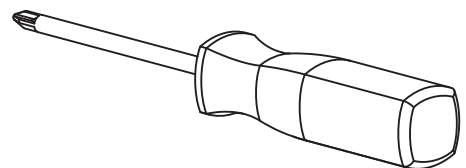

PHILLIPS SCREWDRIVER
NOT INCLUDED

PARTS: MAKE SURE THAT ALL PRE-ASSEMBLED PARTS ARE TIGHT.

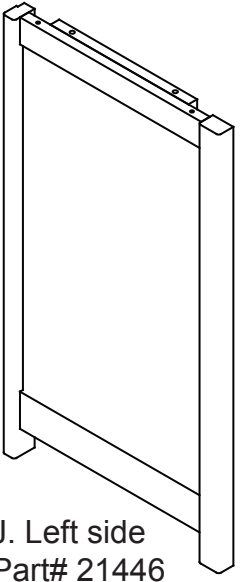

J. Left side
Part# 21446

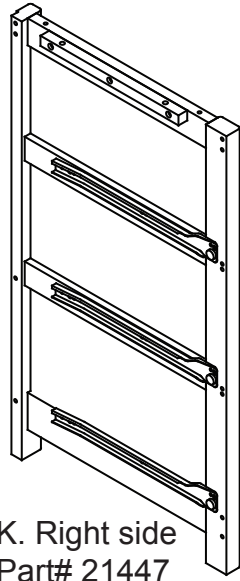

K. Right side
Part# 21447

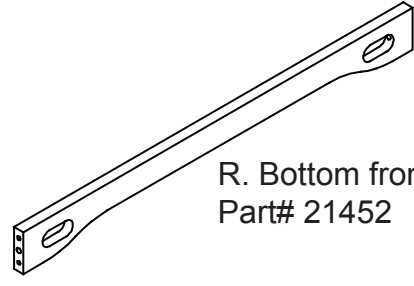

R. Bottom front rail x1
Part# 21452

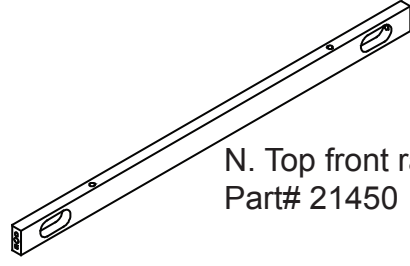

N. Top front rail x1
Part# 21450

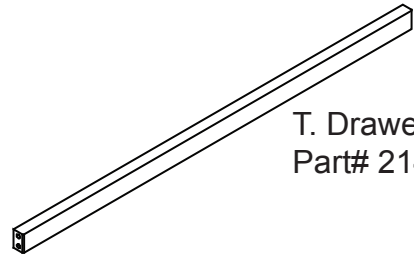

T. Drawer rail x2
Part# 21453

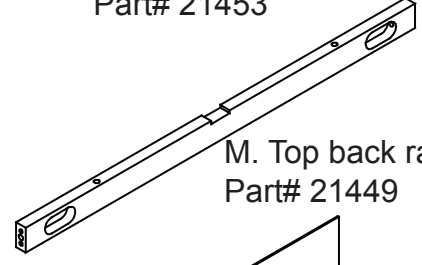

M. Top back rail x1
Part# 21449

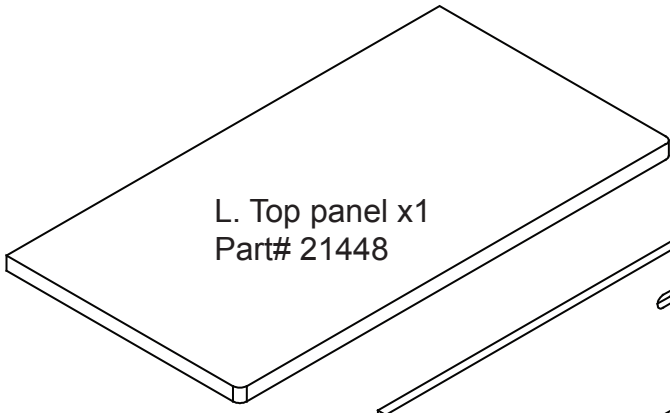

L. Top panel x1
Part# 21448

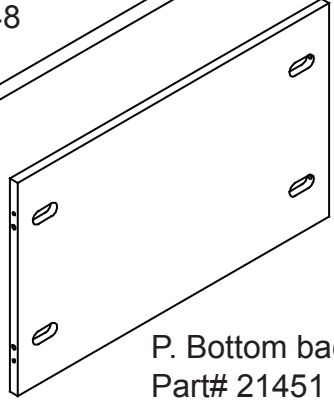

P. Bottom back panel x1
Part# 21451

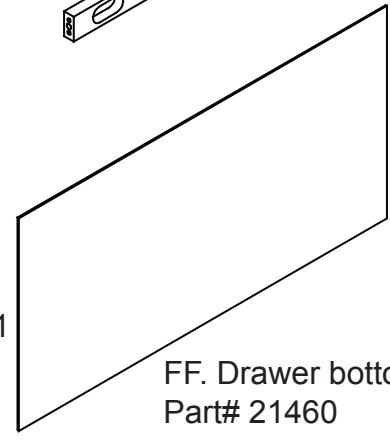

FF. Drawer bottom x3
Part# 21460

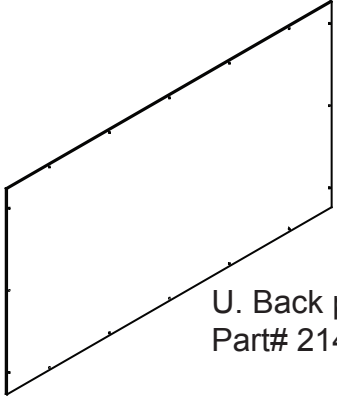

U. Back panel x1
Part# 21454

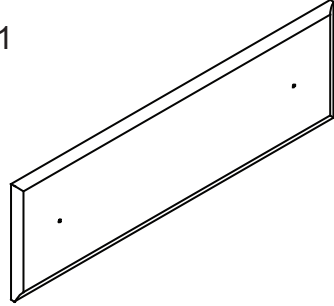

BB. Drawer front x2
Part# 21456

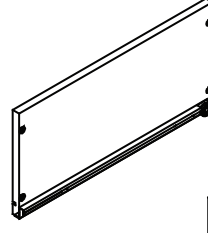

DD. Drawer right side x3
Part# 21458

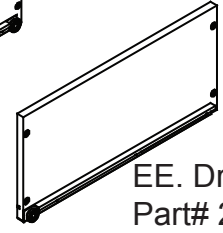

EE. Drawer left side x3
Part# 21459

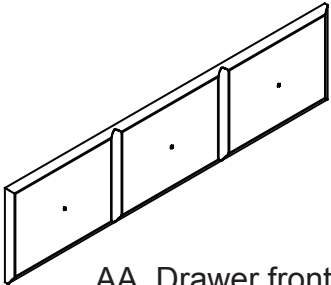

AA. Drawer front-Vein line x1
Part# 21455

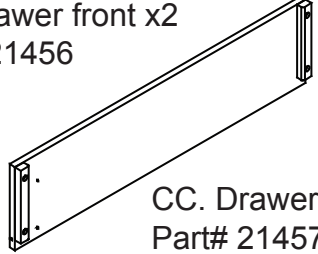

CC. Drawer back x3
Part# 21457

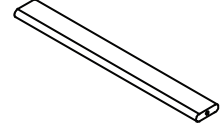

GG. Drawer support x3
Part# 21461z

HARDWARE SYSTEM - REVIEW BEFORE ASSEMBLY

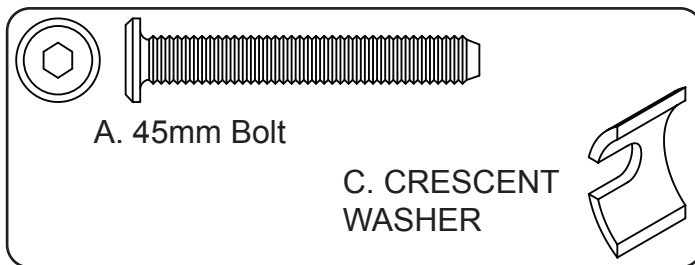
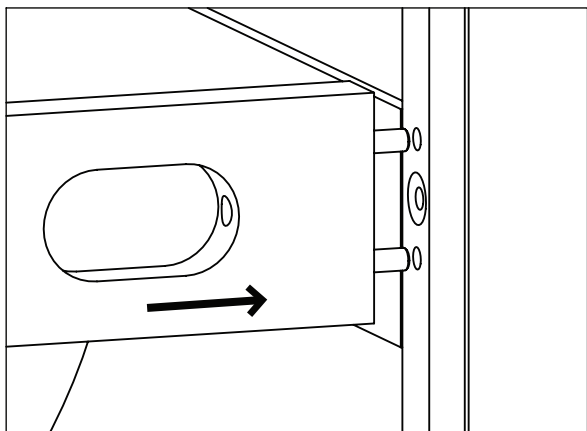

INSERT THE DOWELS IN THE RAIL INTO THE HOLES IN THE E POST.

INSERT THE BOLT INTO THE SLOT. TURN CLOCKWISE WITH FINGERS OR THE ALLEN WRENCH PROVIDED. **DO NOT FULLY TIGHTEN, LEAVE 1/2" (12mm) EXPOSED.**

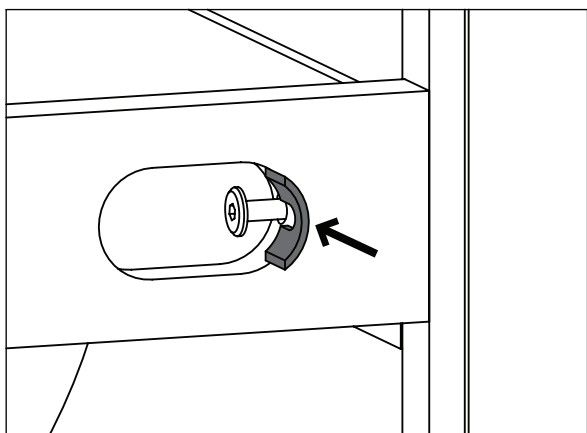
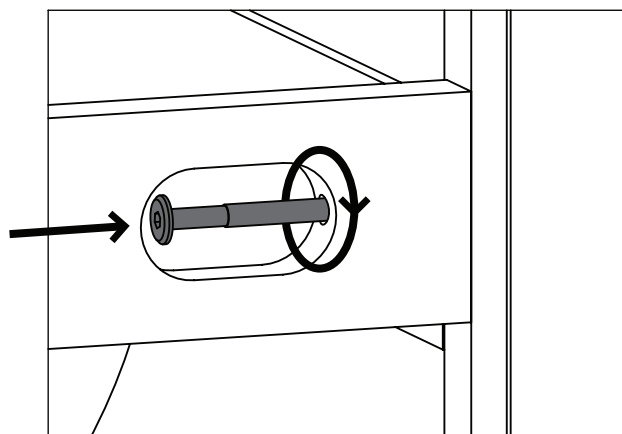

SLIDE THE CRESCENT WASHER OVER THE EXPOSED BOLT, BEHIND THE HEAD OF THE BOLT. TIGHTEN THE BOLT WITH THE ALLEN WRENCH PROVIDED.

INSTALL (1) BOLT AND (1) CRESCENT WASHER AT A TIME. TIGHTEN UNTIL IT LOOKS LIKE THE PICTURE.

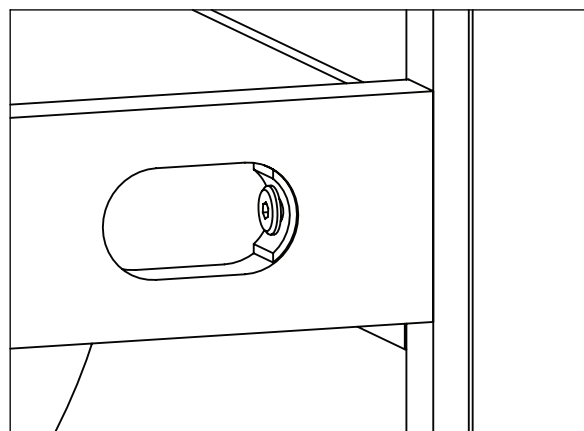

STEP 1:

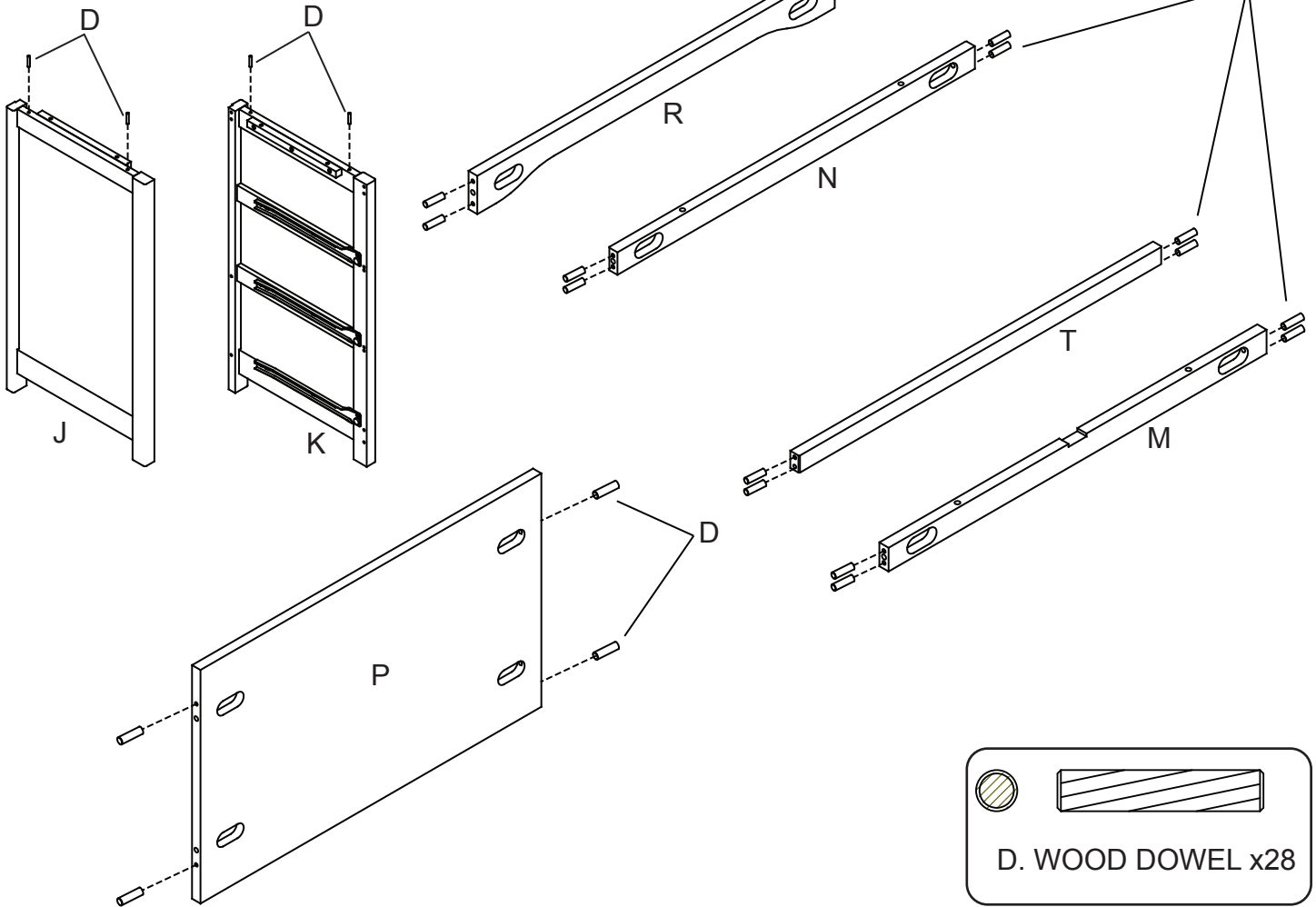

D. WOOD DOWEL x28

STEP 2:

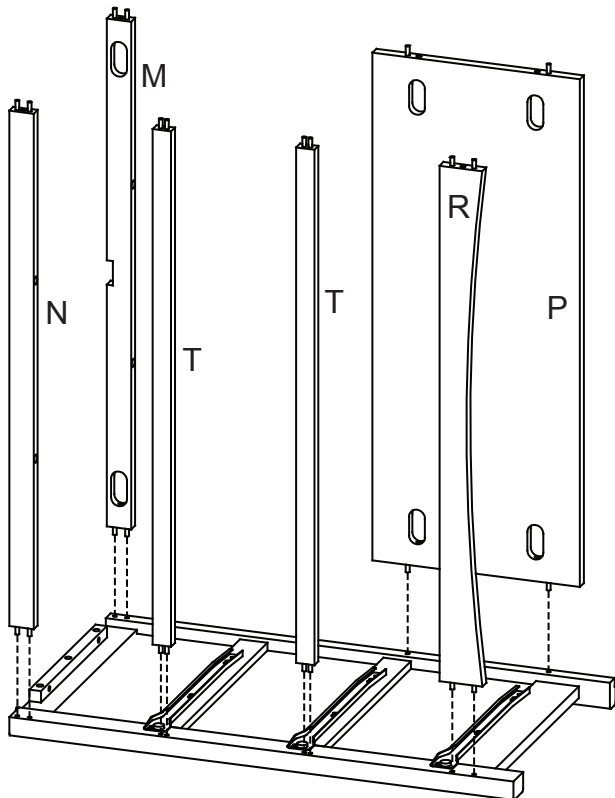

ATTACH THE TOP FRONT RAIL (PART N), DRAWER RAIL (PART T), BOTTOM FRONT RAIL (PART R), BACK TOP RAIL (PART M), BOTTOM BACK PANEL (PART P). ENSURE ALL DOWELS ARE ALIGNED BEFORE ANY BOTL. USING (10) BOLT (PART A) AND (10) CRESCENT WASHER (PART C). FOLLOW DIRECTION ON PAGE 4, THEN INSTALL SHORT BOLTS. TIGHTEN ALL BOLTS WITH THE ALLEN WRENCH.

A. 45mm Bolt x5

C. CRESCENT WASHER x5

STEP 3:

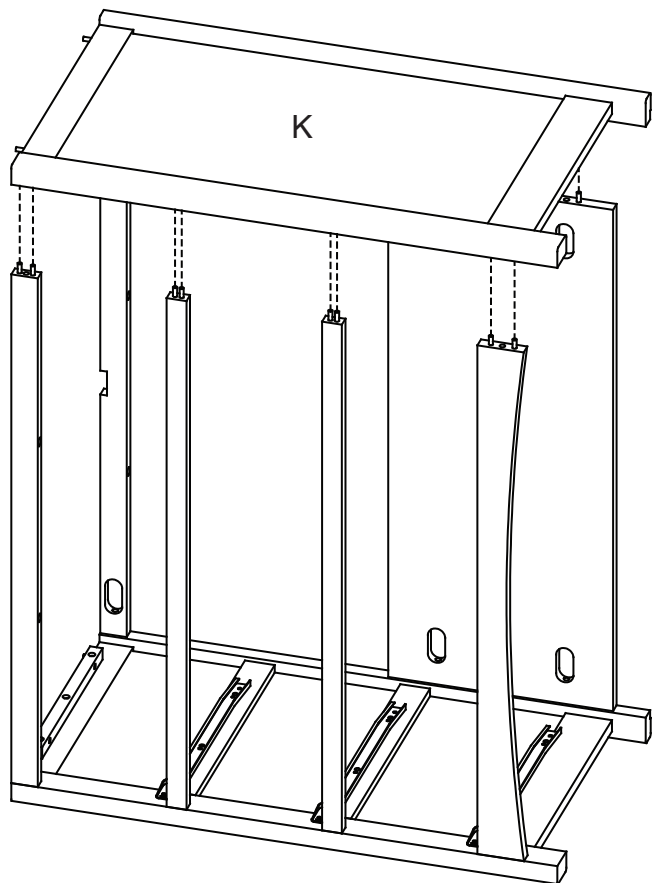

ATTACH THE RIGHT SIDE (PART K) TO THE ASSEMBLY FROM STEP 2. ENSURE ALL DOWELS ARE ALIGNED BEFORE ANY BOLTS. USING (6) BOLT (PART A) AND (6) CRESCENT WASHER (PART C). FOLLOW DIRECTION ON PAGE 4, THEN INSTALL SHORT BOLTS. TIGHTEN ALL BOLTS WITH THE ALLEN WRENCH.



A. 45mm Bolt x5

C. CRESCENT
WASHER x5



STEP 4:

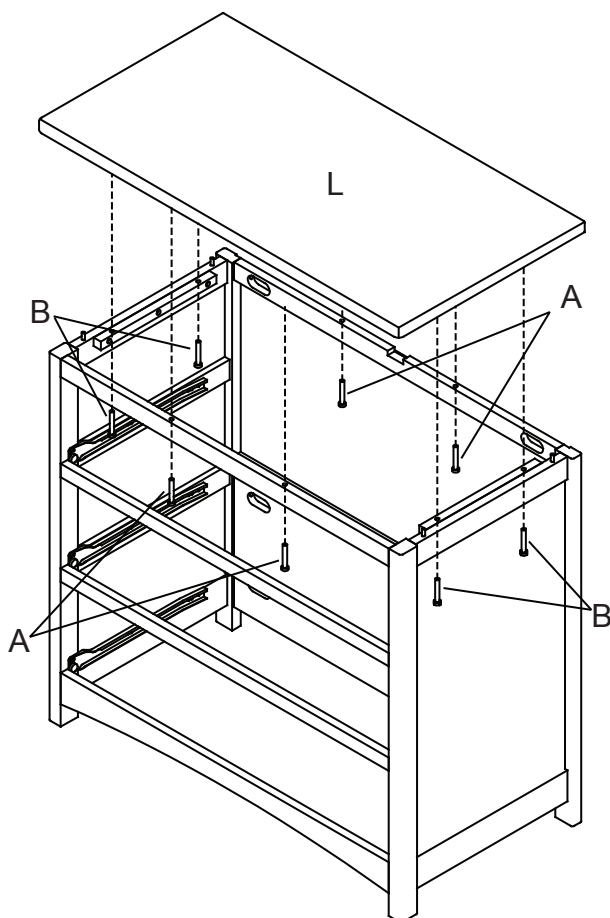

ATTACHED THE TOP PANEL (PART L) TO THE BASE OF THE CASE FROM STEP 3. ENSURE ALL DOWELS ARE ALIGNED BEFORE INSTALLING ANY BOLTS. INSTALL (4) BOLTS (PART A) THROUGH THE TOP FRONT AND BACK RAILS, THEN INSTALL (4) BOLTS (PART B) THROUGH THE SIDE. TIGHTEN ALL BOLTS WITH THE ALLEN WRENCH.



A. 45mm Bolt x4

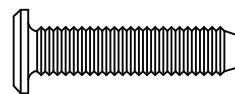

B. 28mm Bolt x4

STEP 5:

ATTACH BACK PANEL (PART U)
USING (16) SCREWS (PART F).
TIGHTEN WITH A PHILLIPS
SCREWDRIVER.

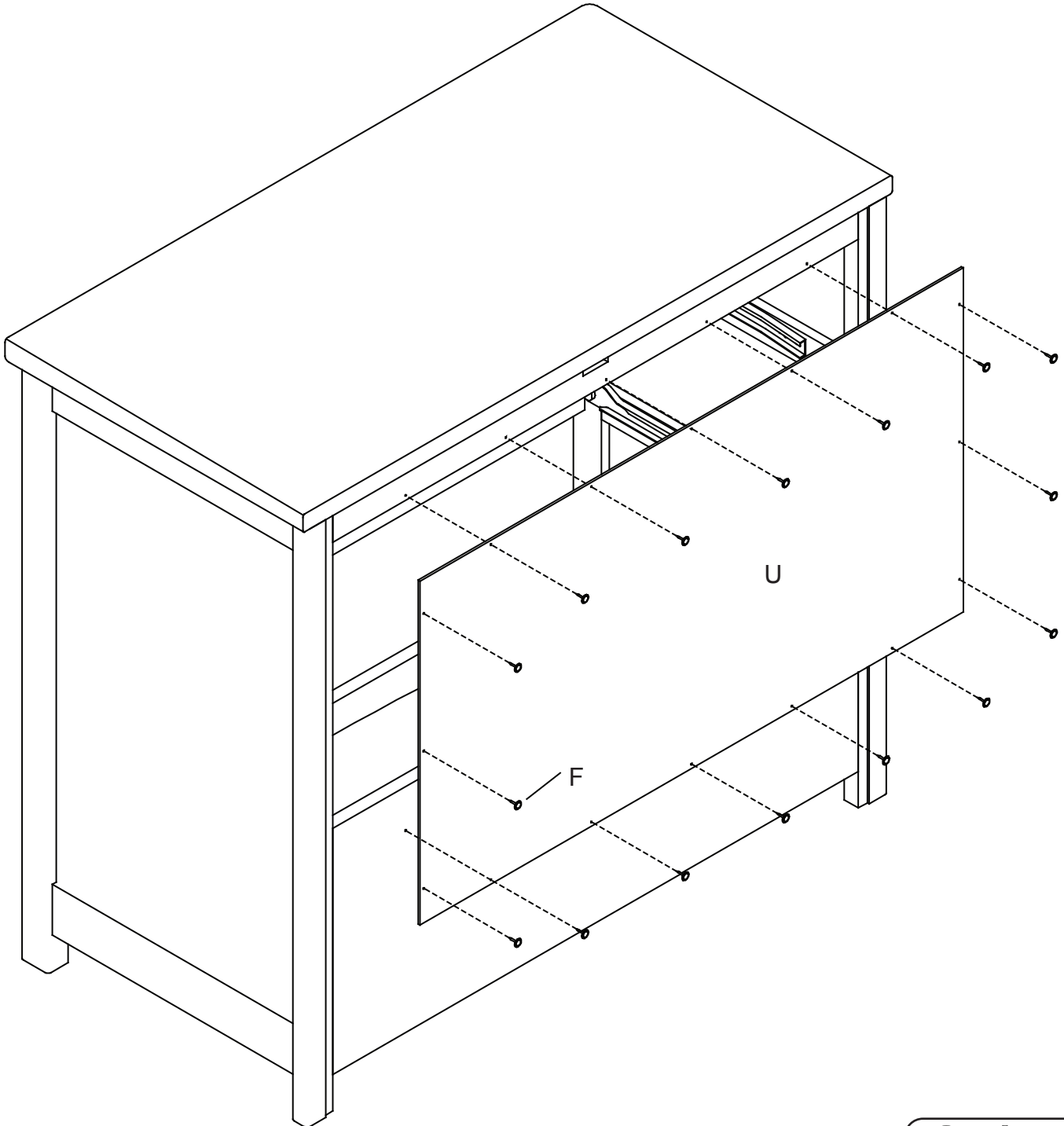

STEP 6:

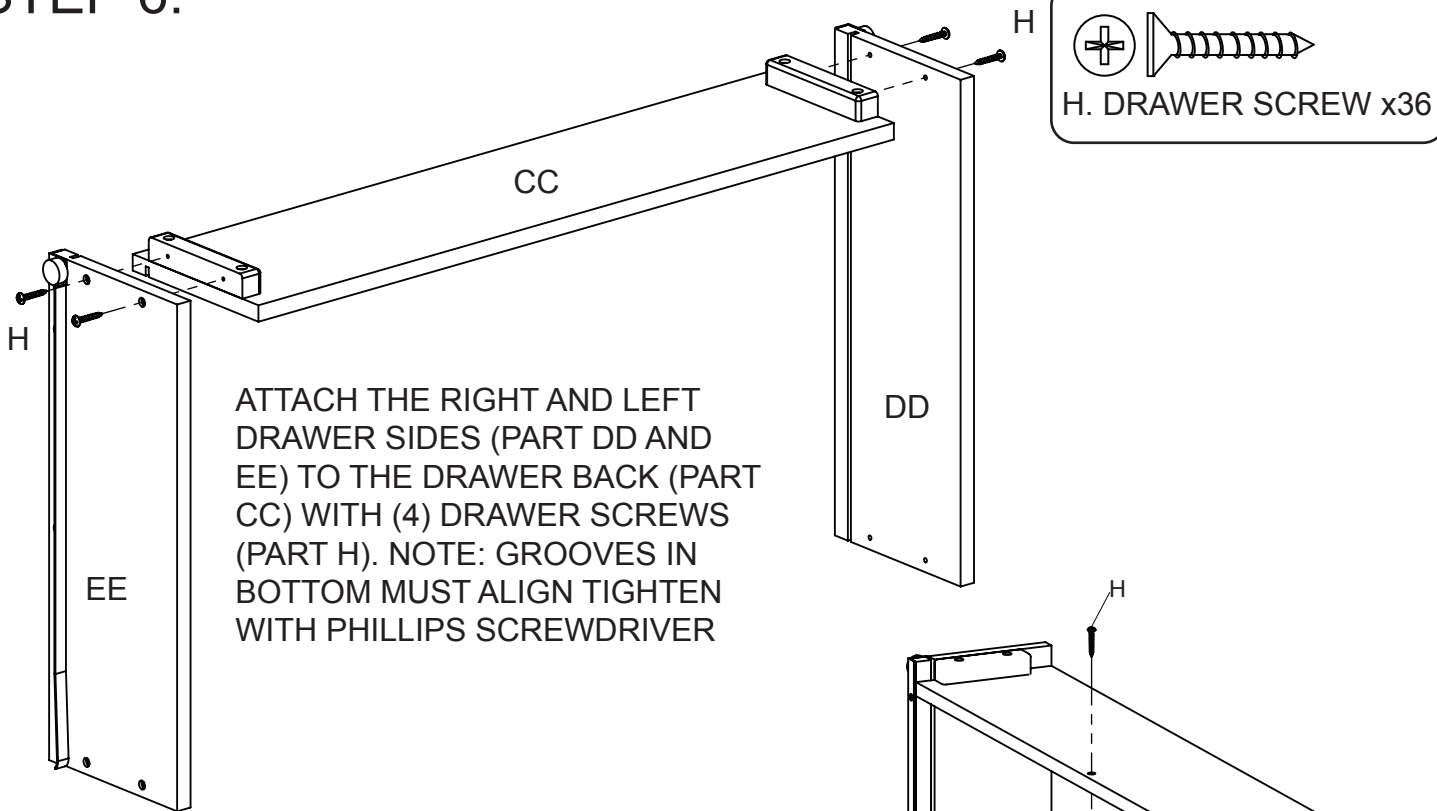

ATTACH THE RIGHT AND LEFT DRAWER SIDES (PART DD AND EE) TO THE DRAWER BACK (PART CC) WITH (4) DRAWER SCREWS (PART H). NOTE: GROOVES IN BOTTOM MUST ALIGN TIGHTEN WITH PHILLIPS SCREWDRIVER

SLIDE DRAWER BOTTOM (PART GG) INTO THE GROOVES. INSTALL THE DRAWER SUPPORT (PART FF) USING ON DRAWER SCREW (PART H)

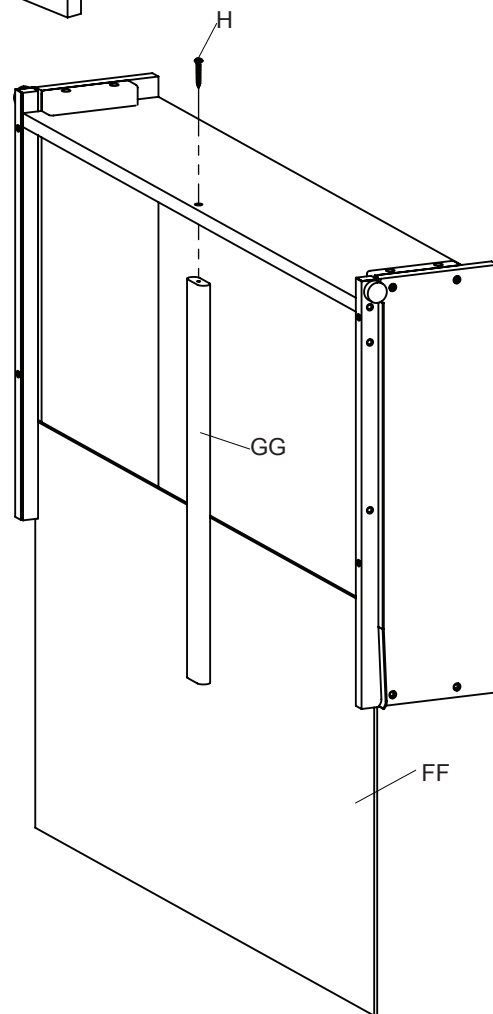

ATTACH THE DRAWER FRONT (PART AA, BB). USING (4) DRAWER SCREWS (PART H). BE SURE THE BOTTOM PANEL IS IN THE GROOVE. TIGHTEN WITH THE PHILLIPS SCREWDRIVER.

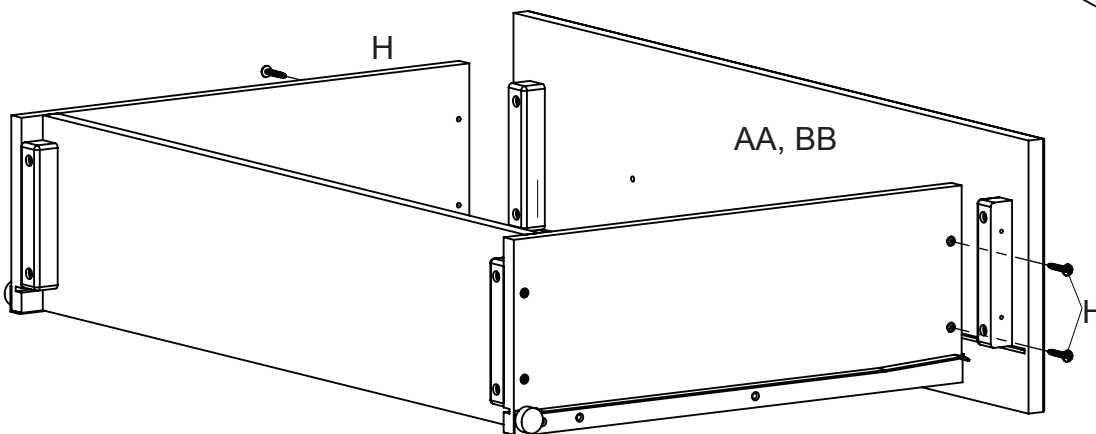

STEP 6: CONTINUED

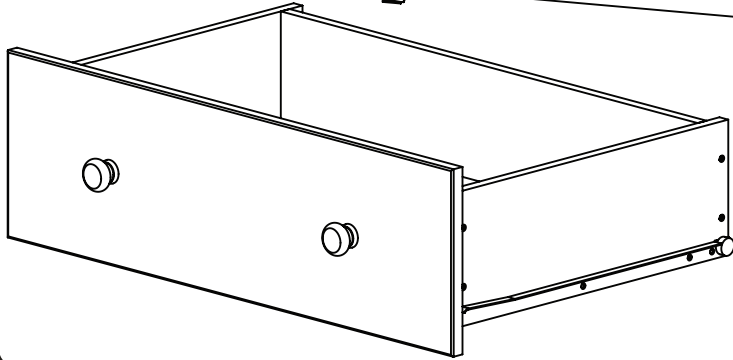
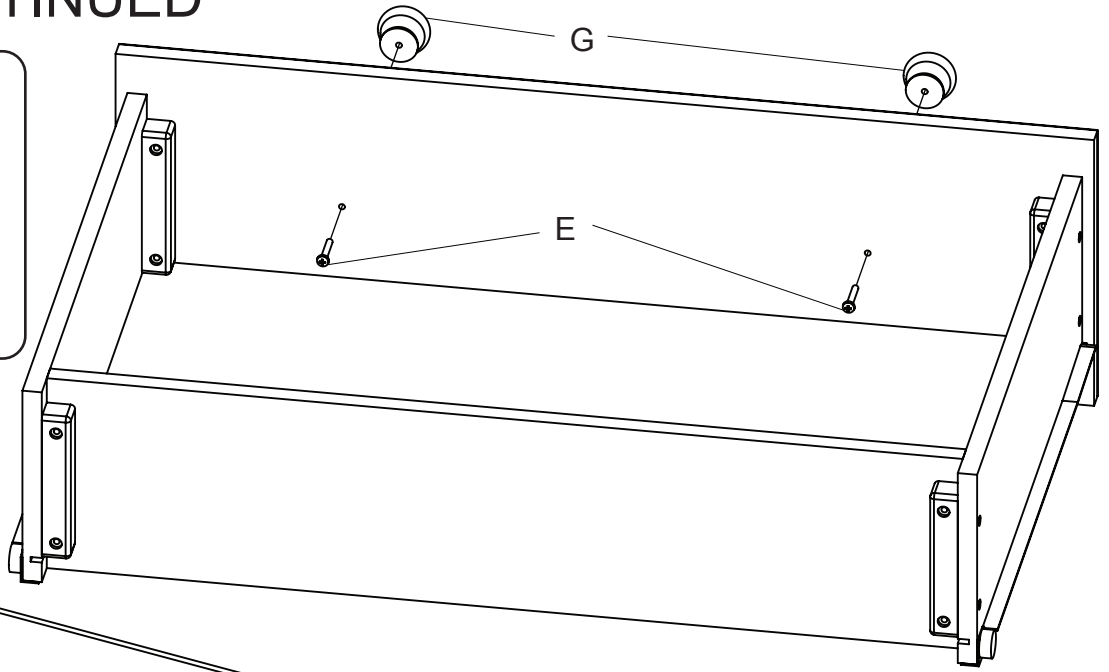
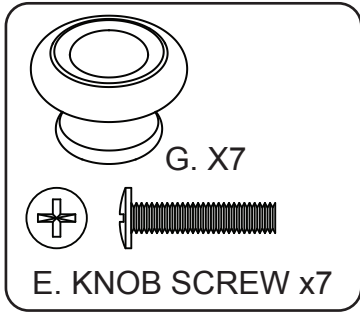

ATTACH (2) KNOBS (PART G)
WITH (2) KNOB SCREWS (PART
E). TIGHTEN WITH THE PHILLIPS

4X

STEP 8:

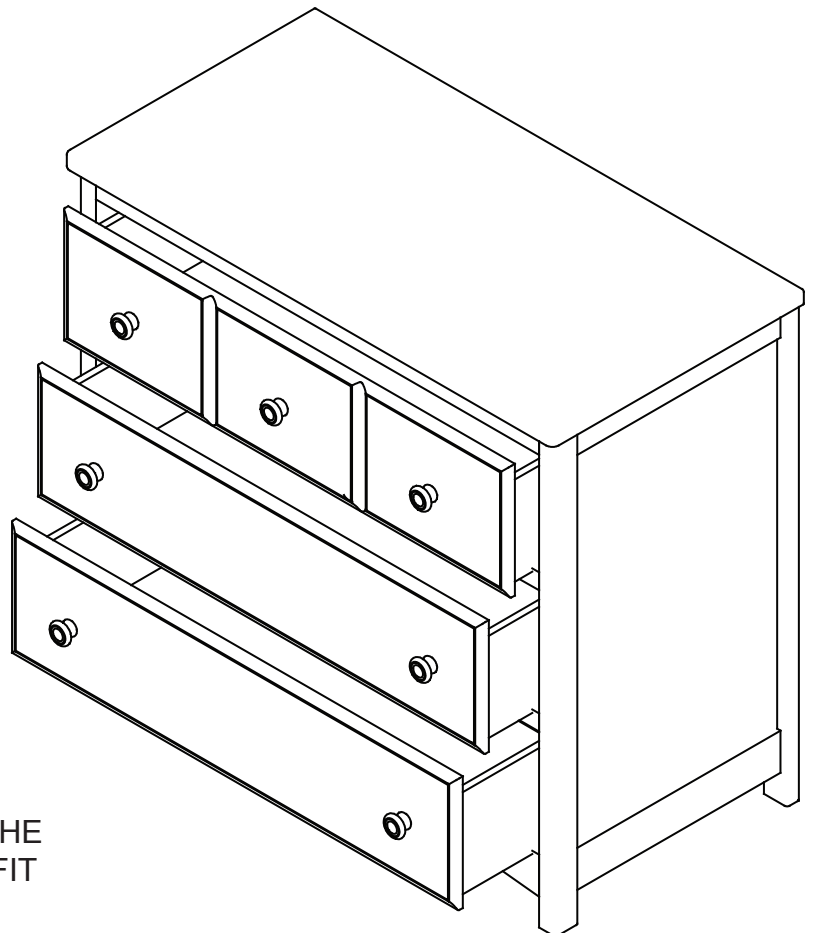

INSTALL DRAWERS. REARRANGING THE
DRAWERS MAY RESULT IN A BETTER FIT
OR ALIGNMENT.



Children's Products

Consumer Care:

www.deltachildrenproducts.com

Delta Children's Products

114 West 26th Street

New York, NY 10001

Tele.212-645-9033

Warranty: This Delta Case is warranted to be free from defects for a period of 90 days from the date of purchase under normal use. This warranty extends only to the original retail purchaser and is valid only when supplied with proof of purchase, or if received as a gift, when the registration is on file with Delta.

Please visit www.deltachildrenproducts.com and click on Product Registration to register your product for important safety alerts and updates.

For questions or comments, please log on to www.deltachildrenproducts.com and click Consumer Care, or contact us by phone at (212) 645-9033.

In the event that you need to contact our Consumer Care department please have the Style Number and Lot Number available. If they are not printed below they can be found on the label on the Back panel.

Use the space below to make note of those numbers.

STYLE No: 74103-

COLOR

REV

FACTORY

Lot No. : _____

Pack Date: _____

Date of Purchase: _____ (you should also keep your receipt)