



Read all instructions before assembly and use.
KEEP INSTRUCTIONS FOR FUTURE USE.

⚠ ADULT ASSEMBLY REQUIRED

Due to the presence of small parts during assembly, keep out of reach of children until assembly is complete.

Glider

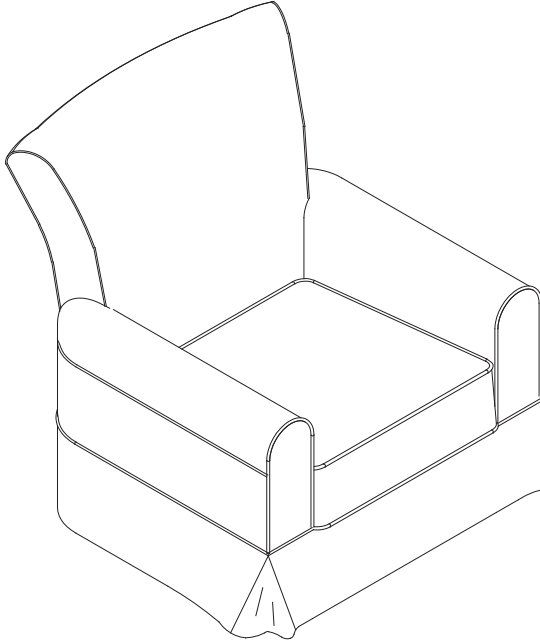

**THIS PRODUCT IS NOT INTENDED FOR
INSTITUTIONAL OR COMMERCIAL USE.**

Consumer Care:
www.DeltaChildren.com

Delta Children's Products
114 West 26th Street
New York, NY 10001
Tele.212-645-9033

Style #: _____
Lot: _____
Date: _____



When contacting Delta Consumer Care please reference the above information. Before contacting Delta Consumer Care please ensure that the information above matches the information found on the label on the bottom of Glider Seat, please reference the information found on the product when contacting Delta Consumer Care.

To register your product for important safety alerts and updates to your product please visit www.DeltaChildren.com and click on Product Registration.

FABRIC CARE INSTRUCTIONS:

- Do not use harsh or abrasive cleaners.
- Do not use bleach.
- Spot clean only with a solution of water and very small amount of a non-abrasive mild dish washing liquid.
- Apply to surface with a lint free lightly dampened soft cloth.
- Dry with a soft lint free dry cloth and Air Dry.

PARTS: MAKE SURE THAT ALL PRE-ASSEMBLED PARTS ARE TIGHT.

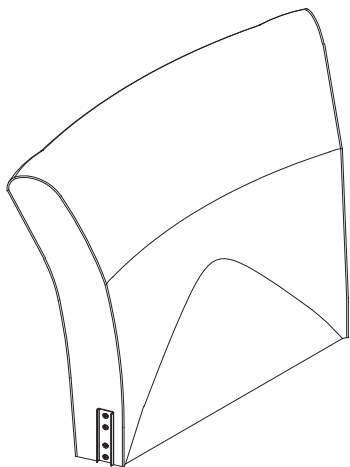

A. Seat Back x 1
Part # 25178

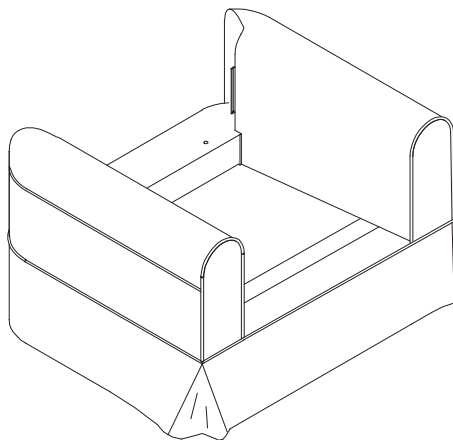

B. Seat Base x 1
Part # 25179

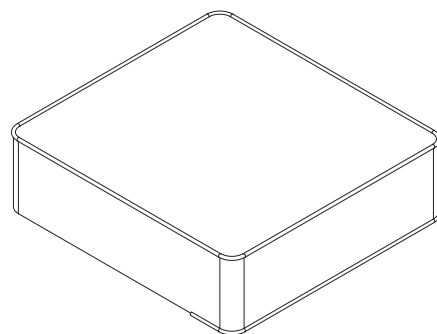

C. Seat Cushion x 1
Part # 25180

HARDWARE KIT IS PART #24593 FOR COLOR 034.
SEE FRONT COVER.

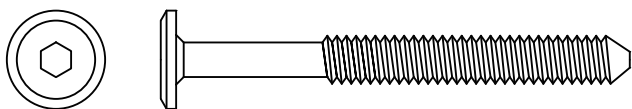

D. M6 x 60mm Bolt x 2
Part # 5469

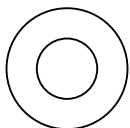

E. Φ 16mm Washer x 2
Part # 5780

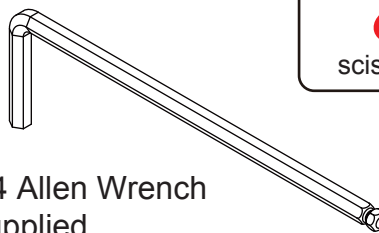

M4 Allen Wrench
Supplied
Part # 1177

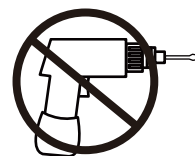

No drills necessary. Do not
use power screwdriver.

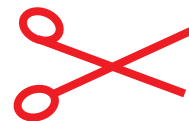

scissors (Not Provided)

Section 1: Glider Assembly

Step 2

Parts and tools required to complete step.

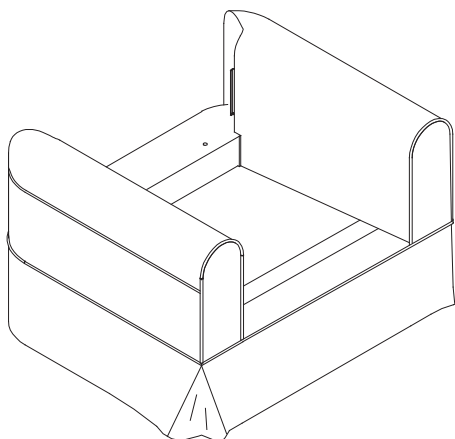

B. Seat Base x 1

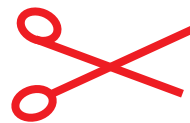

scissors (Not Provided)

From underneath the Seat Base (Part B) carefully cut the straps wrapped around the metal mechanism and the wood rail at the front and back.

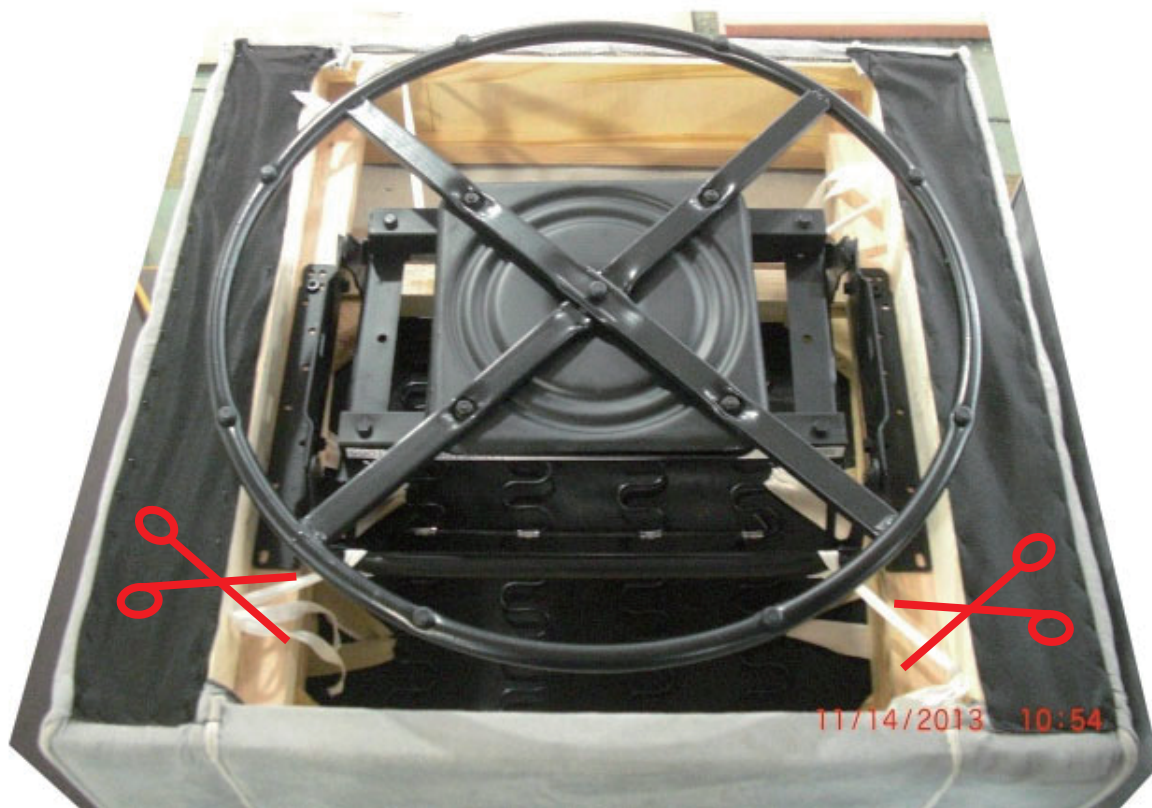

Section 1: Glider Assembly

Step 2

Parts and tools required to complete step.

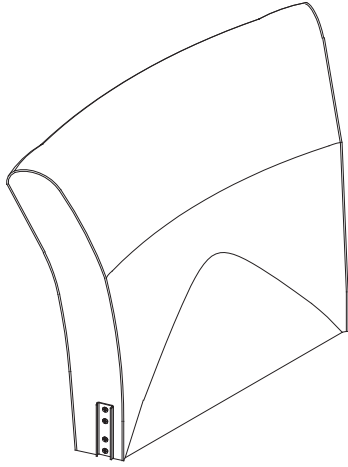

A. Seat Back x 1

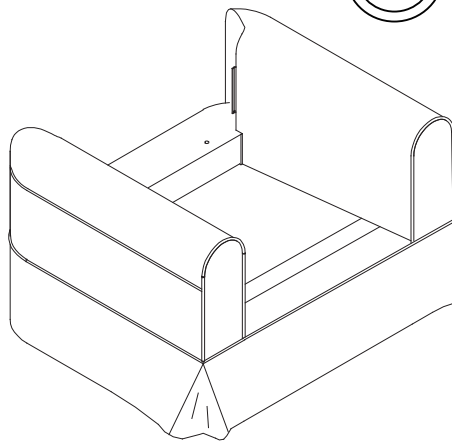

B. Seat Base x 1

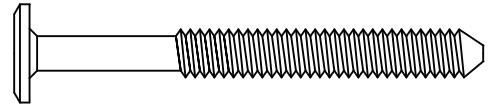
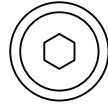

D. M6 x 60mm Bolt x 2

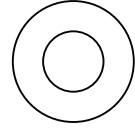

E. Φ 16mm Washer x 2

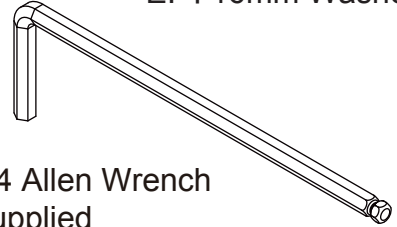

M4 Allen Wrench
Supplied

Attach the Seat Back (Part A) to the Seat Base (Part B) using (2) M6 x 60mm Bolts (Part D) and (2) Φ 16mm Washer (Part E), Tighten with the M4 Allen Wrench.

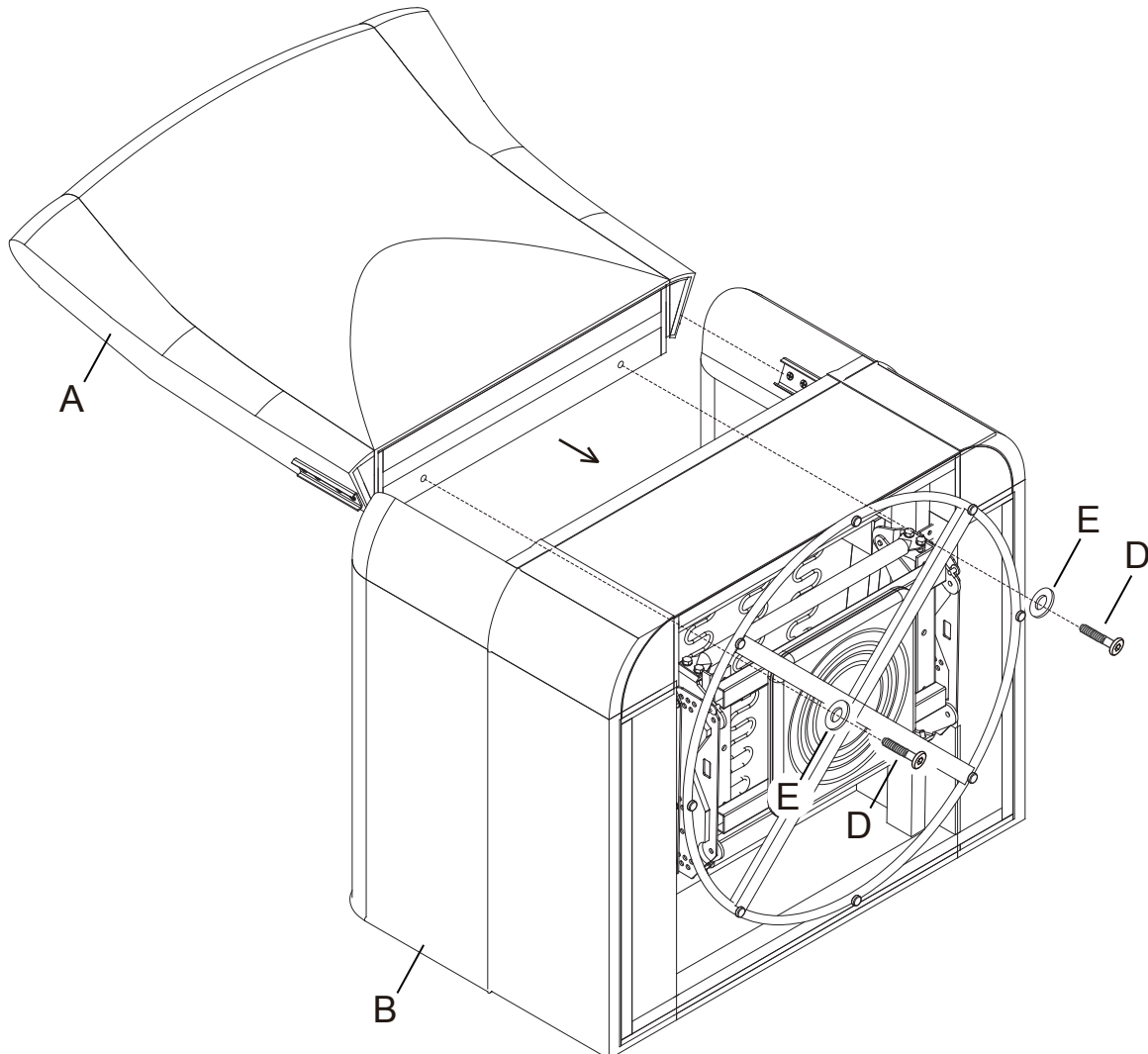

Section 1: Glider Assembly

Step 3

Parts and tools required to complete step.

From Step 2

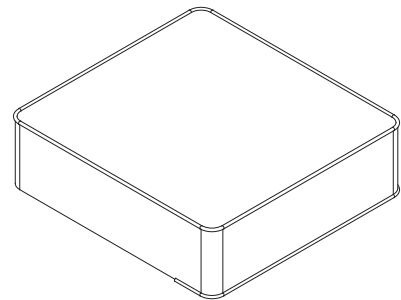
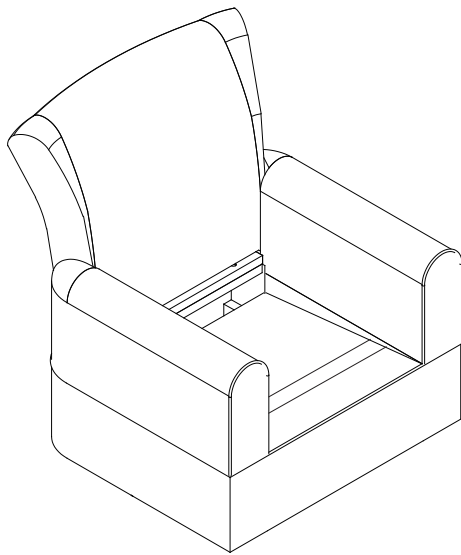

C. Seat Cushion x 1

Attach the Seat Cushion (Part C) into the Glider as shown.

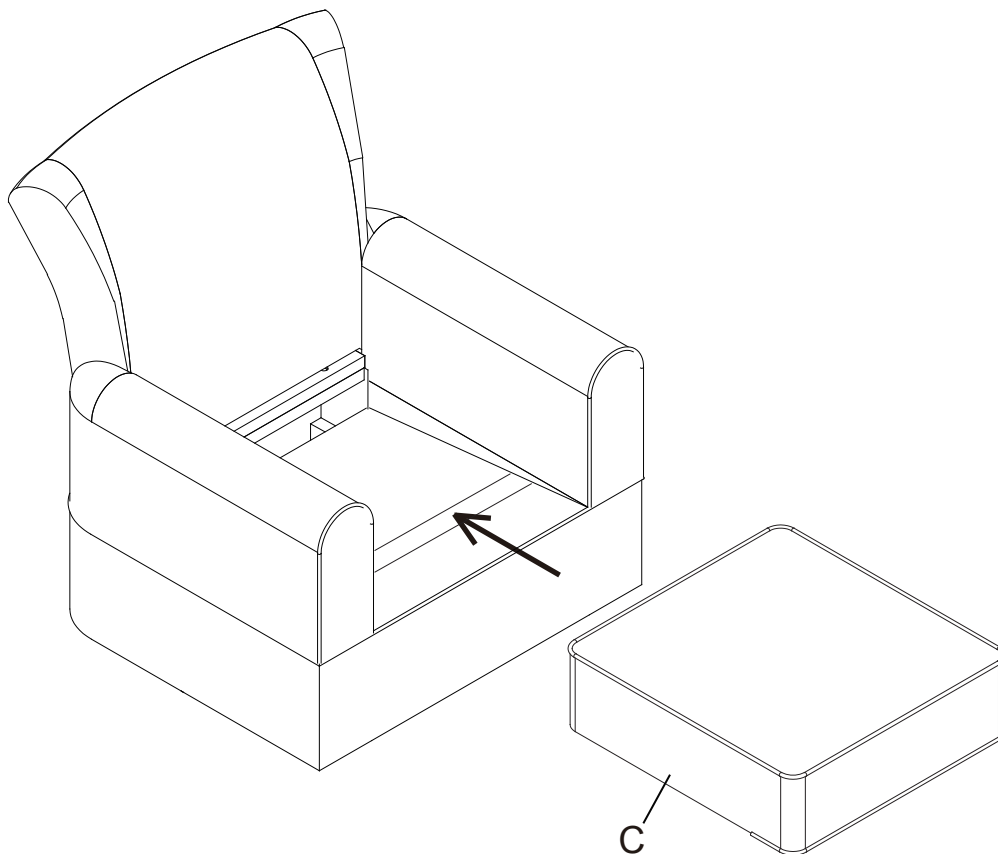



Consumer Care:
www.DeltaChildren.com
Delta Children's Products
114 West 26th Street
New York, NY 10001
Tele.212-645-9033

Warranty: This Delta product is warranted to be free from defects for a period of 90 days from the date of purchase under normal use. This warranty extends only to the original retail purchaser and is valid only when supplied with proof of purchase, or if received as a gift, when the registration is on file with Delta.

To register your product for important safety alerts and updates to your product please visit www.DeltaChildren.com

Please do not return this item to the store before contacting us about missing parts or with any questions.

To report a problem, please log on to www.DeltaChildren.com and click the Consumer Care Tab, or contact us by phone at (212) 645-9033.

In the event that you need to contact our customer service department please have the Style Number and Lot Number available. Use the space below to make note of those numbers. They can be found on the label on the bottom of Glider Seat.

STYLE No: 70967

COLOR

REV

FTY

Lot No. : _____

Pack Date: _____

Date of Purchase: _____ (you should also keep your receipt)