

READ ALL INSTRUCTIONS BEFORE
ASSEMBLY AND USE.

KEEP INSTRUCTIONS FOR FUTURE USE.

⚠ ADULT ASSEMBLY REQUIRED

DUE TO THE PRESENCE OF SMALL PARTS
DURING ASSEMBLY, KEEP OUT OF REACH OF
CHILDREN UNTIL ASSEMBLY IS COMPLETE.

www.jpma.org

**JPMA
CERTIFIED**

Conforms to
ASTM F1169 & F1821
Safety Standards

DeltaTM
Children's Products

Customer Service:

Web Site: www.deltachildrenproducts.com

Delta Children's Products

114 West 26th Street

New York, NY 10001

Tele. 212-645-9033



STYLE No: 64015

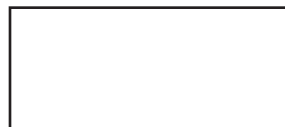

COLOR



REV



FTY

THIS PRODUCT IS NOT INTENDED FOR INSTITUTIONAL OR COMMERCIAL USE.

If you have any questions or missing parts, contact us. DO NOT return product parts to the store from where it was purchased before contacting Delta Children's Products Customer Service.

Make sure that all preassemble parts are tight. The appearance of your product may be different from that pictured in this booklet.

To register your product for important safety alerts and updates to your product please visit <http://deltaenterprise.com/register.asp>

⚠CAUTION: ANY MATTRESS USED IN THIS CRIB MUST BE AT LEAST 27 1/4 INCHES BY 51 5/8 INCHES WITH A THICKNESS NOT EXCEEDING 6 INCHES.

⚠WARNING: CRIB

Infants can suffocate on soft bedding. Never add a pillow or comforter. Never place additional padding under an infant.

Failure to follow these warnings and the assembly instructions could result in serious injury or death.

To reduce the risk of SIDS, pediatricians recommend healthy infants be placed on their backs to sleep, unless otherwise advised by your physician.

ADULT ASSEMBLY REQUIRED DUE TO SMALL PARTS.

*Read all instructions before assembling crib. **KEEP INSTRUCTIONS FOR FUTURE USE.**

***Strangulation Hazard:** STRINGS CAN CAUSE STRANGULATION! **Do not** place items with a string around a child's neck, such as hood strings or pacifier cords. **Do not** suspend strings over a crib or attach strings to toys.

***Strangulation Hazard:** To help prevent strangulation tighten all fasteners. A child can trap parts of the body or clothing on loose fasteners.

***Strangulation Hazard:** **Do not** place crib near window where cords from blinds or drapes may strangle a child.

***Fall Hazard:** When child is able to pull to a standing position, set mattress to lowest position and remove bumper pads, large toys and other objects that could serve as steps for climbing out. This crib has an adjustable mattress support. For the convenience of the parent when the baby is very small, the mattress support may be used in the highest position. Important: with the mattress support and mattress in the highest position, be absolutely sure that the top of the front crib side is at least 3 inches higher than the top surface of the mattress. If it is not, lower the mattress support and the mattress to the next highest position.

***Fall Hazard:** Stop using crib when child begins to climb out or reaches a height of 35in. (90cm), whichever occurs first. The child should be placed in a youth or regular bed.

*Check this product for damaged hardware, loose joints, missing parts or sharp edges before and after assembly and frequently during use. **Do not use crib** if any parts are missing, damaged or broken. Contact Delta Children's Products for replacement parts and instructional literature if needed. Do not substitute parts.

*Follow warnings on **all** products in a crib.

***Do not** use a water mattress with this crib.

*If refinishing, use a non-toxic finish specified for children's products.

***Never** use plastic shipping bags or other plastic film as mattress covers because they can cause suffocation.

*Infants can suffocate in gaps between crib sides and a mattress that is too small.

*Ensure a safe environment for the child by checking regularly, before placing the child in the crib, that every component is properly and securely in place.

*To avoid head injury, do not allow any child to play underneath the crib.

***Never** add an accessory such as a bassinet or changing table that extends over the sleeping area.

⚠️ WARNING: DO NOT USE THIS CRIB IF THE ENCLOSED OR ATTACHED INSTRUCTIONS CANNOT BE STRICTLY ADHERED TO. DO NOT USE THIS CRIB IF THE CHILD IS ABLE TO CLIMB OUT UNAIDED OR IS TALLER THAN 90 CM. DO NOT PLACE CORDS, STRAPS OR SIMILAR ITEMS THAT COULD BECOME WOUND AROUND THE CHILD'S NECK IN OR NEAR THIS CRIB. ENSURE THAT THE SIDES ARE PROPERLY LATCHED OR LOCKED IN PLACE WHEN THE CRIB IS OCCUPIED. THE MATTRESS USED WITH THIS CRIB SHOULD NOT BE MORE THAN 15 CM THICK AND SHOULD BE OF SUCH LENGTH AND WIDTH THAT THE GAP BETWEEN THE MATTRESS AND THE SIDES OF THE CRIB IS NOT MORE THAN 3 CM WHEN THE MATTRESS IS PUSHED INTO THE CORNER OF THE CRIB.

TODDLER BED

⚠️ WARNING ENTRAPMENT/STRANGULATION HAZARD

*INFANTS HAVE DIED IN TODDLER BEDS FROM ENTRAPMENT AND STRANGULATION. Failure to follow these warnings and the assembly instructions could result in serious injury or death.

***Never** use bed with children under 15 months.

***Never** place bed near windows where cords from blinds or drapes may strangle a child.

***Do not** place items with a string, cord, or ribbon around a child's neck, such as hood strings or pacifier cords.

***Do not** suspend strings over a toddler bed for any reason.

*The users maximum weight shall not be greater than 50 lb (22.7kg).

*The mattress intended for use on the bed shall be a full-size crib mattress having minimum dimensions of 51 5/8 in. (1310 mm) in length, 27 1/4 in. (690 mm) in width and 4 in. (100 mm) in thickness.

*Stabilizer bar must be used when converted to a toddler bed.

NOTES ON ASSEMBLY:

-During the assembly process whenever using screws or bolts, check each by placing the screw/bolt on the diagram of the item which is drawn actual size and design. Be sure to use the proper size and shape specified in the instructions.

-To assemble this unit you may be required to place the unit on it's side and face. It is strongly recommended that assembly is done on a soft, non-abrasive surface to avoid damaging the finish.

NOTES ON USE:

Keep children and others safe by following these simple rules:

- **Do not** allow any child to play on furniture
- **Do not** allow climbing on any piece of furniture.
- **Do not** allow hanging from any piece of furniture.
- Always monitor your child's activity when in the nursery.

NOTES ON CARE AND MAINTENANCE:

- **Do not** scratch or chip the finish.
- Inspect the product periodically, contact delta children's products for replacement parts or questions.
- **Do not** store the product or any parts in extreme temperatures and conditions such as a hot attic or a damp, cold basement. These extremes can cause a loss of structural integrity.
- To preserve the luster of the high quality finish on your product, it is recommended to place a doily or felt pad under any items you place on the finish.
- Clean with a damp cloth, then a dry cloth to preserve the original luster and beauty of this fine finish.
- Do not** use abrasive chemicals.
- Do not** spray cleaners directly onto furniture.
- Lift slightly when moving on carpeting to prevent leg breakage.
- Use of a vaporizer near furniture will cause wood to swell and finish to peel.

PARTS: MAKE SURE THAT ALL PRE-ASSEMBLED PARTS ARE TIGHT.

A. BACK RAIL x 1
PART # 21465

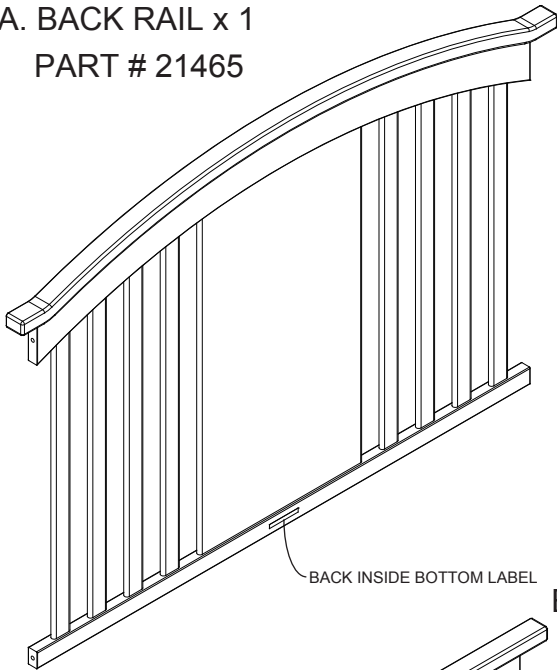

C. RIGHT REAR LEG x 1
PART # 21470



E. RIGHT FRONT LEG x 1
PART # 21472



B. LEFT REAR LEG x 1
PART # 21469



D. LEFT FRONT LEG x 1
PART # 21471



F. FRONT RAIL x 1
PART # 21466

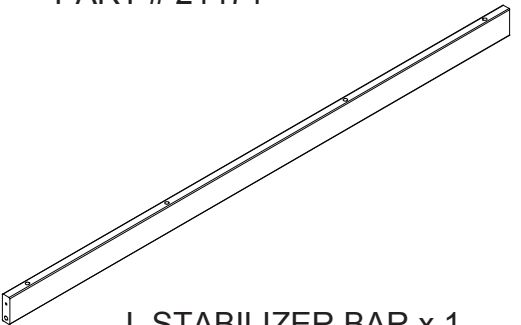
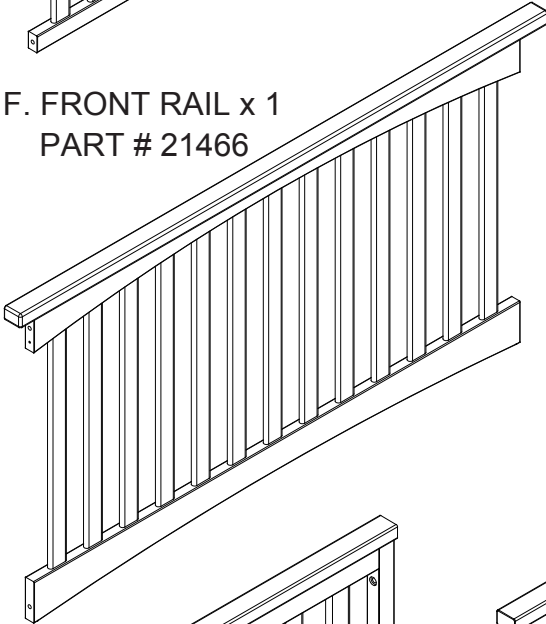

J. STABILIZER BAR x 1
PART # 21473

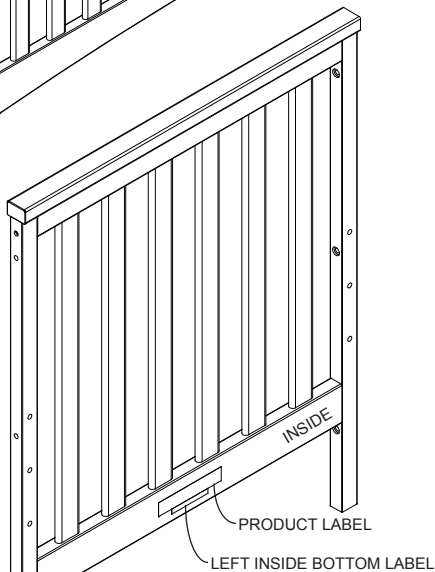

G. LEFT CRIB END x 1
PART # 21467

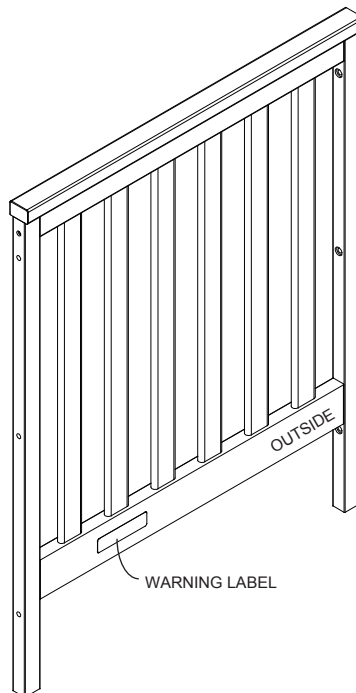

H. RIGHT CRIB END x 1
PART # 21468

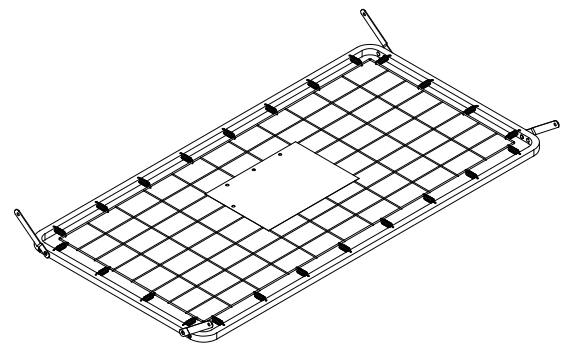

K. MATTRESS SUPPORT x 1
PART # 16945

POUCH ATTACHED TO MATTRESS SUPPORT - KEEP INSTRUCTIONS IN THIS POUCH AFTER ASSEMBLY. WARNINGS RELATED TO THE SAFE USE OF THIS CRIB ARE PRINTED ON THE POUCH.

PARTS: HARDWARE KIT IS PART # 21475 FOR COLOR 145 OR #21476 FOR COLOR 205.
SEE FRONT COVER.

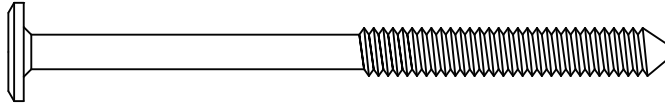
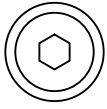

L. M6 x 85 mm BOLT x 6

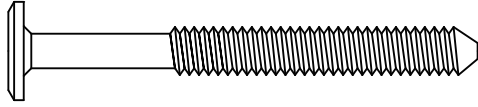
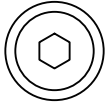

M. M6 x 60 mm BOLT x 4

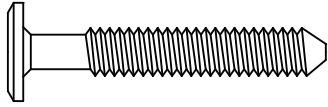
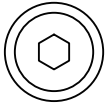

N. M6 x 40 mm BOLT x 12

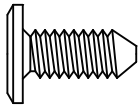
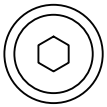

P. M6x15 mm BOLT x 8

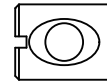

R. BARREL NUT x 6



S. Φ 4x30 mm METAL PIN x 4



M4 ALLEN WRENCH SUPPLIED

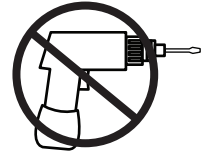

Flat Head
Screwdriver
(not supplied)

SECTION 1: CRIB ASSEMBLY

STEP 1

PARTS AND TOOLS REQUIRED TO COMPLETE STEP

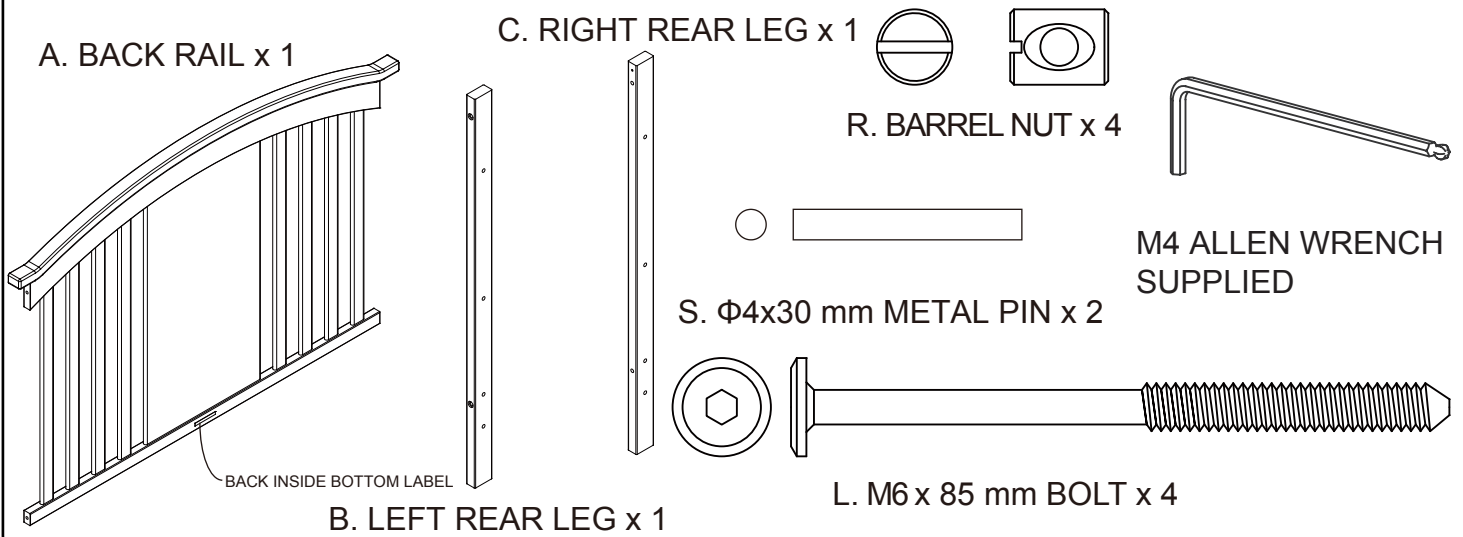

ATTACH (1) BACK RAIL (PART A) TO (1) LEFT REAR LEG (PART B) AND (1) RIGHT REAR LEG (PART C) USING (2) $\Phi 4 \times 30$ mm METAL PINS (PART S), (4) M6x85mm BOLTS (PART L) AND (4) BARREL NUTS (PART R). TIGHTEN WITH THE M4 ALLEN WRENCH. USE THE FLAT HEAD SCREWDRIVER TO HOLD THE BARREL NUT IN THE PROPER ALIGNMENT.

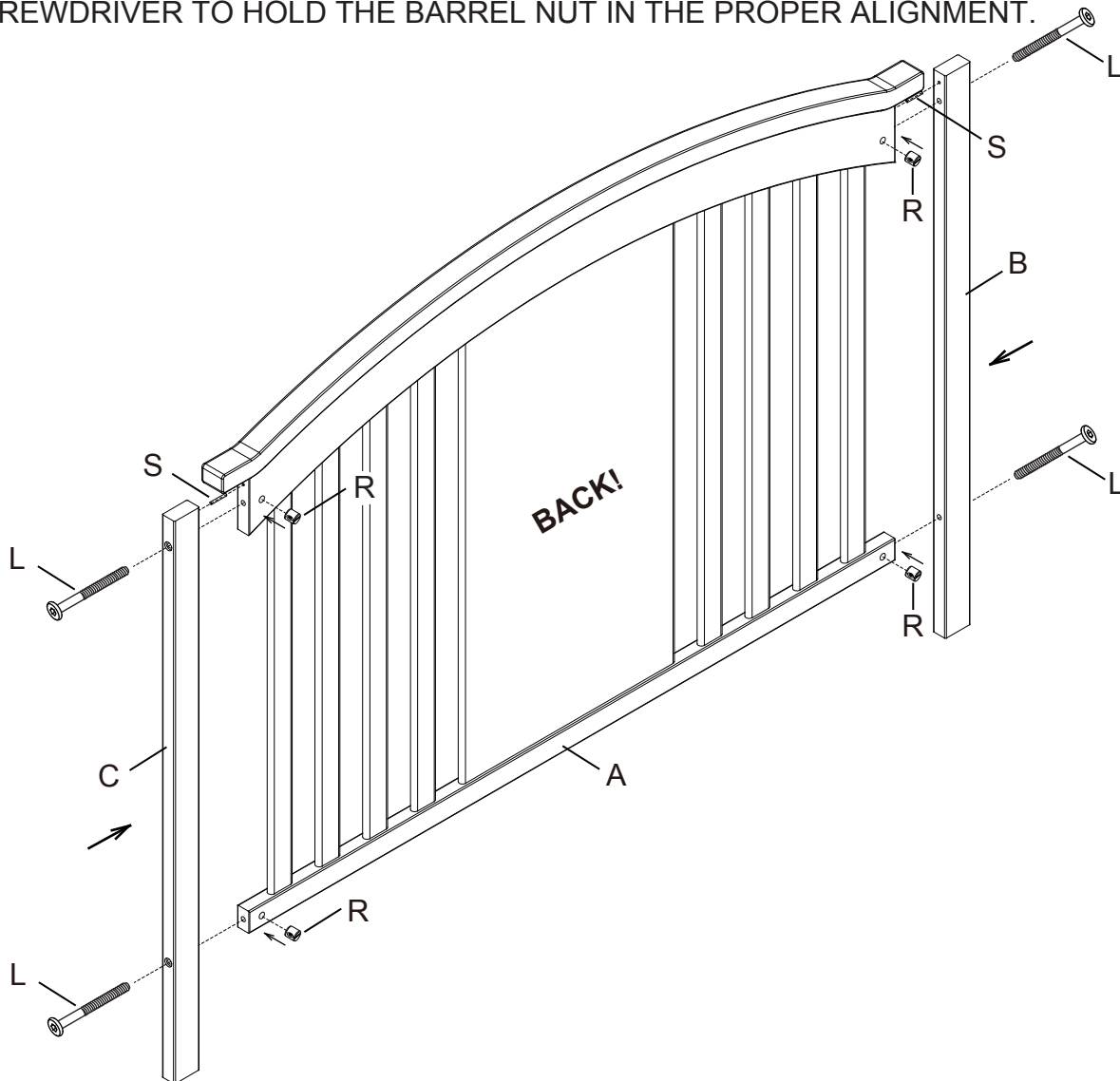

SECTION 1: CRIB ASSEMBLY

STEP 2

PARTS AND TOOLS REQUIRED TO COMPLETE STEP

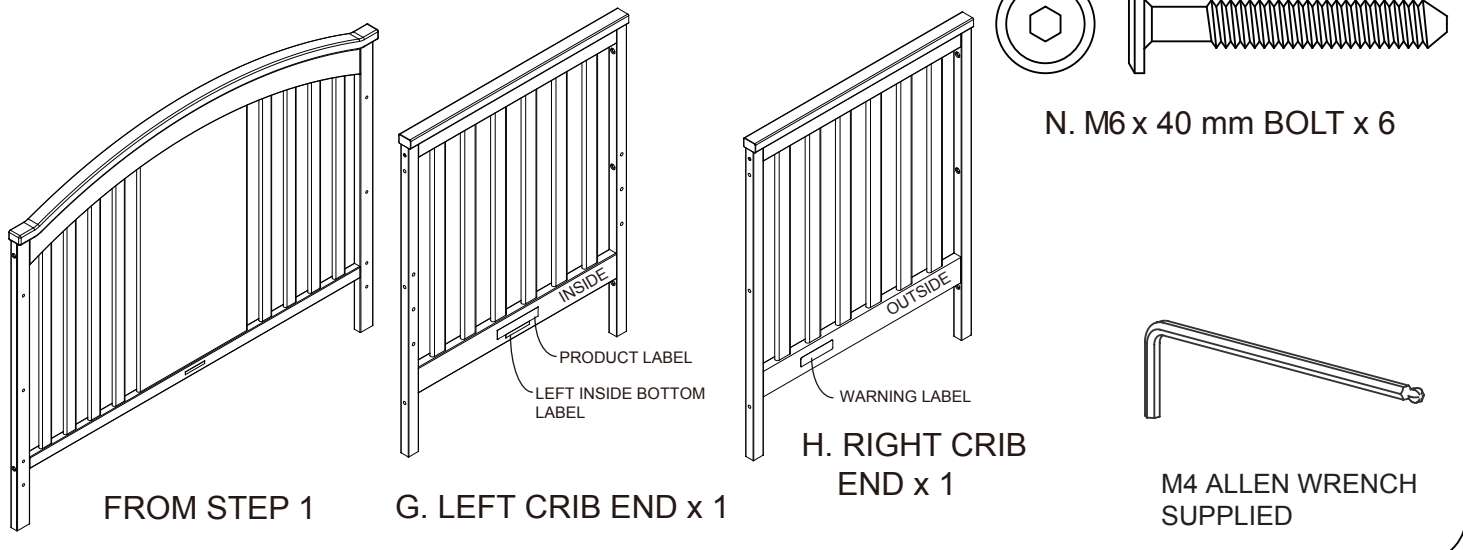

ATTACH (1) LEFT CRIB END (PART G) AND (1) RIGHT CRIB END (PART H) TO THE ASSEMBLY FROM STEP 1 USING (6) M6x40 mm BOLTS (PART N). TIGHTEN WITH THE M4 ALLEN WRENCH.

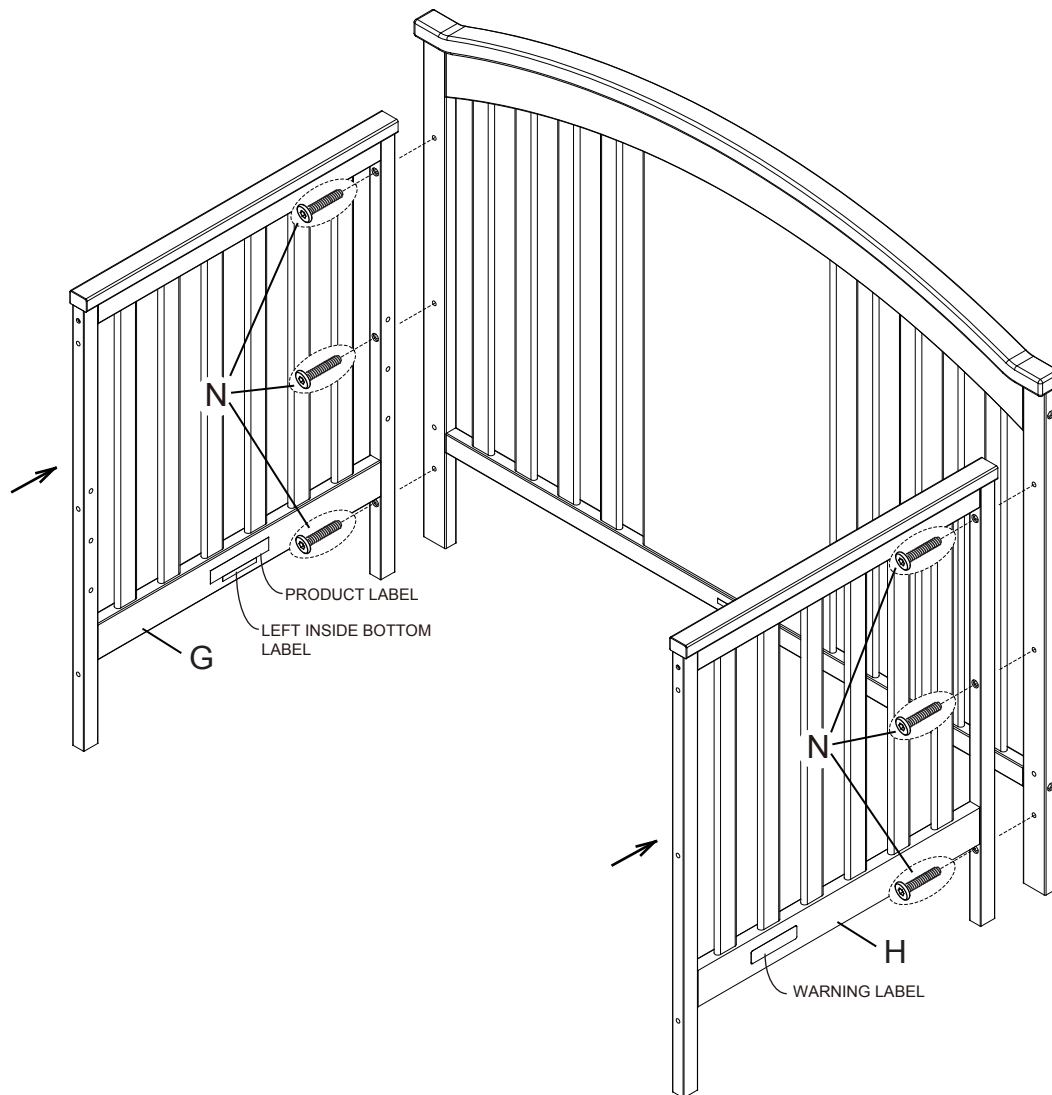

SECTION 1: CRIB ASSEMBLY

STEP 3

PARTS AND TOOLS REQUIRED TO COMPLETE STEP

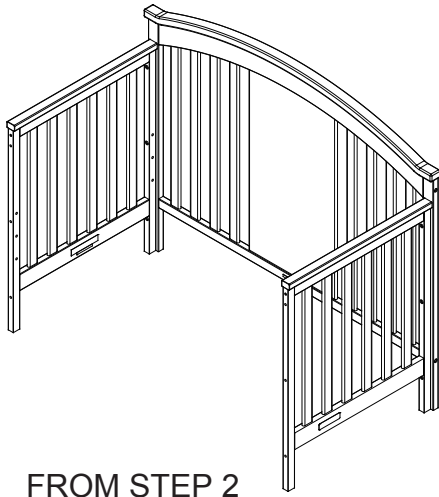

M4 ALLEN WRENCH
SUPPLIED

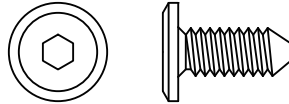

P. M6x15 mm BOLT x 4

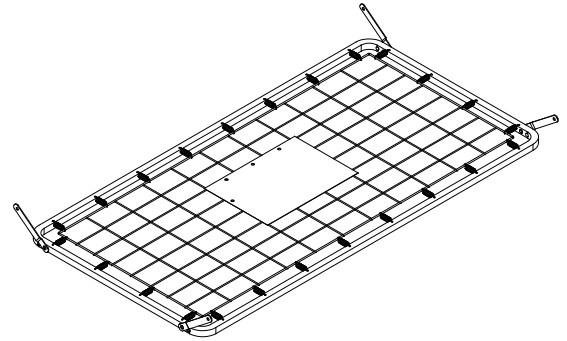

K. MATTRESS SUPPORT x 1

ATTACH THE MATTRESS SUPPORT (PART K) IN ALL CORNERS USING (1) M6x15 mm BOLT (PART P) IN EACH CORNER. TIGHTEN WITH THE M4 ALLEN WRENCH.

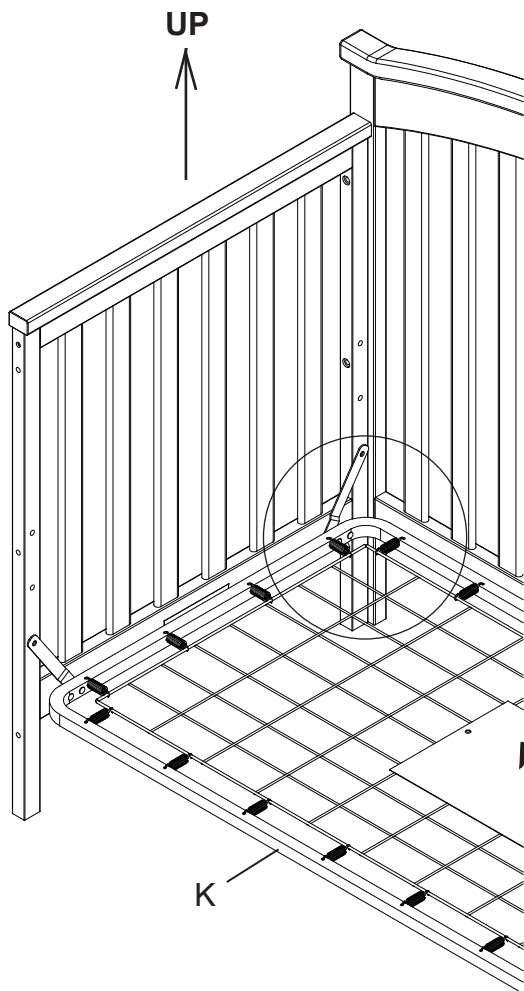

THE ⚠ WARNINGS PRINTED ON THE POUCH ATTACHED TO THE MATTRESS SUPPORT MUST FACE UP, THE SPRINGS MUST FACE UP.

THIS CRIB HAS (3) ADJUSTMENT POSITIONS, USE THE HIGHEST ONLY FOR NEW BORN, MOVE THE MATTRESS DOWN AS THE CHILD GROWS.

⚠ WARNING:

FALL HAZARD: WHEN CHILD IS ABLE TO PULL TO A STANDING POSITION, SET MATTRESS TO LOWEST POSITION AND REMOVE BUMPER PADS, LARGE TOYS AND OTHER OBJECTS THAT COULD SERVE AS STEPS FOR CLIMBING OUT.

⚠ WARNINGS ON POUCH MUST FACE UP.

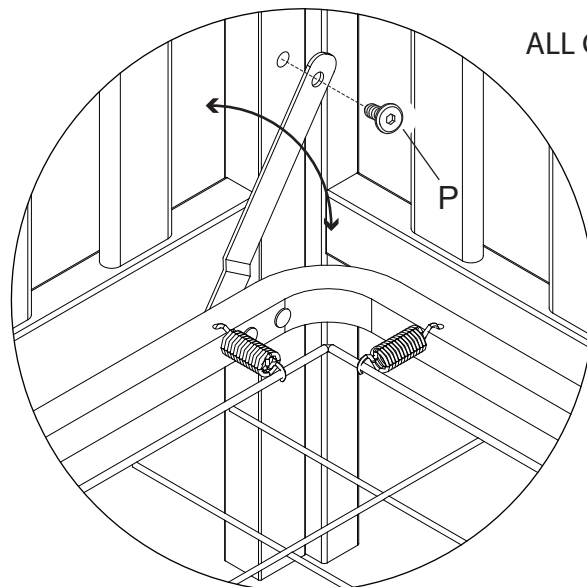

SECTION 1: CRIB ASSEMBLY

STEP 4

PARTS AND TOOLS REQUIRED TO COMPLETE STEP

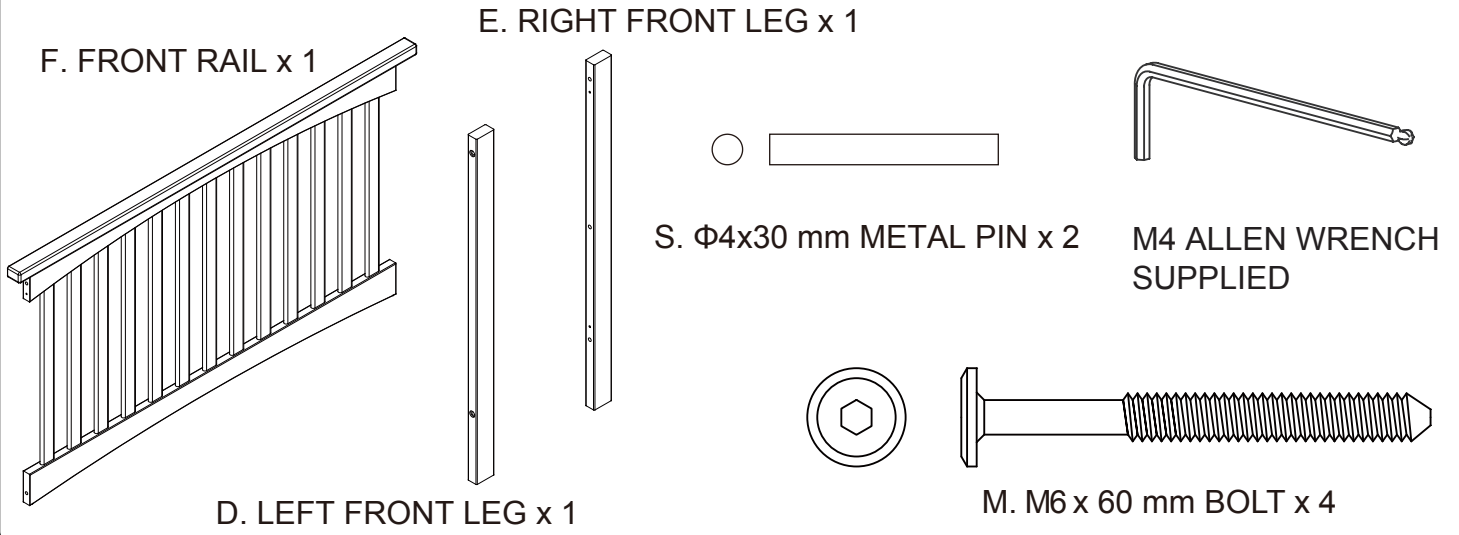

ATTACH (1) FRONT RAIL (PART F) TO (1) LEFT FRONT LEG (PART D) AND (1) RIGHT FRONT LEG (PART E) USING (2) $\Phi 4 \times 30$ mm METAL PINS (PART S), (4) M6x60mm BOLTS (PART M). TIGHTEN WITH THE M4 ALLEN WRENCH.

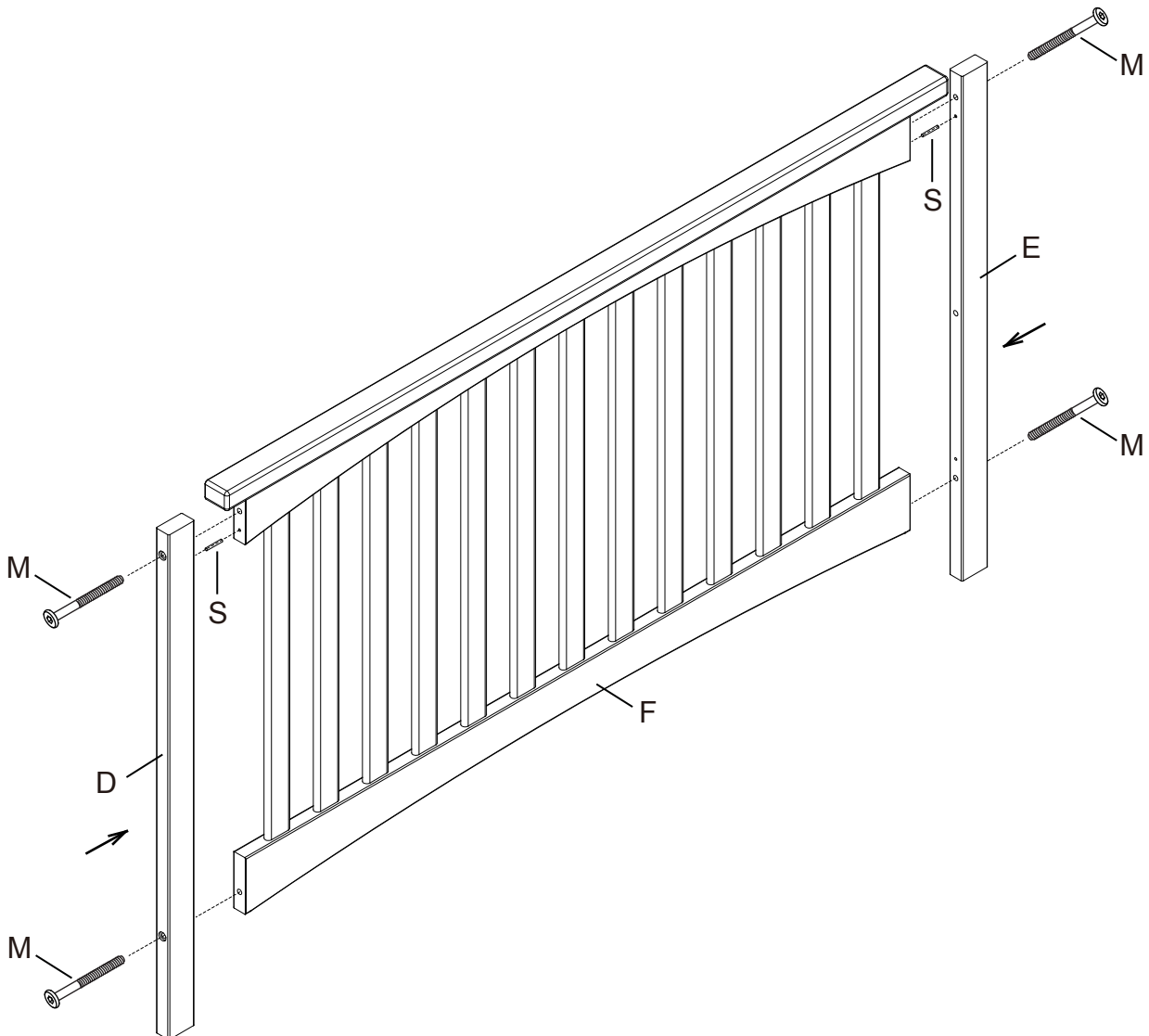

SECTION 1: CRIB ASSEMBLY

STEP 5

PARTS AND TOOLS REQUIRED TO COMPLETE STEP

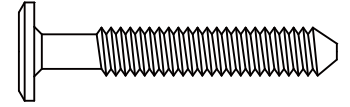
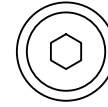
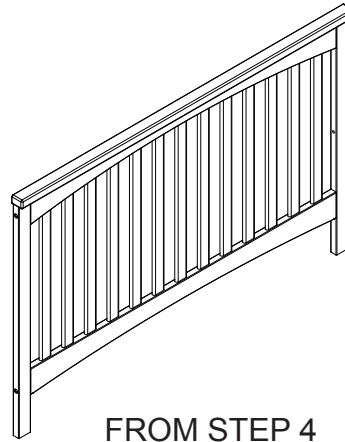
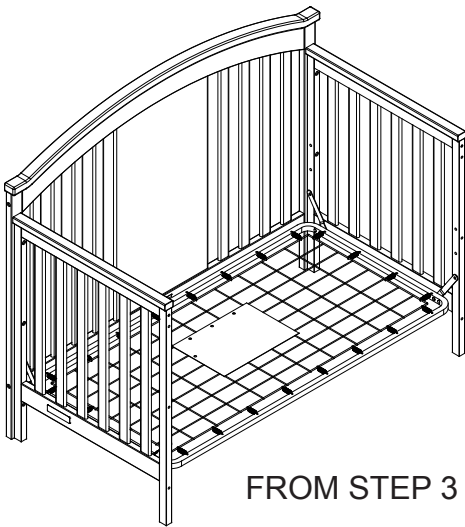

N. M6 x 40 mm BOLT x 6



M4 ALLEN WRENCH
SUPPLIED

ATTACH THE ASSEMBLY FROM STEP 4 TO THE ASSEMBLY FROM STEP 3 USING (6) M6x40 mm BOLTS (PART N). TIGHTEN WITH THE M4 ALLEN WRENCH.

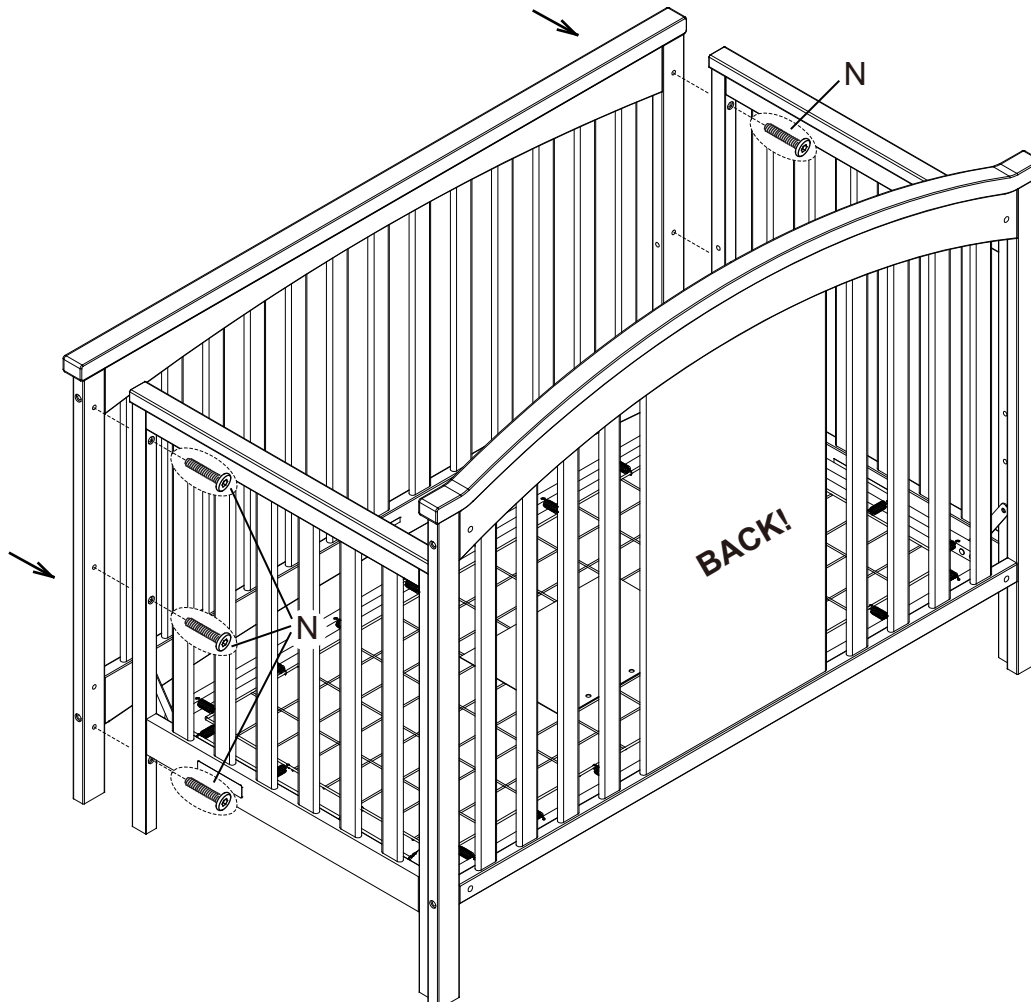

SECTION 1: CRIB ASSEMBLY

STEP 6

PARTS AND TOOLS REQUIRED TO COMPLETE STEP



ASSEMBLY INSTRUCTION
BOOKLET

STORE THE ASSEMBLY INSTRUCTION BOOKLET IN THE POUCH ATTACHED TO THE MATTRESS SUPPORT. STORE ALL PARTS AND TOOLS SEPARATELY, IN A SAFE PLACE.

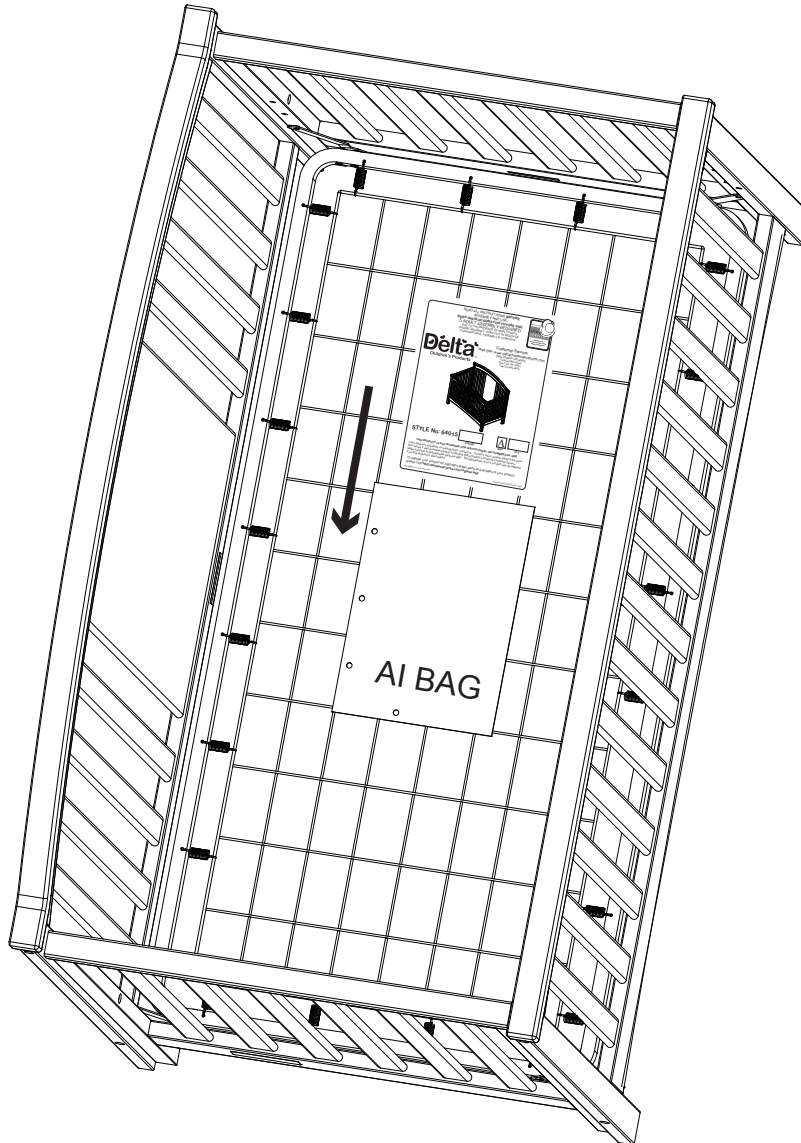

⚠ WARNING: SEE PAGE 2 FOR INFORMATION

SECTION 2: TODDLER BED CONVERSION

STEP 1

PARTS AND TOOLS REQUIRED TO COMPLETE STEP



FINISHED CRIB



M4 ALLEN WRENCH
SUPPLIED

REMOVE THE FRONT RAIL INSTALLED IN STEP 4 OF SECTION 1 CRIB ASSEMBLY.

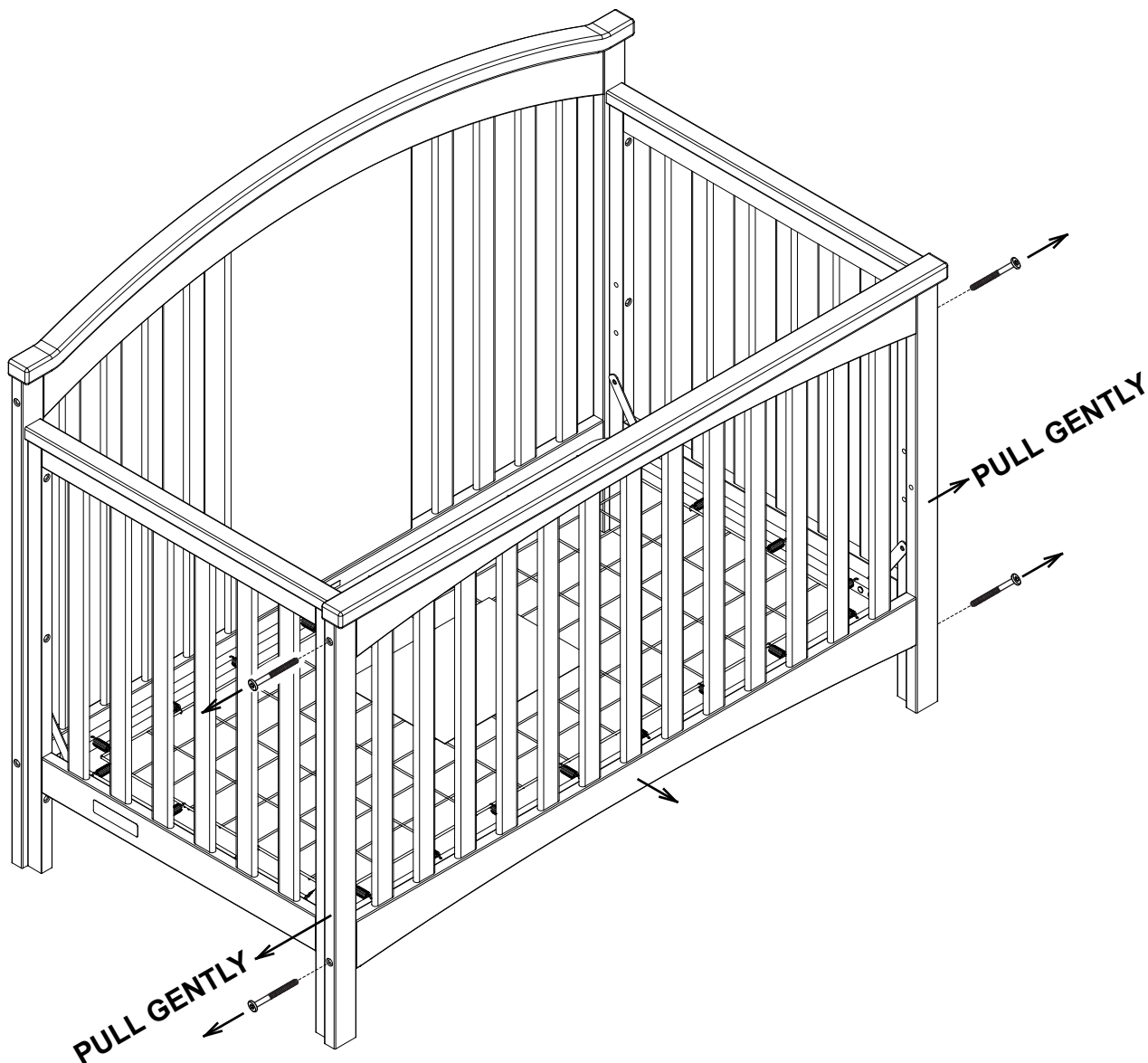

SECTION 2: TODDLER BED CONVERSION

STEP 2

PARTS AND TOOLS REQUIRED TO COMPLETE STEP



J. STABILIZER
BAR x 1

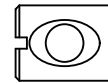
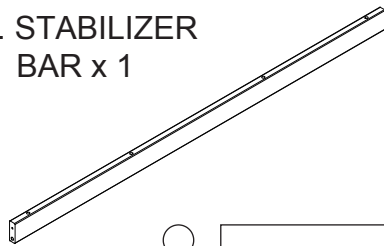

R. BARREL NUT x 2

S. Φ 4x30 mm METAL PIN x 2



M4 ALLEN WRENCH
SUPPLIED

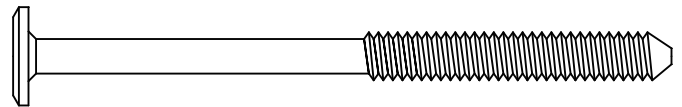
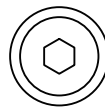

L. M6 x 85 mm BOLT x 2

ATTACH THE STABILIZER BAR (PART J) TO THE ASSEMBLY FROM STEP 1 USING (2) Φ 4x30 mm METAL PINS (PART S), (2) M6x85 mm BOLTS (PART L) AND (2) BARREL NUTS (PART R). TIGHTEN WITH THE M4 ALLEN WRENCH. USE THE FLAT HEAD SCREWDRIVER TO HOLD THE BARREL NUT IN THE PROPER ALIGNMENT.

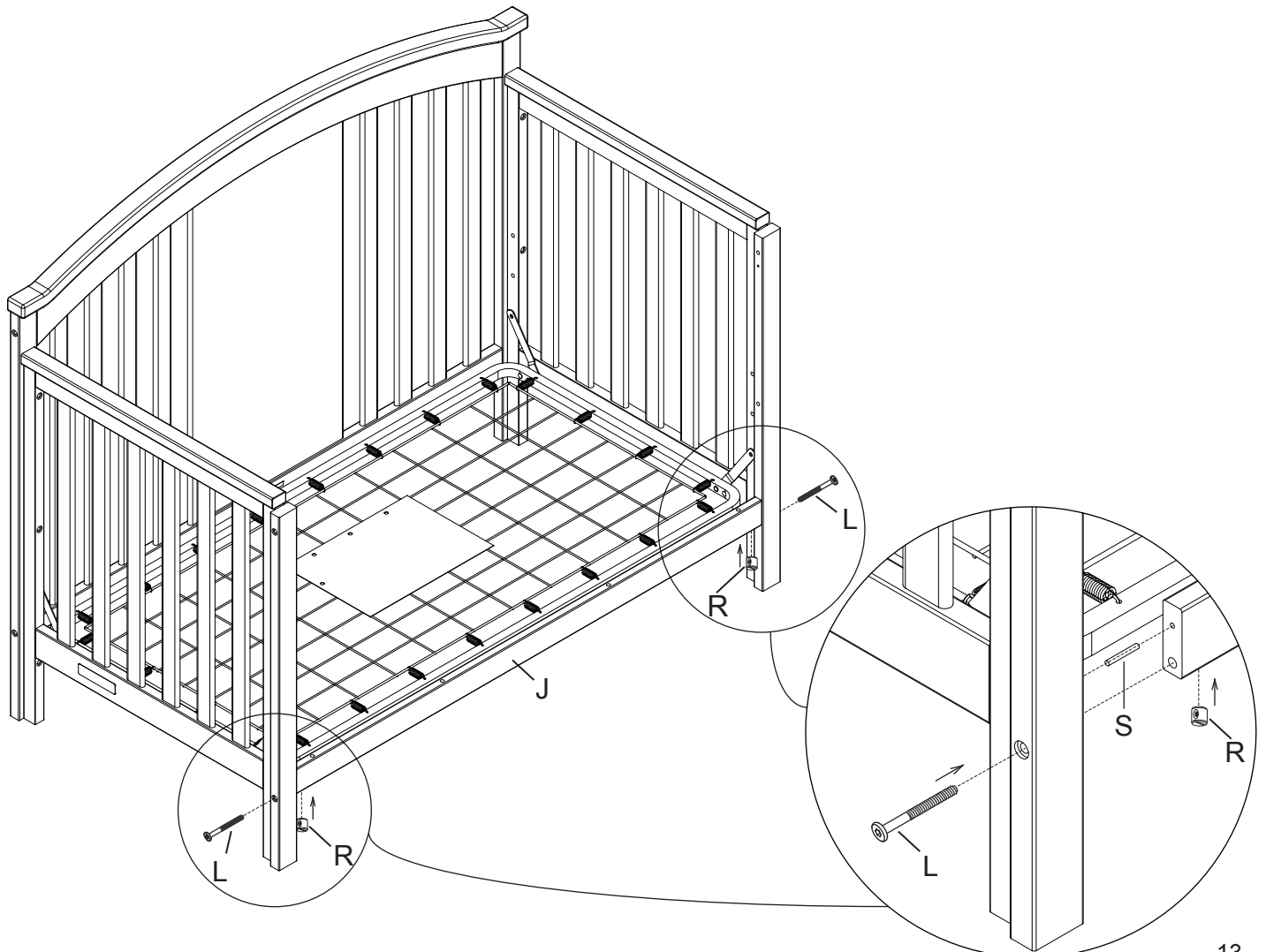

SECTION 2: TODDLER BED CONVERSION STEP 3

⚠ WARNING: SEE PAGE 3 FOR TODDLER BED WARNINGS

THE MATTRESS SUPPORT MUST BE IN THE LOWEST POSITION.
STORE ALL HARDWARE SAFELY.
READ ALL WARNINGS ON PAGE 3

AS SHOWN, USE AS A DAY BED OR LOVE SEAT SOFA.
DO NOT USE WITHOUT STABILIZER BAR INSTALLED.

⚠ STABILIZER BAR MUST BE USED
WHEN CONVERTED TO A TODDLER BED.

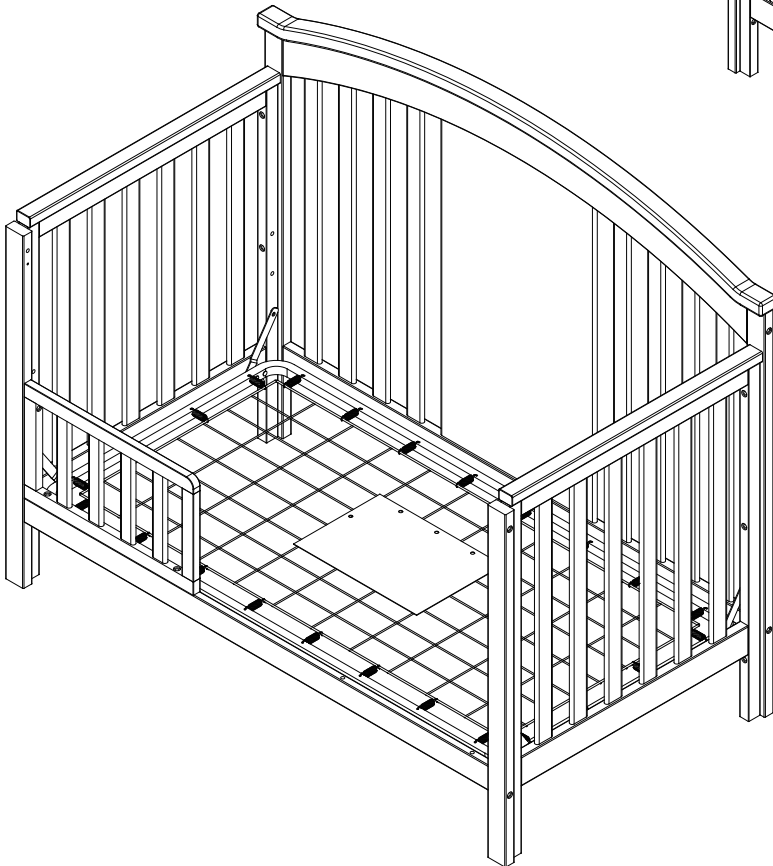
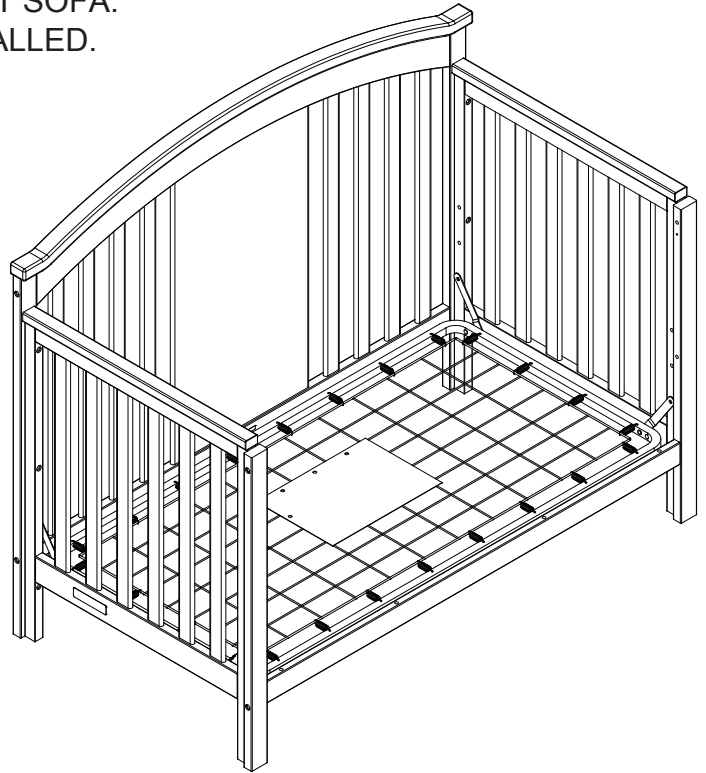

A TODDLER BED GUARDRAIL IS
AVAILABLE FOR THIS CRIB.
PLEASE SEE YOUR CRIB RETAILER, VISIT
WWW.DELTACHILDRENSPRODUCTS.COM
OR CONTACT DELTA CONSUMER CARE
FOR MORE INFORMATION.
THIS CRIB USES DELTA STYLE # 0080
GUARDRAIL.

SECTION 3: FULL SIZE BED CONVERSION

STEP 1

PARTS AND TOOLS REQUIRED TO COMPLETE STEP



M4 ALLEN WRENCH
SUPPLIED

YOU HAVE THE OPTION TO CONVERT THE CRIB TO A FULL SIZE BED. SIMPLY FOLLOW STEPS IN REVERSE ORDER TO DISASSEMBLE THE CRIB. THE HEAD BOARD IS THE BACK RAIL ASSEMBLY DONE THROUGH STEP 1 OF SECTION 1. TO CREATE THE FOOTBOARD, ASSEMBLE THE LEFT FRONT LEG (PART D), RIGHT FRONT LEG (PART E) AND FRONT RAIL (PART F) USING (2) $\Phi 4 \times 30$ mm METAL PINS (PART S) AND (4) M6x60mm BOLTS (PART M) AS SHOWN. STORE ALL PARTS AND HARDWARE IN A SAFE PLACE.

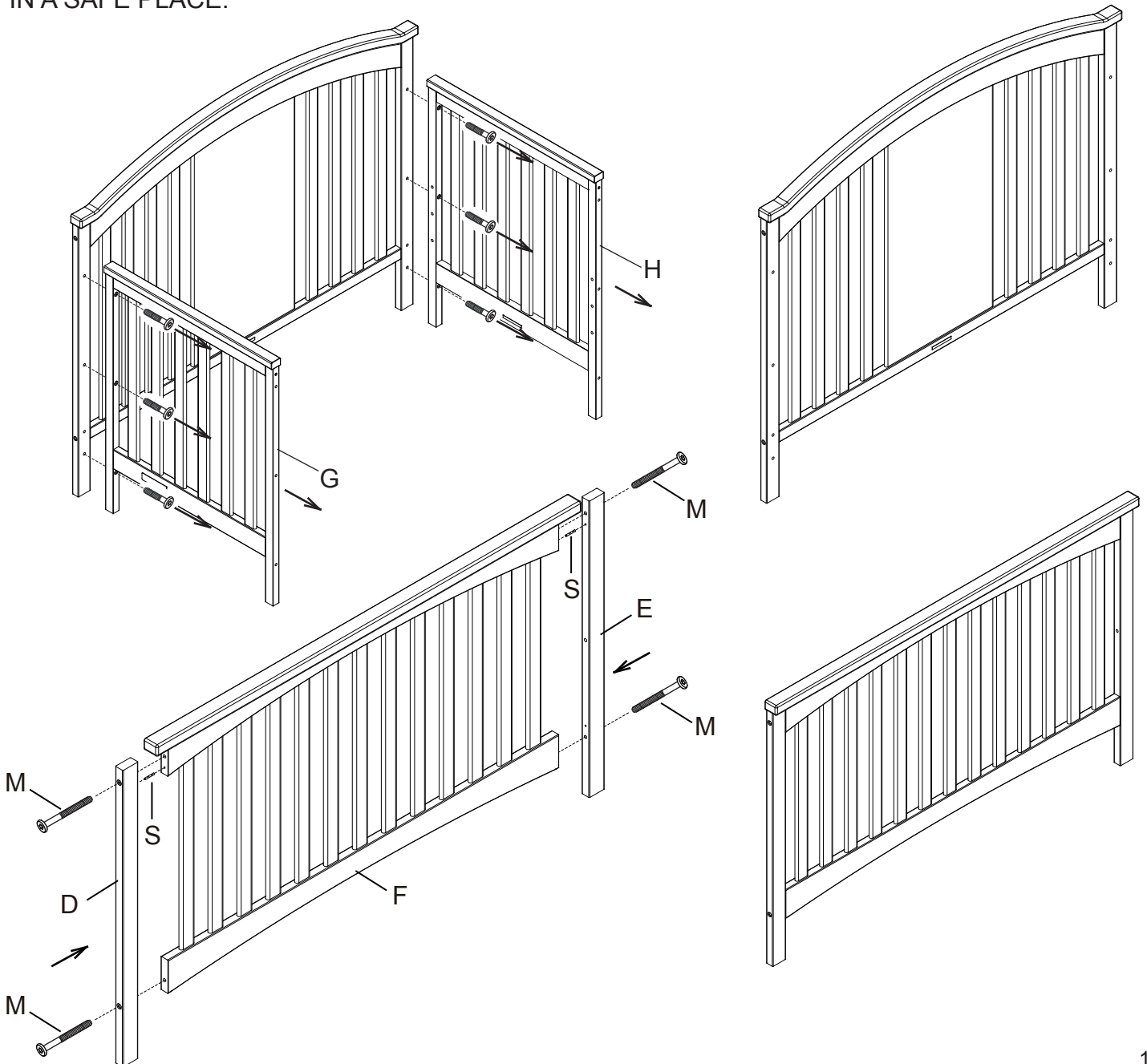

SECTION 3: FULL SIZE BED CONVERSION STEP 2

PARTS AND TOOLS REQUIRED TO COMPLETE STEP

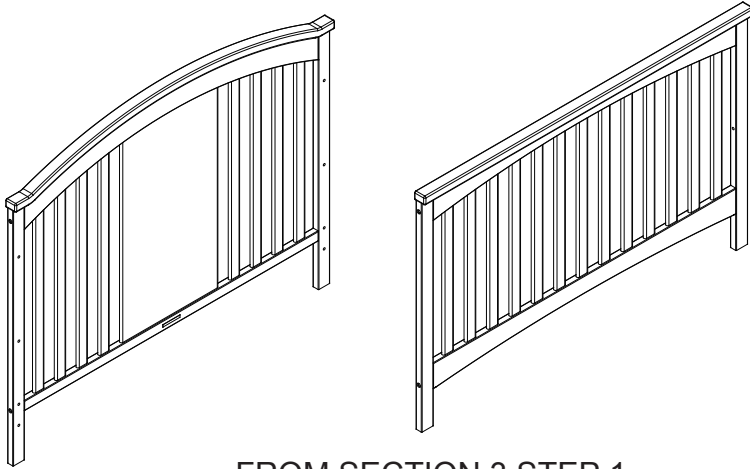

FROM SECTION 3 STEP 1

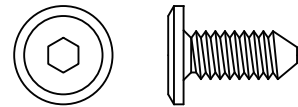

P. M6x15 mm BOLT x 8



M4 ALLEN WRENCH
SUPPLIED

ATTACH BED FRAME TO THE HEADBOARD (FROM SECTION 3 STEP 1) AND FOOTBOARD (FROM SECTION 3 STEP 1) USING (8) M6x15mm BOLTS (PART P). FOLLOW ALL INSTRUCTIONS SUPPLIED WITH THE BEDFRAME. **NOTE:** BED FRAME SYSTEM IS NOT INCLUDED, SEE YOUR FURNITURE OR MATTRESS RETAILER. CONTACT DELTA CHILDREN'S PRODUCTS FOR INFORMATION OR WITH QUESTIONS.

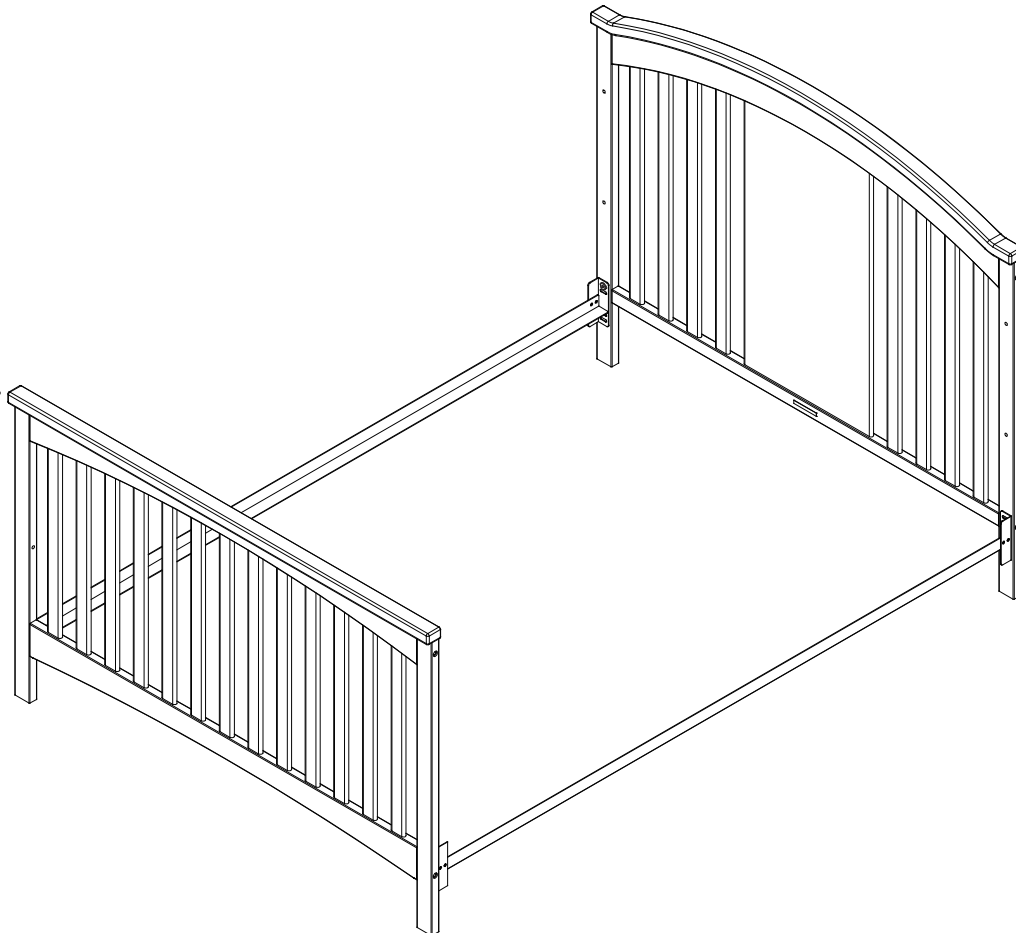

NOTE: SHOWN AS A FULL SIZE HEADBOARD AND FOOTBOARD, NOT ALL BED FRAME SYSTEMS ALLOW USE OF A FOOTBOARD.



Children's Products

Customer Service:

Web Site: www.deltachildrenproducts.com

Delta Children's Products

114 West 26th Street

New York, NY 10001

Tele.212-645-9033

Warranty: This Delta Crib is warranted to be free from defects for a period of 1 year from the date of purchase under normal use. This warranty extends only to the original retail purchaser and is valid only when supplied with proof of purchase, or if received as a gift, when the registration is on file with Delta.

To register your product for important safety alerts and updates to your product please visit <http://deltaenterprise.com/register.asp>

Please do not return this item to the store before contacting us about missing parts or with any questions.

To report a problem, please log on to www.deltachildrenproducts.com and click the Customer Service Tab, log on to www.deltaenterprise.com/customer_service.asp, or contact us by phone at (212) 645-9033.

In the event that you need to contact our customer service department please have the Style Number and Lot Number available. Use the space below to make note of those numbers. They can be found on the label on the Crib End bottom rail.

Style No.: _____

Lot No. : _____

Pack Date: _____

Date of Purchase: _____ (you should also keep your receipt)