

STEP #2
ÉTAPE N°2
PASO #2

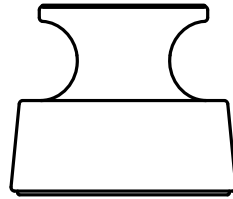

KK1. Knob x 6
bouton
pomo

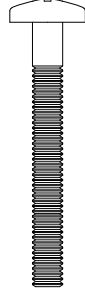

KK2. Knob screw x 6
vis de bouton
tornillo para pomos

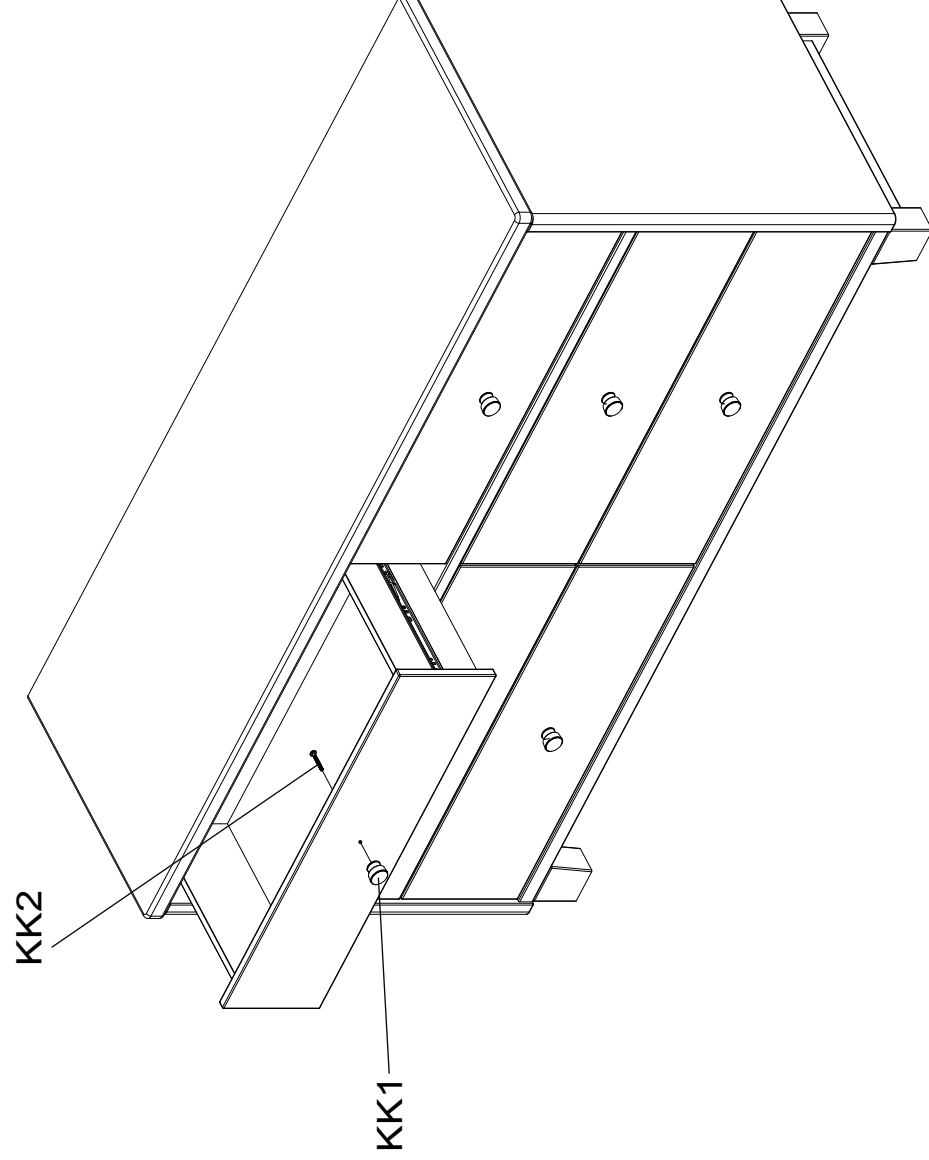

Attach (1) Knob (Part KK1) to each drawer using (1) Knob Screw (Part KK2), tighten with the Phillips Screwdriver.

Fixez (1) bouton (Pièce KK1) sur chaque tiroir à l'aide de (1) vis de bouton (Pièce KK2). Serrez à l'aide d'un tournevis Phillips.

Fije (1) pomo (Pieza KK1) a cada gaveta utilizando (1) tornillo para pomos (Pieza KK2). Apriete utilizando un destornillador Phillips.

How To Operate The Drawer Glide Comment faire fonctionner le tiroir Glide Como la función de deslizamiento del cajón

Right Side Push Lever Down
Droit levier poussoir Side Down
Presione lado de la palanca derecha hacia abajo

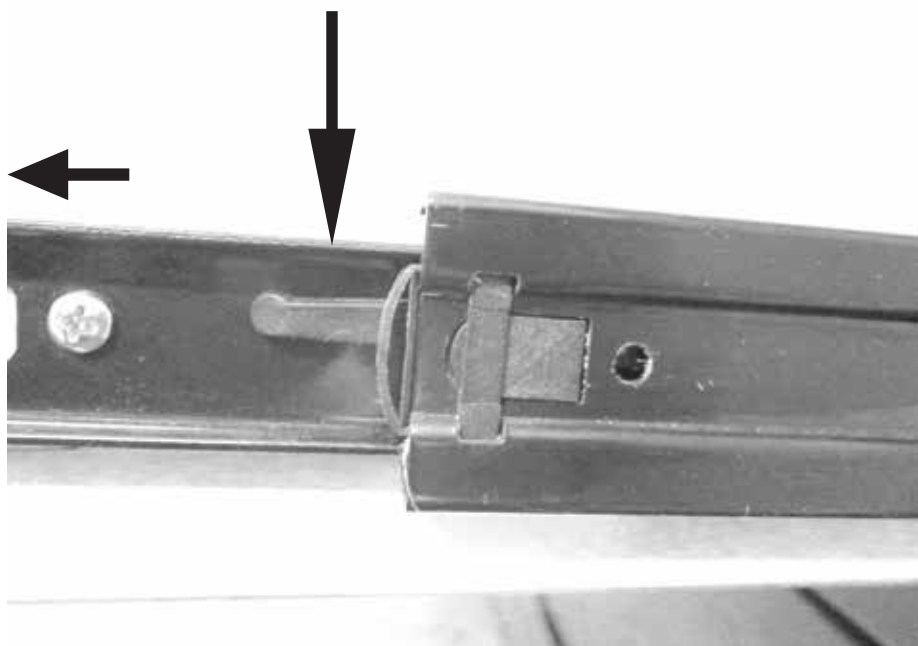

Left Side Push Lever Up
Côté gauche Up Pousser le levier
empuje la palanca izquierda hacia arriba

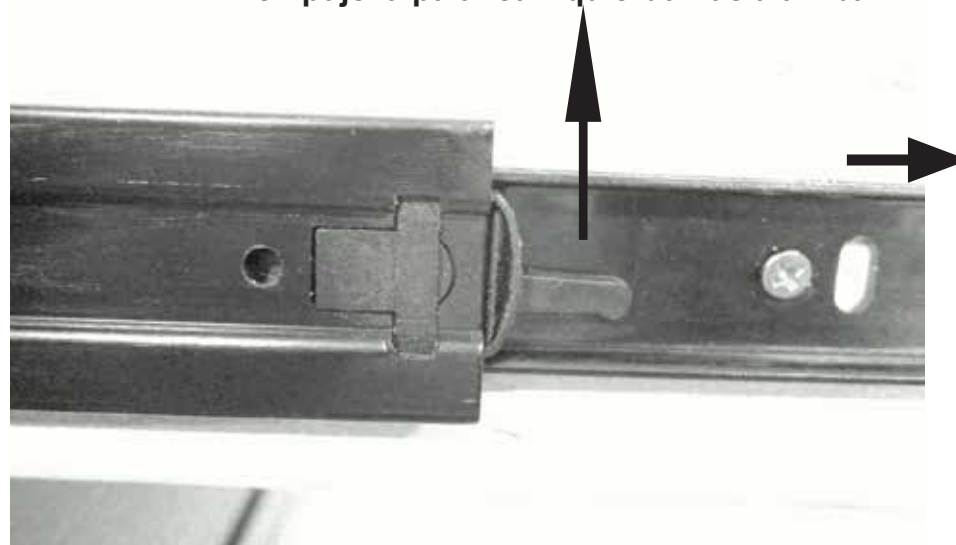

The silver portion of the glide must be pulled to the front of the glide when assembling the drawer into the case.

La partie argentée du glissement de doit être tirée vers l'avant de la glisse lors du montage du tiroir dans le boîtier.

La parte plateada de la guía de la gaveta debe estar al frente de la guía cuando se está armando la cómoda.

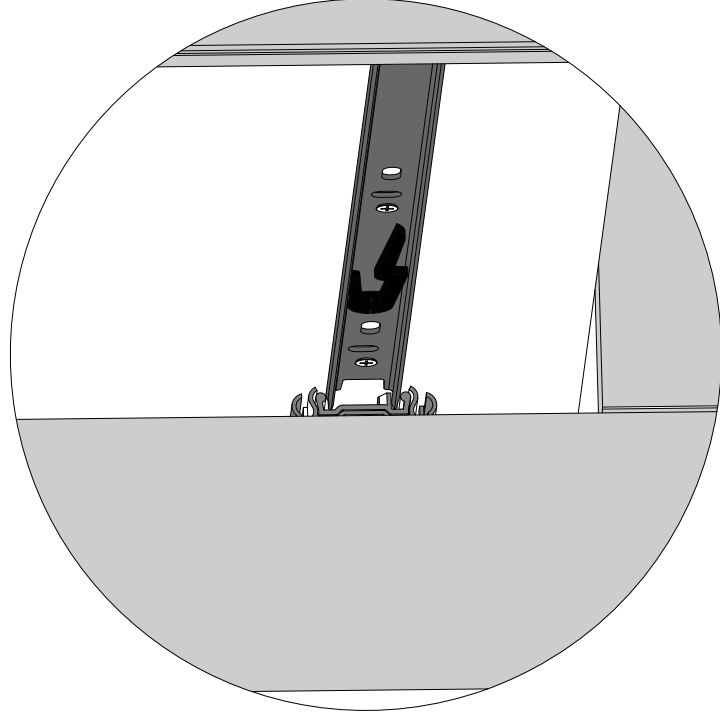
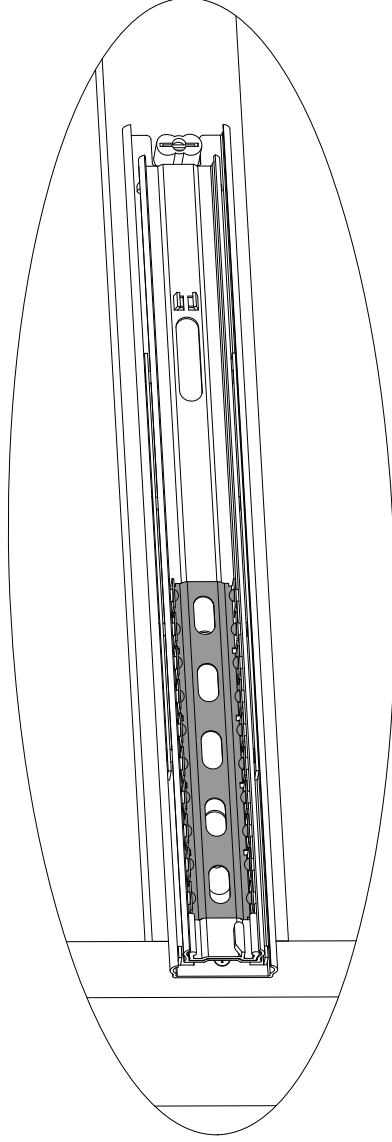
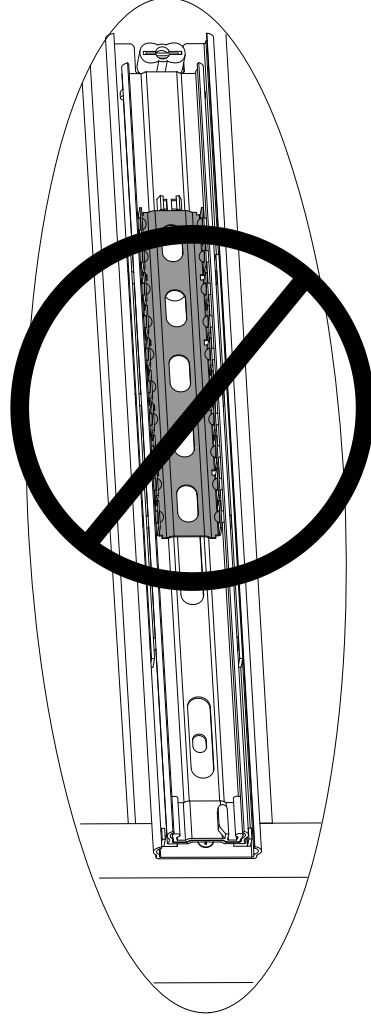
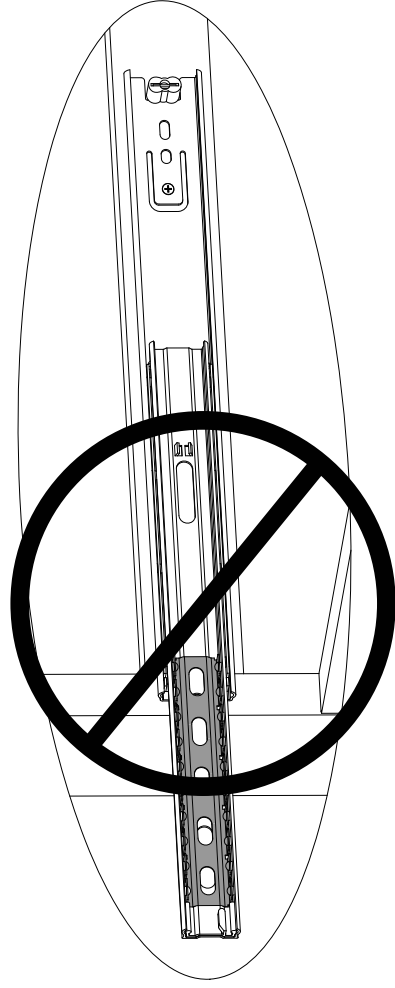

To insert drawer align male runner on drawer to female runner on case and push all the way in.

Pour insérer tiroir aligner runner homme sur le tiroir pour runner femme sur l'affaire et poussez jusqu'à ce qu'il repose.

Para insertar cajón alinear runner mujer en el cajón para de hombre runner case y empuje hasta el fondo.