

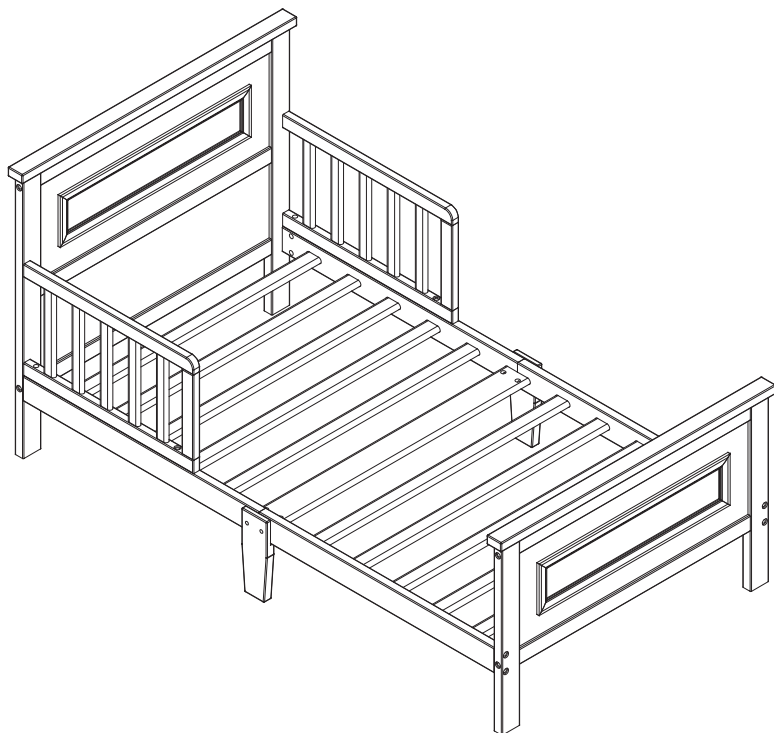

Read all instructions before assembly and use.
KEEP INSTRUCTIONS FOR FUTURE USE.

⚠ ADULT ASSEMBLY REQUIRED
Due to the presence of small parts during assembly, keep out of reach of children until assembly is complete.



THIS PRODUCT IS NOT INTENDED FOR INSTITUTIONAL OR COMMERCIAL USE.



Consumer Care:
www.DeltaChildren.com

Delta Children's Products
114 West 26th Street
New York, NY 10001
Tele. 212-645-9033

Style #: _____
Lot: _____
Date: _____



When contacting Delta Consumer Care please reference the above information. Before contacting Delta Consumer Care please ensure that the information above matches the information found on the label on the Headboard bottom rail, please reference the information found on the product when contacting Delta Consumer Care.

To register your product for important safety alerts and updates to your product please visit www.DeltaChildren.com and click on Product Registration.

TODDLER BED

WARNING

INFANTS HAVE DIED IN TODDLER BEDS FROM ENTRAPMENT.

Openings in and between bed parts can entrap head and neck of a small child.
NEVER use bed with children younger than 15 months.
ALWAYS follow assembly instructions.
The maximum user weight is 50lbs (22.7kg)

WARNING

STRANGULATION HAZARD

NEVER place bed near windows where cords from blinds or drapes may strangle a child.
NEVER suspend strings over a bed.
NEVER place items with a string, cord, or ribbon, such as hood strings or pacifier cords, around a child's neck. These items may catch on bed parts.

CAUTION

ENTRAPMENT HAZARD

To avoid dangerous gaps, any mattress used in this bed shall be a full-size crib mattress at least 51 5/8 in. (1310 mm) in length, 27 1/4 in. (690 mm) in width., and a max thickness of 5 3/4 in. (146 mm).

NOTES ON ASSEMBLY:

- During the assembly process whenever using screws or bolts, check each by placing the screw/bolt on the diagram of the item which is drawn actual size and design. Be sure to use the proper size and shape specified in the instructions.
- To assemble this unit you may be required to place the unit on it's side and face. It is strongly recommended that assembly is done on a soft, non-abrasive surface to avoid damaging the finish.

NOTES ON USE:

Keep children and others safe by following these simple rules:

- **Do not** allow any child to play on furniture
- **Do not** allow climbing on any piece of furniture.
- **Do not** allow hanging from any piece of furniture.
- Always monitor your child's activity when in the nursery.

NOTES ON CARE AND MAINTENANCE:

- **Do not** scratch or chip the finish.
- Inspect the product periodically, contact Delta Children's Products for replacement parts or questions.
- **Do not** store the product or any parts in extreme temperatures and conditions such as a hot attic or a damp, cold basement. These extremes can cause a loss of structural integrity.
- To preserve the luster of the high quality finish on your product, it is recommended to place a doily or felt pad under any items you place on the finish.
- Clean with a damp cloth, then a dry cloth to preserve the original luster and beauty of this fine finish.
- Do not** use abrasive chemicals.
- Do not** spray cleaners directly onto furniture.
- Lift slightly when moving on carpeting to prevent leg breakage.
- Use of a vaporizer near furniture will cause wood to swell and finish to peel.

PARTS: MAKE SURE THAT ALL PRE-ASSEMBLED PARTS ARE TIGHT.

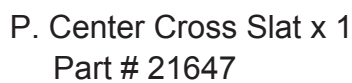
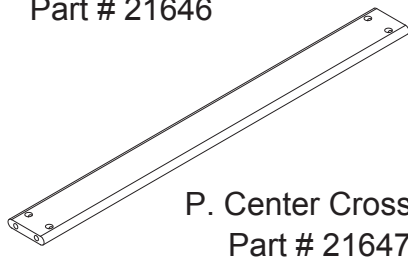
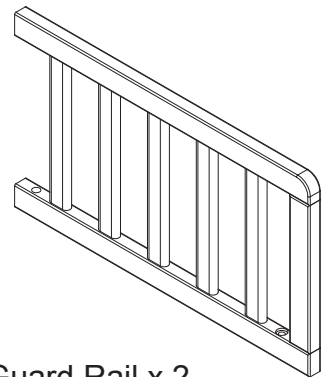
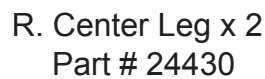
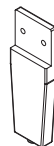
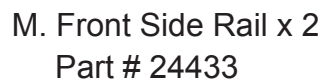
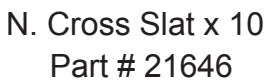
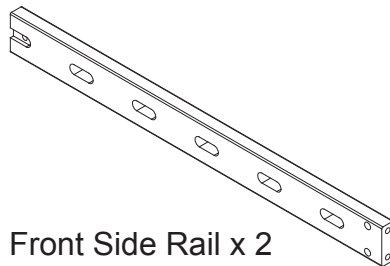
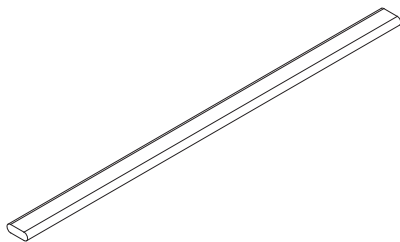
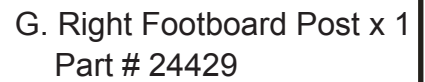
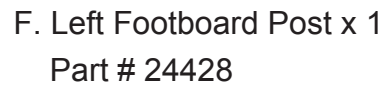
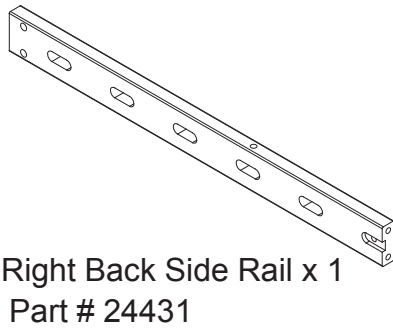
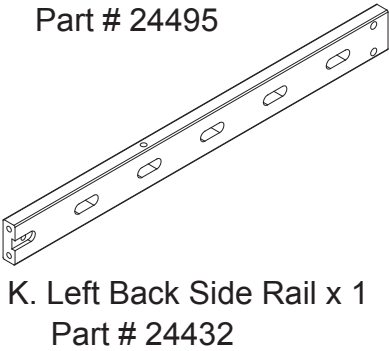
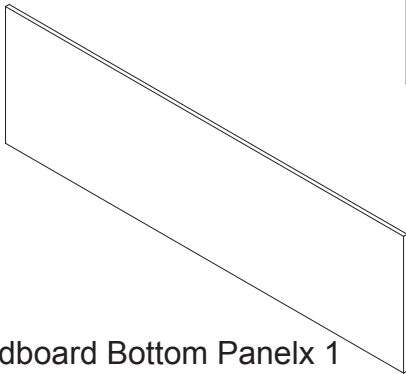
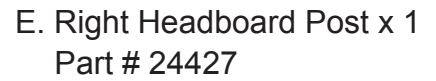
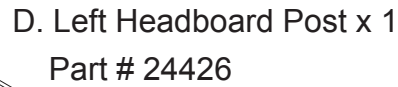
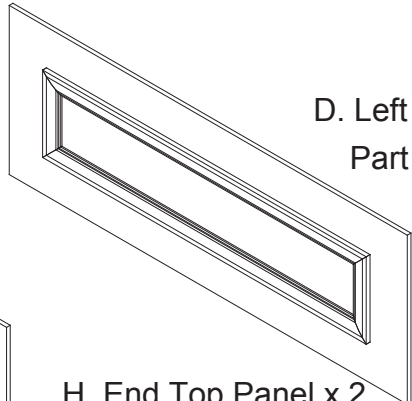
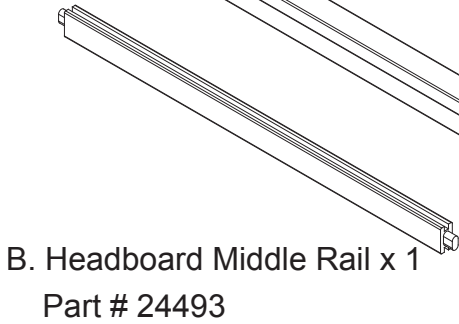
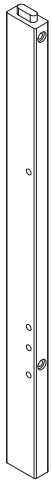
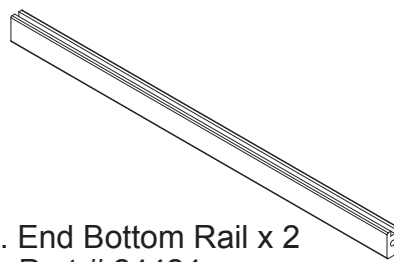
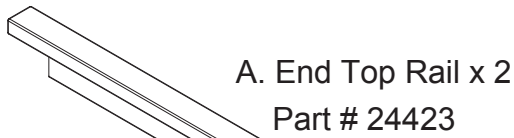

PARTS: HARDWARE KIT PART #24434-986 FOR COLOR 100 OR #24434-988 FOR COLOR 607. SEE FRONT COVER.

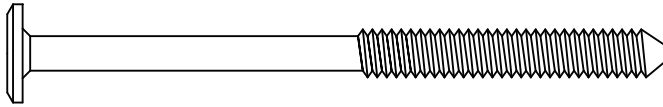
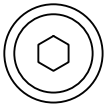

T. M6 x 85 mm Bolt x 8
Part # 5474

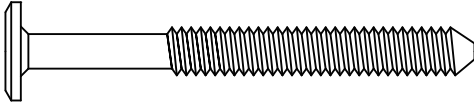
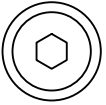

U. M6 x 60 mm Bolt x 16
Part # 5469

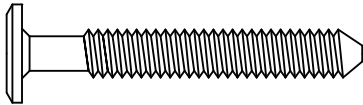
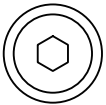

V. M6 x 45 mm Bolt x 2
Part # 5466

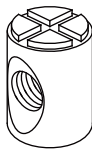

W. M6x13 mm Barrel Nut x 24
Part # 5483



X. Φ 8x40 mm Wood Dowel x 4
Part # 5672

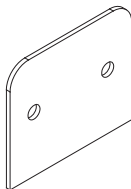

Y. Mending Plate x 2
Part # 5673

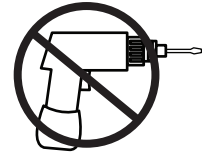

No drills necessary. Do not use power screwdriver.



Flat Head Screwdriver
(not supplied)

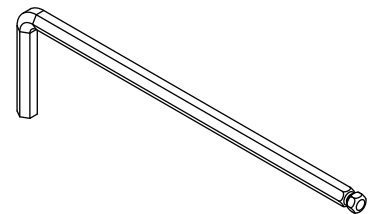

M4 Allen Wrench Supplied
Part # 1177

Step 1

Parts and tools required to complete step.

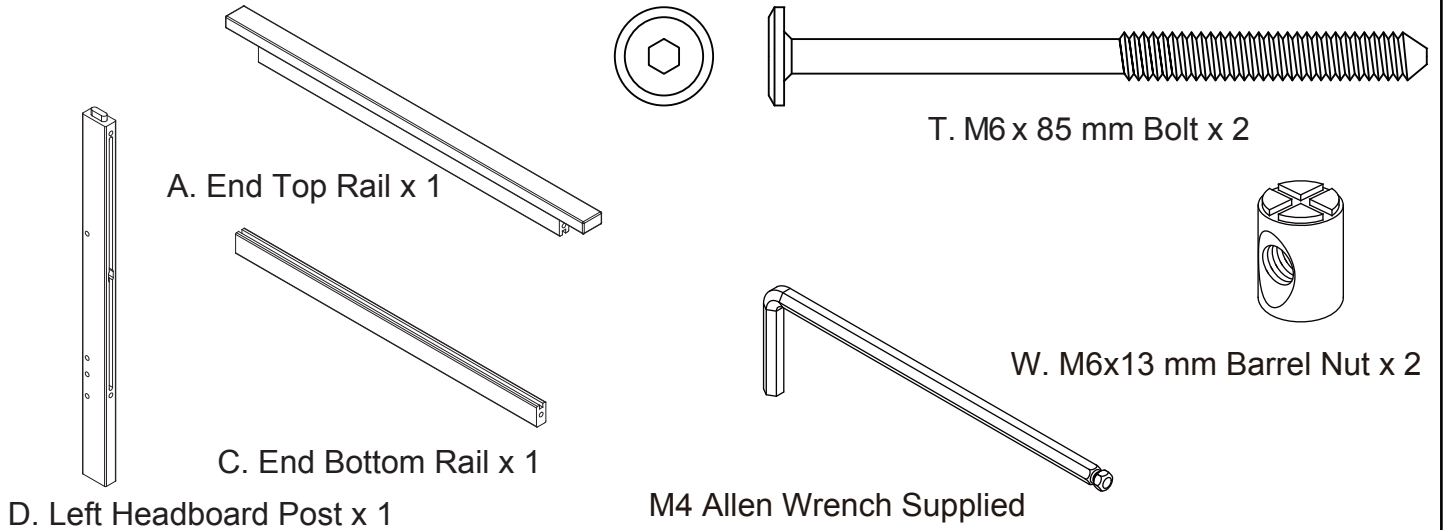

Attach (1) End Top Rail (Part A) and (1) End Bottom Rail (Part C) to (1) Left Headboard Post (Part D) using (2) M6x85mm Bolts (Part T) and (2) M6x13mm Barrel Nuts (Part W). Tighten with the M4 Allen Wrench. Use the Flat Head Screwdriver to hold the Barrel Nut in the proper alignment.

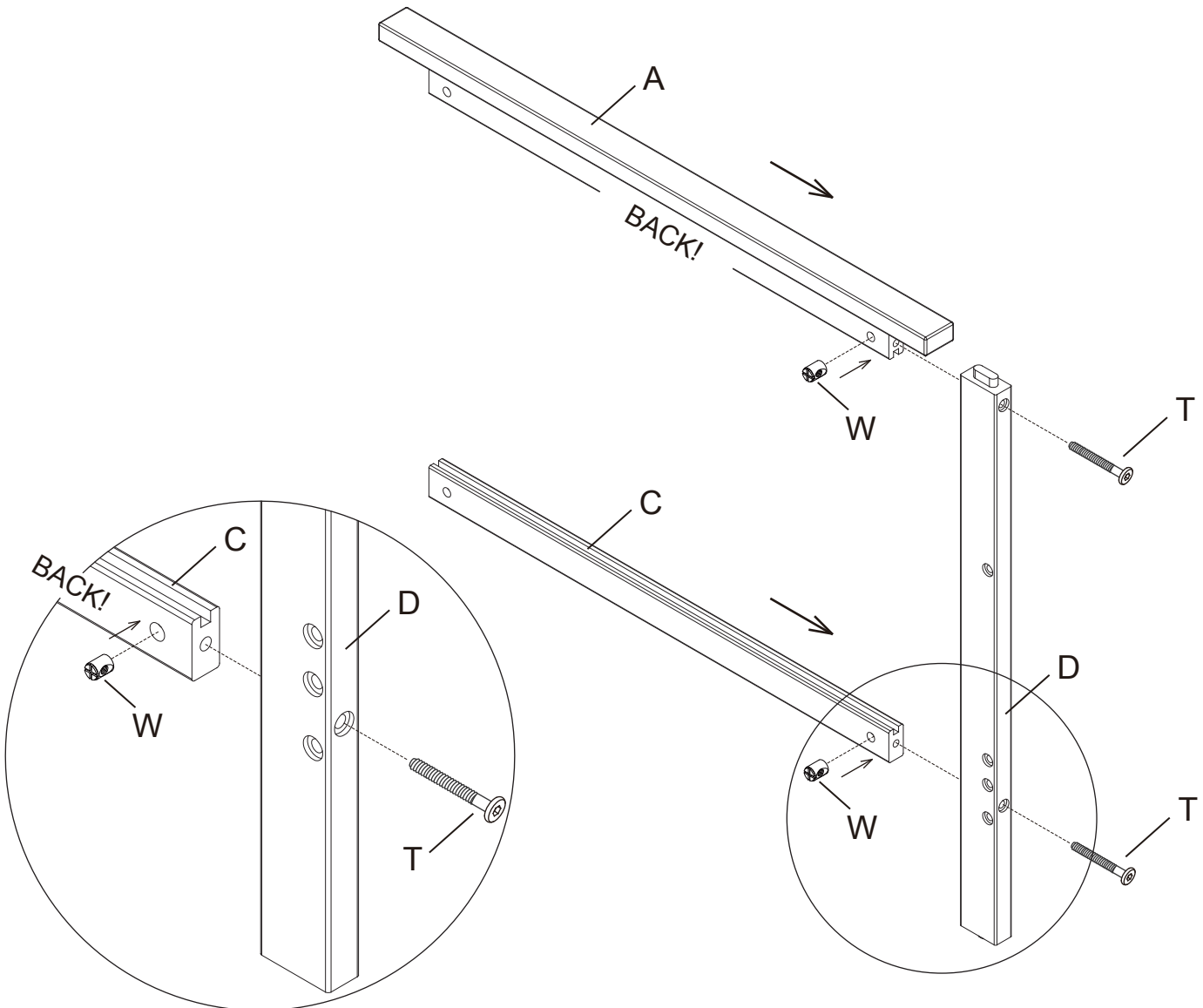

Step 2

Parts and tools required to complete step.

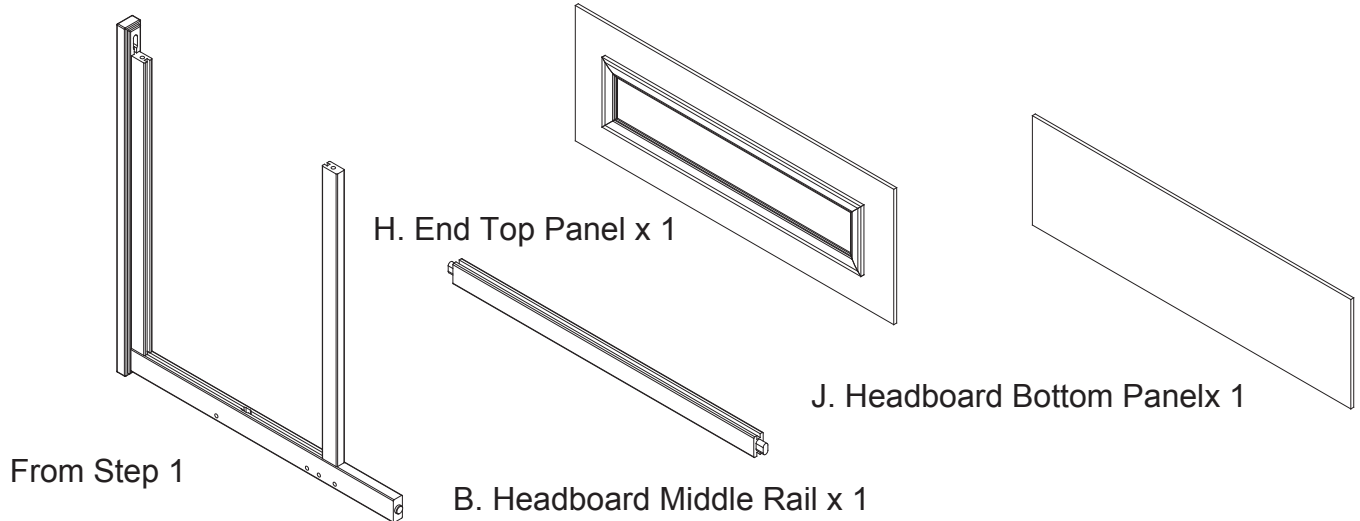

Insert (1) Headboard Middle Rail (Part B) as shown.

Slide End Top Panel (Part H) into End Top Rail (Part A) and Headboard Middle Rail (Part B) Grooves as shown.

Slide Headboard Bottom Panel (Part J) into Headboard Middle Rail (Part B) and End Bottom Rail (Part C) Grooves as shown.

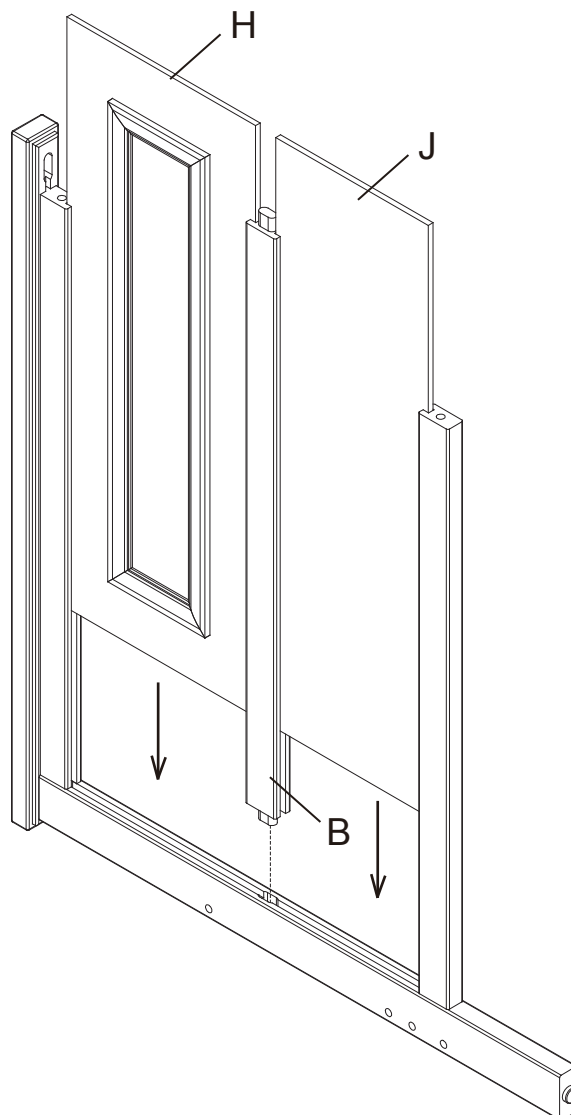

Step 3

Parts and tools required to complete step.

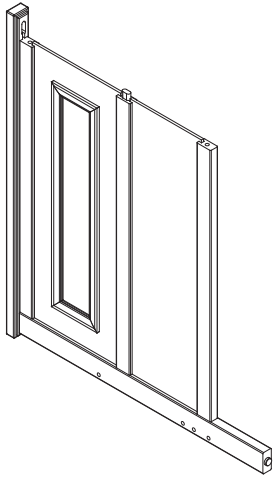

From Step 2



E. Right Headboard Post x 1

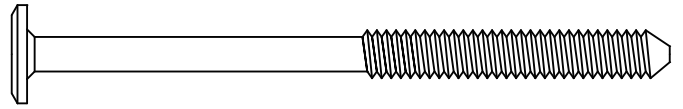
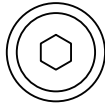

T. M6 x 85 mm Bolt x 2

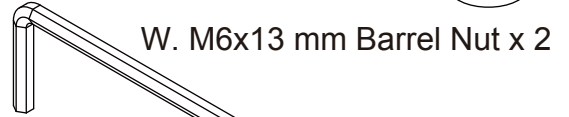
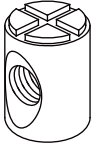

W. M6x13 mm Barrel Nut x 2

M4 Allen Wrench Supplied

Attach (1) Right Headboard Post (Part E) to the assembly from step 2 using (2) M6x85mm Bolts (Part T) and (2) M6x13mm Barrel Nuts (Part W). Tighten with the M4 Allen Wrench. Use the Flat Head Screwdriver to hold the Barrel Nut in the proper alignment.

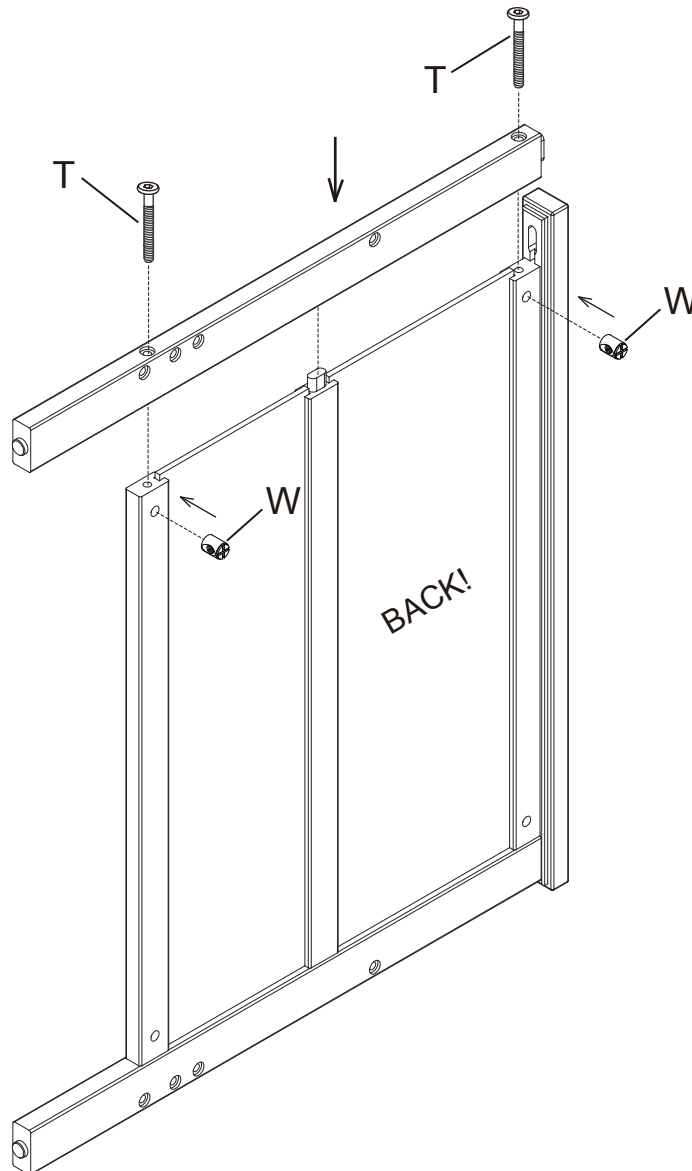

Step 4

Parts and tools required to complete step.

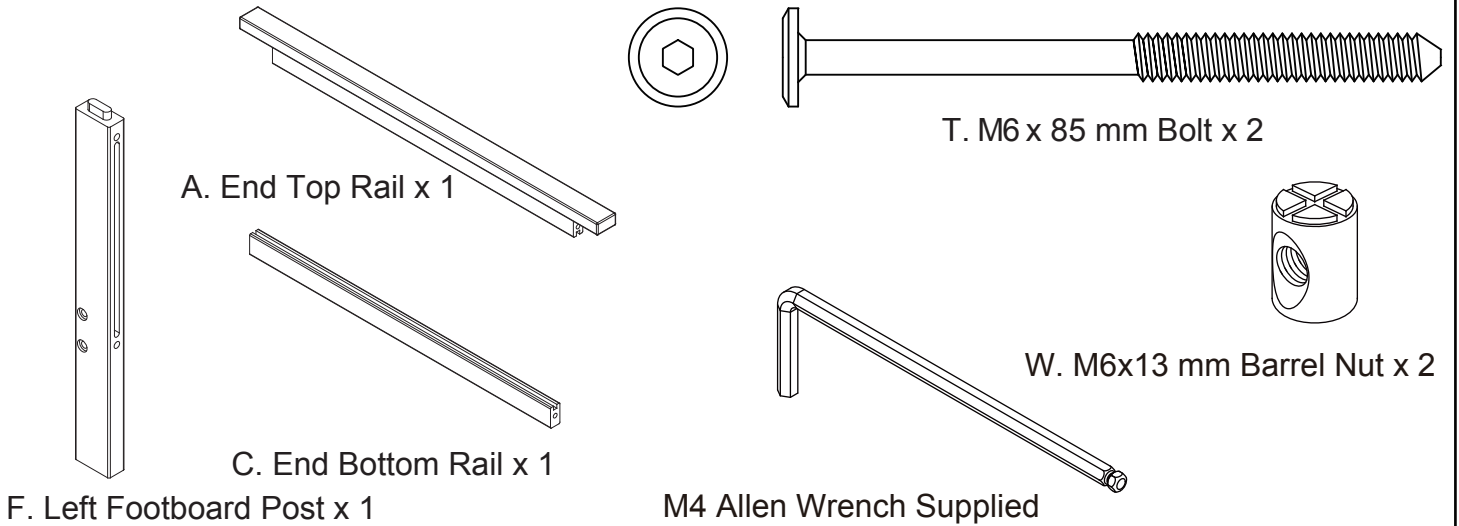

Attach (1) End Top Rail (Part A) and (1) End Bottom Rail (Part C) to (1) Left Footboard Post (Part F) using (2) M6x85mm Bolts (Part T) and (2) M6x13mm Barrel Nuts (Part W). Tighten with the M4 Allen Wrench. Use the Flat Head Screwdriver to hold the Barrel Nut in the proper alignment.

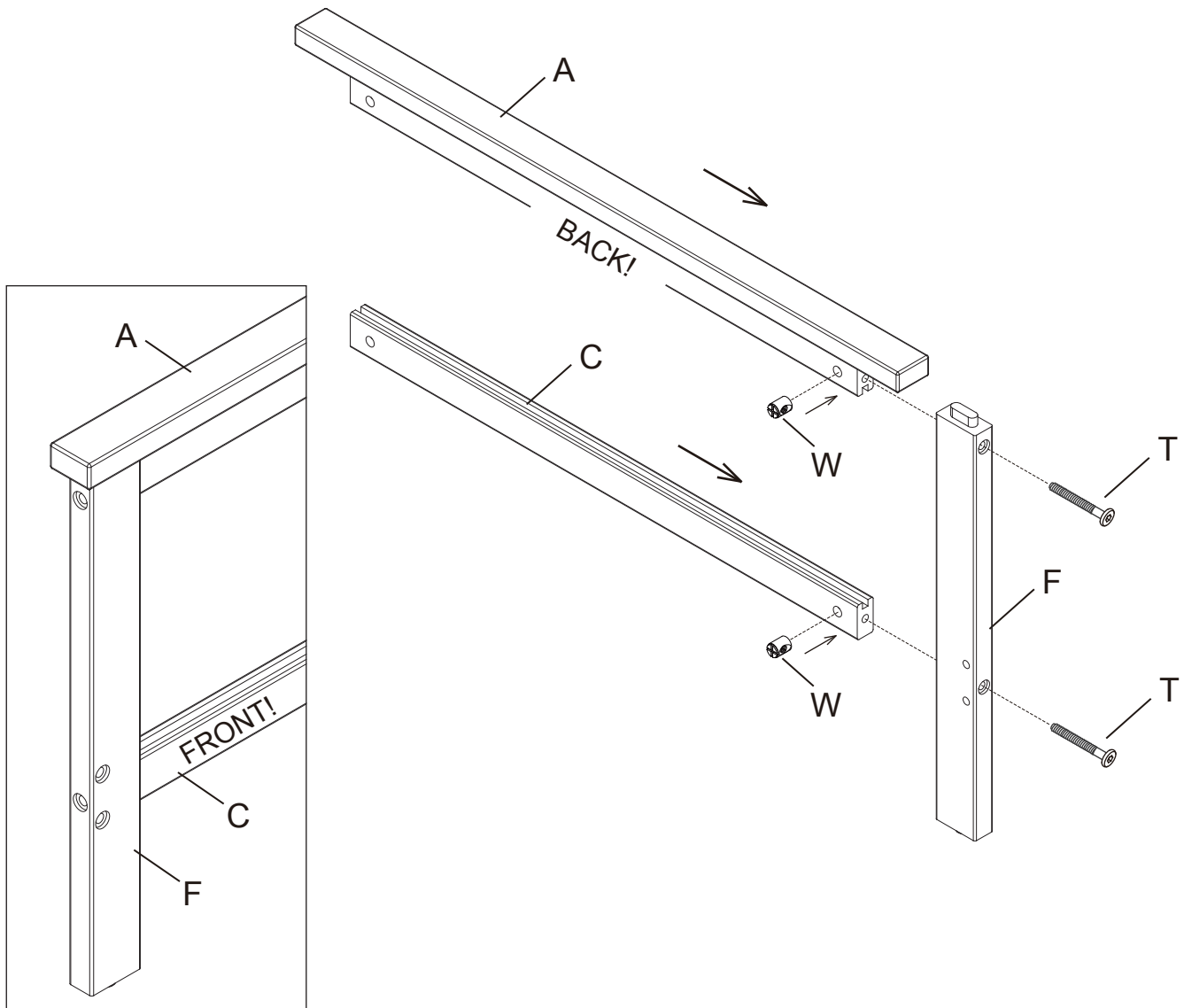

Step 5

Parts and tools required to complete step.

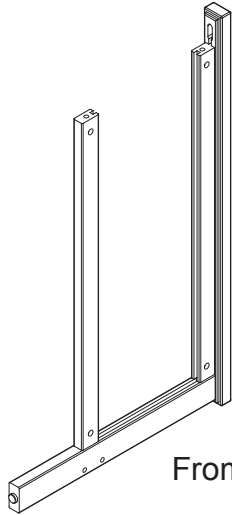

From Step 4

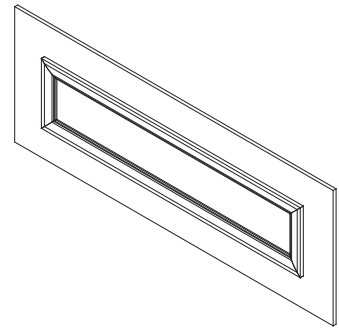

H. End Top Panel x 1

Slide End Top Panel (Part H) into End Top Rail (Part A) and End Bottom Rail (Part C) Grooves as shown.

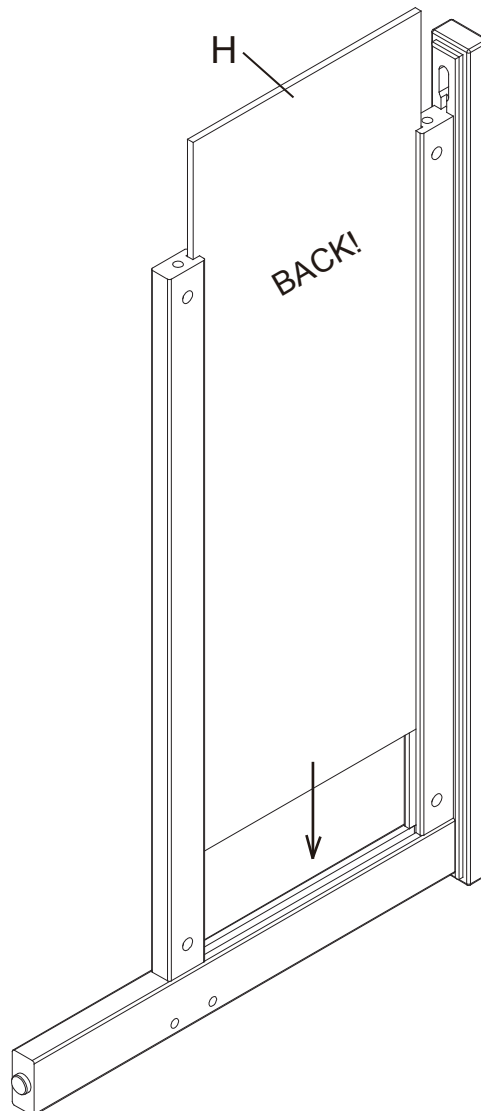

Step 6

Parts and tools required to complete step.

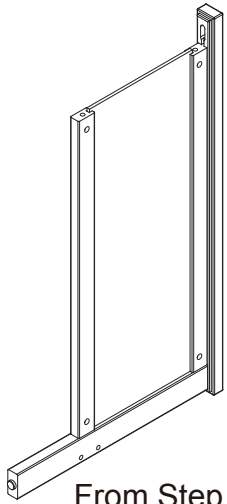

From Step 5



G. Right Footboard Post x 1

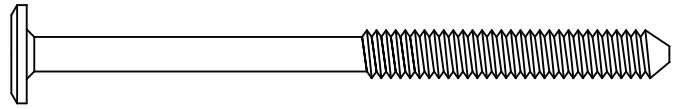
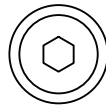

T. M6 x 85 mm Bolt x 2

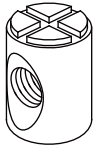

W. M6x13 mm Barrel Nut x 2

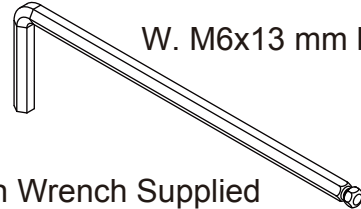

M4 Allen Wrench Supplied

Attach (1) Right Footboard Post (Part G) to the assembly from step 5 using (2) M6x85mm Bolts (Part T) and (2) M6x13mm Barrel Nuts (Part W). Tighten with the M4 Allen Wrench. Use the Flat Head Screwdriver to hold the Barrel Nut in the proper alignment.

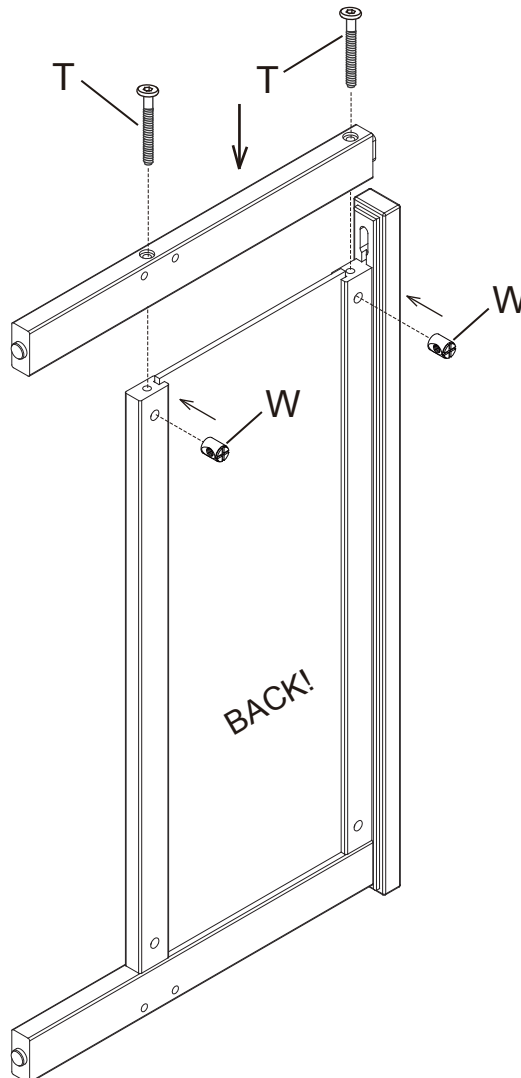

Step 7

Parts and tools required to complete step.

From Step 3

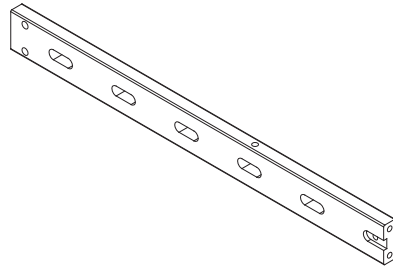
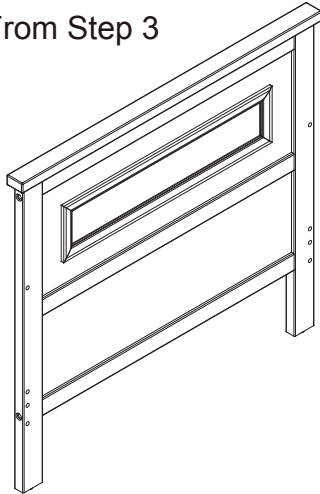

L. Right Back Side Rail x 1

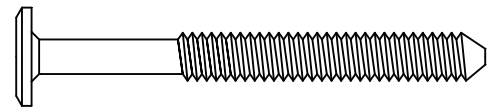
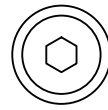

U. M6 x 60 mm Bolt x 2

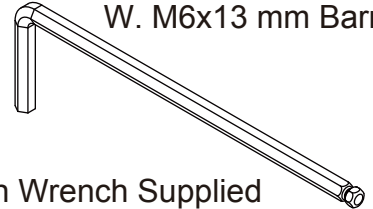
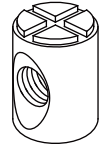

W. M6x13 mm Barrel Nut x 2

M4 Allen Wrench Supplied

Attach (1) Right Back Side Rail (Part L) to the assembly from step 3 using (2) M6x60mm Bolts (Part U) and (2) M6x13mm Barrel Nuts (Part W). Tighten with the M4 Allen Wrench. Use the Flat Head Screwdriver to hold the Barrel Nut in the proper alignment.

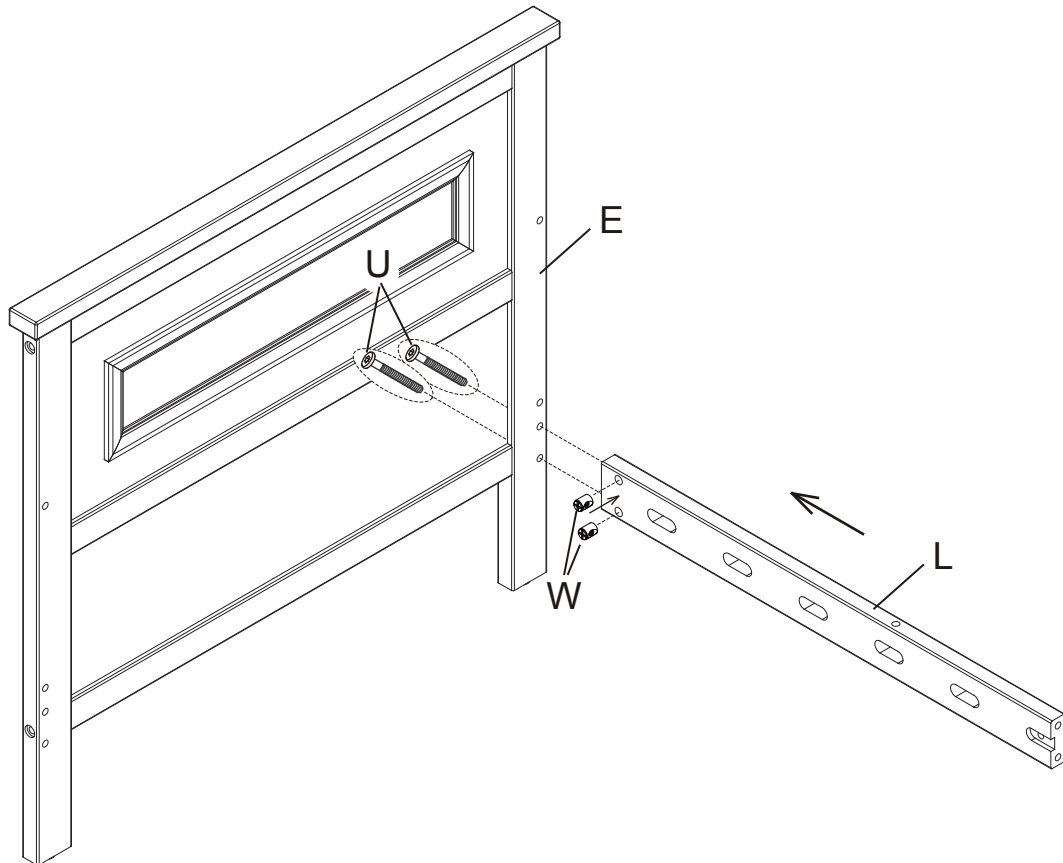

Step 8

Parts and tools required to complete step.

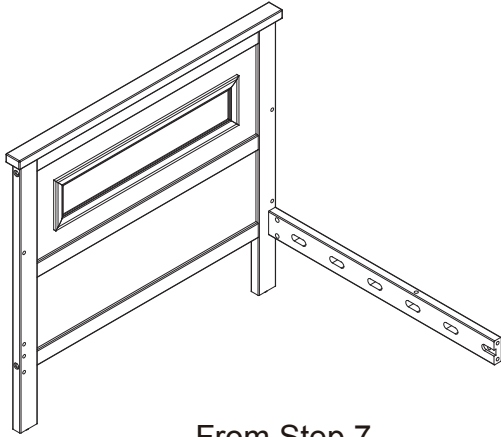

From Step 7

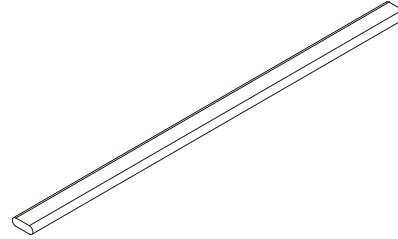

N. Cross Slat x 5

Insert (5) Cross Slats (Part N) as shown.

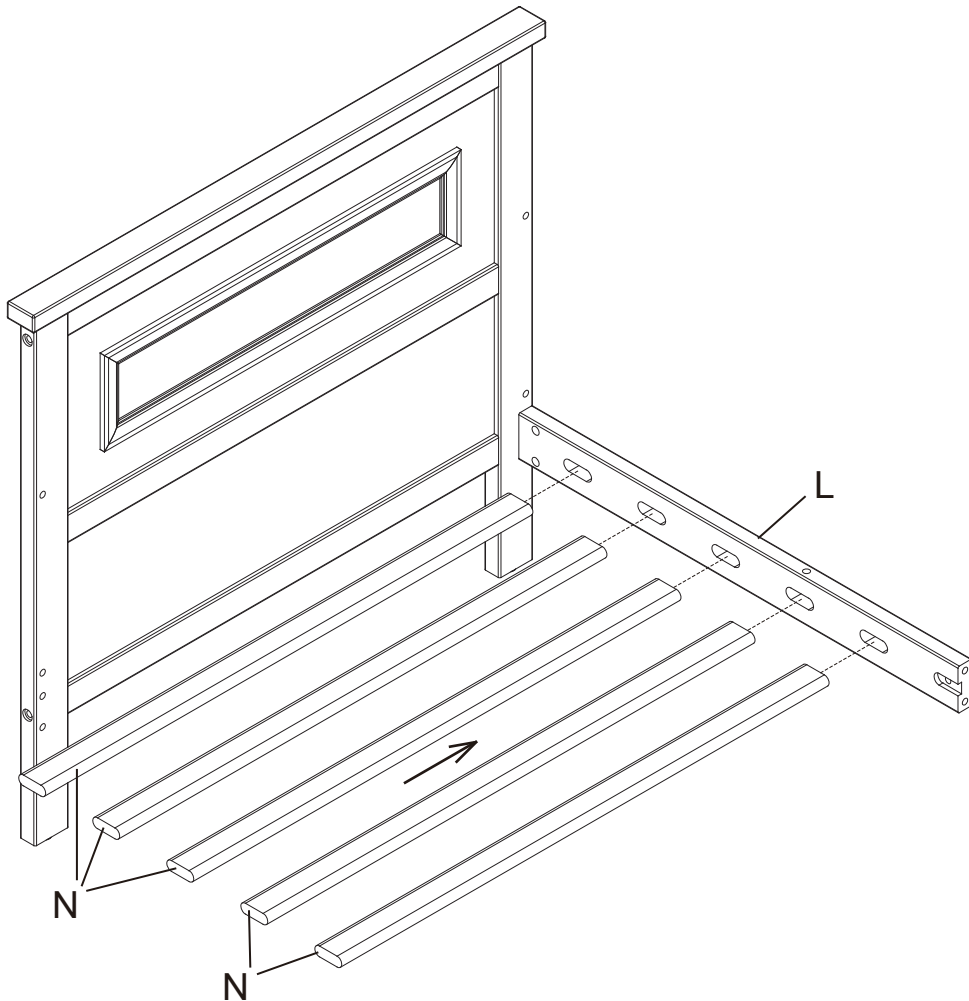

Step 9

Parts and tools required to complete step.

From Step 8

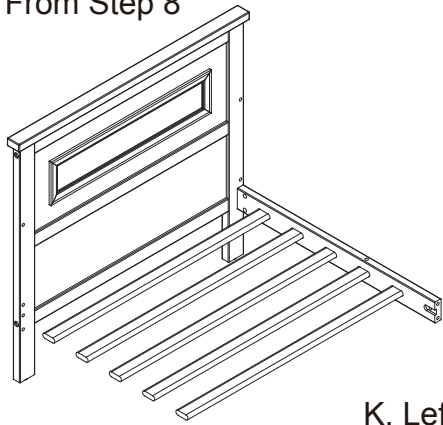

K. Left Back Side Rail x 1

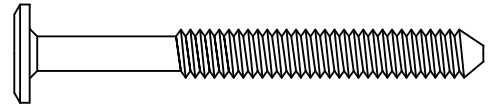
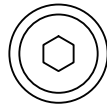

U. M6 x 60 mm Bolt x 2

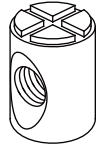

W. M6x13 mm Barrel Nut x 2

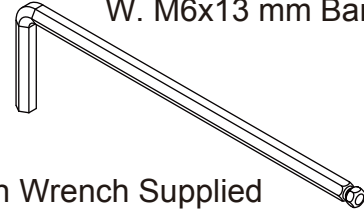

M4 Allen Wrench Supplied

Attach (1) Left Back Side Rail (Part K) to the assembly from step 8 using (2) M6x60mm Bolts (Part U) and (2) M6x13mm Barrel Nuts (Part W). Tighten with the M4 Allen Wrench. Use the Flat Head Screwdriver to hold the Barrel Nut in the proper alignment.

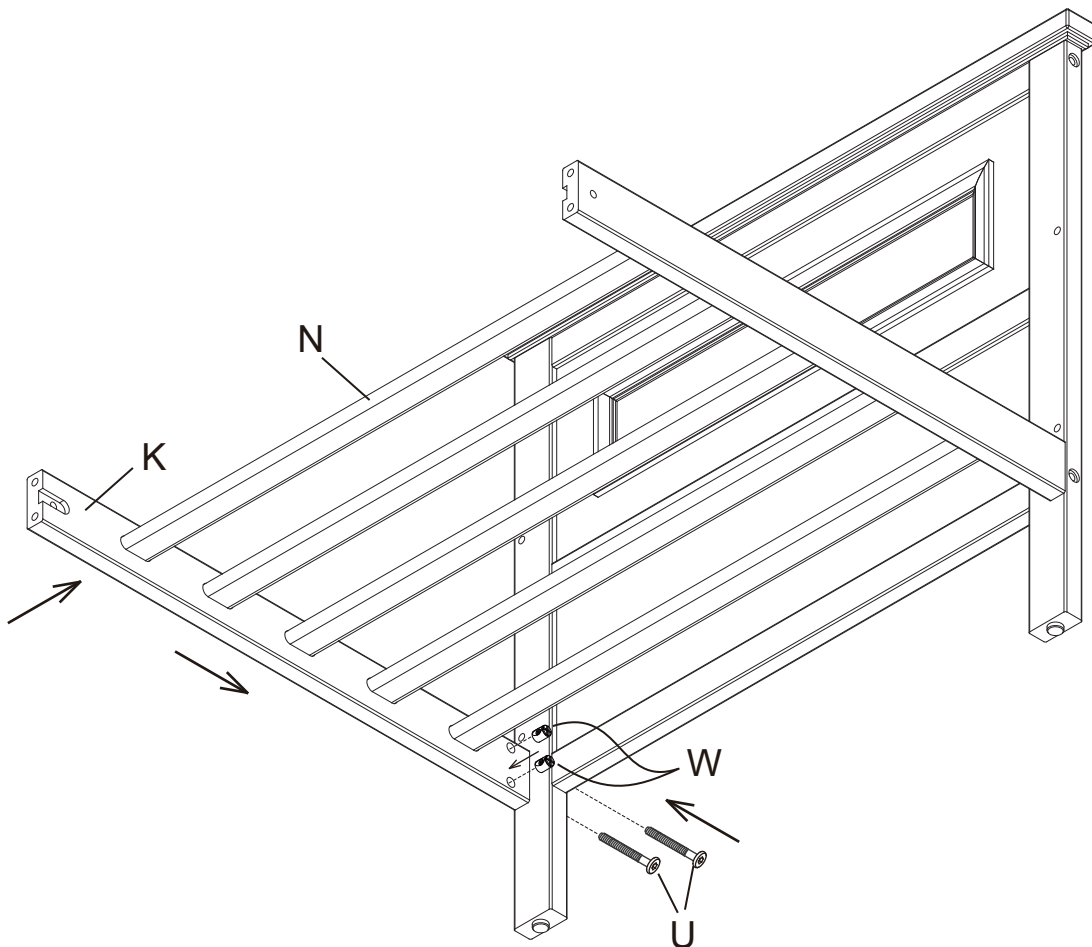

Step 10

Parts and tools required to complete step.

From Step 6

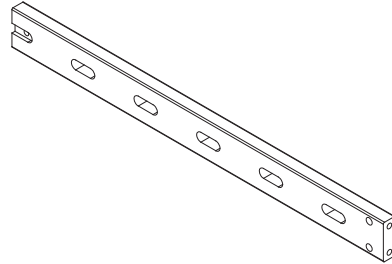
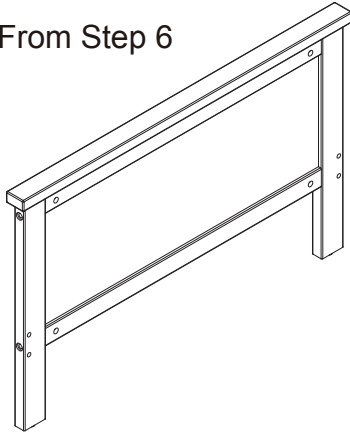

M. Front Side Rail x 1

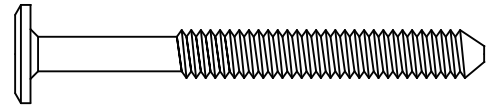
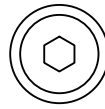

U. M6 x 60 mm Bolt x 2

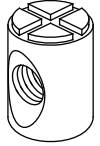

W. M6x13 mm Barrel Nut x 2

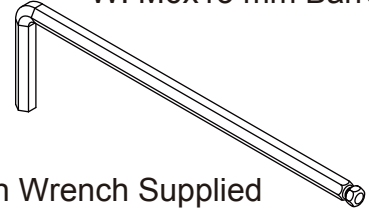

M4 Allen Wrench Supplied

Attach (1) Front Side Rail (Part M) to the assembly from step 6 using (2) M6x60mm Bolts (Part U) and (2) M6x13mm Barrel Nuts (Part W). Tighten with the M4 Allen Wrench. Use the Flat Head Screwdriver to hold the Barrel Nut in the proper alignment.

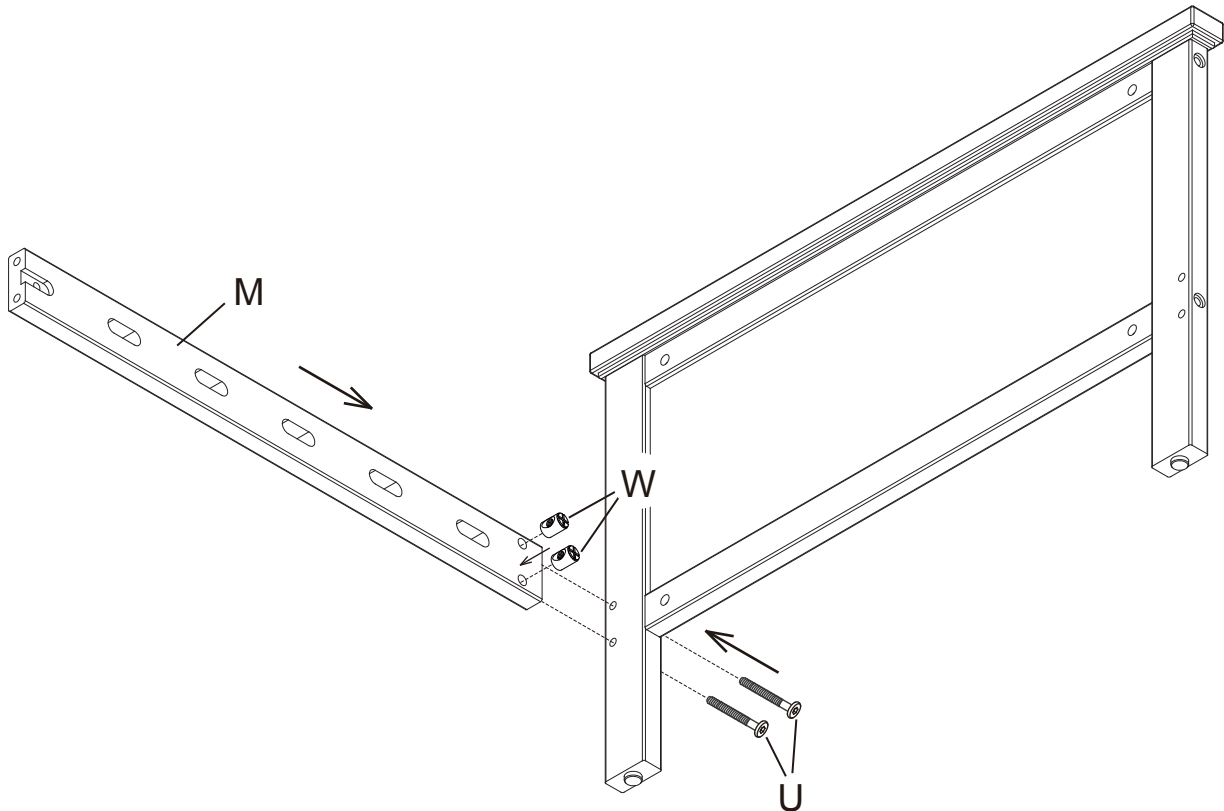

Step 11

Parts and tools required to complete step.

From Step 10

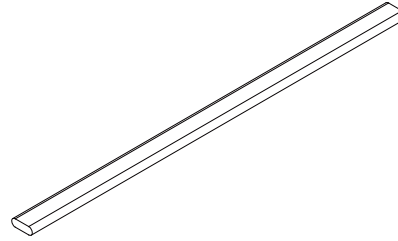
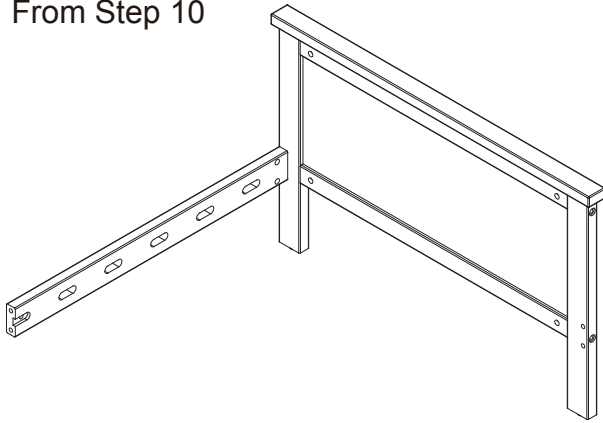

N. Cross Slat x 5

Insert (5) Cross Slats (Part N) as shown.

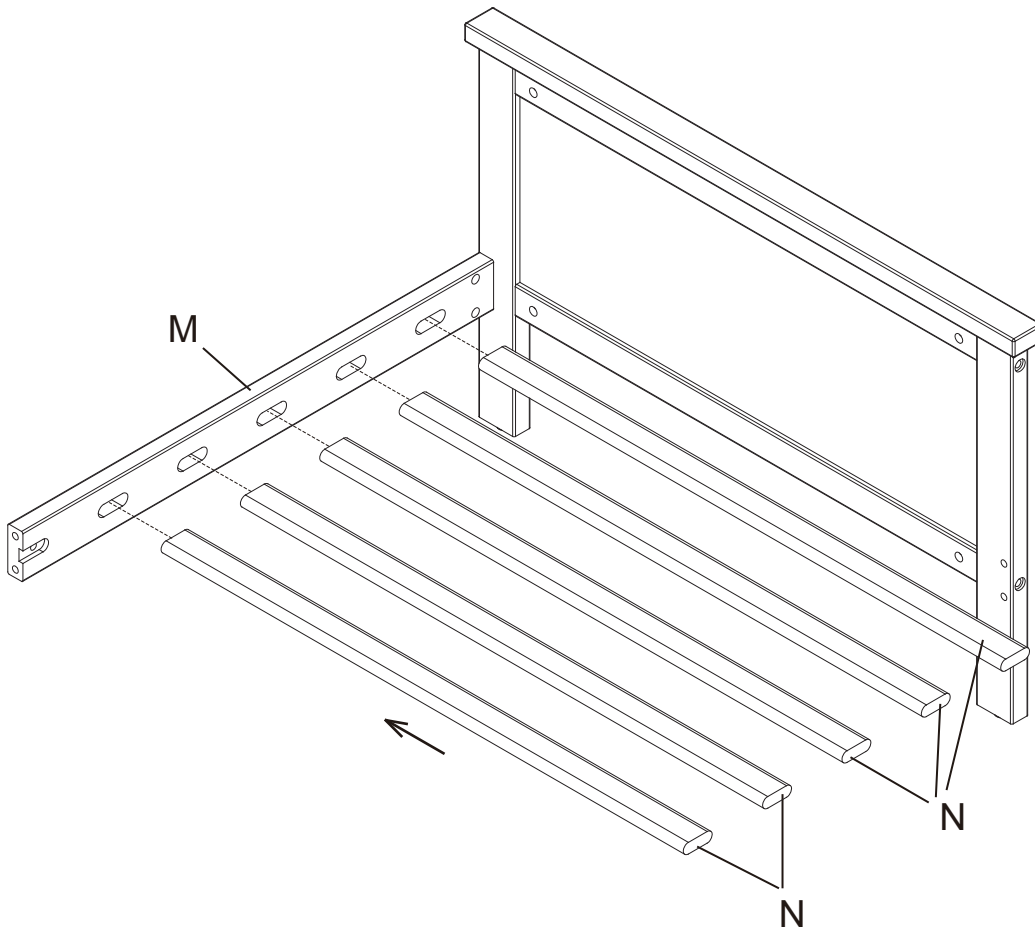

Step 12

Parts and tools required to complete step.

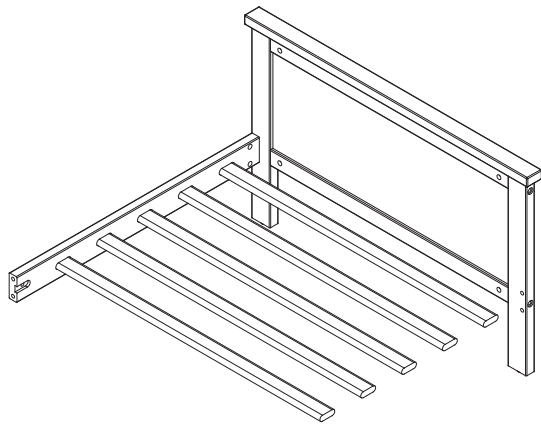

From Step 11

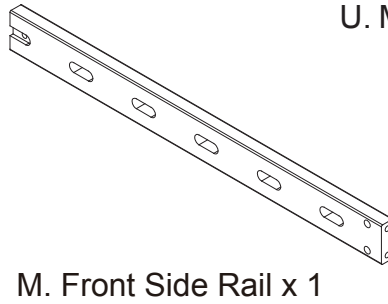

M. Front Side Rail x 1

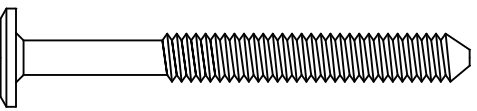
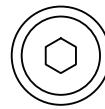

U. M6 x 60 mm Bolt x 2

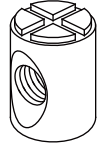

W. M6x13 mm Barrel Nut x 2

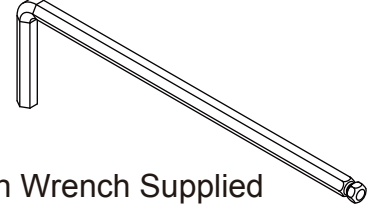

M4 Allen Wrench Supplied

Attach (1) Front Side Rail (Part M) to the assembly from step 11 using (2) M6x60mm Bolts (Part U) and (2) M6x13mm Barrel Nuts (Part W). Tighten with the M4 Allen Wrench. Use the Flat Head Screwdriver to hold the Barrel Nut in the proper alignment.

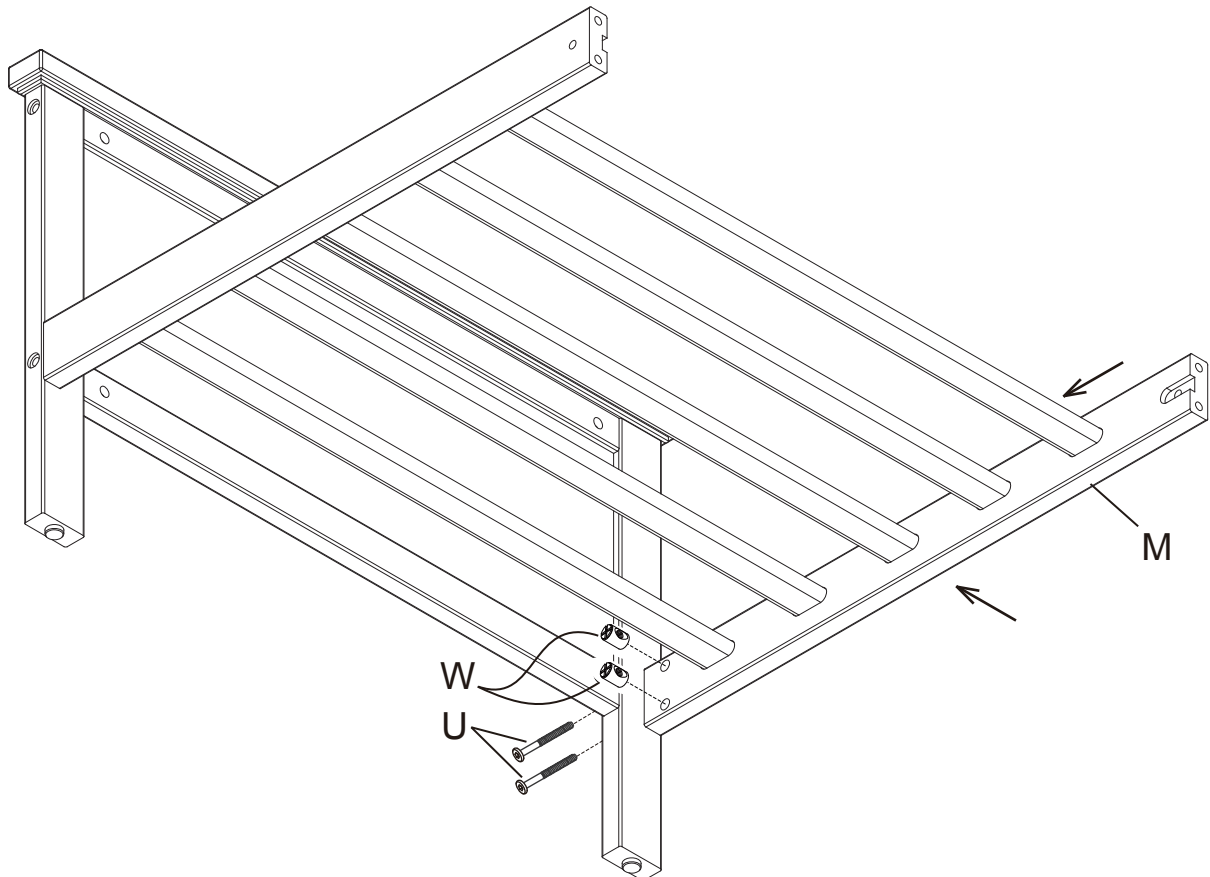

Step 13

Parts and tools required to complete step.

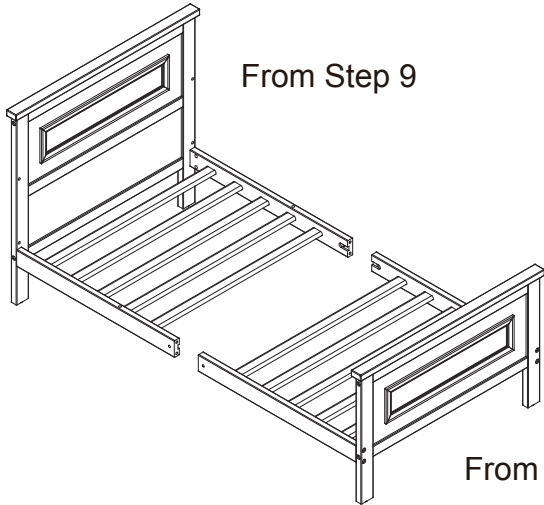

X. $\Phi 8 \times 40$ mm Wood Dowel x 4

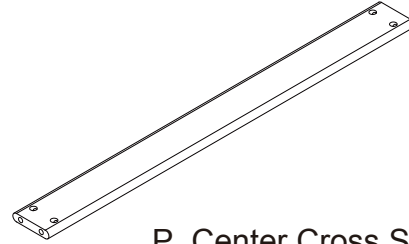

P. Center Cross Slat x 1

Insert (1) Center Cross Slat (Part P) in the grooves on the end of the Front Side Rails (Part M). Attach the assembly from step 12 to the assembly from step 9 using (4) $\Phi 8 \times 40$ mm Wood Dowels (Part X).

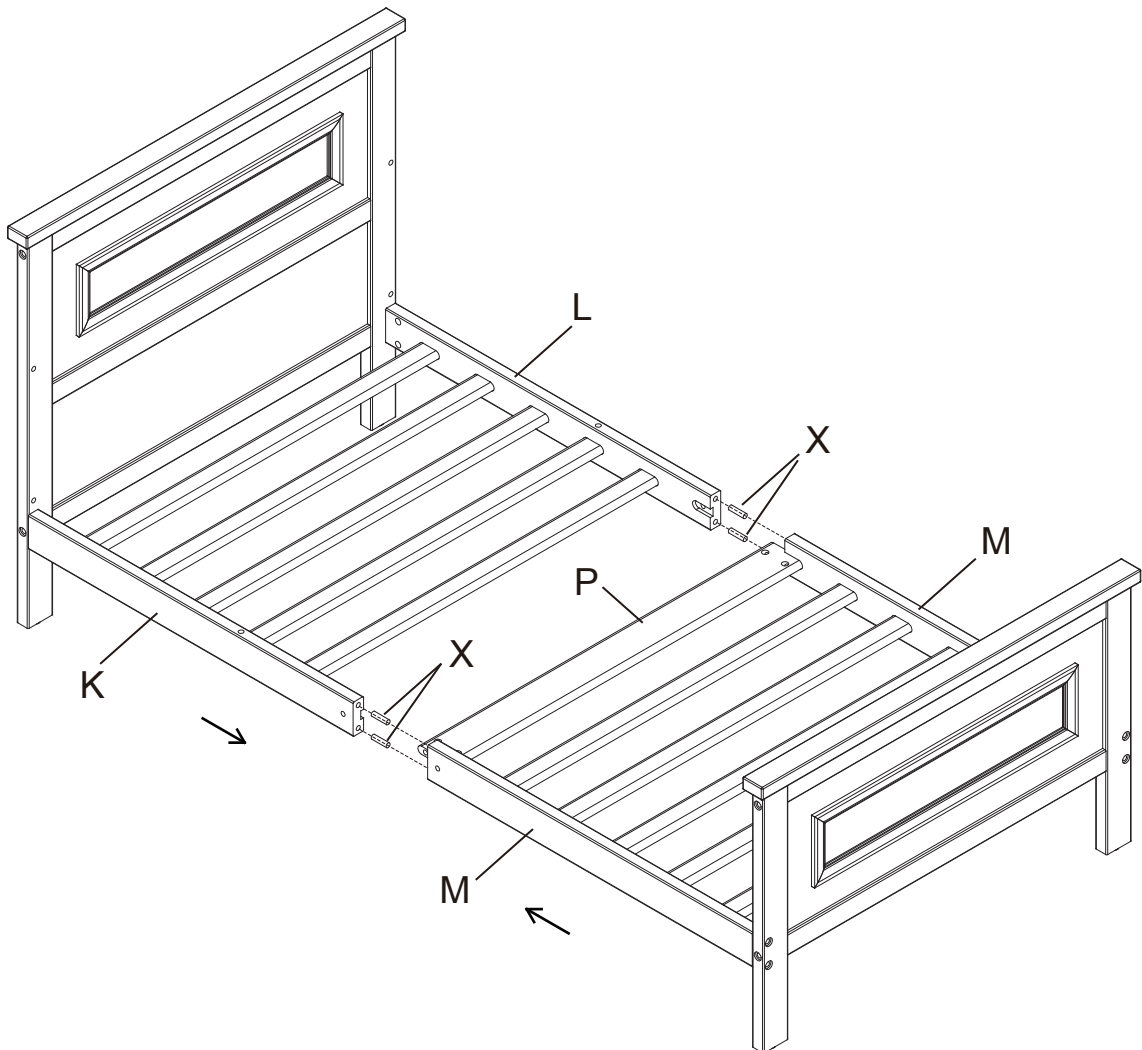

Step 14

Parts and tools required to complete step.

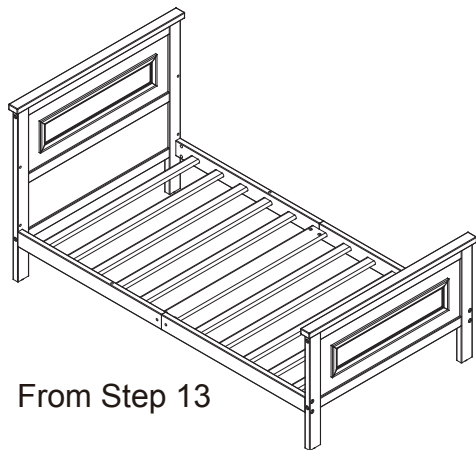

From Step 13



R. Center Leg x 2

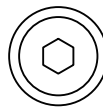

U. M6 x 60 mm Bolt x 4

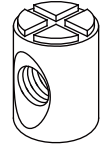

W. M6x13 mm Barrel Nut x 4

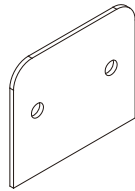

Y. Mending Plate x 2

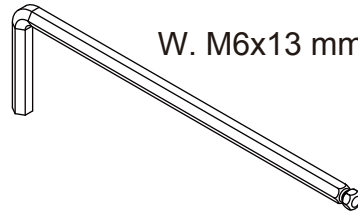

M4 Allen Wrench Supplied

Attach (2) Center Legs (Part R) to the assembly from step 13 using (2) Mending Plates (Part Y), (4) M6x60mm Bolts (Part U) and (4) M6x13mm Barrel Nuts (Part W). Tighten with the M4 Allen Wrench. Use the Flat Head Screwdriver to hold the Barrel Nut in the proper alignment.

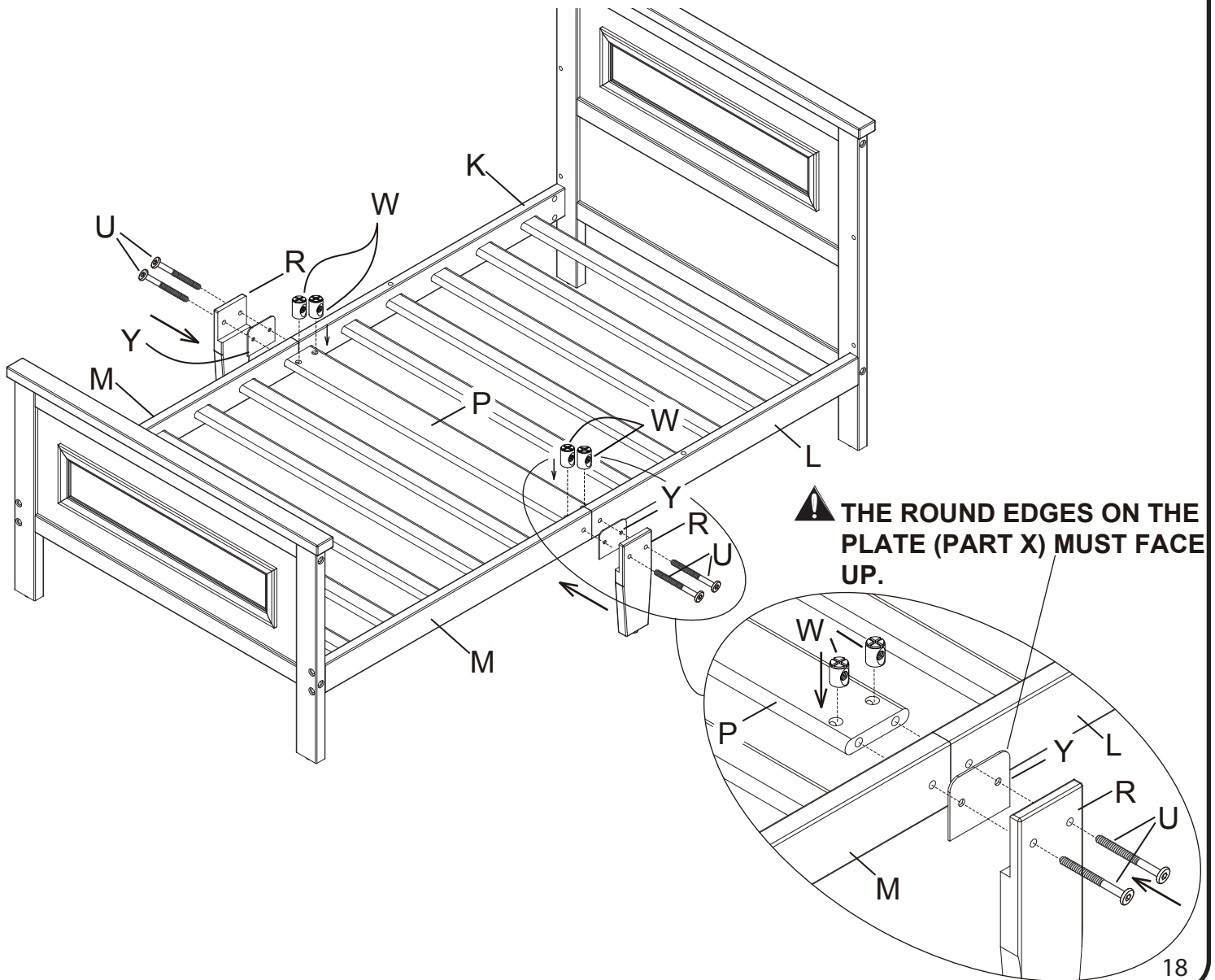

Step 15

Parts and tools required to complete step.

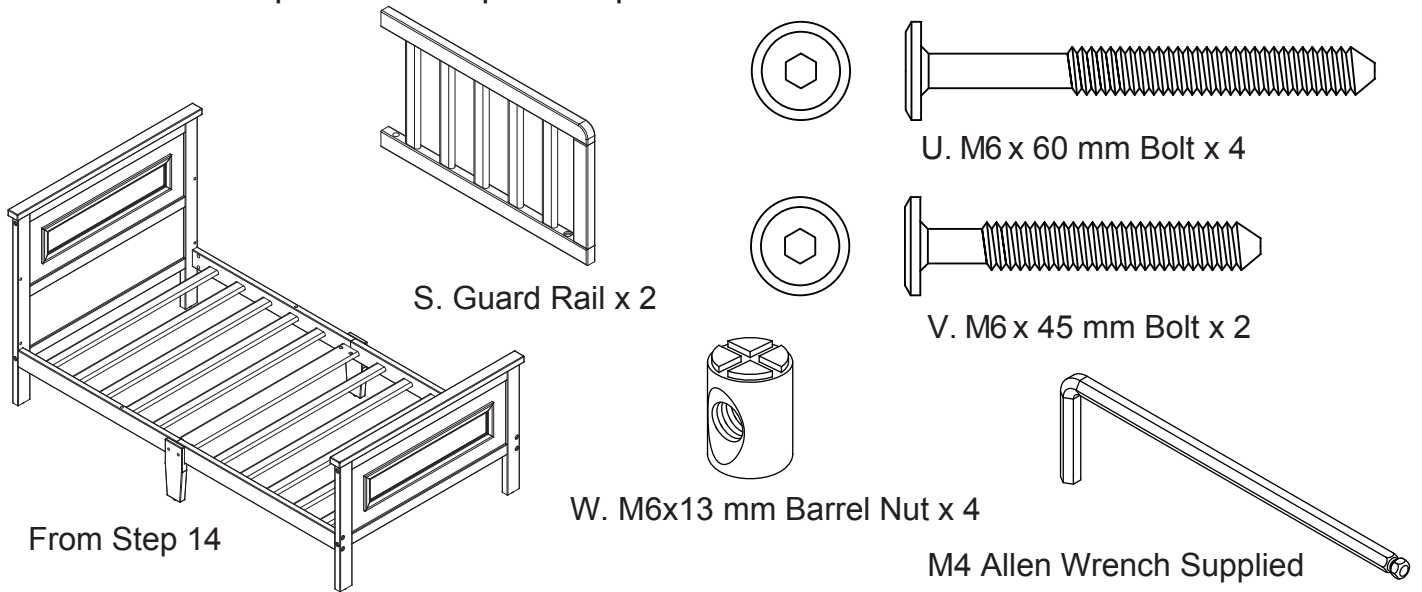

Attach (2) Guardrails (Part S) to the assembly from step 14 using (2) M6x45mm Bolts (Part V), (4) M6x60mm Bolts (Part U) and (4) M6x13mm Barrel Nuts (Part W). Tighten with the M4 Allen Wrench. Use the Flat Head Screwdriver to hold the Barrel Nut in the proper alignment.

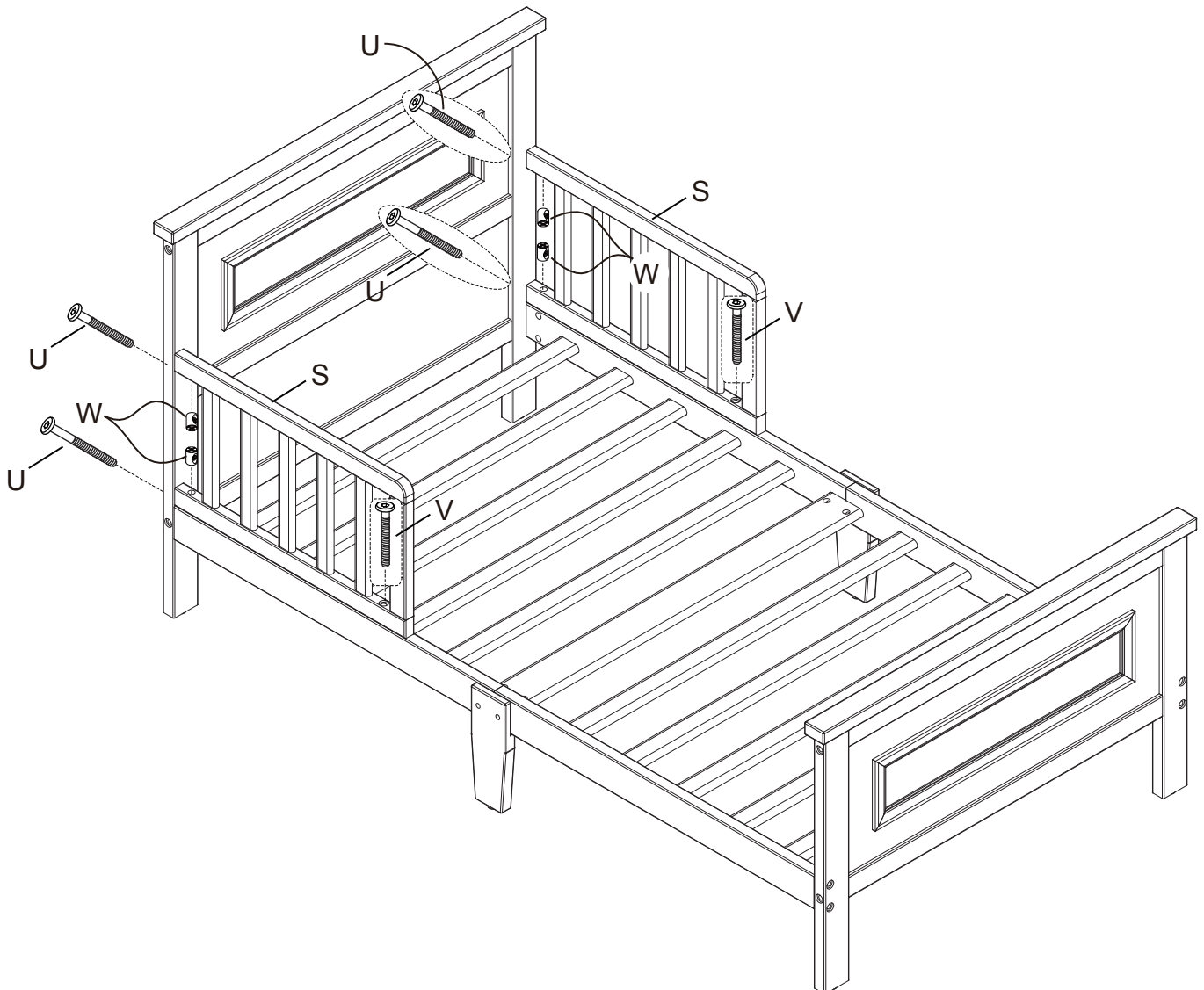



Children's Products

Consumer Care:

www.DeltaChildren.com

Delta Children's Products

114 West 26th Street

New York, NY 10001

Tele.212-645-9033

Warranty: This Delta product is warranted to be free from defects for a period of 90 days from the date of purchase under normal use. This warranty extends only to the original retail purchaser and is valid only when supplied with proof of purchase, or if received as a gift, when the registration is on file with Delta.

To register your product for important safety alerts and updates to your product please visit **www.DeltaChildren.com**

Please do not return this item to the store before contacting us about missing parts or with any questions.

To report a problem, please log on to **www.DeltaChildren.com** and click the Consumer Care Tab, or contact us by phone at (212) 645-9033.

In the event that you need to contact our customer service department please have the Style Number and Lot Number available. Use the space below to make note of those numbers. They can be found on the label on the Headboard bottom rail.

STYLE No: 7148

COLOR

REV

FTY

Lot No. : _____

Pack Date: _____

Date of Purchase: _____ (you should also keep your receipt)