

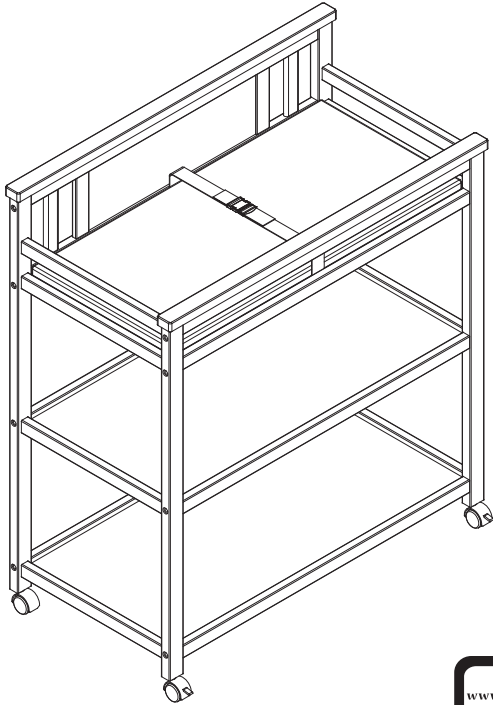

Read all instructions before assembly and use.  
**KEEP INSTRUCTIONS FOR FUTURE USE.**

**⚠ ADULT ASSEMBLY REQUIRED**  
Due to the presence of small parts during assembly, keep out of reach of children until assembly is complete.

## Changing Table



**Consumer Care:**  
[www.DeltaChildren.com](http://www.DeltaChildren.com)  
Delta Children's Products  
114 West 26th Street  
New York, NY 10001  
Tele.212-645-9033

**THIS PRODUCT IS NOT INTENDED FOR  
INSTITUTIONAL OR COMMERCIAL USE.**



Style #: \_\_\_\_\_  
Lot: \_\_\_\_\_  
Date: \_\_\_\_\_



When contacting Delta Consumer Care please reference the above information. Before contacting Delta Consumer Care please ensure that the information above matches the information found on the label on the Top Shelf, please reference the information found on the product when contacting Delta Consumer Care.

To register your product for important safety alerts and updates to your product please visit [www.DeltaChildren.com](http://www.DeltaChildren.com) and click on Product Registration.

## **⚠WARNING**

FALL HAZARD - to prevent death or serious injury, always keep child within arm's reach.

Read all instructions before use of the changing table.

KEEP THESE INSTRUCTIONS IN A SAFE PLACE FOR FUTURE USE.

Inspect the changing table periodically. **Do not** use the changing table if it is damaged or broken. Contact Delta Children's Products with any questions.

Tighten all loose screws and bolts before each use.

The maximum recommended weight of the child is 30lbs for the changing table.

Use only the pad provided by Delta Children's Products.

### **NOTES ON ASSEMBLY:**

-During the assembly process whenever using screws or bolts, check each by placing the screw/bolt on the diagram of the item which is drawn actual size and design. Be sure to use the proper size and shape specified in the instructions.

-To assemble this unit you may be required to place the unit on it's side and face. It is strongly recommended that assembly is done on a soft, non-abrasive surface to avoid damaging the finish.

### **NOTES ON USE:**

Keep children and others safe by following these simple rules:

- **Do not** allow any child to play on furniture
- **Do not** allow climbing on any piece of furniture.
- **Do not** allow hanging from any piece of furniture.
- Always monitor your child's activity when in the nursery.

### **NOTES ON CARE AND MAINTENANCE:**

- **Do not** scratch or chip the finish.
- Inspect the product periodically, contact Delta Children's Products for replacement parts or questions.
- **Do not** store the product or any parts in extreme temperatures and conditions such as a hot attic or a damp, cold basement. These extremes can cause a loss of structural integrity.
- To preserve the luster of the high quality finish on your product, it is recommended to place a doily or felt pad under any items you place on the finish.
- Clean with a damp cloth, then a dry cloth to preserve the original luster and beauty of this fine finish.
- Do not** use abrasive chemicals.
- Do not** spray cleaners directly onto furniture.
- Lift slightly when moving on carpeting to prevent leg breakage.
- Use of a vaporizer near furniture will cause wood to swell and finish to peel.

**PARTS:** MAKE SURE THAT ALL PRE-ASSEMBLED PARTS ARE TIGHT.

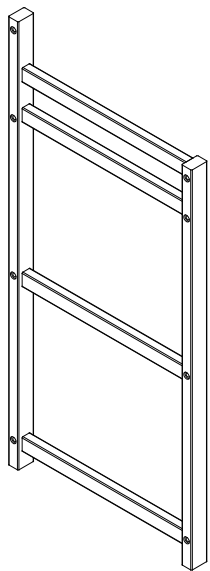

A. Left Side x 1  
Part # 24236

B. Right Side x 1  
Part # 24237

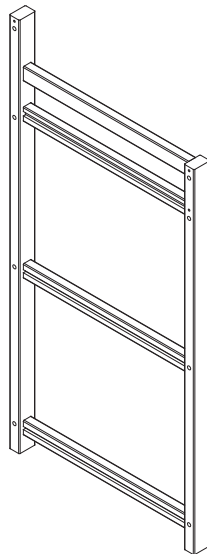

C. Cap Rail x 2  
Part # 21275

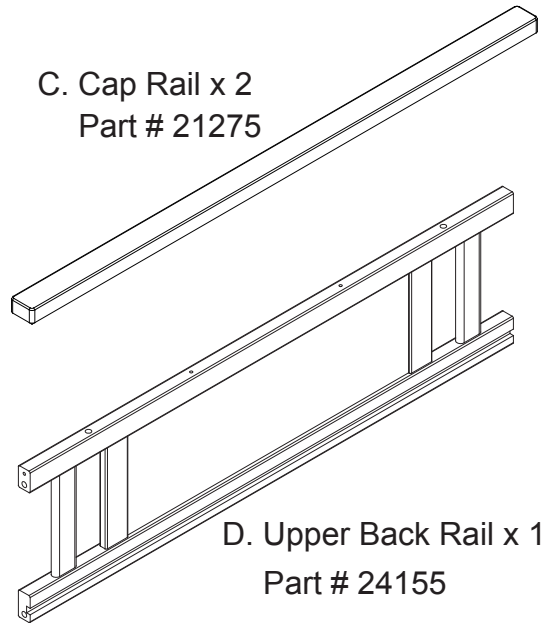

D. Upper Back Rail x 1  
Part # 24155

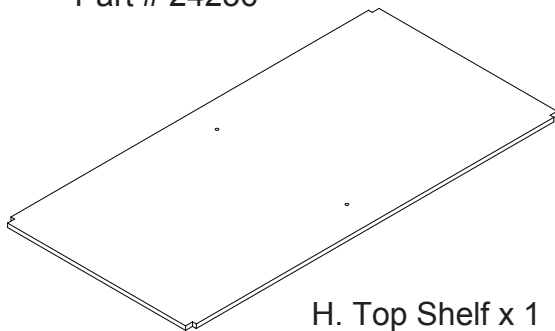
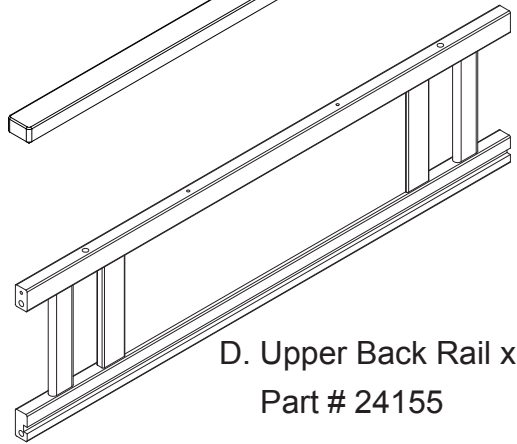

H. Top Shelf x 1  
Part # 21280

E. Top Front Rail x 1  
Part # 21277

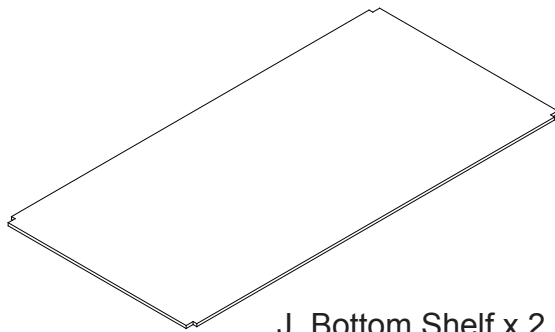
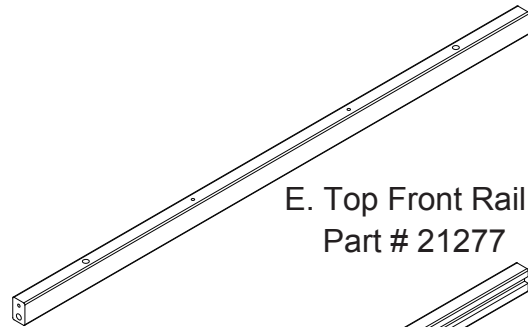

J. Bottom Shelf x 2  
Part # 21281

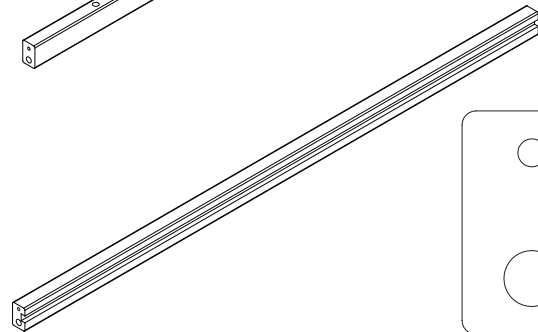

F. Middle Front Rail x 1  
Part # 24290

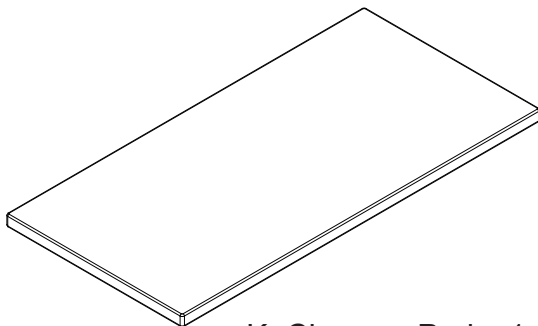
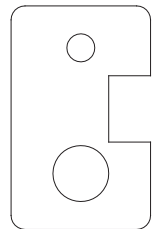

K. Changer Pad x 1  
Part # 21282

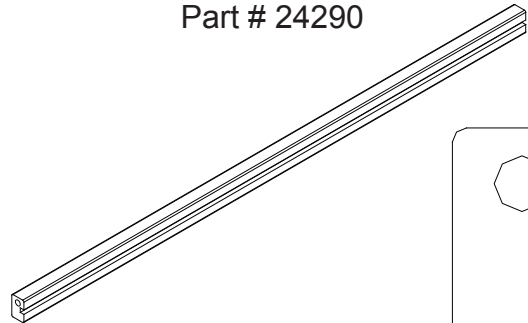

G. Bottom Rail x 4  
Part # 21279

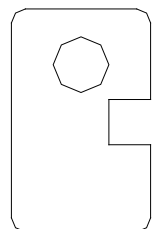

L. Restraint Harness x 1  
Part # 21748

**PARTS:** HARDWARE KIT IS PART #24156-986 FOR COLOR 108 OR #24156-988 FOR COLOR 207. SEE FRONT COVER.

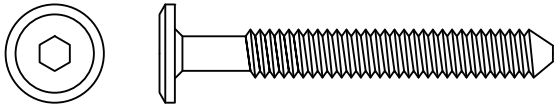

M. M6 x 50 mm Bolt x 16  
Part # 5467

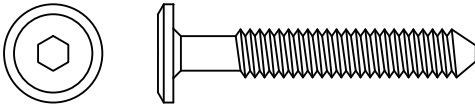

N. M6 x 40 mm Bolt x 4  
Part # 5465

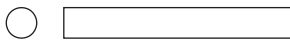

P. Φ4x30 mm Metal Pin x 10  
Part # 5493



R. Nylon Washer x 4  
Part # 5525

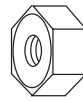

S. Nut x 2  
Part # 4065

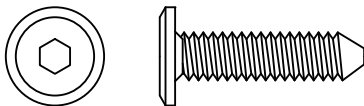

T. M6 x 25 mm Bolt x 2  
Part # 5462

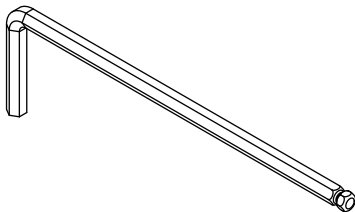

M4 Allen Wrench Supplied  
Part # 1177

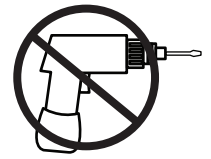

No drills necessary.  
Do not use power  
screwdriver.

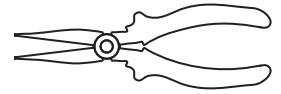

Pliers or Adjustable  
Wrench Required  
for Assembly  
(not supplied)

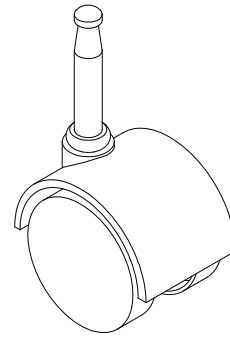

V. Free Caster x 2

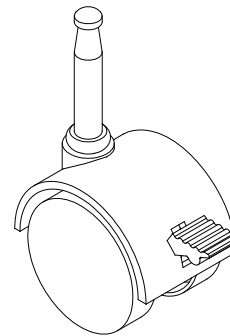

W. Locking Caster x 2

# Section 1: Changing Table Assembly

## Step 1

Parts and tools required to complete step.

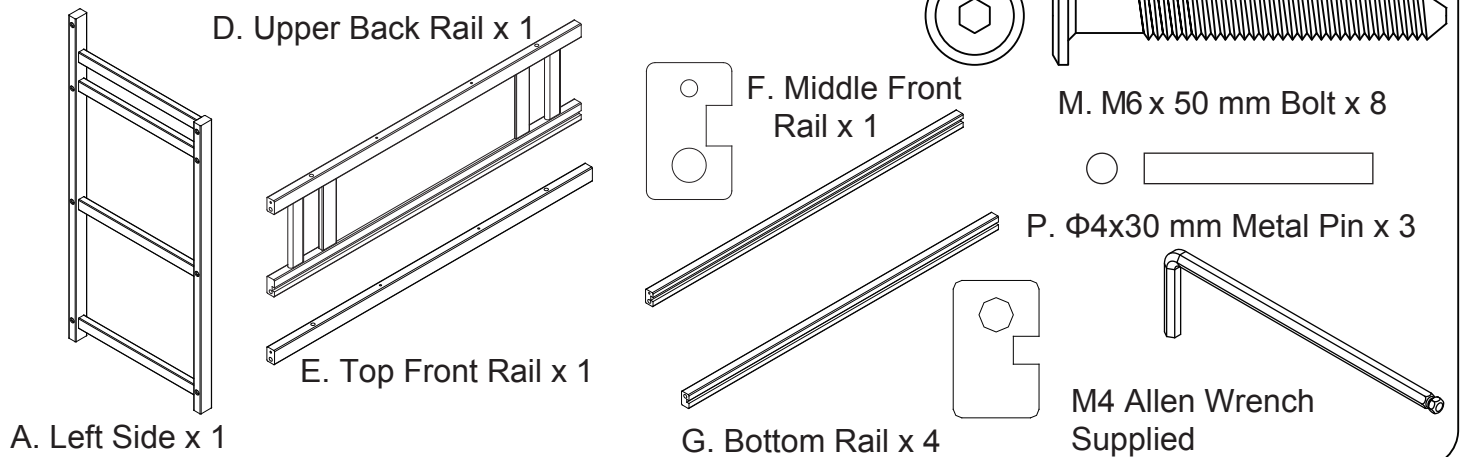

Attach (1) Upper Back Rail (Part D), (1) Top Front Rail (Part E), (1) Middle Front Rail (Part F) and (4) Bottom Rails (Part G) to the Left Side (Part A) with (3)  $\Phi$ 4x30 mm Metal Pins (Part P) and (8) M6x50mm Bolts (Part M) using the M4 Allen Wrench as shown. **BE SURE THE GROOVES FACE TO THE INSIDE.**

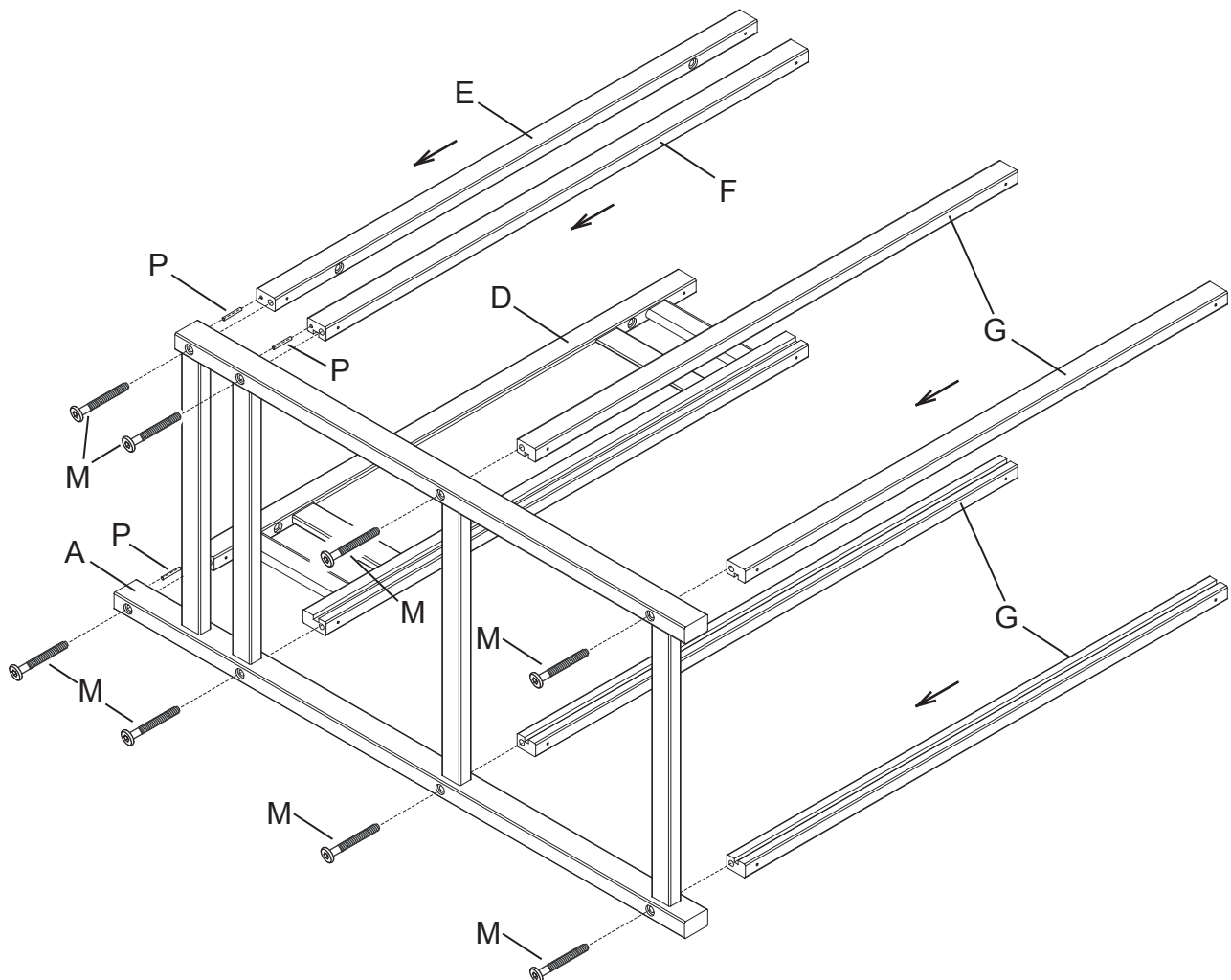

# Section 1: Changing Table Assembly

## Step 2

Parts and tools required to complete step.

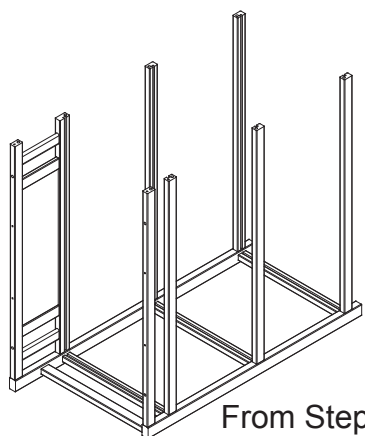

From Step 1

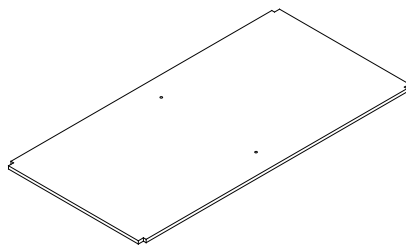

H. Top Shelf x 1

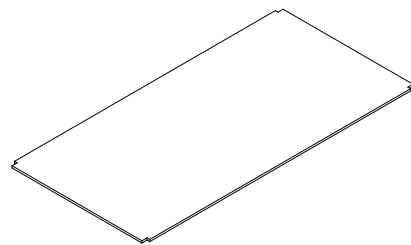

J. Bottom Shelf x 2

Lay the Left Side on the floor, rails up. Slide the Top Shelf (Part H) in the grooves on the Middle Front Rail and Upper Back Rail, into the groove on the Left Side, Slide (2) Bottom Shelves (Part J) in the grooves on the Bottom Rails, into the grooves on the Left Side as shown.

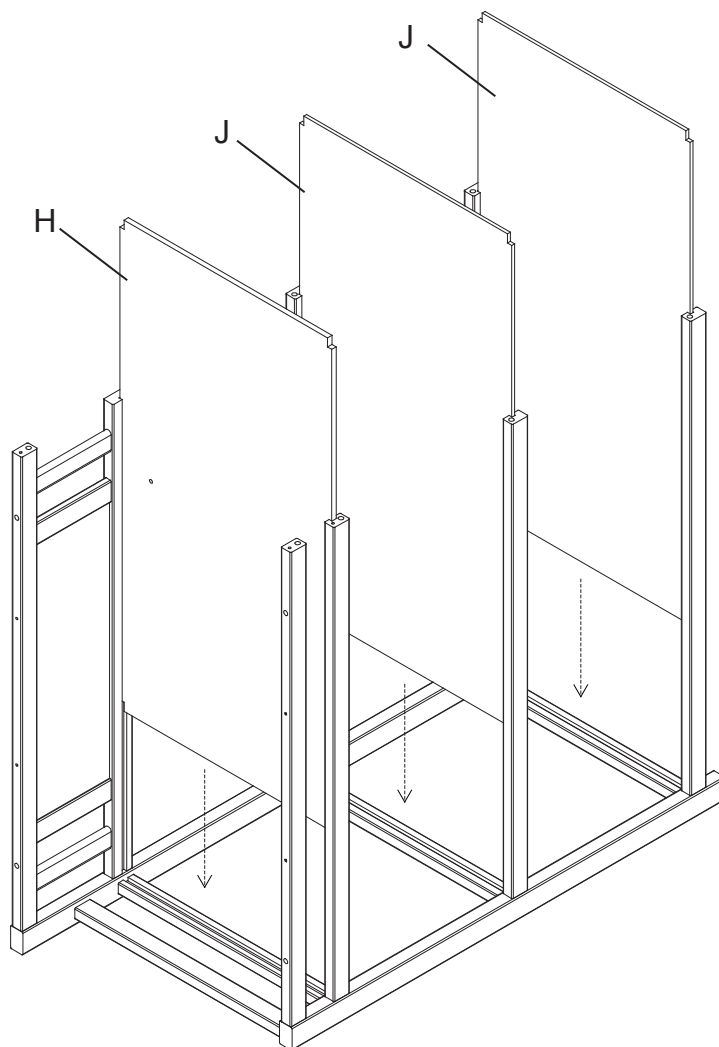

# Section 1: Changing Table Assembly

## Step 3

Parts and tools required to complete step.

From Step 2

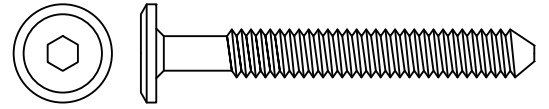
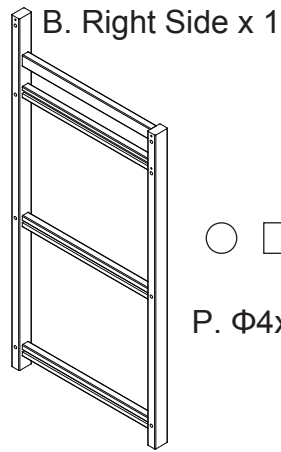
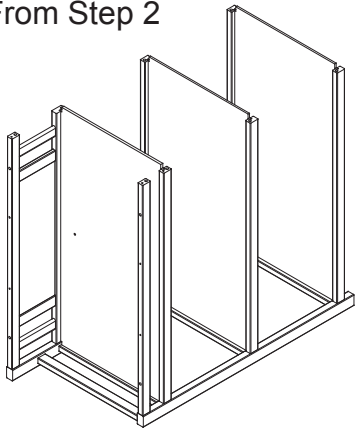

M. M6 x 50 mm Bolt x 8



P.  $\Phi 4 \times 30$  mm Metal Pin x 3

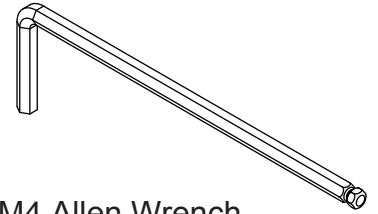

M4 Allen Wrench  
Supplied

Attach (1) Right Side (Part B) to the assembly from step 2 with (3)  $\Phi 4 \times 30$  mm Metal Pins (Part P) and (8) M6x50 mm Bolts (Part M) using the M4 Allen Wrench as shown.

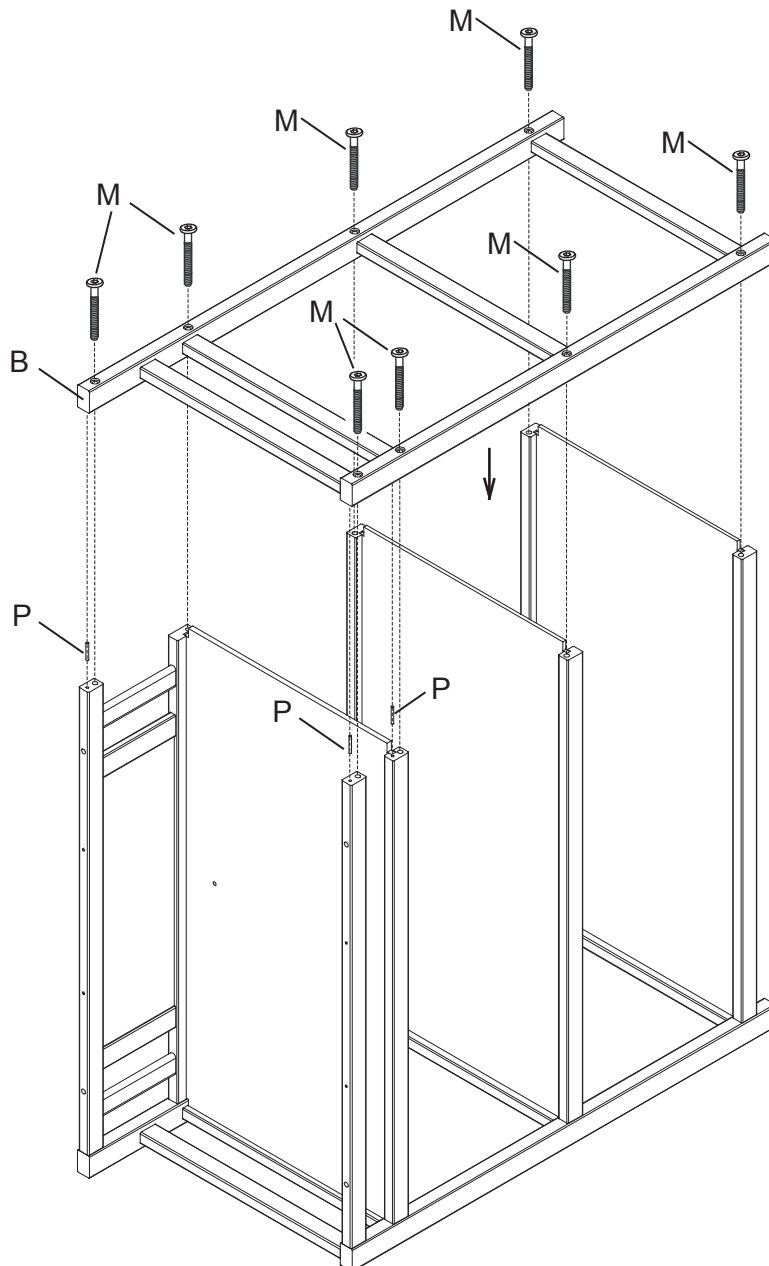

# Section 1: Changing Table Assembly

## Step 4

Parts and tools required to complete step.

From Step 3

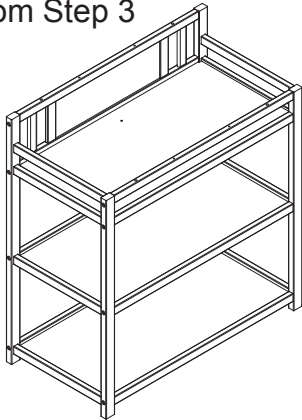

C. Cap Rail x 2

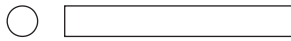
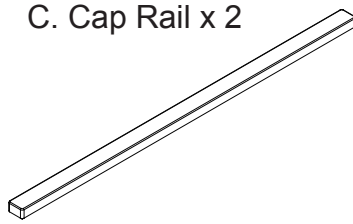

P.  $\Phi 4 \times 30$  mm Metal Pin x 4

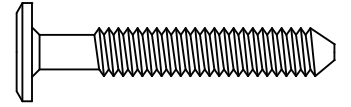
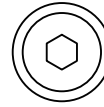

N. M6x40 mm Bolt x 4

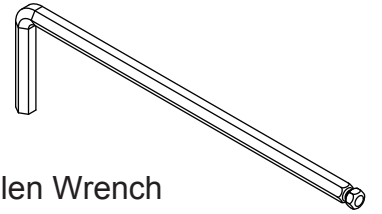

M4 Allen Wrench  
Supplied

Attach (2) Cap Rails (Part C) to the assembly from step 3 with (4)  $\Phi 4 \times 30$  mm Metal Pins (Part P) and (4) M6x40 mm Bolts (Part N) using the M4 Allen Wrench as shown.

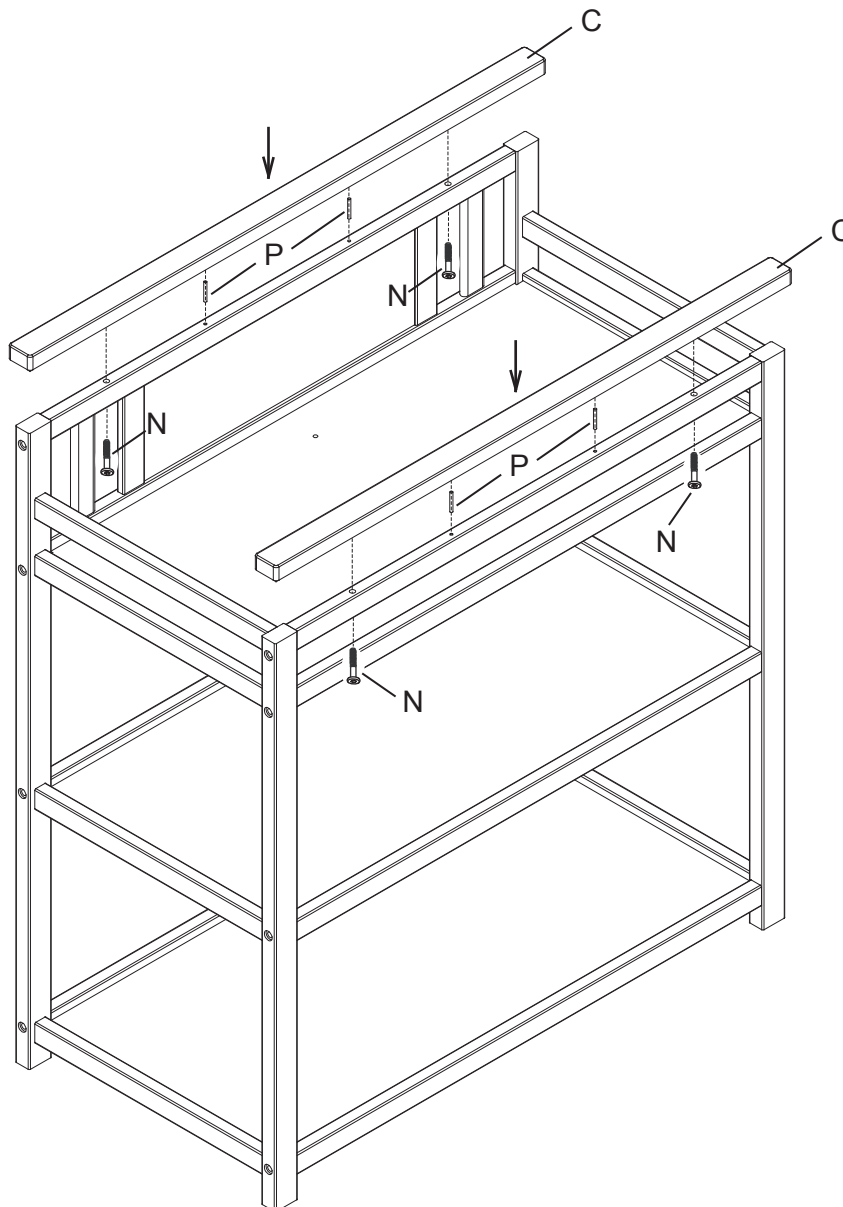



# Section 1: Changing Table Assembly

## Step 5

Parts and tools required to complete step.

From Step 4

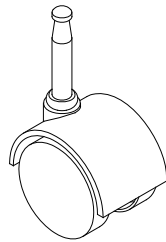
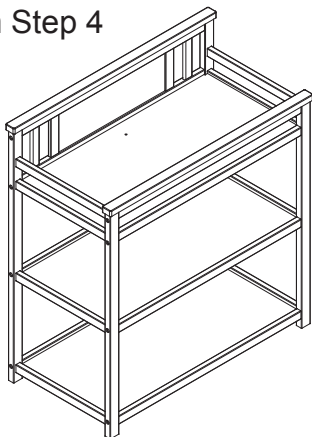

V. Caster x 2

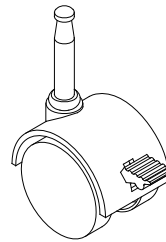

W. Locking Caster x 2

Insert the (2) Casters (Part V) into the Back Legs of the Changing Table. Insert the (2) Locking Casters (Part W) into the Front Legs. Attach each Caster by pressing firmly until it “Snaps” into place. Do not insert the Casters by pounding the ends of the Changing Table on the floor, this will damage the unit.

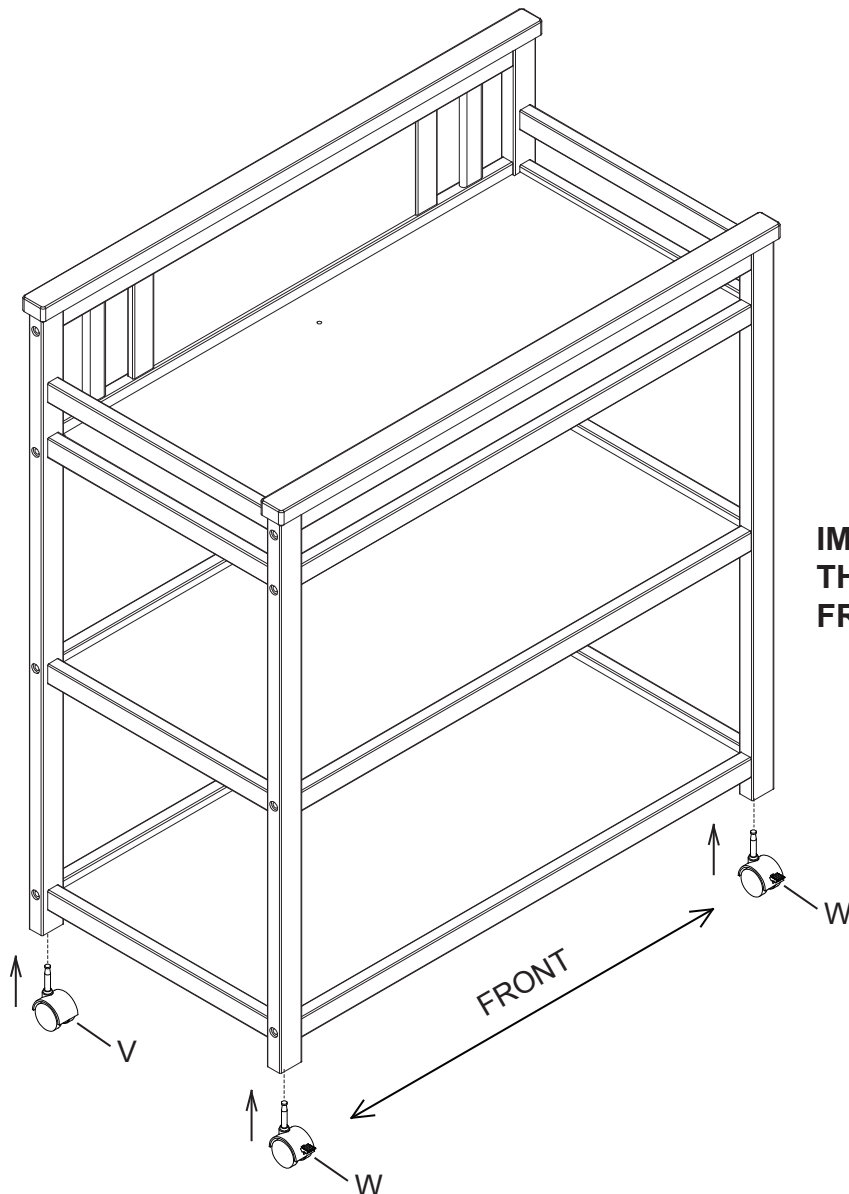

**IMPORTANT: MAKE SURE TO PUT THE LOCKING CASTERS ON THE FRONT OF THE CHANGING TABLE.**

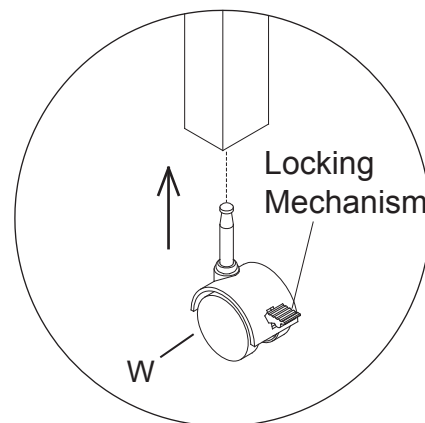

# Section 1: Changing Table Assembly

## Step 6

Parts and tools required to complete step.

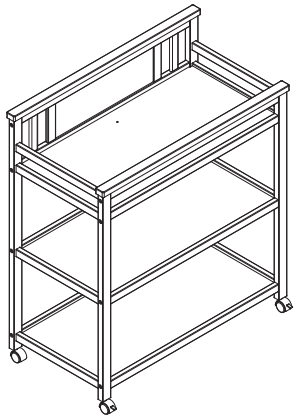

From Step 5



R. Nylon Washer x 4



S. Nut x 2

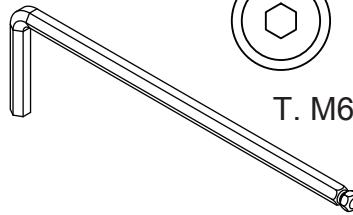

M4 Allen Wrench Supplied

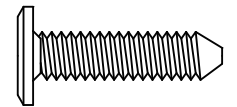
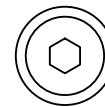

T. M6 x 25 mm Bolt x 2



L. Restraint Harness x 1

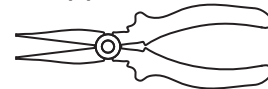

Pliers or Adjustable Wrench (Not Supplied)

Align the hole in the end of the strap of the Restraint Harness (Part L) with the hole in the Top Shelf. Insert (1) M6x25 mm Bolts (Part T) through a Nylon Washer (Part R), the Restraint Strap and the hole in the Shelf. Add (1) Nylon Washer (Part R) with a Nut (Part S). Hold the Nut with a Pliers or Adjustable Wrench. Repeat with the other side of the strap as shown.

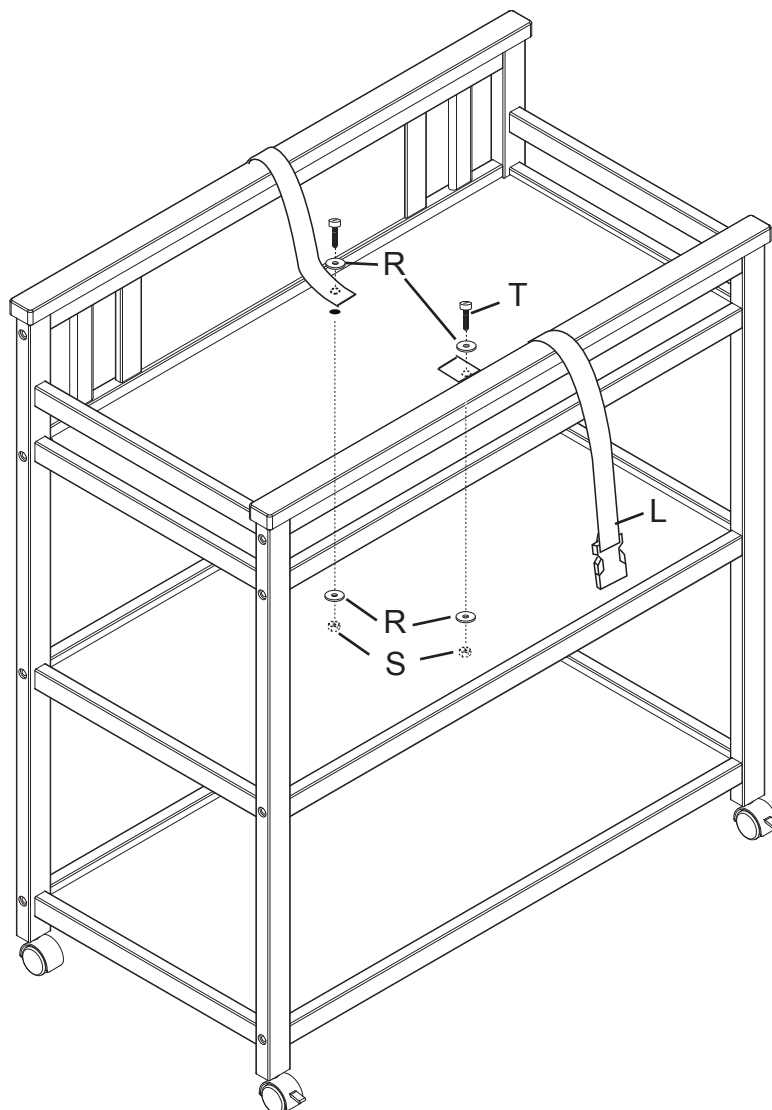

# Section 1: Changing Table Assembly

## Step 7

Parts and tools required to complete step.

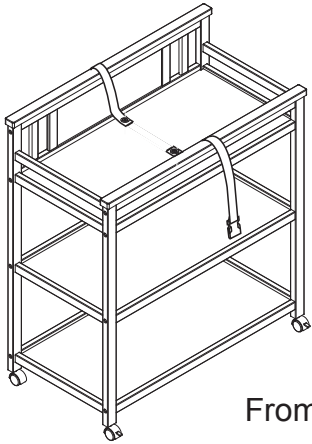

From Step 6

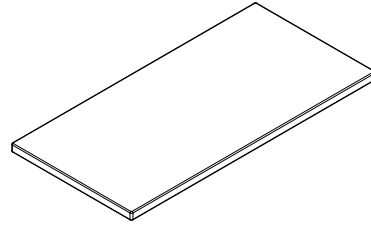

K. Changer Pad x 1

Place the Changer Pad (Part K) onto the Top Shelf (Part H) on top of the attached Strap from step 6, Be sure the buckle on the strap is over the Pad as shown.

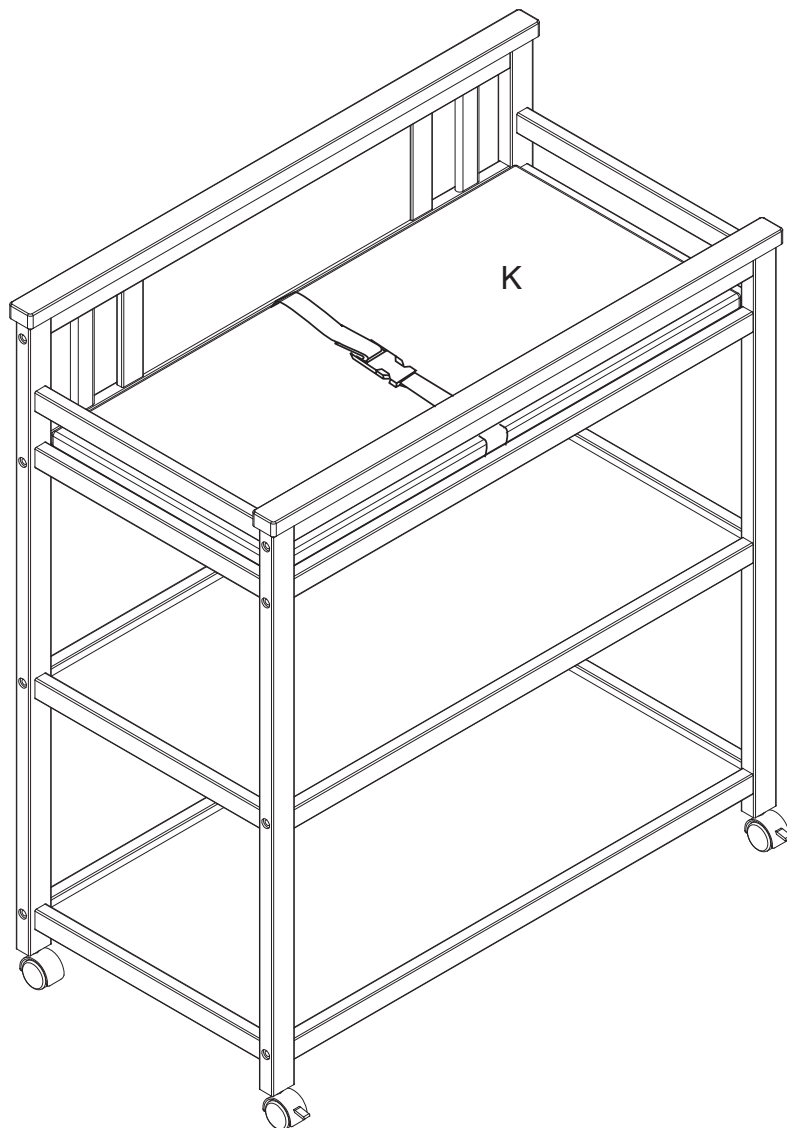

# Section 1: Changing Table Assembly

## Final

### RESTRAINT HARNESS SYSTEM USE:

- . PLACE THE INFANT ON THE CHANGING TABLE FOAM PAD.
- . POSITION THE RESTRAINT HARNESS OVER THE MIDDLE OF THE INFANT'S TORSO AND INSERT THE BUCKLED ENDS INTO EACH OTHER UNTIL THE LOCK SHUT WITH A CLICK.
- . GENTLY PULL THE LOOSE END OF THE STRAP TO LIGHTLY SNUG THE RESTRAINT HARNESS AROUND THE INFANT.

### MAINTENANCE

- . CHECK FASTENERS PERIODICALLY FOR TIGHTNESS. DO NOT OVER TIGHTEN. THIS MAY CAUSE DISTORTION OR BREAKAGE.

**⚠ WARNING : FALL HAZARD**  
**ALWAYS KEEP CHILD WITHIN ARMS REACH.**

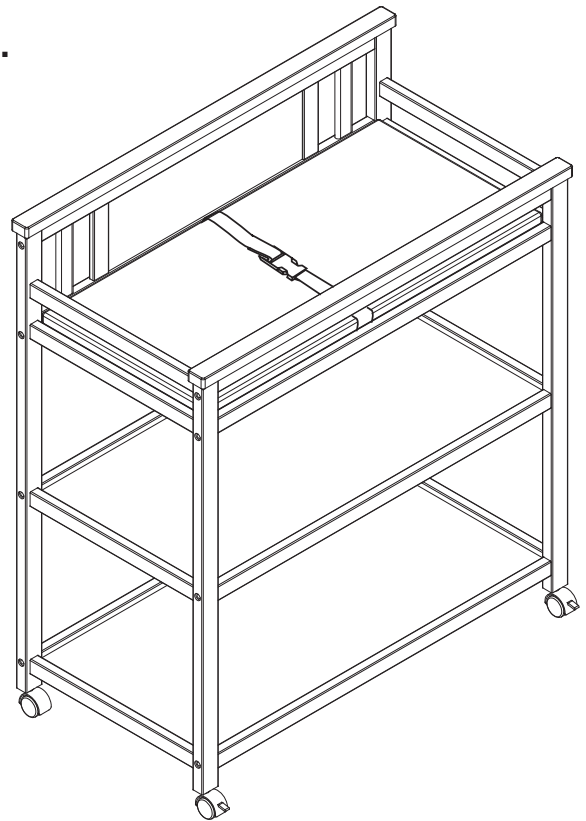
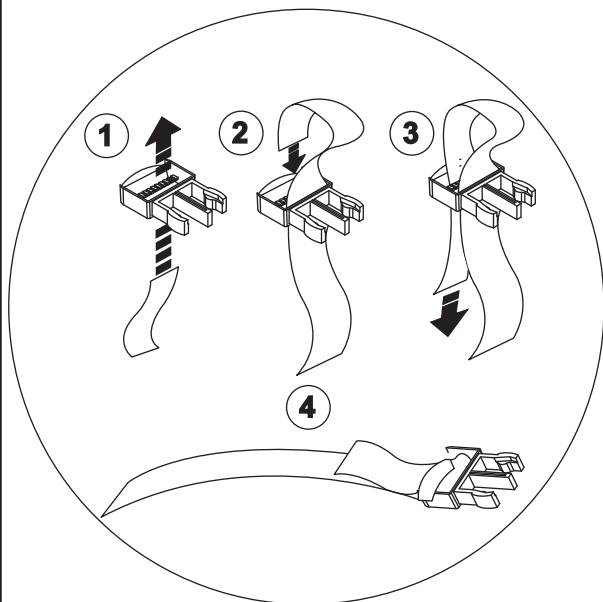

TO FASTEN STRAP - PUSH BUCKLE SIDE TOGETHER  
BE SURE BUCKLE IS FULLY FASTENED TO  
SECURE CHILD SAFELY

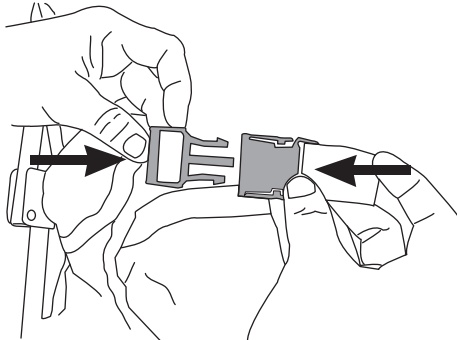

TO RELEASE PRESS BOTH TABS AND PULL APART

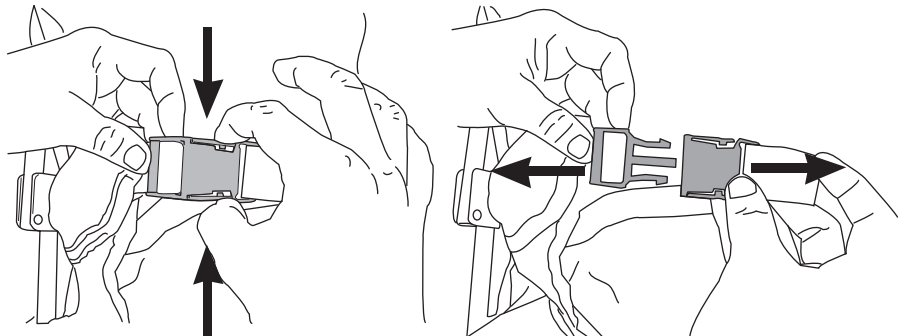



Consumer Care:  
[www.DeltaChildren.com](http://www.DeltaChildren.com)  
Delta Children's Products  
114 West 26th Street  
New York, NY 10001  
Tele.212-645-9033

**Warranty:** This Delta product is warranted to be free from defects for a period of 90 days from the date of purchase under normal use. This warranty extends only to the original retail purchaser and is valid only when supplied with proof of purchase, or if received as a gift, when the registration is on file with Delta.

To register your product for important safety alerts and updates to your product please visit [www.DeltaChildren.com](http://www.DeltaChildren.com)

Please do not return this item to the store before contacting us about missing parts or with any questions.

To report a problem, please log on to [www.DeltaChildren.com](http://www.DeltaChildren.com) and click the Consumer Care Tab, or contact us by phone at (212) 645-9033.

In the event that you need to contact our customer service department please have the Style Number and Lot Number available. Use the space below to make note of those numbers. They can be found on the label on the Top Shelf.

**STYLE No: 7542**

COLOR

REV

FTY

Lot No. : \_\_\_\_\_

Pack Date: \_\_\_\_\_

Date of Purchase: \_\_\_\_\_ (you should also keep your receipt)