

Delta™

Children's Products

Glider N Ottoman

Read all instructions before assembly and use.
KEEP INSTRUCTIONS FOR FUTURE USE.

⚠ ADULT ASSEMBLY REQUIRED

Due to the presence of small parts during assembly, keep out of reach of children until assembly is complete.

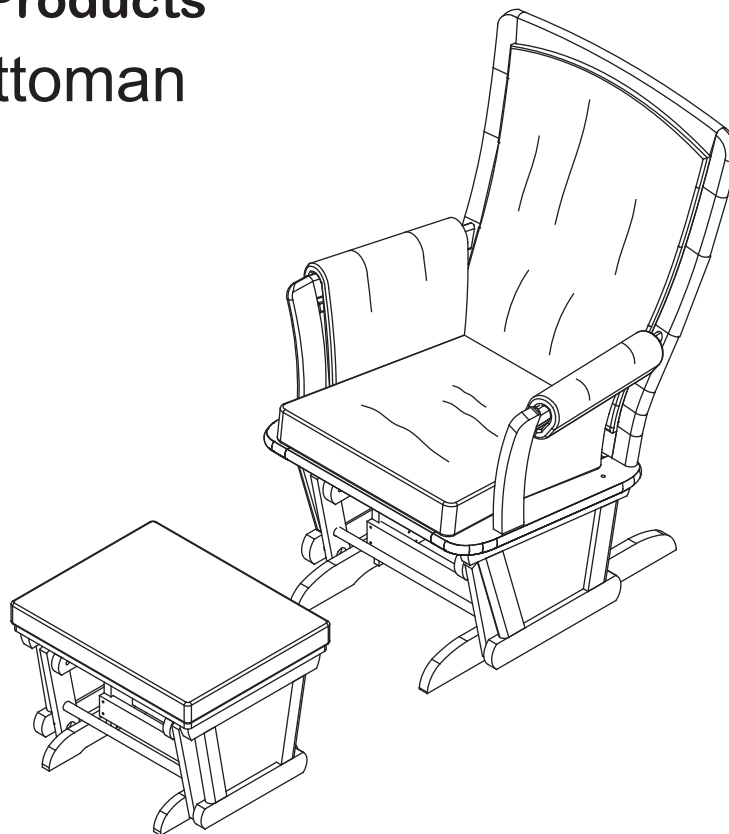

THIS PRODUCT IS NOT INTENDED FOR INSTITUTIONAL OR COMMERCIAL USE.

Consumer Care:

www.DeltaChildren.com

Delta Children's Products

114 West 26th Street

New York, NY 10001

Tele.212-645-9033

Style #: _____

Lot: _____

Date: _____



When contacting Delta Consumer Care you will need to reference the above numbers. They can also be found on the label on the bottom of Chair Back.

To register your product for important safety alerts and updates to your product please visit www.DeltaChildren.com and click on Product Registration.

PARTS: MAKE SURE THAT ALL PRE-ASSEMBLED PARTS ARE TIGHT.



A. GLIDER BACK FRAME (1)

B. LEFT GLIDER ARM (1)

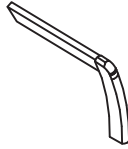

C. RIGHT GLIDER ARM (1)

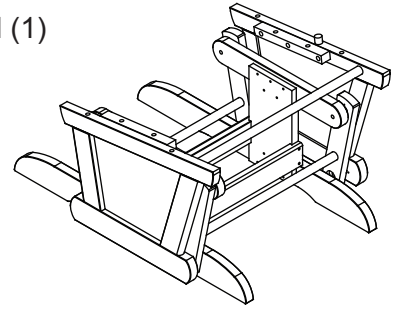
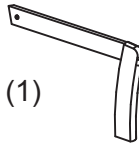

D. GLIDER BASE (1)

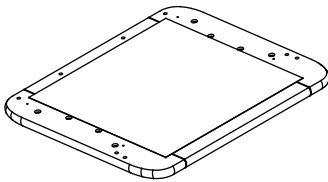

E. GLIDER SEAT (1)



F. LEFT GLIDER ARM CUSHIONS (1)

G. RIGHT GLIDER ARM CUSHIONS (1)

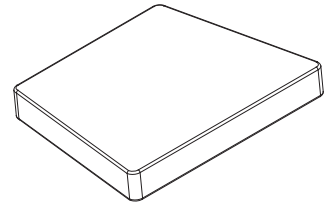

H. GLIDER SEAT CUSHION (1)

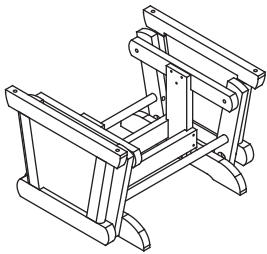

J. OTTOMAN BASE (1)

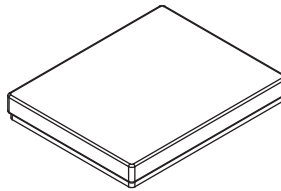

K. OTTOMAN CUSHION (1)



L. BOTTOM GLIDES (4)

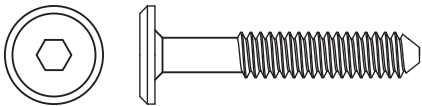

M. 1/4" x 1-3/8" BOLT x 20

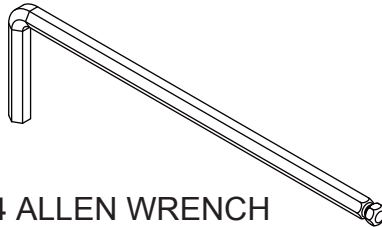

M4 ALLEN WRENCH SUPPLIED

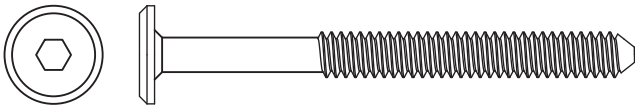

N. 1/4" x 2-1/2" BOLT x 2



P. 1/4" x 1/2" BARREL NUT (2)

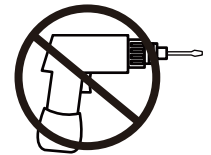

No drills necessary. Do not use power screwdriver.



Flat Head Screwdriver (not supplied)

STEP 1

TURN THE GLIDER BASE (PART D) OVER, THEN ATTACH THE BOTTOM GLIDES (PART L) AS SHOWN. REMOVE THE BLACKING STRIP FROM ONE GLIDE AT A TIME AND ADHERE THE GLIDE TO THE BASE, REPEAT FOR ALL 4 GLIDES.

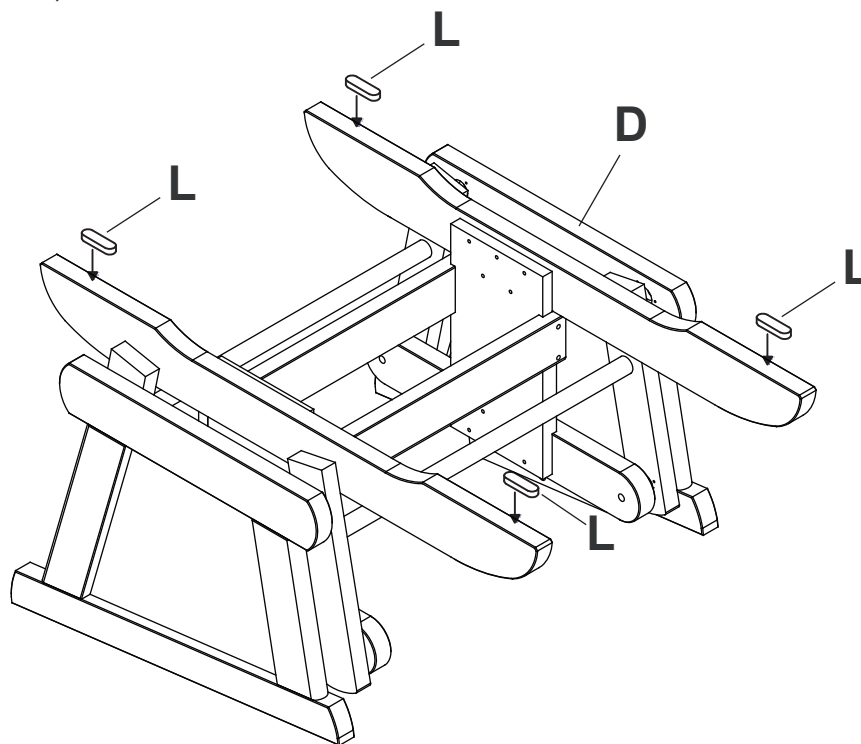

STEP 2

ATTACH THE GLIDER BACK FRAME (PART A) TO THE GLIDER SEAT (PART E) USING (4) 1/4" x 1-3/8" BOLTS (PART M), TIGHTEN WITH THE M4 ALLEN WRENCH.

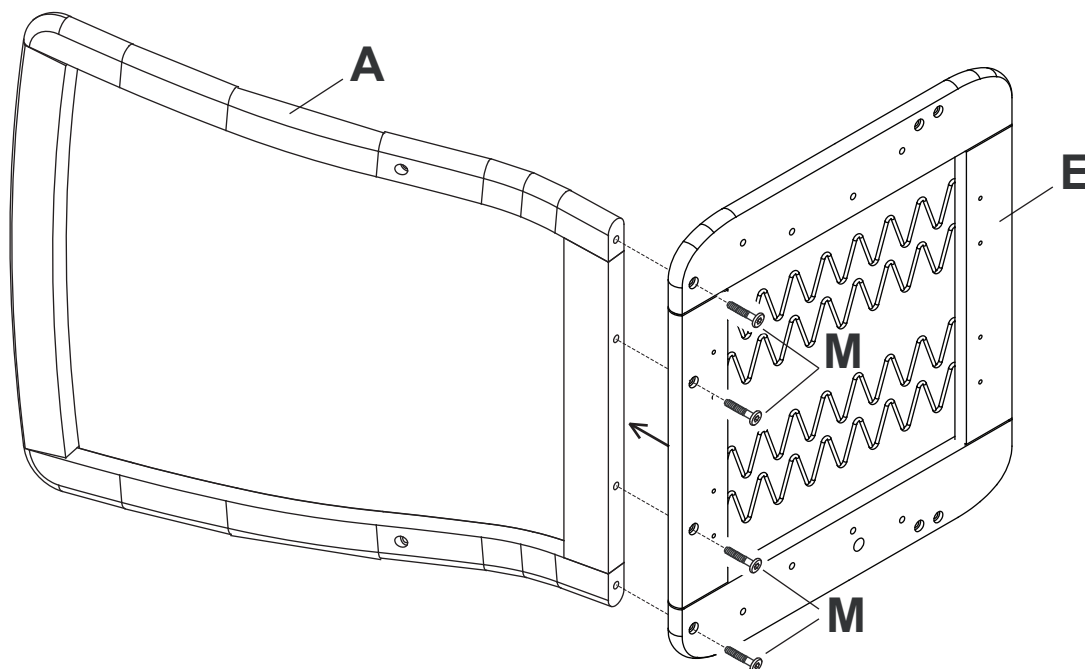

STEP 3

ATTACH THE LEFT GLIDER ARM (PART B) AND THE RIGHT GLIDER ARM (PART C) TO THE GLIDER SEAT USING (2) 1/4" x 1-3/8" BOLTS (PART M) EACH (FIGURE A). **DO NOT TIGHTEN BOLTS.** INSTALL A BARREL NUT (PART P) IN THE HOLE AT THE BACK OF EACH ARM (FIGURE B). INSTALL (2) 1/4" x 2-1/2" BOLTS (PART N) AS SHOWN IN FIGURE C. TIGHTEN ALL BOLTS WITH THE M4 ALLEN WRENCH.

FIGURE A

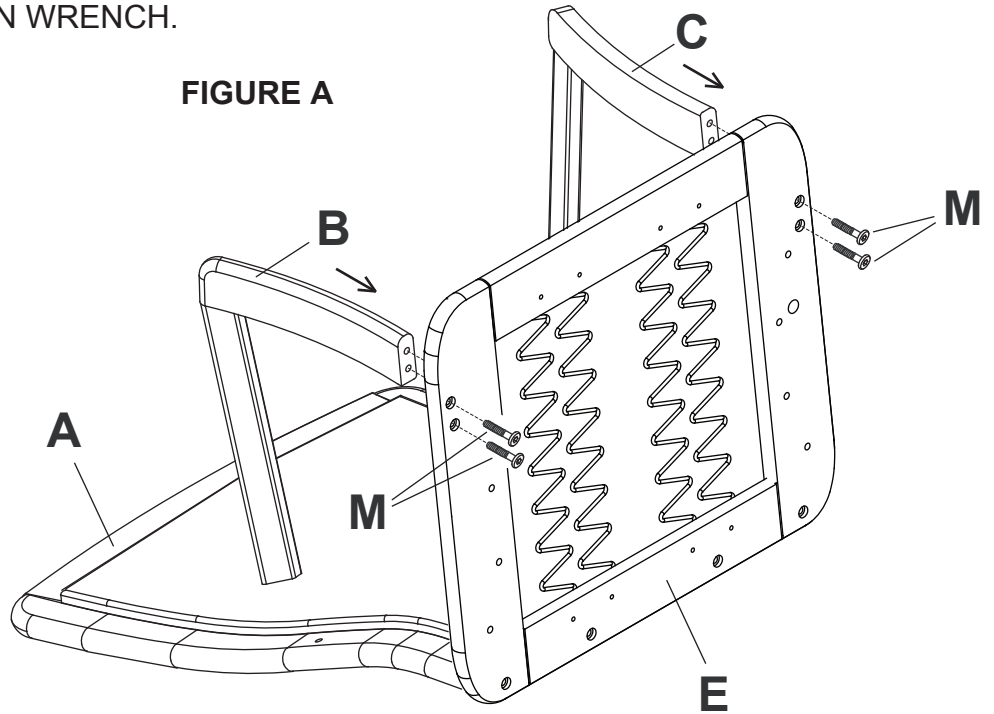

FIGURE B

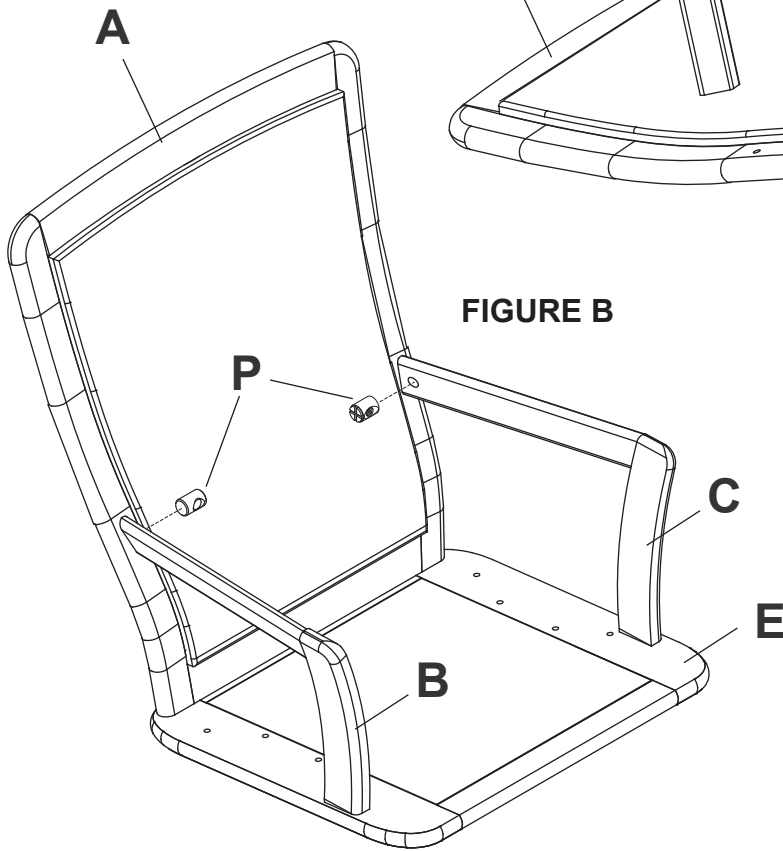
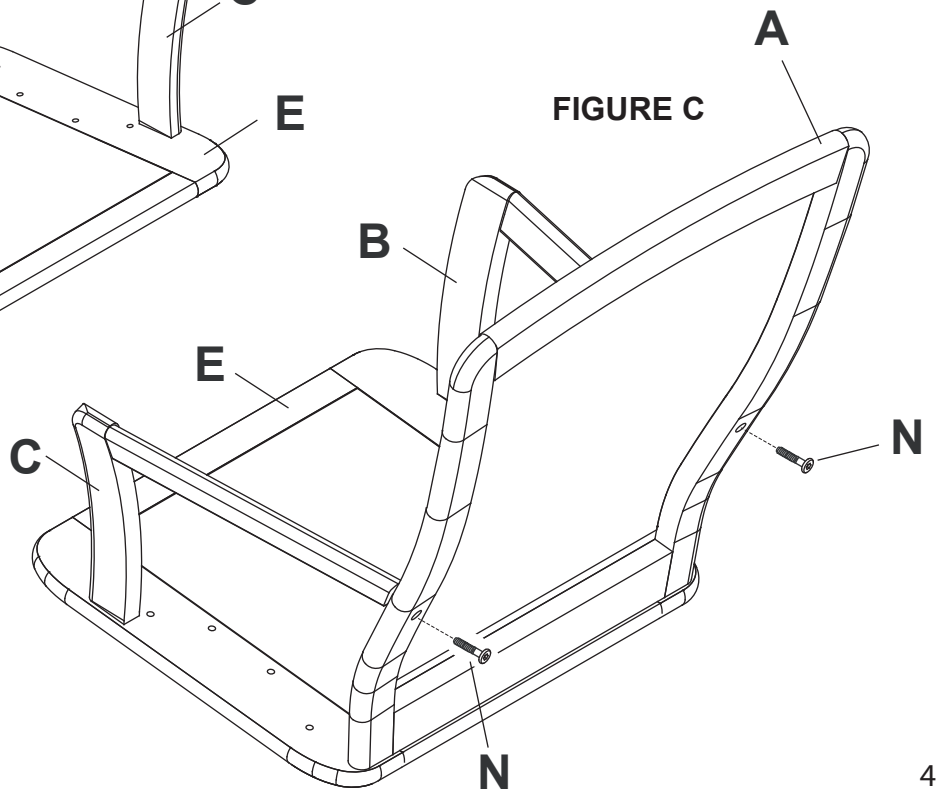

FIGURE C



STEP 4

ATTACH THE ASSEMBLES FROM STEP 3 TO THE GLIDER BASE USING (8) 1/4" x 1-3/8" BOLTS (PART M) AS SHOWN IN FIGURE A & B. TIGHTEN WITH THE M4 ALLEN WRENCH.

FIGURE A

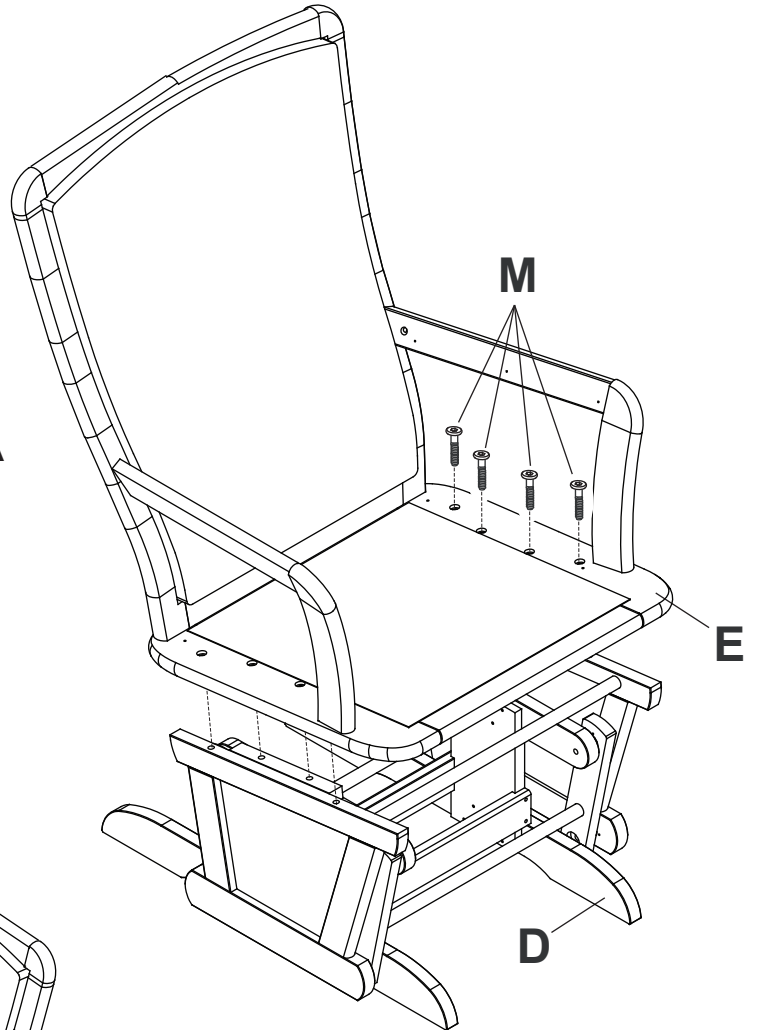
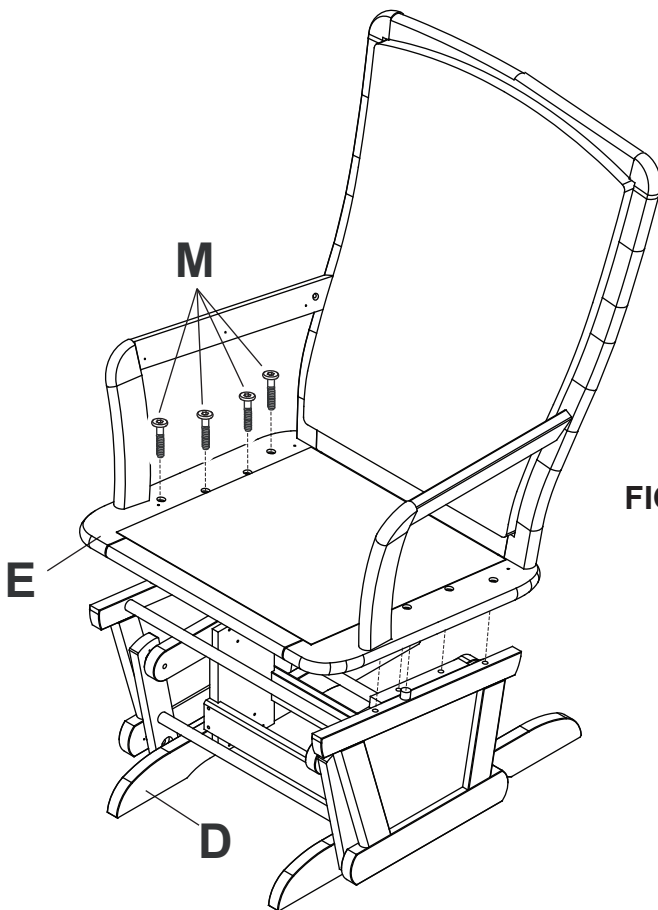
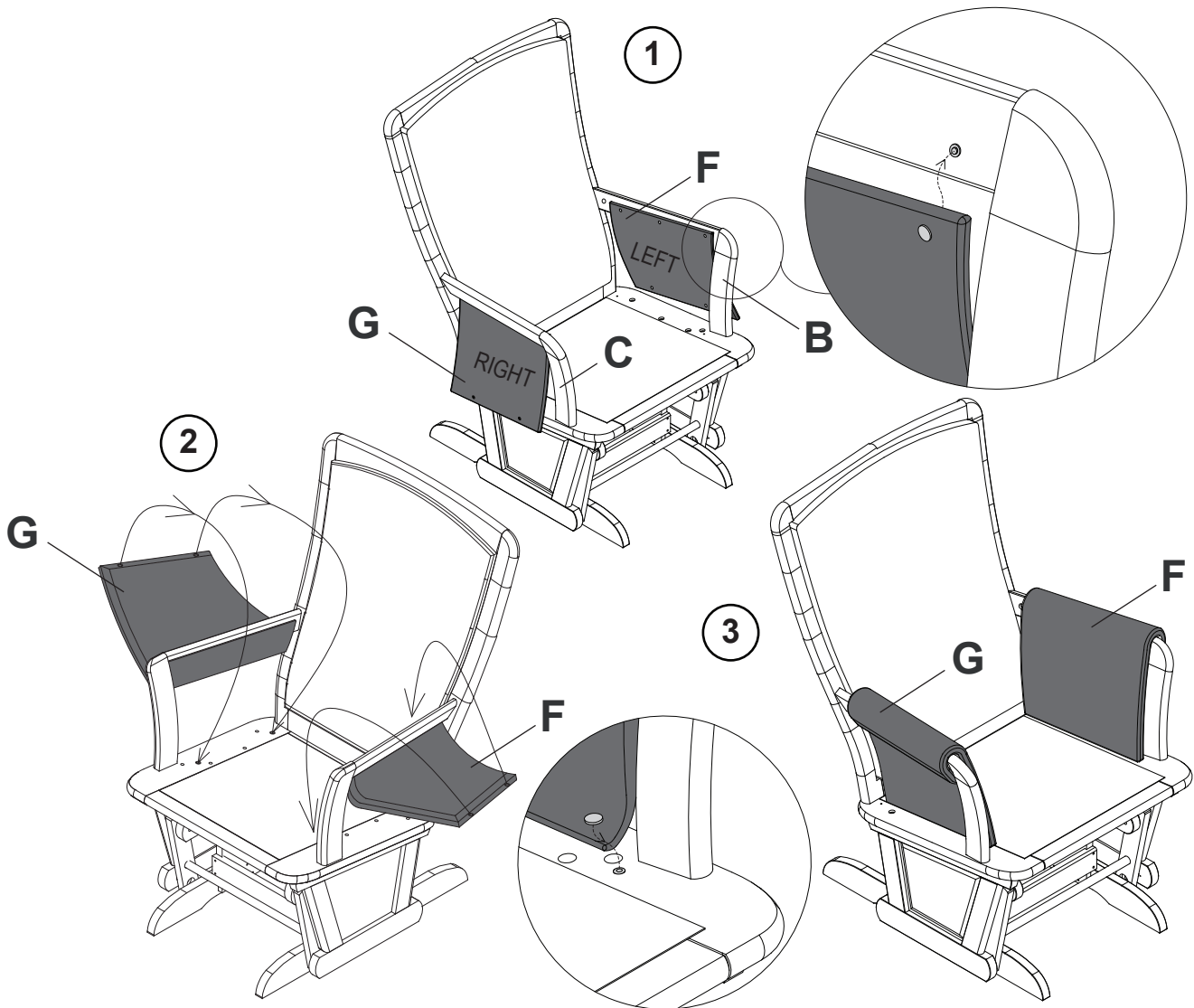

FIGURE B



STEP 5

ATTACH (1) LEFT GLIDER ARM CUSHION (PART F) TO THE LEFT GLIDER ARM. WITH THE SNAPS ON THE GLIDER ARM CUSHION FACING UP, SLIDE THE GLIDER ARM CUSHION UNDER THE GLIDER ARM AND SNAP ALL (3) SNAPS INTO PLACE. FOLD THE GLIDER ARM CUSHION UNDER THE BOTTOM, THEN OVER TOP OF THE GLIDER ARM AS SHOWN. SNAP (2) SNAPS AT THE BOTTOM OF THE GLIDER ARM PAD TO THE GLIDER SEAT. REPEAT ON THE OTHER GLIDER ARM.



STEP 6

ATTACH THE GLIDER SEAT CUSHION (PART H) INTO THE GLIDER AS SHOWN.

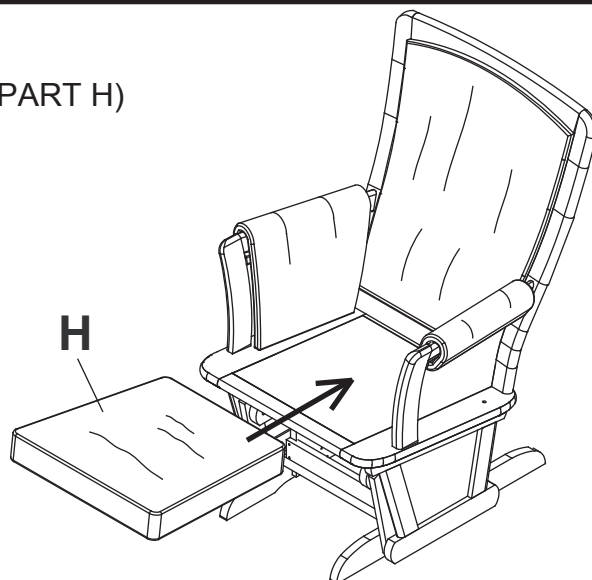

STEP 7

ATTACH THE OTTOMAN CUSHION (PART K) TO THE OTTOMAN BASE (PART J) USING (4) 1/4" x 1-3/8" BOLTS (PART M), TIGHTEN WITH THE M4 ALLEN WRENCH.

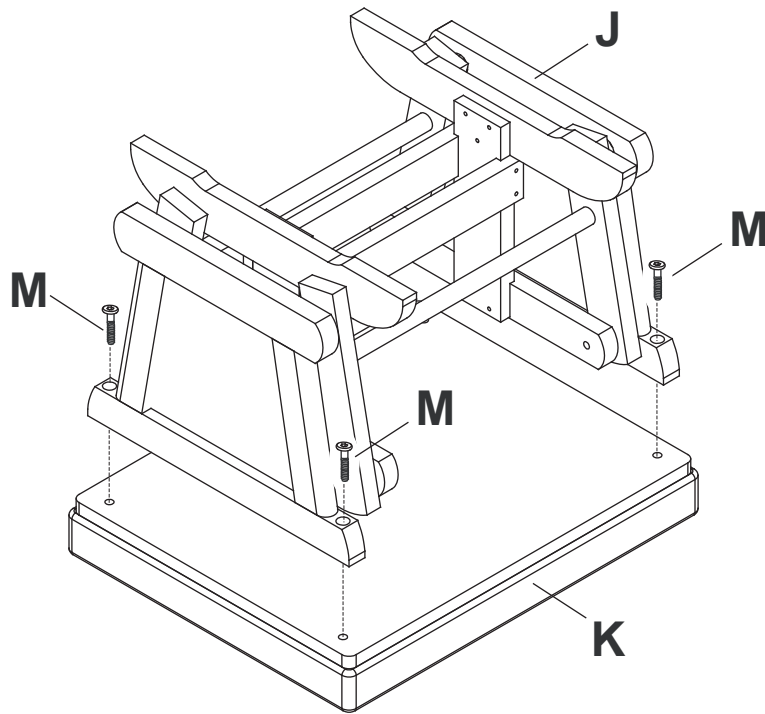

FINAL

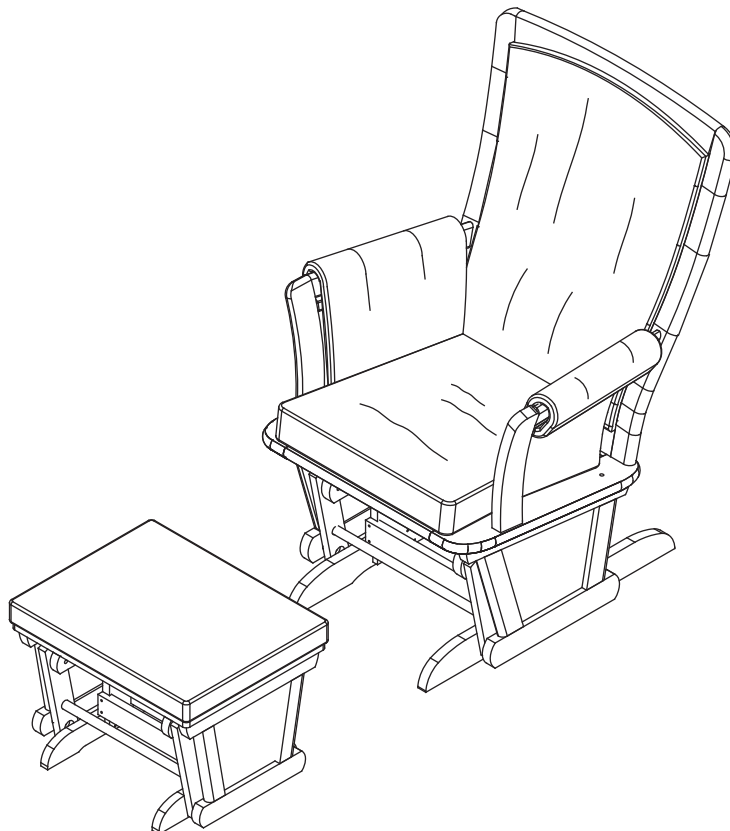



Children's Products

Consumer Care:

www.DeltaChildren.com

Delta Children's Products

114 West 26th Street

New York, NY 10001

Tele.212-645-9033

Warranty: This Delta Glider and Ottoman is warranted to be free from defects for a period of 90 days from the date of purchase under normal use. This warranty extends only to the original retail purchaser and is valid only when supplied with proof of purchase, or if received as a gift, when the registration is on file with Delta.

Please do not return this item to the store before contacting us about missing parts or with any questions. To register your product for important safety alerts and updates to your product please visit www.DeltaChildren.com

To report a problem, please log on to www.DeltaChildren.com and click the Consumer Care Tab, or contact us by phone at (212) 645-9033.

In the event that you need to contact our customer service department please have the Style Number and Lot Number available. Use the space below to make note of those numbers. They can be found on the label on the bottom of Chair Back.

Style Number: _____

Lot No: _____

Pack Date: _____

Date of Purchase: _____ (you should also keep your receipt)

NOTES ON CARE AND MAINTENANCE:

FABRIC CARE INSTRUCTIONS:

- SPOT CLEAN ONLY.
- CLEAN SPOTS AS SOON AS THEY OCCUR WITH A FABRIC SAFE CLEANING PRODUCT.
- FOLLOW ALL WARNINGS AND INSTRUCTIONS ON ANY CLEANING PRODUCT USED.
- **DO NOT** USE BLEACH.
- USE ONLY LINT FREE CLOTHS.
- AIR DRY - **DO NOT** PLACE IN SUN.
- MACHINE WASHING IS NOT RECOMMENDED.

WOOD:

- **DO NOT** SCRATCH OR CHIP THE FINISH.
- INSPECT PERIODICALLY, CONTACT DELTA CHILDREN'S PRODUCTS FOR REPLACEMENT PARTS OR QUESTIONS.
- **DO NOT** STORE ANY PARTS IN EXTREME TEMPERATURES AND CONDITIONS SUCH AS A HOT ATTIC OR A DAMP, COLD BASEMENT. THESE EXTREMES CAN CAUSE A LOSS OF STRUCTURAL INTEGRITY.
- CLEAN WITH A DAMP CLOTH, THEN A DRY CLOTH TO PRESERVE THE ORIGINAL LUSTER AND BEAUTY OF THIS FINE FINISH.
- **DO NOT** USE ABRASIVE CHEMICALS.
- **DO NOT** SPRAY CLEANERS ONTO FURNITURE.
- LIFT SLIGHTLY WHEN MOVING ON CARPETING TO PREVENT LEG BREAKAGE.
- USE OF A VAPORIZER NEAR FURNITURE WILL CAUSE WOOD TO SWELL AND FINISH TO PEEL.