

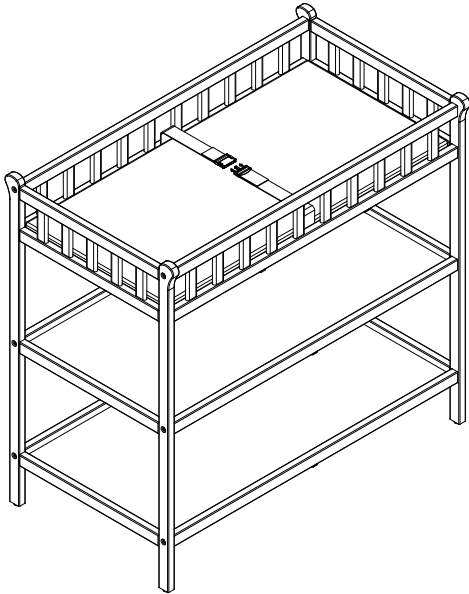

Read all instructions before assembly and use.
KEEP INSTRUCTIONS FOR FUTURE USE.

ADULT ASSEMBLY REQUIRED
Due to the presence of small parts during assembly, keep out of reach of children until assembly is complete.

Changing Table



Need Help?

Please visit www.DeltaChildren.com/assembly-videos to watch our easy and effective assembly videos

Consumer Care:
www.DeltaChildren.com

Delta Children's Products
114 West 26th Street
New York, NY 10001
Tele.212-645-9033

**This product is not intended for institutional or commercial use.
Este producto no esta hecho para uso institucional o comercial.**

Style #: _____
Lot: _____
Date: _____



When contacting Delta Consumer Care please reference the above information. Before contacting Delta Consumer Care please ensure that the information above matches the information found on the label on the Top Shelf, please reference the information found on the product when contacting Delta Consumer Care.

To register your product for important safety alerts and updates to your product please visit www.DeltaChildren.com and click on Product Registration.

⚠ WARNING: Changing Table

⚠ WARNING

FALL HAZARD - to prevent death or serious injury, always keep child within arm's reach. Read all instructions before use of the changing table.

KEEP THESE INSTRUCTIONS IN A SAFE PLACE FOR FUTURE USE.

Inspect the changing table periodically. **Do not** use the changing table if it is damaged or broken. Contact Delta Children's Products with any questions.

Tighten all loose screws and bolts before each use.

The maximum recommended weight of the child is 30lbs for the changing table.

Use only the pad provided by Delta Children's Products.

Always secure the pad to the changing surface by inserting the strap through the hole in the middle of the pad. See Instructions.

NOTES ON ASSEMBLY:

- During the assembly process whenever using screws or bolts, check each by placing the screw/bolt on the diagram of the item which is drawn actual size and design. Be sure to use the proper size and shape specified in the instructions.
- To assemble this unit you may be required to place the unit on it's side and face. It is strongly recommended that assembly is done on a soft, non-abrasive surface to avoid damaging the finish.

NOTES ON USE:

Keep children and others safe by following these simple rules:

- **Do not** allow any child to play on furniture
- **Do not** allow climbing on any piece of furniture.
- **Do not** allow hanging from any piece of furniture.
- Always monitor your child's activity when in the nursery.

NOTES ON CARE AND MAINTENANCE:

- **Do not** scratch or chip the finish.
- Inspect the product periodically, contact Delta Children's Products for replacement parts or questions.
- **Do not** store the product or any parts in extreme temperatures and conditions such as a hot attic or a damp, cold basement. These extremes can cause a loss of structural integrity.
- To preserve the luster of the high quality finish on your product, it is recommended to place a doily or felt pad under any items you place on the finish.
- Clean with a damp cloth, then a dry cloth to preserve the original luster and beauty of this fine finish.
- Do not** use abrasive chemicals.
- Do not** spray cleaners directly onto furniture.
- Lift slightly when moving on carpeting to prevent leg breakage.
- Use of a vaporizer near furniture will cause wood to swell and finish to peel.

PARTS: MAKE SURE THAT ALL PRE-ASSEMBLED PARTS ARE TIGHT.

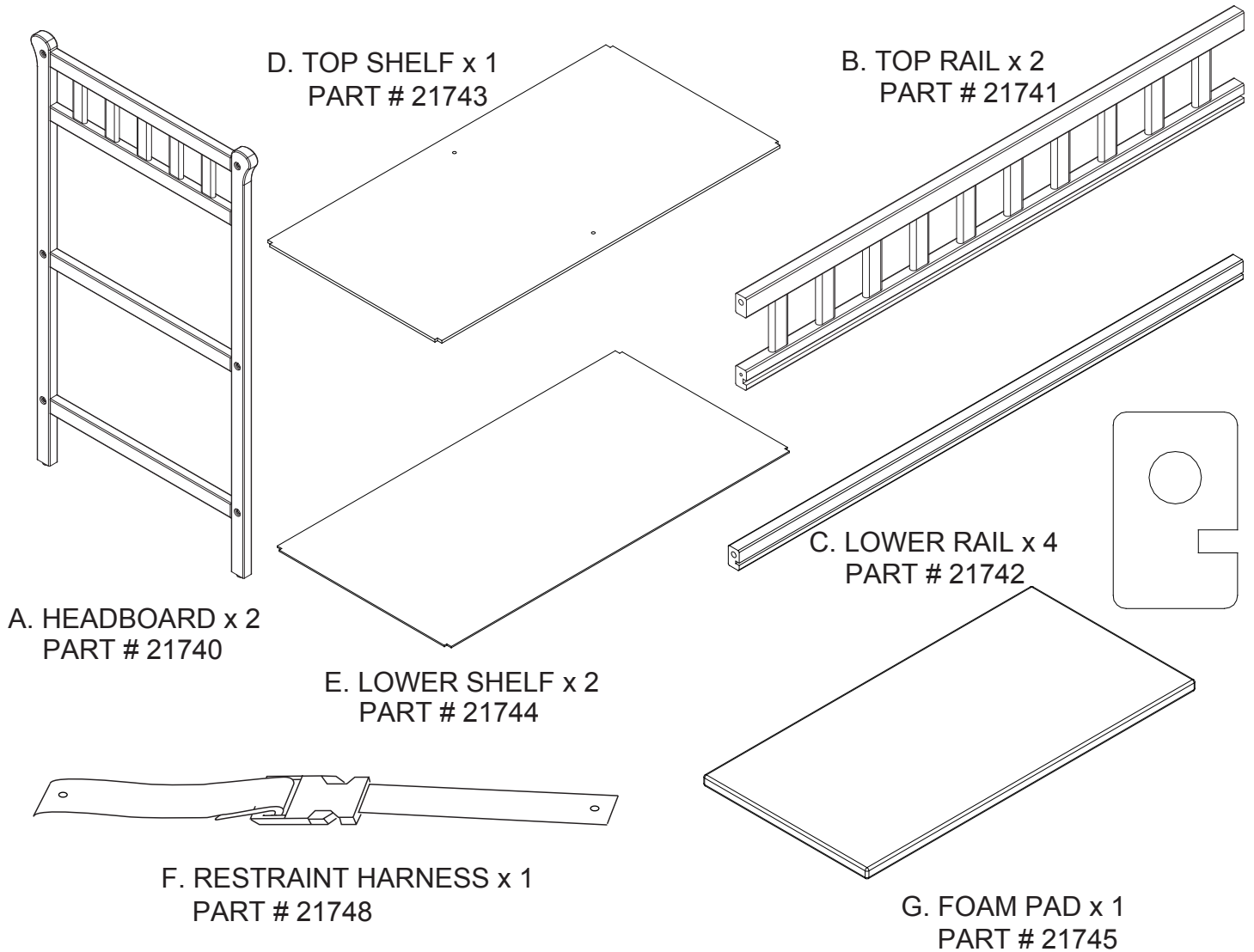

PARTS: HARDWARE KIT IS PART # 21746 FOR COLOR 100 OR # 21750 FOR COLOR 209.
SEE FRONT COVER.

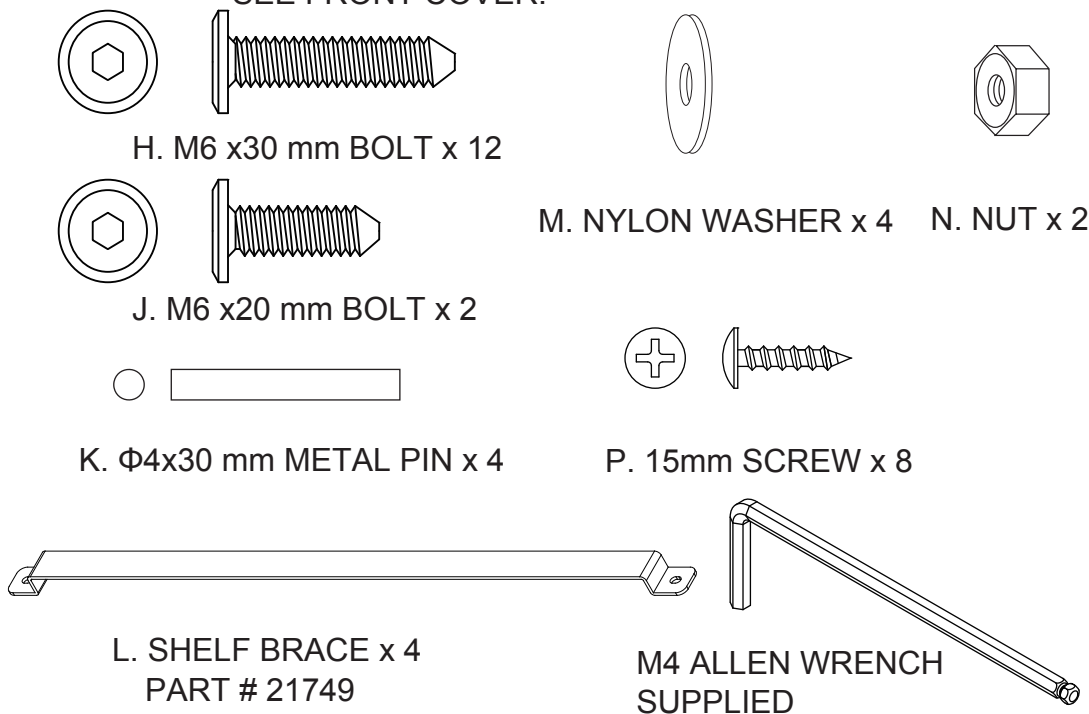

No drills necessary. Do not use power screwdriver.

Phillips Screwdriver
Pliers or Adjustable Wrench Required for Assembly (not supplied)

SECTION 1: CHANGING TABLE ASSEMBLY

STEP 1

PARTS AND TOOLS REQUIRED TO COMPLETE STEP

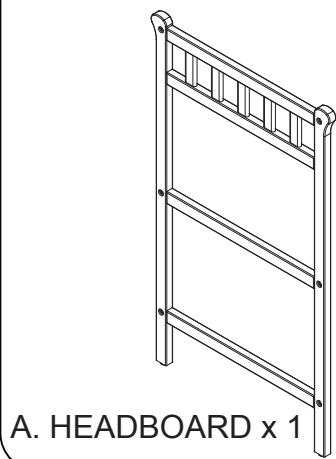

B. TOP RAIL x 2

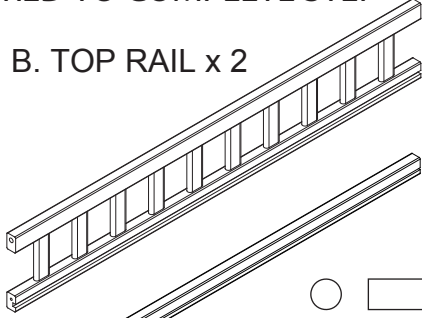

C. LOWER RAIL x 4

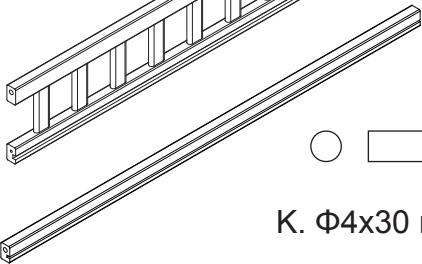

K. $\Phi 4 \times 30$ mm METAL PIN x 2

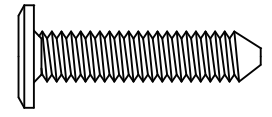
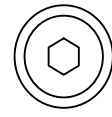
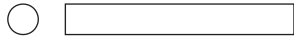

H. M6 x30 mm BOLT x 6

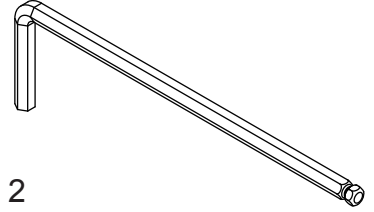

M4 ALLEN WRENCH
SUPPLIED

ATTACH (2) TOP RAILS (PART B) AND (4) LOWER RAILS (PART C) TO THE HEADBOARD (PART A) WITH (2) $\Phi 4 \times 30$ mm METAL PINS (PART K) AND (6) M6x30mm BOLTS (PART H) USING THE M4 ALLEN WRENCH AS SHOWN. **BE SURE THE GROOVES FACE TO THE INSIDE.**

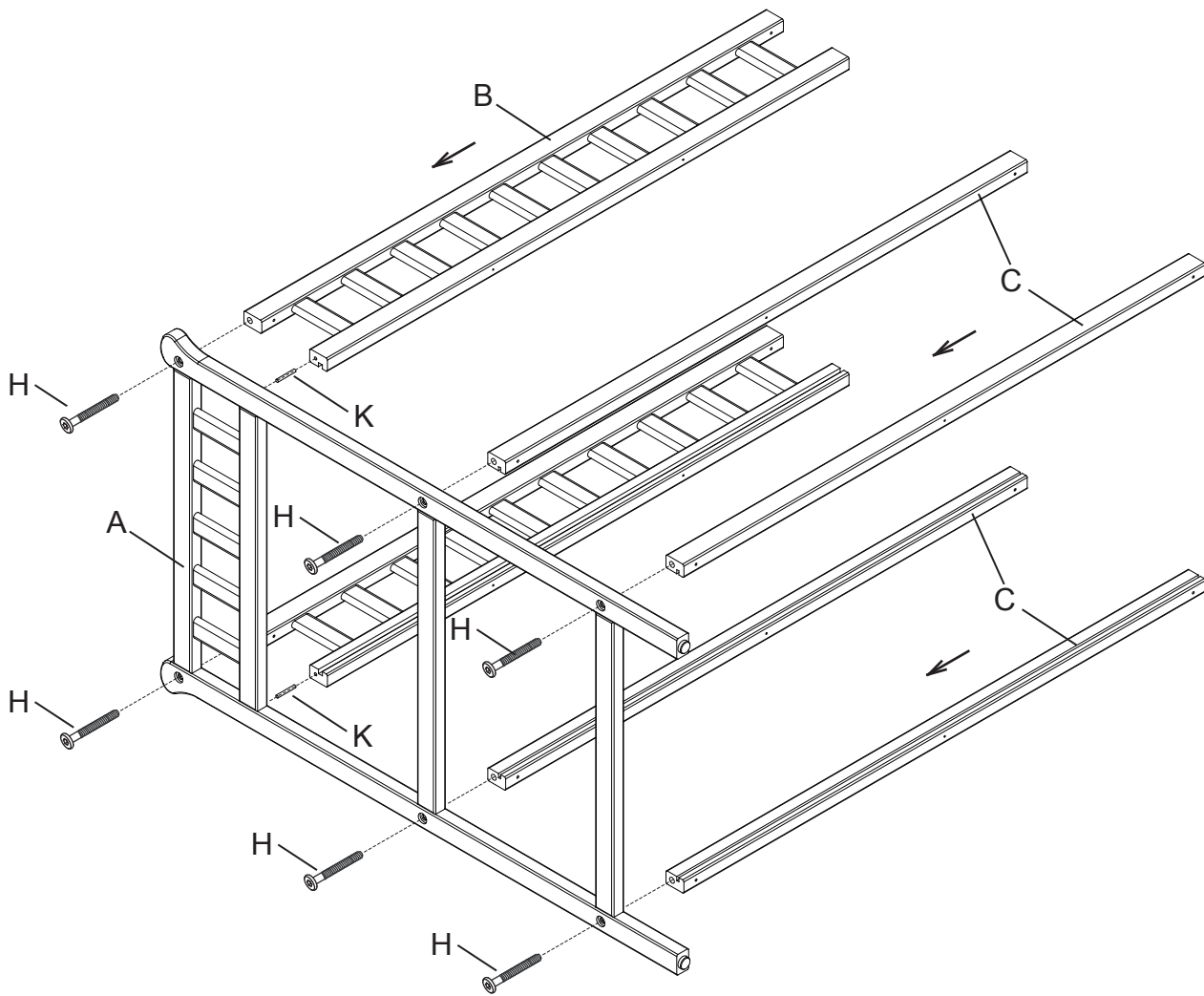

SECTION 1: CHANGING TABLE ASSEMBLY

STEP 2

PARTS AND TOOLS REQUIRED TO COMPLETE STEP

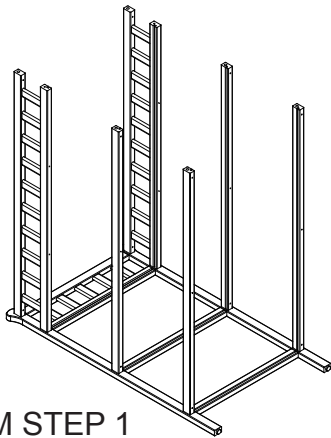

FROM STEP 1

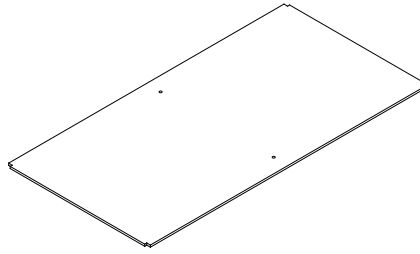

D. TOP SHELF x 1

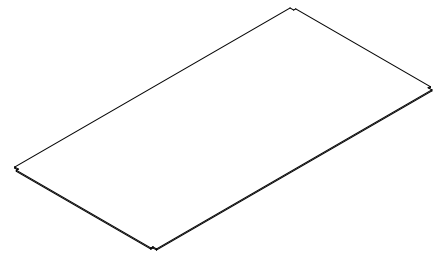

E. LOWER SHELF x 2

LAY THE HEADBOARD ON THE FLOOR, RAILS UP. SLIDE THE TOP SHELF (PART D) IN THE GROOVES ON THE TOP RAILS, INTO THE GROOVE ON THE HEADBOARD, SLIDE (2) LOWER SHELVES (PART E) IN THE GROOVES ON THE LOWER RAILS, INTO THE GROOVES ON THE HEADBOARD AS SHOWN.

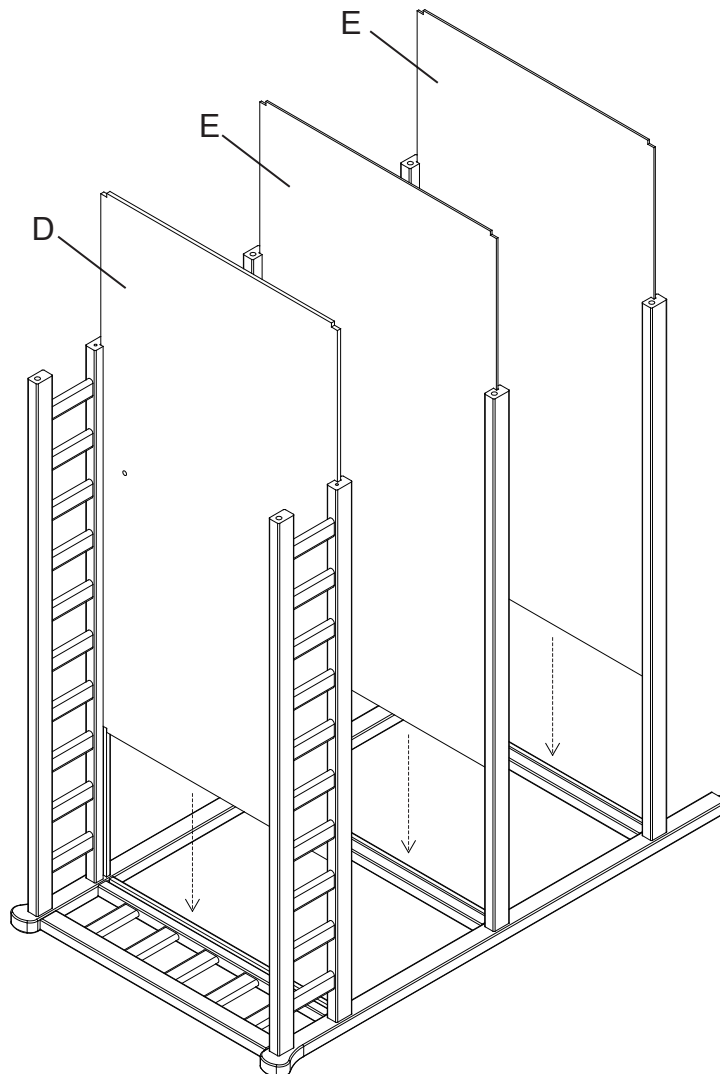

SECTION 1: CHANGING TABLE ASSEMBLY

STEP 3

PARTS AND TOOLS REQUIRED TO COMPLETE STEP

FROM STEP 2

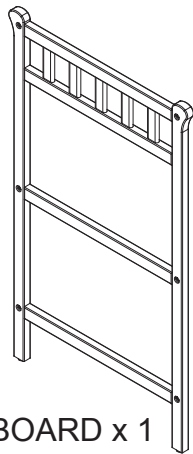
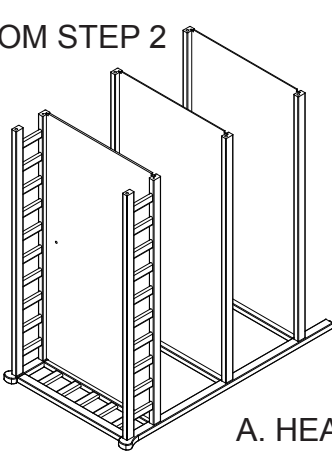

A. HEADBOARD x 1

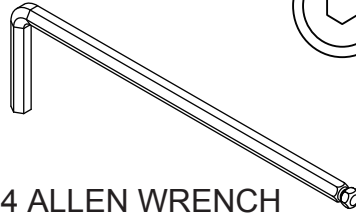

M4 ALLEN WRENCH
SUPPLIED

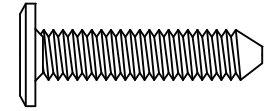
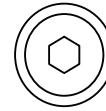

H. M6 x30 mm BOLT x 6



K. Φ 4x30 mm METAL PIN x 2

ATTACH (1) HEADBOARD (PART A) TO THE ASSEMBLY FROM STEP 2 WITH (2) Φ 4x30 mm METAL PINS (PART K) AND (6) M6x30 mm BOLTS (PART H) USING THE M4 ALLEN WRENCH AS SHOWN.

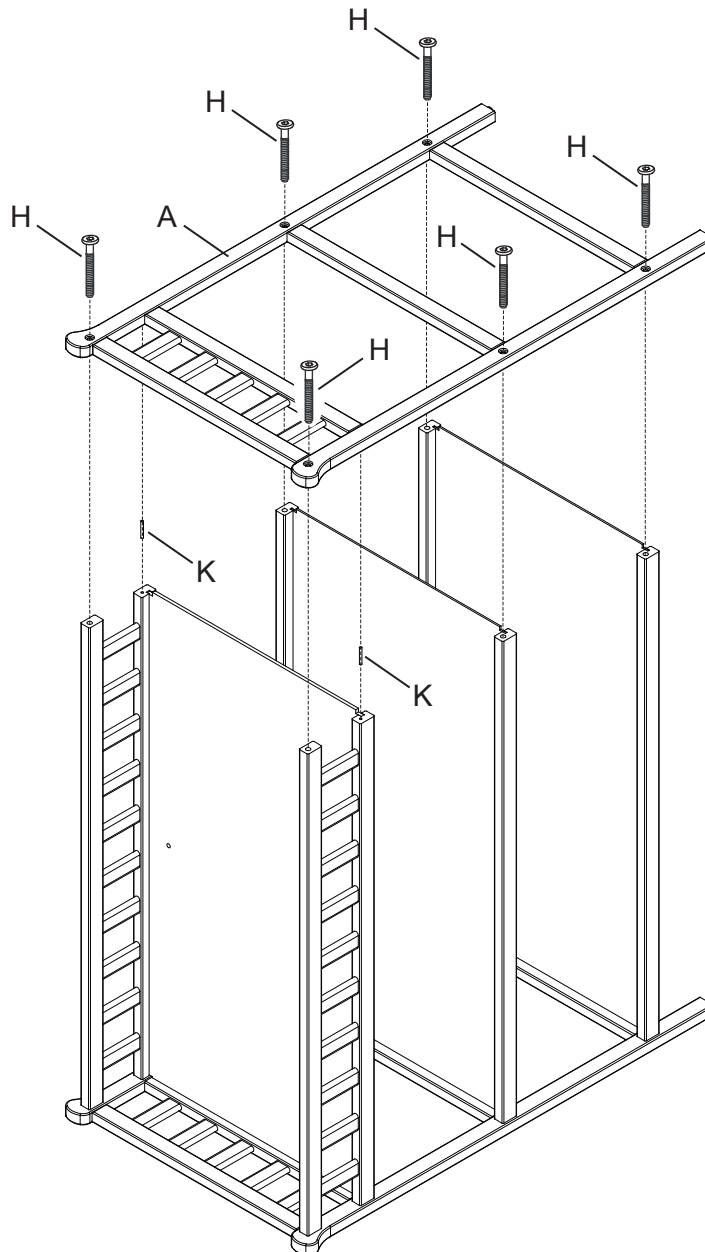

SECTION 1: CHANGING TABLE ASSEMBLY

STEP 4

PARTS AND TOOLS REQUIRED TO COMPLETE STEP

FROM STEP 3

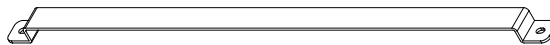
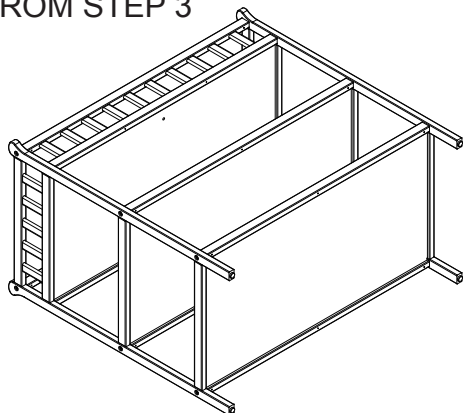

L. SHELF BRACE x 4



P. 15mm SCREW x 8

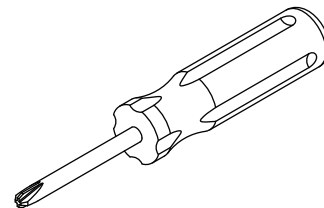

PHILLIPS SCREWDRIVER
(NOT SUPPLIED)

ATTACH (4) SHELF BRACES (PART L) TO THE RAILS USING (8) 15mm SCREWS (PART P). TIGHTEN WITH THE PHILLIPS SCREWDRIVER.

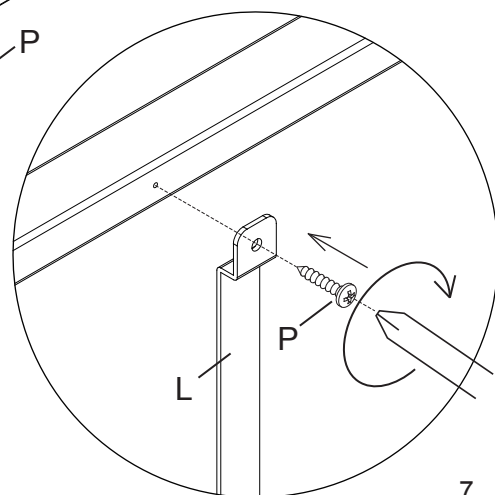
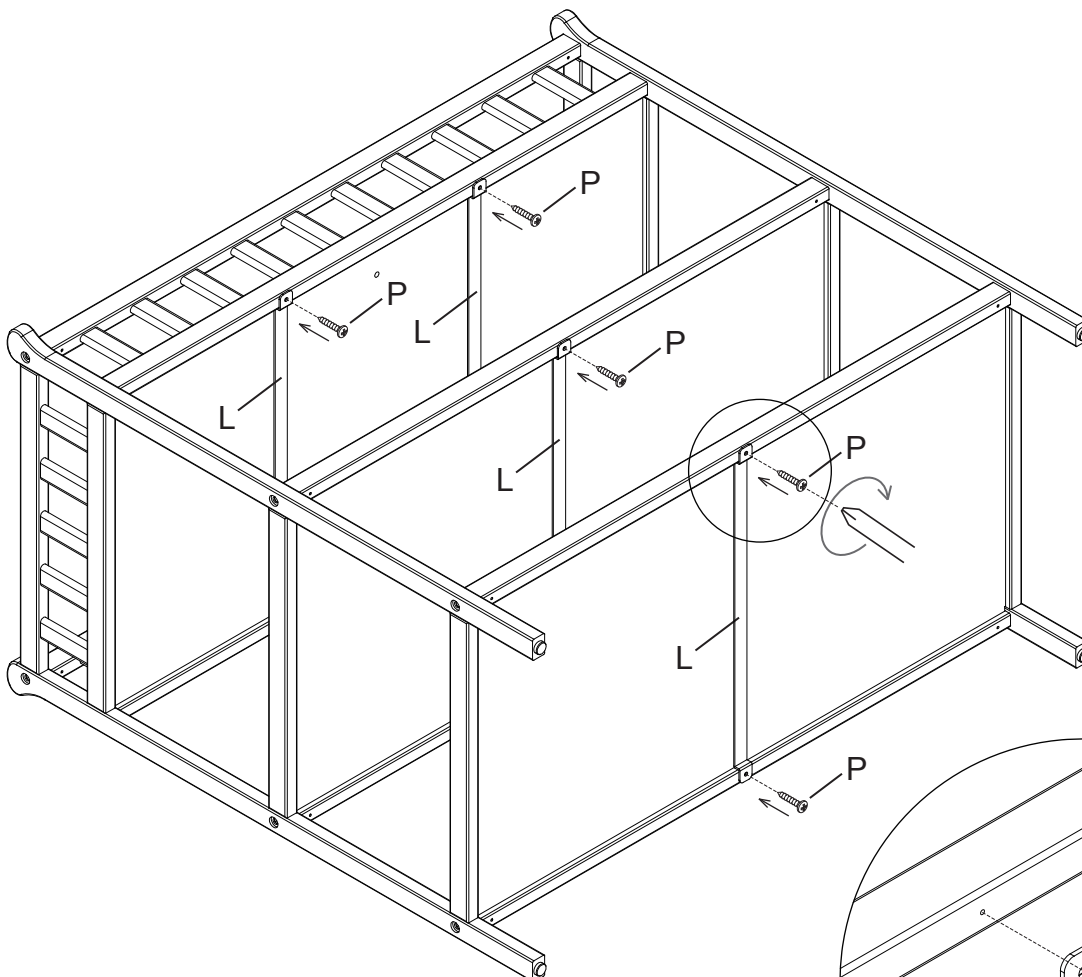

SECTION 1: CHANGING TABLE ASSEMBLY

STEP 5

PARTS AND TOOLS REQUIRED TO COMPLETE STEP

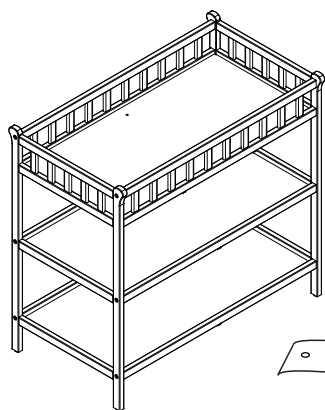

FROM STEP 4



M. NYLON WASHER x 4

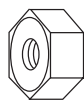

N. NUT x 2

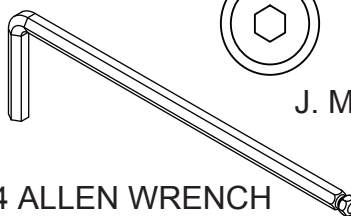

M4 ALLEN WRENCH
SUPPLIED

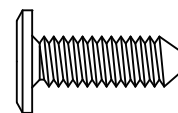

J. M6 x20 mm BOLT x 2



F. RESTRAINT HARNESS x 1

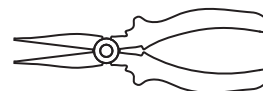

PLIERS OR ADJUSTABLE
WRENCH (NOT SUPPLIED)

ALIGN THE HOLE IN THE END OF THE STRAP OF THE RESTRAINT HARNESS (PART F) WITH THE HOLE IN THE TOP SHELF. INSERT (1) M6x20 mm BOLTS (PART J) THROUGH A NYLON WASHER (PART M), THE RESTRAINT STRAP AND THE HOLE IN THE SHELF. ADD (1) NYLON WASHER (PART M) WITH A NUT (PART N). HOLD THE NUT WITH A PLIERS OR ADJUSTABLE WRENCH. REPEAT WITH THE OTHER SIDE OF THE STRAP AS SHOWN.

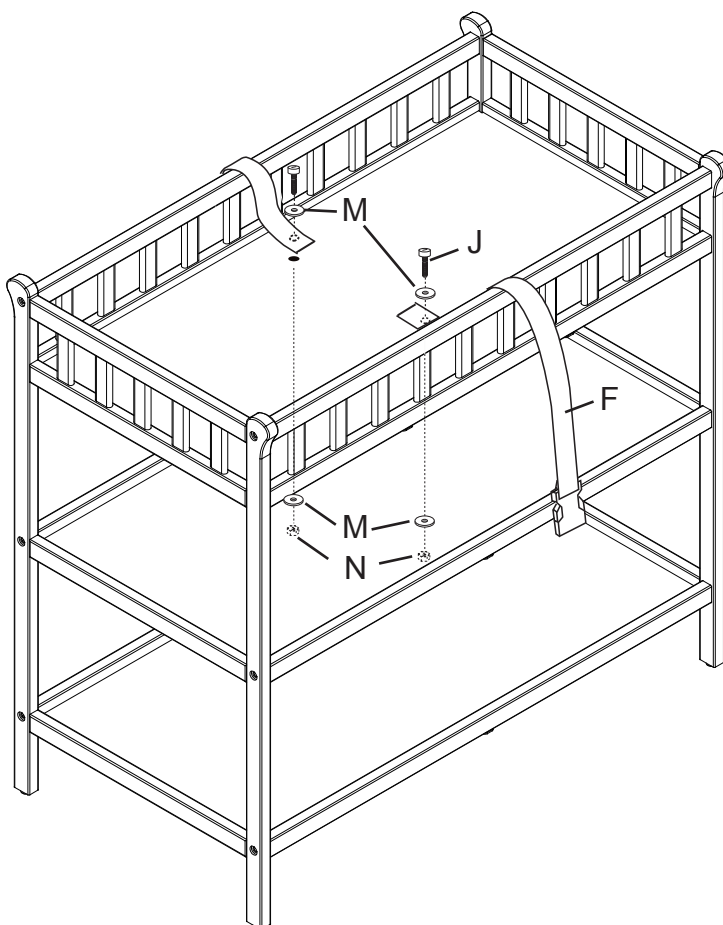

SECTION 1: CHANGING TABLE ASSEMBLY

STEP 6

PARTS AND TOOLS REQUIRED TO COMPLETE STEP

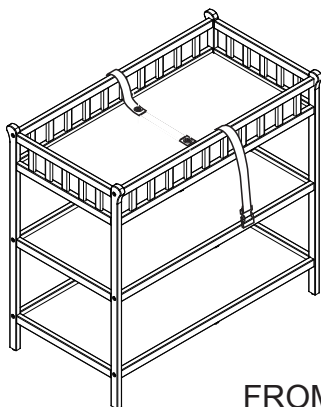

FROM STEP 5

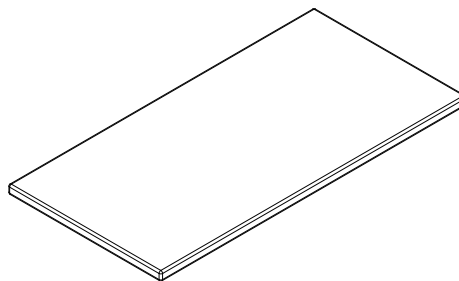

G. FOAM PAD x 1

PLACE THE FOAM PAD (PART G) ONTO THE TOP SHELF (PART D) ON TOP OF THE ATTACHED STRAP FROM STEP 5, BE SURE THE BUCKLE ON THE STRAP IS OVER THE PAD AS SHOWN.

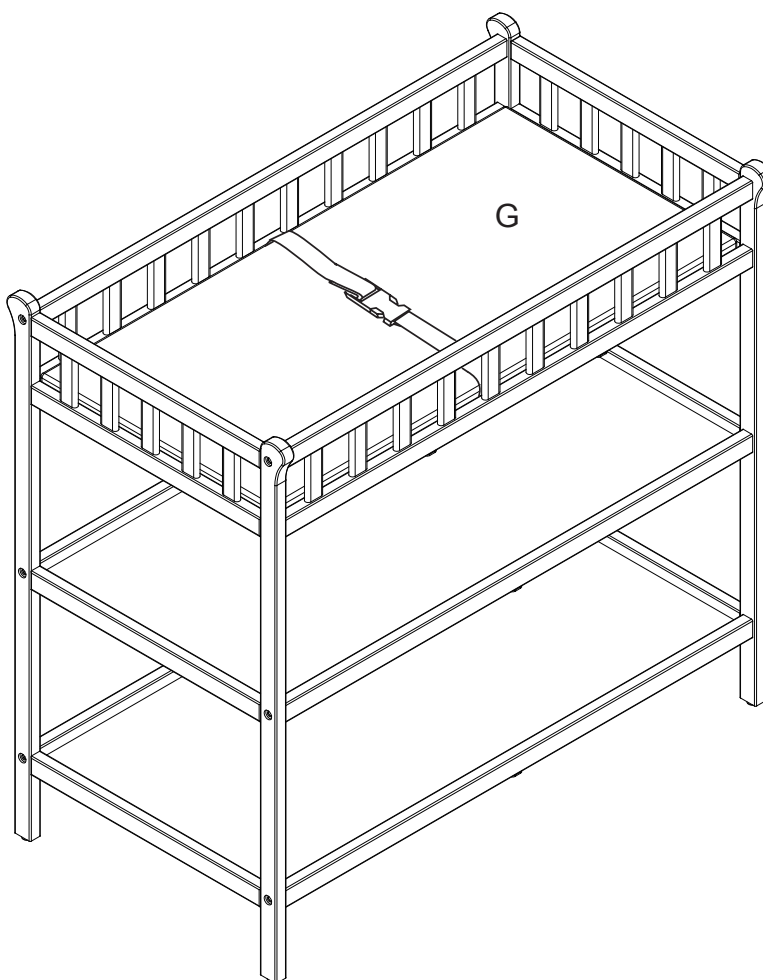

SECTION 1: CHANGING TABLE ASSEMBLY

FINAL

RESTRAINT HARNESS SYSTEM USE:

- . PLACE THE INFANT ON THE CHANGING TABLE FOAM PAD.
- . POSITION THE RESTRAINT HARNESS OVER THE MIDDLE OF THE INFANT'S TORSO AND INSERT THE BUCKLED ENDS INTO EACH OTHER UNTIL THE LOCK SHUT WITH A CLICK.
- . GENTLY PULL THE LOOSE END OF THE STRAP TO LIGHTLY SNUG THE RESTRAINT HARNESS AROUND THE INFANT.

MAINTENANCE

- . CHECK FASTENERS PERIODICALLY FOR TIGHTNESS. DO NOT OVER TIGHTEN. THIS MAY CAUSE DISTORTION OR BREAKAGE.

⚠ WARNING : FALL HAZARD
ALWAYS KEEP CHILD WITHIN ARMS REACH.

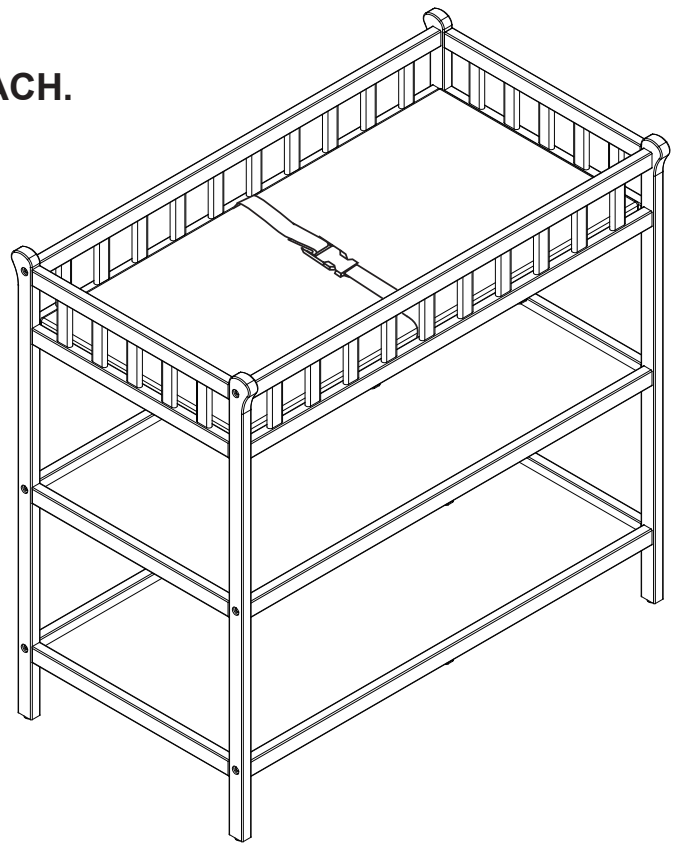
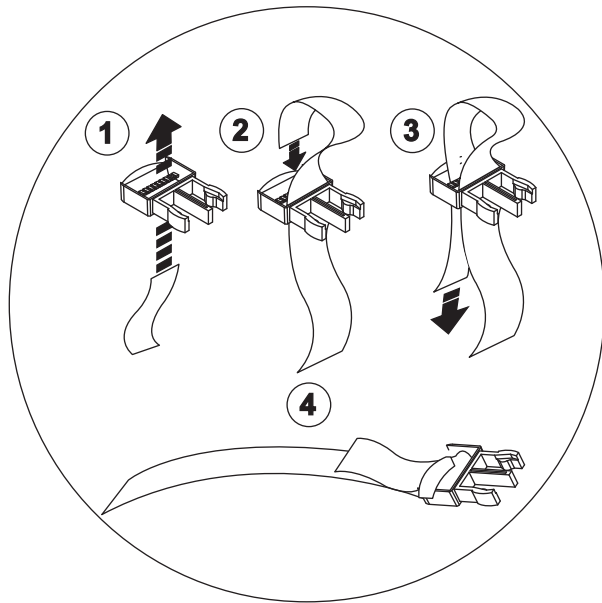

TO FASTEN STRAP - PUSH BUCKLE SIDE TOGETHER
BE SURE BUCKLE IS FULLY FASTENED TO
SECURE CHILD SAFELY

TO RELEASE PRESS BOTH TABS AND PULL APART

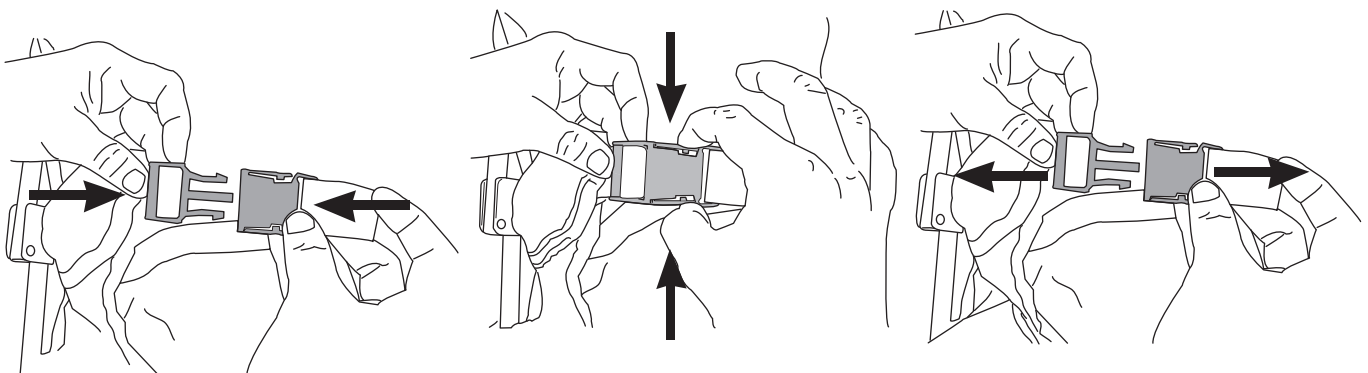



Consumer Care:
www.DeltaChildren.com

Delta Children's Products
114 West 26th Street
New York, NY 10001
Tele.212-645-9033

Warranty: This Delta product is warranted to be free from defects for a period of 90 days from the date of purchase under normal use. This warranty extends only to the original retail purchaser and is valid only when supplied with proof of purchase, or if received as a gift, when the registration is on file with Delta.

To register your product for important safety alerts and updates to your product please visit www.DeltaChildren.com

Please do not return this item to the store before contacting us about missing parts or with any questions.

To report a problem, please log on to www.DeltaChildren.com and click the Consumer Care Tab, or contact us by phone at (212) 645-9033.

In the event that you need to contact our customer service department please have the Style Number and Lot Number available. Use the space below to make note of those numbers. They can be found on the label on the Top Shelf.

STYLE No: 7515

COLOR

REV

FTY

Lot No. : _____

Pack Date: _____

Date of Purchase: _____ (you should also keep your receipt)