

# Delta™

Children's Products

READ ALL INSTRUCTIONS BEFORE  
ASSEMBLY AND USE.

**KEEP INSTRUCTIONS FOR FUTURE USE.**

**⚠ ADULT ASSEMBLY REQUIRED**

DUE TO THE PRESENCE OF SMALL PARTS  
DURING ASSEMBLY, KEEP OUT OF REACH OF  
CHILDREN UNTIL ASSEMBLY IS COMPLETE.

## STEP STOOL

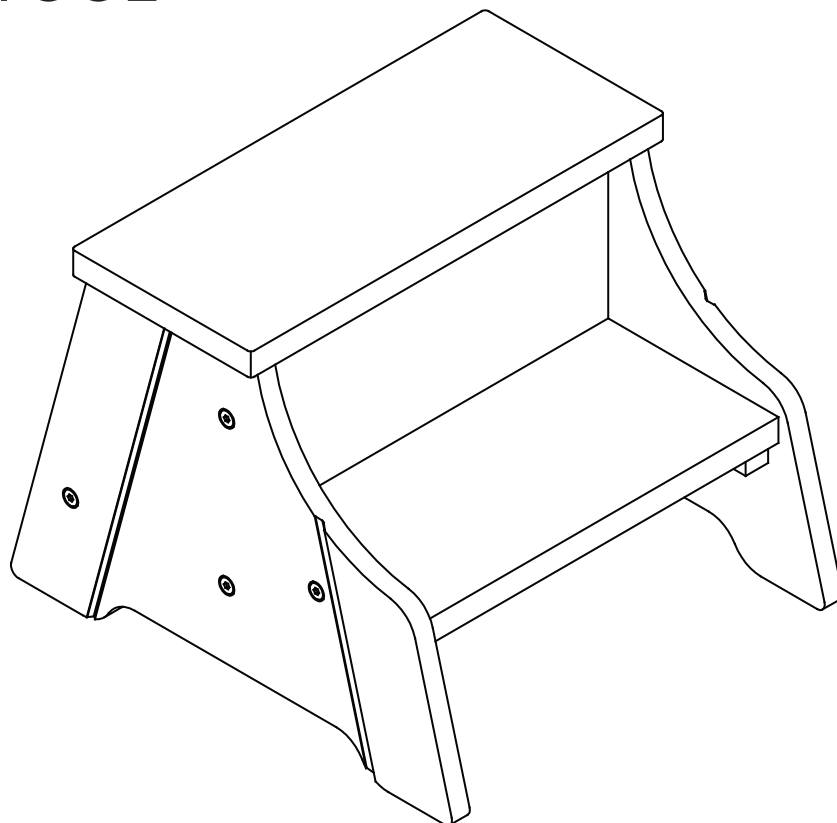

**THIS PRODUCT IS NOT INTENDED FOR INSTITUTIONAL OR COMMERCIAL USE.**

**STYLE No: 1500 -**



**COLOR**



**REV**



**FACTORY**

When contacting Delta Consumer Care you  
will need to reference the above number.

**Consumer Care:**

**[www.deltachildrensproducts.com](http://www.deltachildrensproducts.com)**

Delta Children's Products

114 West 26th Street

New York, NY 10001

Tele.212-645-9033

To register your product for important safety alerts and updates to your product  
please visit **[www.deltachildrensproducts.com](http://www.deltachildrensproducts.com)** and click on Product Registration.

## NOTES ON ASSEMBLY:

-During the assembly process whenever using screws or bolts, check each by placing the screw/bolt on the diagram of the item which is drawn actual size and design. Be sure to use the proper size and shape specified in the instructions.

-To assemble this unit you may be required to place the unit on it's side and face. It is strongly recommended that assembly is done on a soft, non-abrasive surface to avoid damaging the finish.

## NOTES ON CARE AND MAINTENANCE:

- **Do not** scratch or chip the finish.

- Inspect the product periodically, contact delta children's products for replacement parts or questions.

- **Do not** store the product or any parts in extreme temperatures and conditions such as a hot attic or a damp, cold basement. These extremes can cause a loss of structural integrity.

-To preserve the luster of the high quality finish on your product, it is recommended to place a doily or felt pad under any items you place on the finish.

-Clean with a damp cloth, then a dry cloth to preserve the original luster and beauty of this fine finish.

-**Do not** use abrasive chemicals.

-**Do not** spray cleaners directly onto furniture.

-Lift slightly when moving on carpeting to prevent leg breakage.

-Use of a vaporizer near furniture will cause wood to swell and finish to peel.

## PARTS

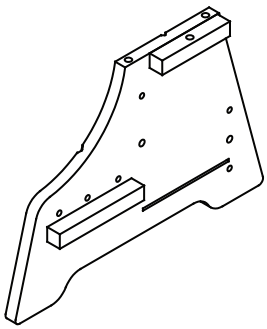

A. Left Side x1  
Part #21846

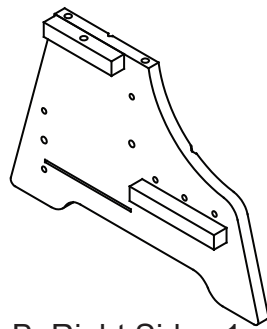

B. Right Side x1  
Part #21847

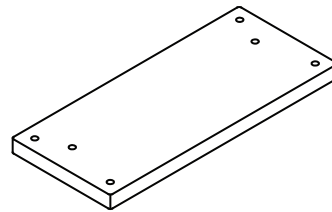

C. Top Step x1  
Part #21848

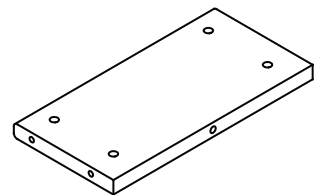

D. Step x1  
Part #21849

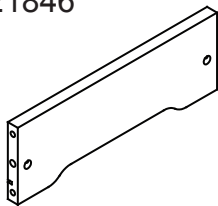

E. Back Rail x1  
Part #21850

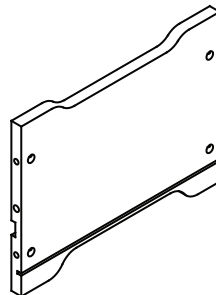

F. Center Partition x1  
Part #21851

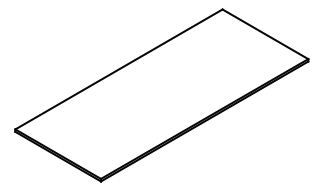

G. Storage Shelf x1  
Part #21852

HARDWARE KIT PART: #21856 FOR COLOR 100, #21855 FOR COLOR 260,  
#21853 FOR COLOR 604. SEE FRONT COVER.



H. 50mm Bolt x8

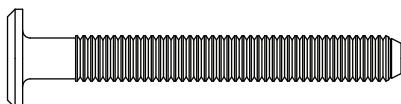

K. 25mm Bolt x2

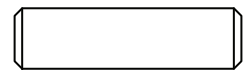
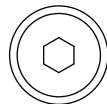

M. 30mm Wood  
Dowel x14



N. Barrel  
Nut x8

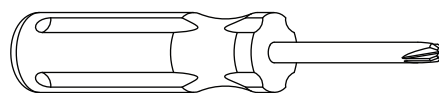

PHILLIPS SCREWDRIVER  
NOT SUPPLIED

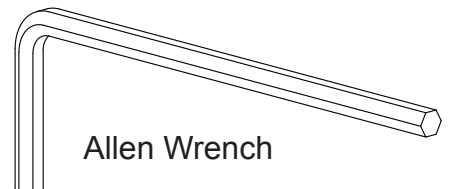

Allen Wrench

# STEP 1:

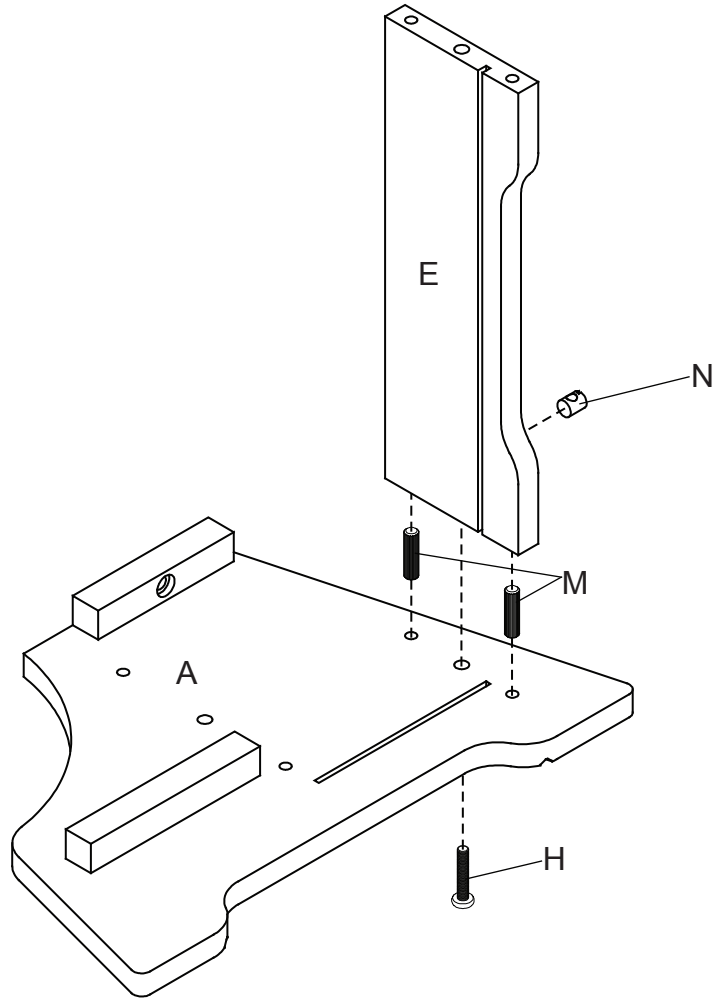

# STEP 2:

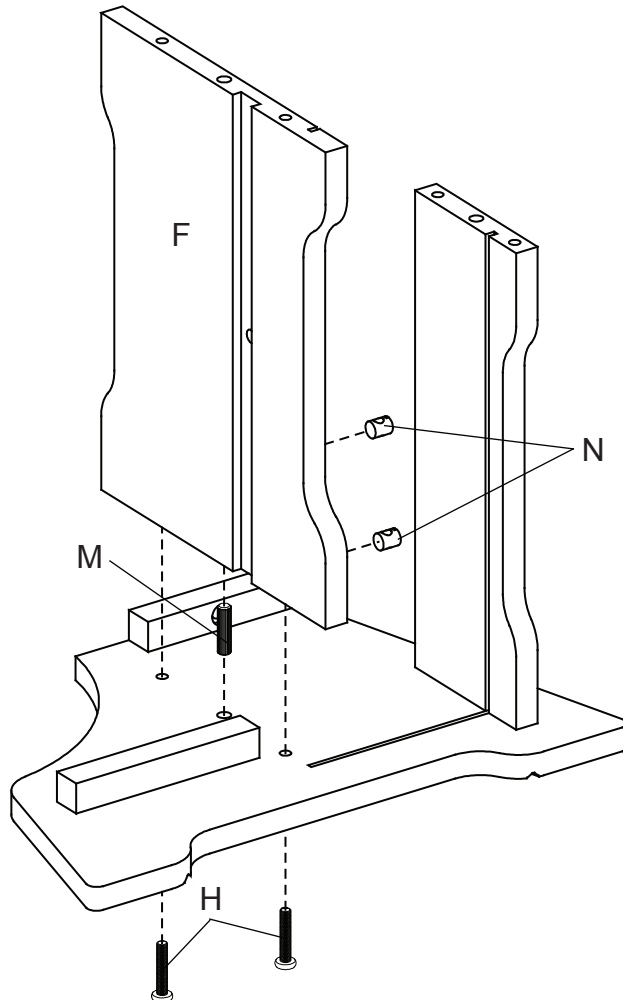

### STEP 3:

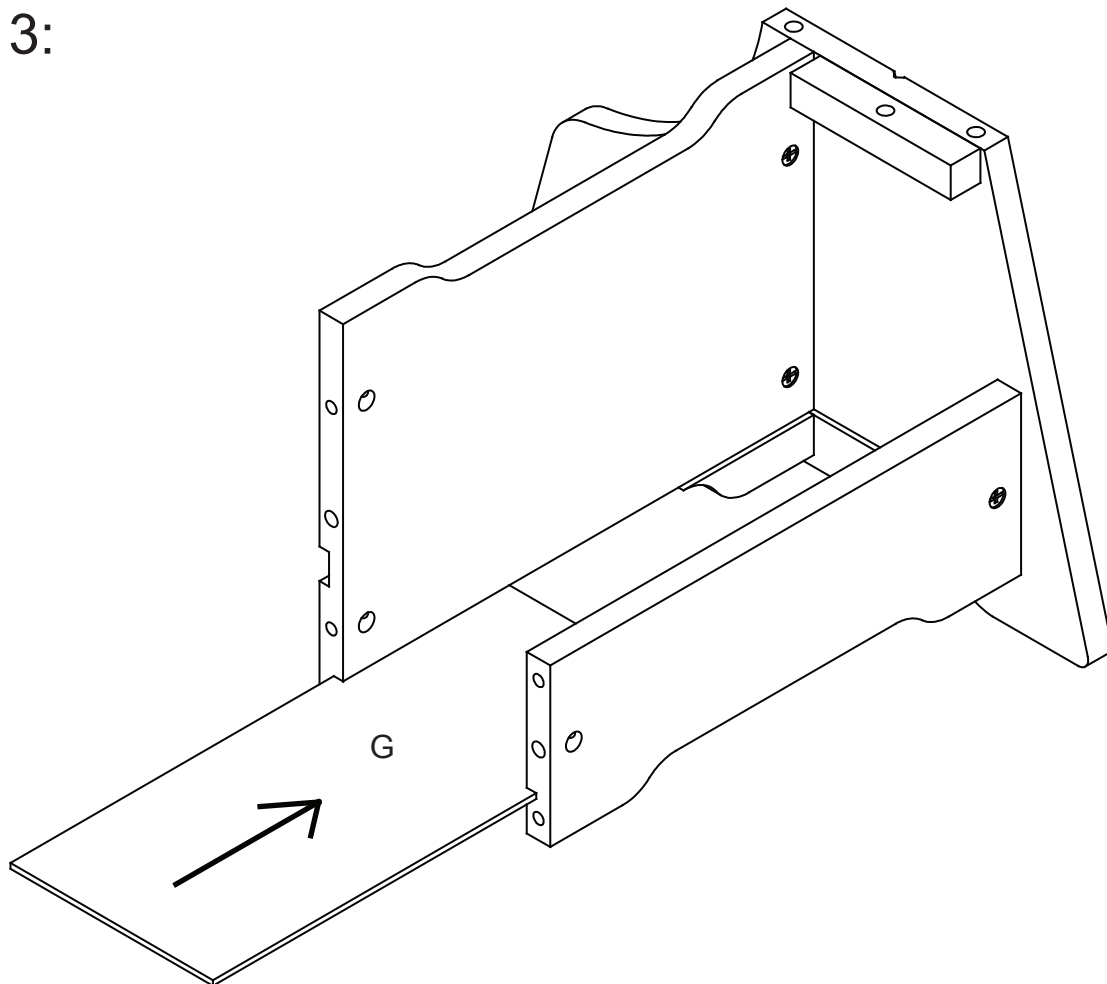

### STEP 4:

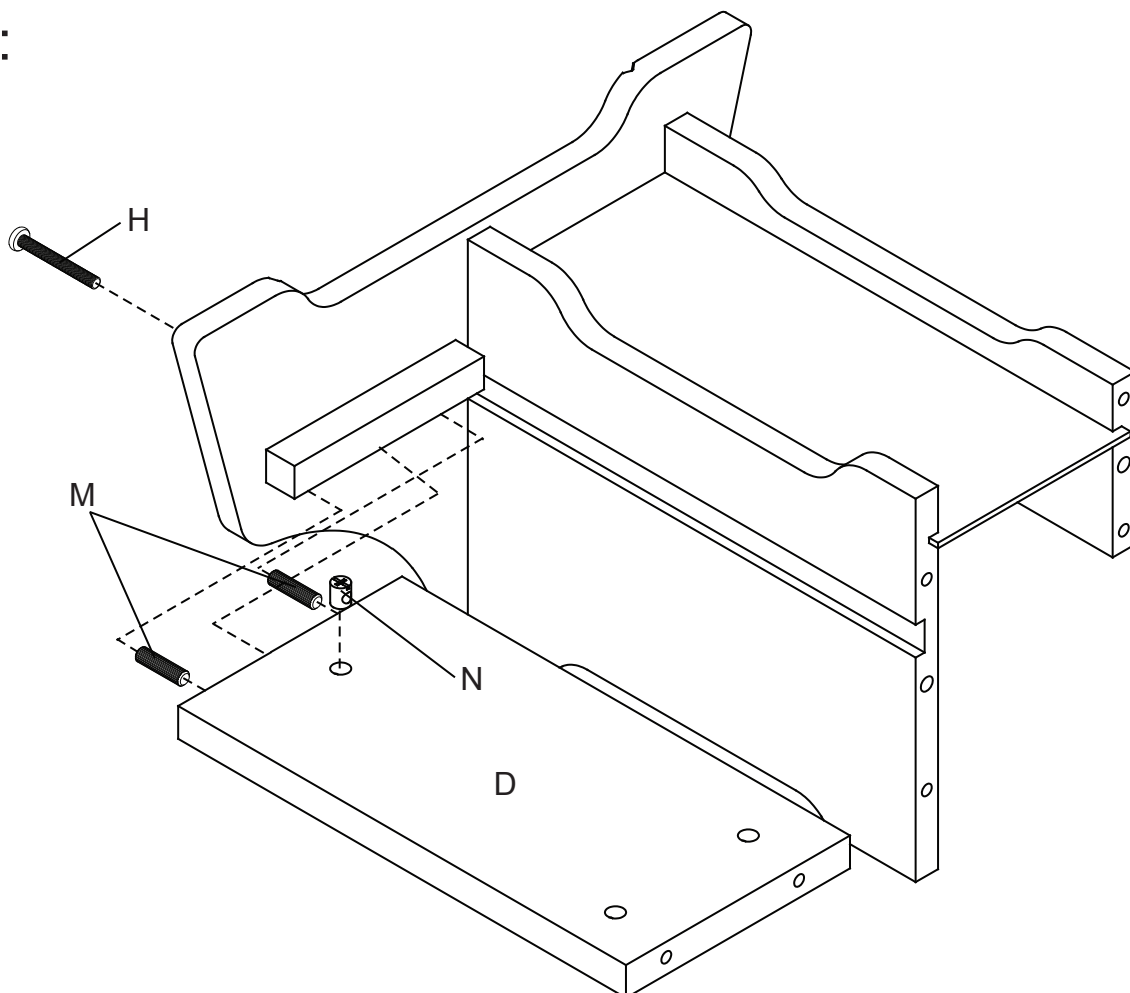

# STEP 5:

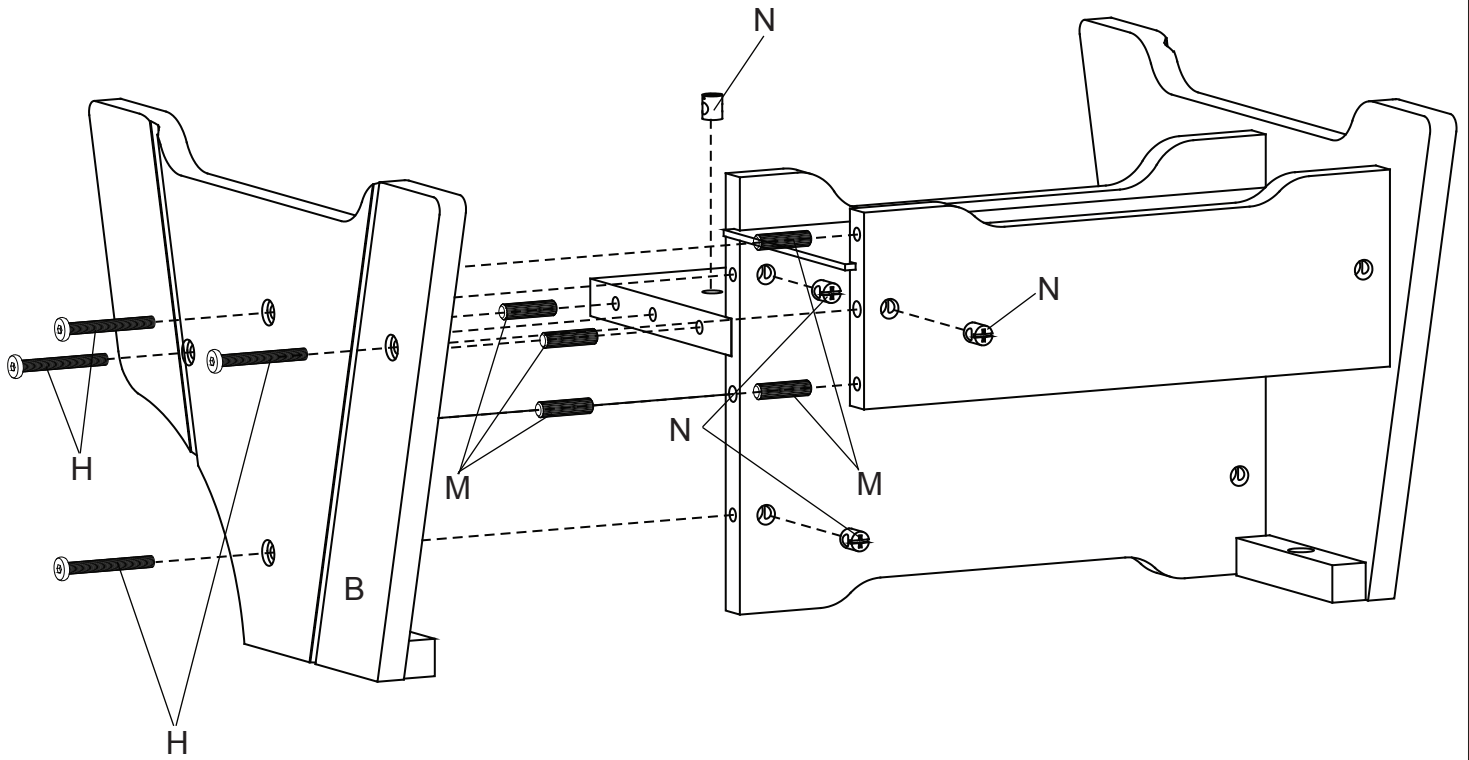

# STEP 6:

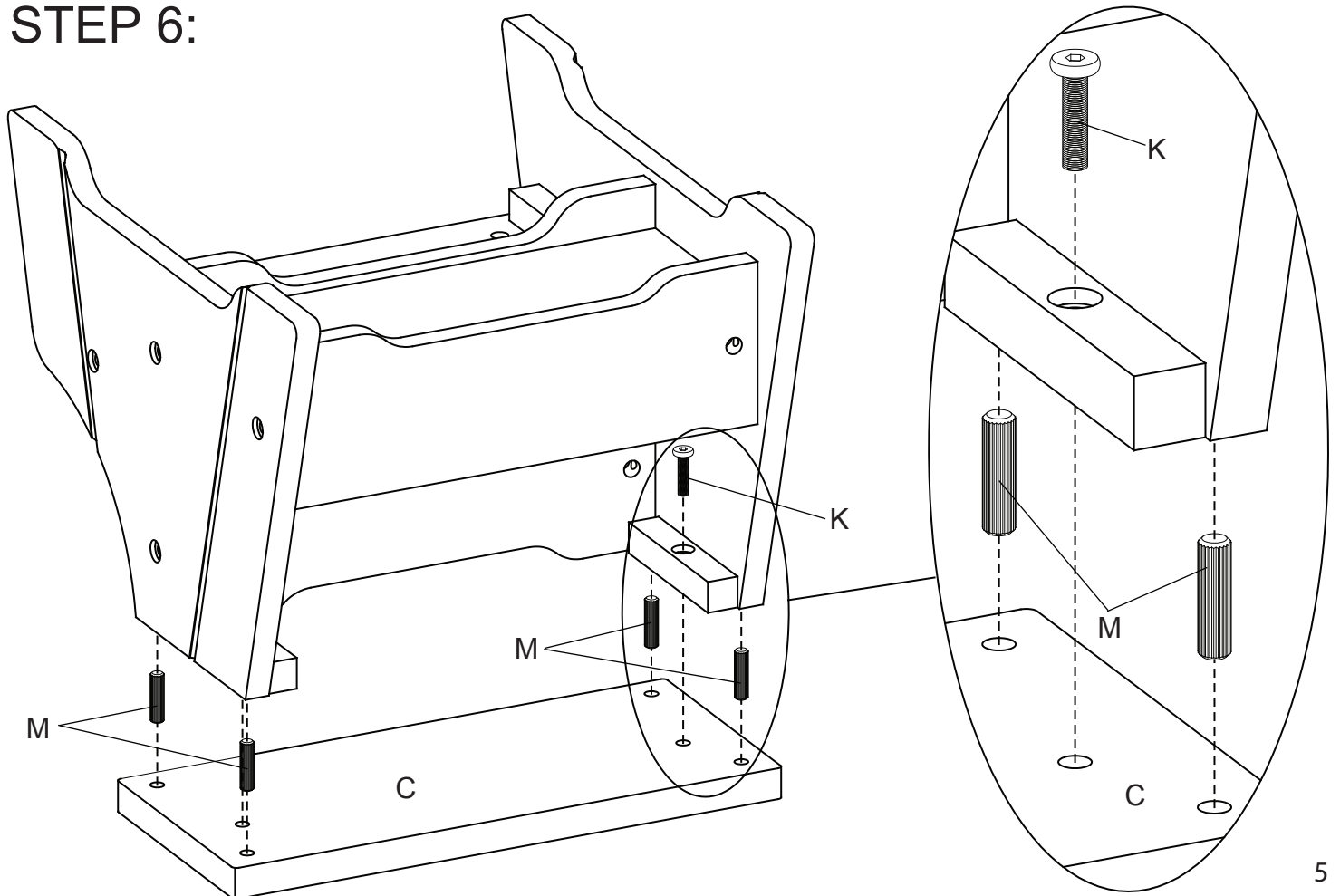



**Children's Products**

Consumer Care:

[www.deltachildrensproducts.com](http://www.deltachildrensproducts.com)

Delta Children's Products

114 West 26th Street

New York, NY 10001

Tele.212-645-9033

**Warranty:** This Delta Product is warranted to be free from defects for a period of 90 days from the date of purchase under normal use. This warranty extends only to the original retail purchaser and is valid only when supplied with proof of purchase, or if received as a gift, when the registration is on file with Delta.

Please visit [www.deltachildrensproducts.com](http://www.deltachildrensproducts.com) and click on Product Registration to register your product for important safety alerts and updates.

For questions or comments, please log on to [www.deltachildrensproducts.com](http://www.deltachildrensproducts.com) and click Consumer Care, or contact us by phone at (212) 645-9033.

In the event that you need to contact our Consumer Care department please have the Style Number and Lot Number available. If they are not printed below they can be found on the label on the Step bottom.

Use the space below to make note of those numbers.

STYLE No: 1500 -   
COLOR

REV FACTORY

Lot No. : \_\_\_\_\_

Pack Date: \_\_\_\_\_

Date of Purchase: \_\_\_\_\_ (you should also keep your receipt)