

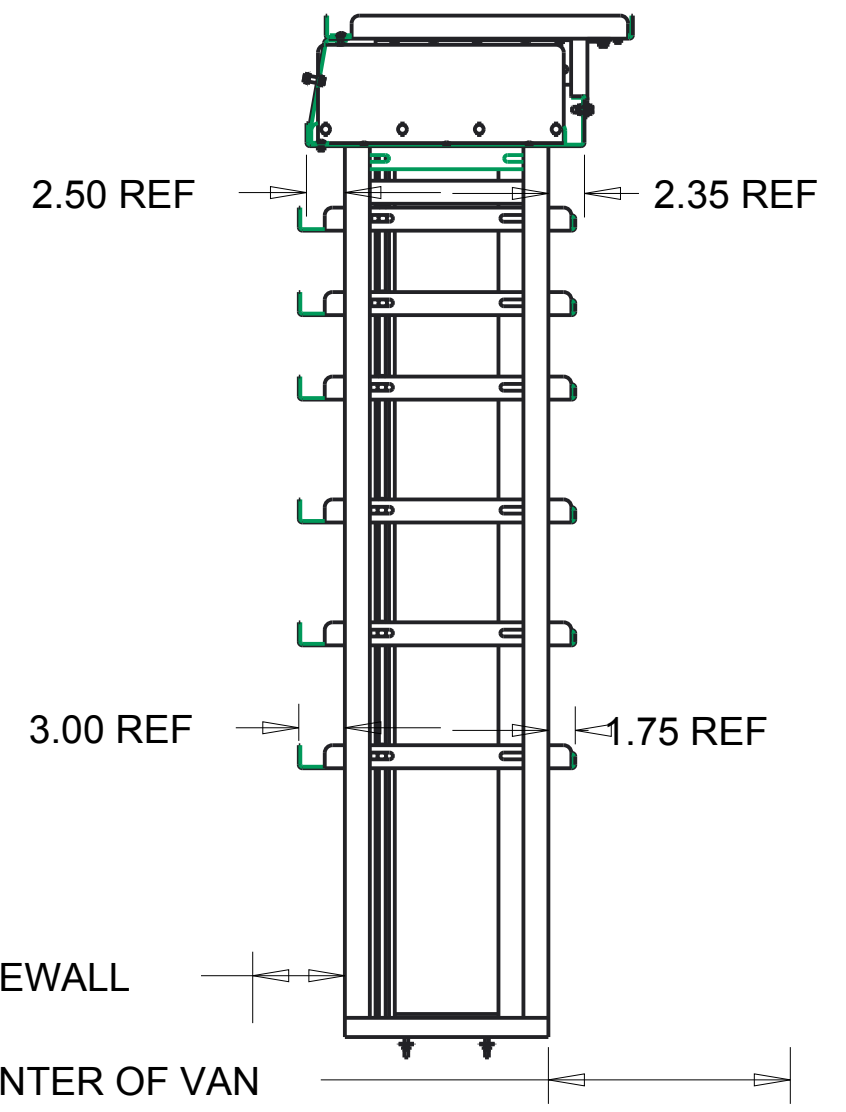

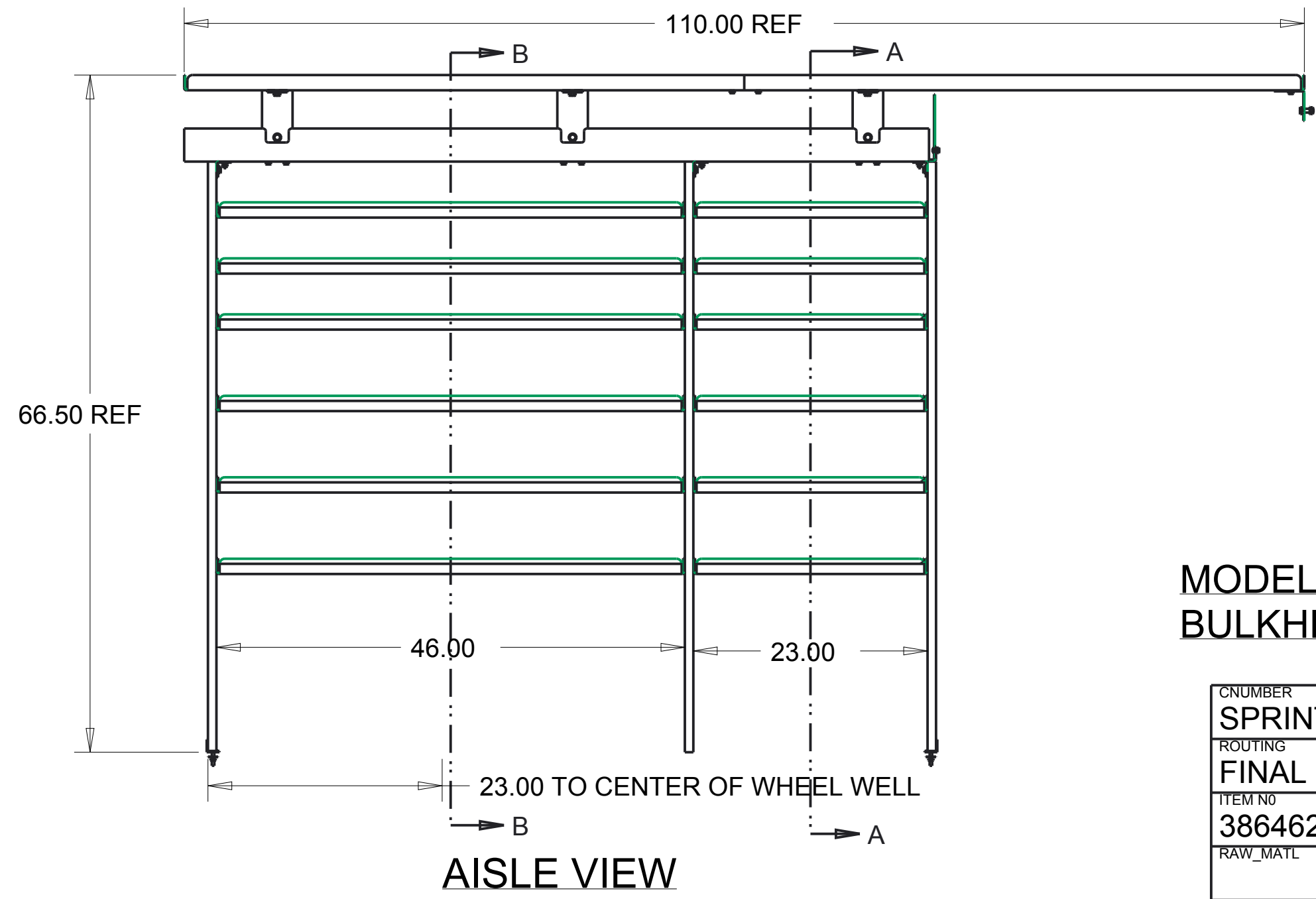

BBL NO.	ITEM DESCRIPTION	WEIGHT	MATL CODE	QTY REQD	ITEM NO.	MODEL NAME
1	ANGLE - .10X3.00X3.00X13.25	0.334	BB2	1	386453	P16C0440
2	ANGLE-.10X1.50X1.50X 13.25	0.334	BB2	3	385287	P15C0410
3	CHANNEL-LADDER SUPPORT	0.317	BB1	3	386448	P16C0395
4	NUT-HEX .25 SST	0.007	E1	40	807862	807862
5	NUT-HEX .38 LK	0.018	E1	11	1485	1485
6	NUT-UNISTRUT W/O SPRING .38-16	0.086	C4	54	802807	802807
7	PIPE STOP SHEET	1.127	BB2	1	386422	P16C0285
8	SCREW-CARRIAGE .25X .50	0.013	E0	27	826255	826255
9	SCREW-CARRIAGE .25X .75	0.018	E0	9	1430	1430
10	SCREW-HEX 3/8-13X 1.00 FLANGE	0.059	E1	11	1490	1490
11	SCREW-HEX.25X1.50 SST	0.027	E0	4	803172	803172
12	SCREW-HEX.38X .75 GR5	0.043	E0	54	802804	802804
13	SHEET-.12X 4.00X 19.50	9.610	BB1	1	386447	P16C0394
14	SHELF-LADDER LH 55"	17.981	BB2	1	386459	P16C0459
15	SHELF-LADDER RH	17.104	BB2	1	386460	P16C0458
16	SHELF-TOP 18"x73.833"	10.815	BB2	1	386442	P16C0456
17	SHELF-TRAY 18"x23"	4.981	BB2	6	386376	SHELF_1_DS
18	SHELF-TRAY 18"x46"	9.633	BB2	6	385297	SHELF_2_DS
19	SUPPORT ASM-LADDER	0.447	ZA	3	385200	385200
20	UNISTRUT ASM-DOUBLE	9.602	ZA	1	386420	386445
21	UNISTRUT ASM-SINGLE	6.302	ZA	2	386419	386446
22	WASHER-FENDER .25 SST	0.009	E2	8	820746	820746
23	WASHER-FLAT .38 D-SHAPED	0.007	E2	54	816154	816154
24	WASHER-LOCK .25 SST	0.002	E2	40	803630	803630

NOTE:
FOR OPTIONAL SHELF LINER KIT,
USE #386467



MODEL DESIGNED FOR USE WITH OEM BULKHEAD. AFTERMARKET BULKHEADS MAY REQUIRE ADITIONAL MODIFICAITON.

NUMBER	WEIGHT	TOLERANCE UNLESS OTHERWISE SPECIFIED	 A company of VT Systems
SPRINTER	134.923		
ROUTING	MATL CODE	.XX=+/- .060 .XXX=+/- .030	
FINAL	ZA		
ITEM NO	SHAPE DESC		252-946-6521 vtackney.com hackney.com kidron.com vtvisioncomms.com
386462			
RAW_MATL	HRS		
	0.000		
DRAWN BY	DATE	DESCRIPTION	SHELF ASM.- DRIVERSIDE SPRINTER 144"WB HIGH ROOF 23-46
ALB	30-Aug-16		
APPROVED BY	DATE		
SUPERSEDES	SUPERSEDED BY	SCALE	DWG NAME
		0.032	P16C0454 Sheet 1 of 4

THIS PRINT AND ALL RIGHTS TO THE DESIGN AND DETAIL THEREON ARE THE PROPERTY OF VT HACKNEY AND IS LOANED TO THE RECIPIENT SUBJECT TO RETURN UPON DEMAND. ITS CONTENTS ARE CONFIDENTIAL AND MUST NOT BE COPIED OR SUBMITTED TO OUTSIDE PARTIES FOR USE OR EXAMINATION. COPYRIGHT 2016 VT HACKNEY A COMPANY OF VT SYSTEMS

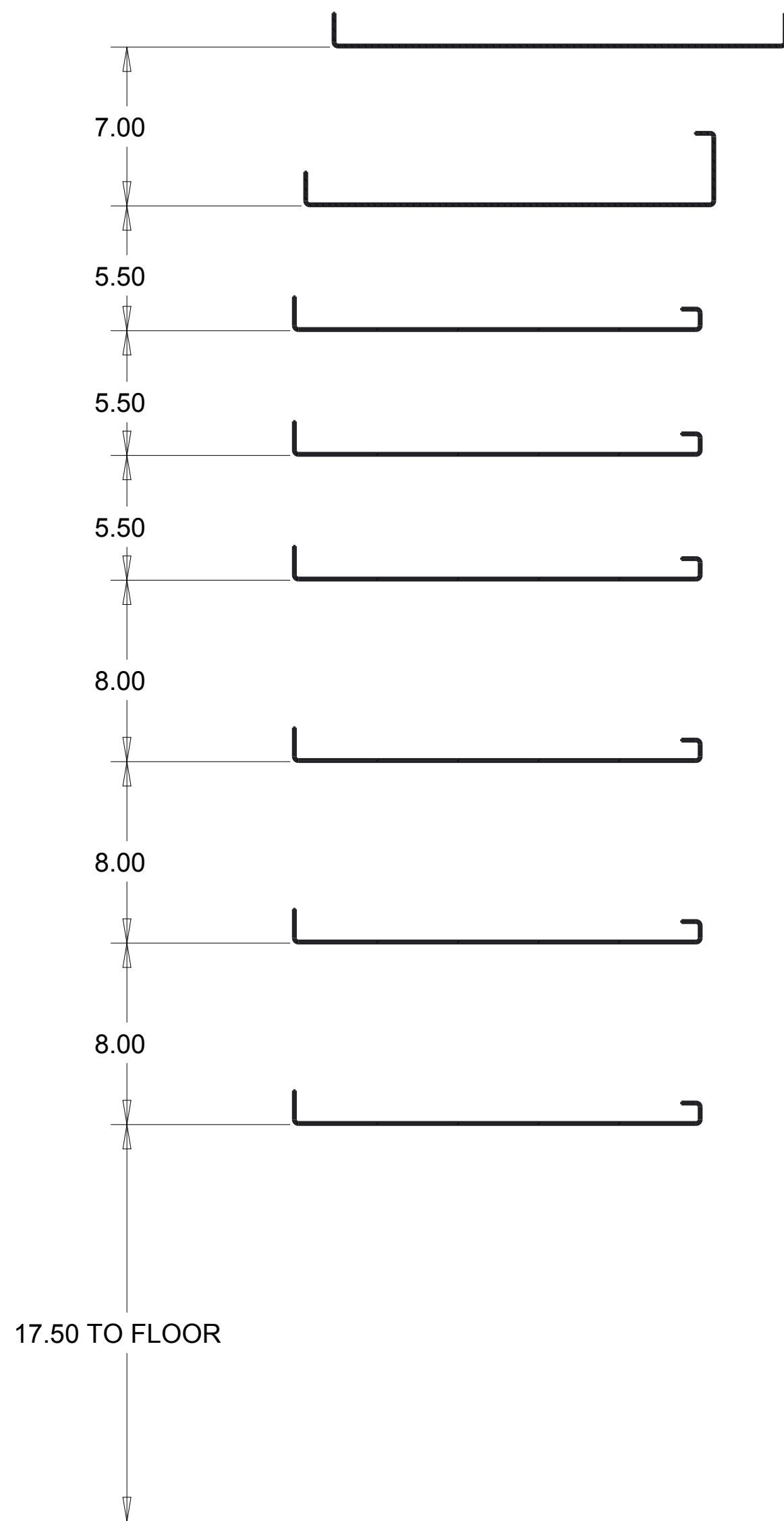

REV	REVISION DESCRIPTION	ECN	DATE	INITIALS

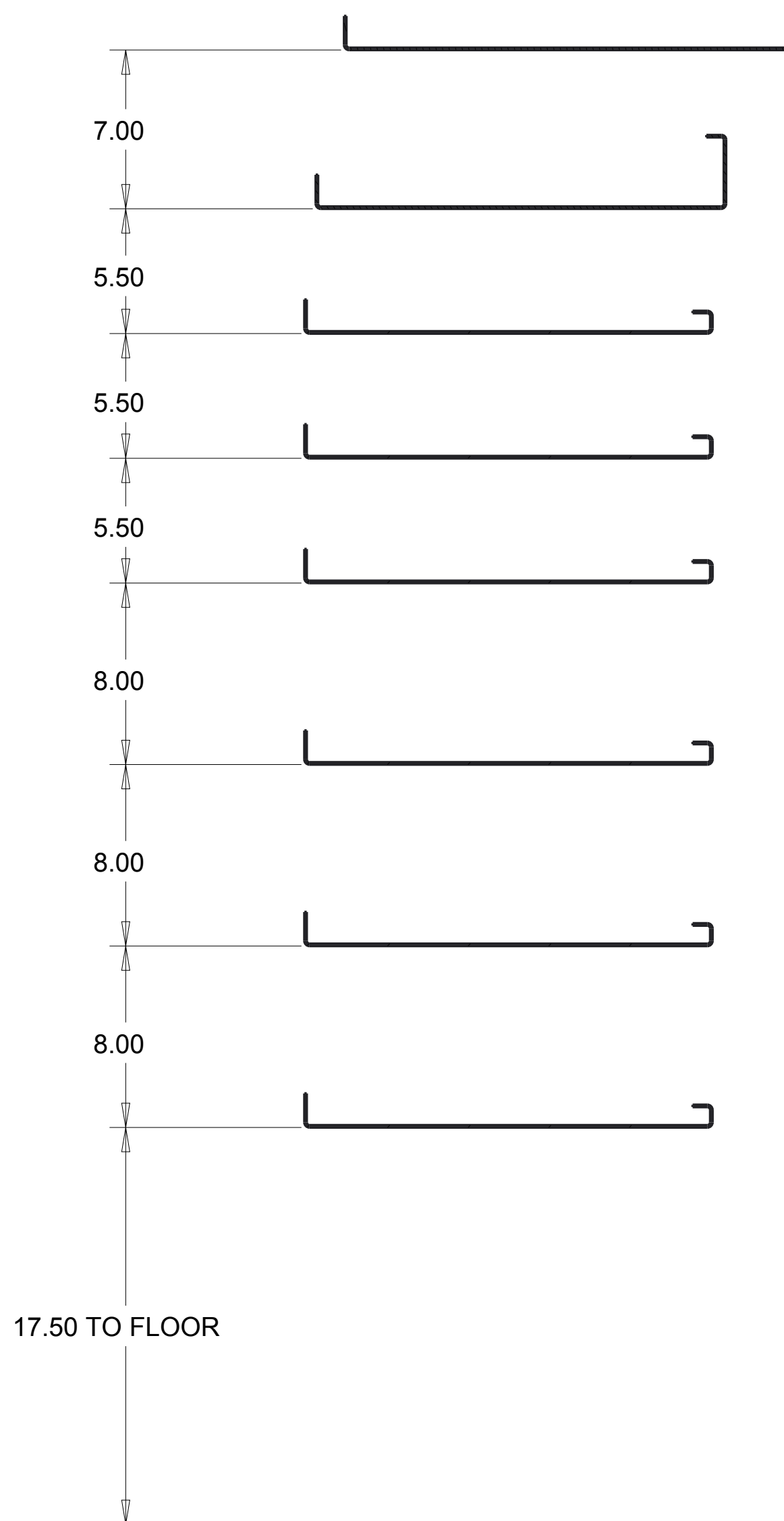

SECTION A-A
SCALE 0.175



SECTION B-B
SCALE 0.175

CNUMBER SPRINTER	WEIGHT 134.923	TOLERANCE UNLESS OTHERWISE SPECIFIED	 VT Hackney A company of VT Systems 
ROUTING FINAL	MATL CODE ZA	.XX=+/- .060 .XXX=+/- .030	
ITEM NO 386462	SHAPE DESC		252-946-6521 vtackney.com hackney.com kidron.com vtvisioncomms.com 
RAW_MATL	HRS 0.000	DESCRIPTION	
DRAWN BY ALB	DATE 30-Aug-16	SHELF ASM.- DRIVERSIDE SPRINTER 144"WB HIGH ROOF 23-46	
APPROVED BY	DATE		
SUPERSEDES	SUPERSEDED BY	SCALE 0.032	DWG NAME P16C0454 Sheet 2 of 4

BUILDUP DETAIL

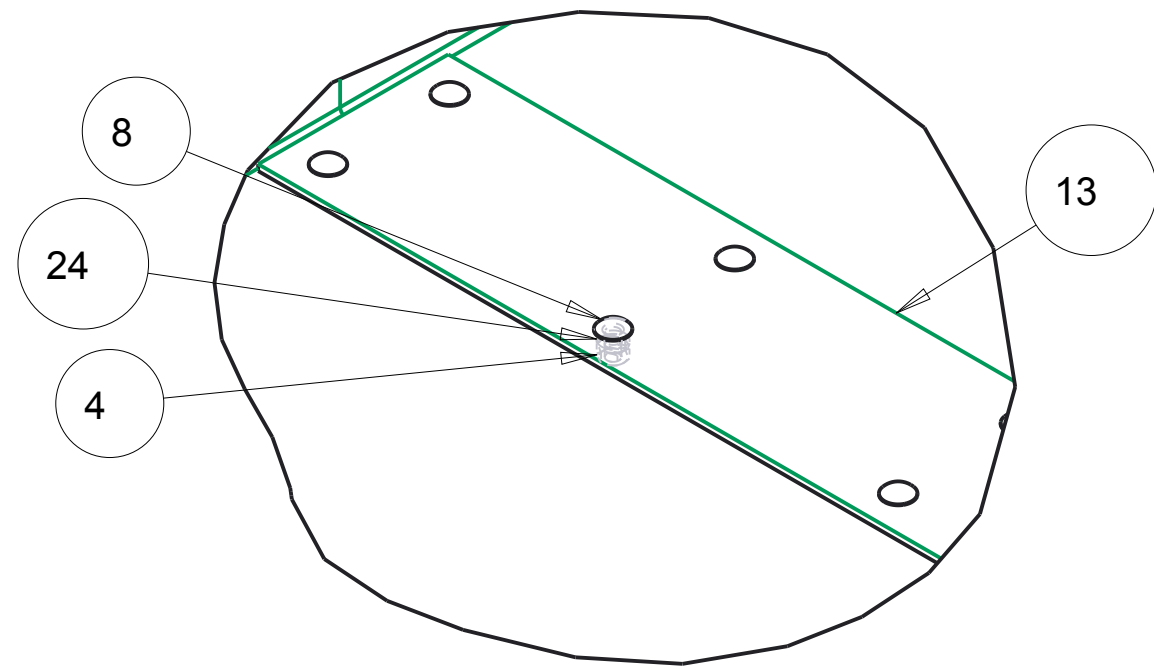

DETAIL C
SCALE 0.350

ASSEMBLY NOTE:
USER MUST MATCH DRILL (4) .38" HOLES THROUGH
LADDER SHELF MOUNT.

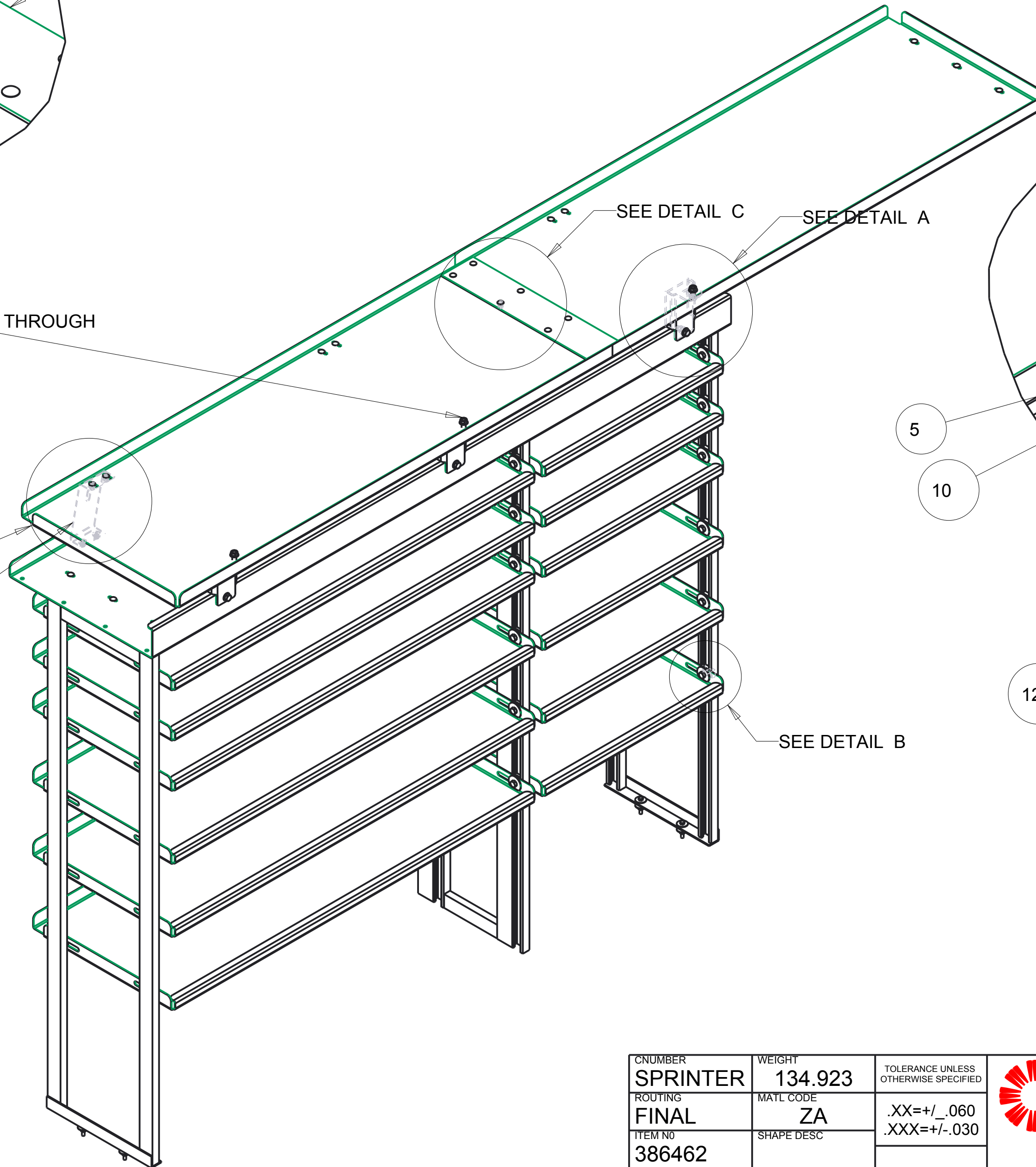

SCALE 0.125

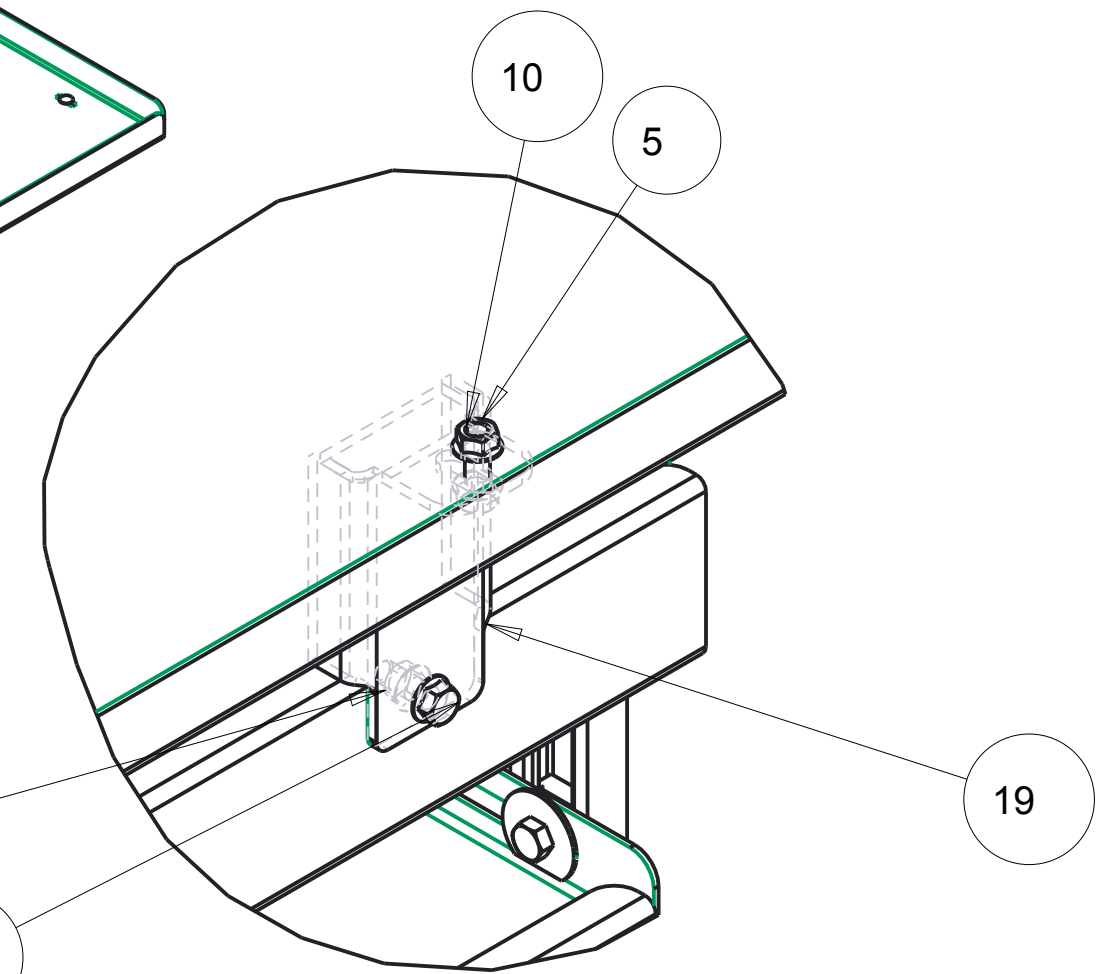

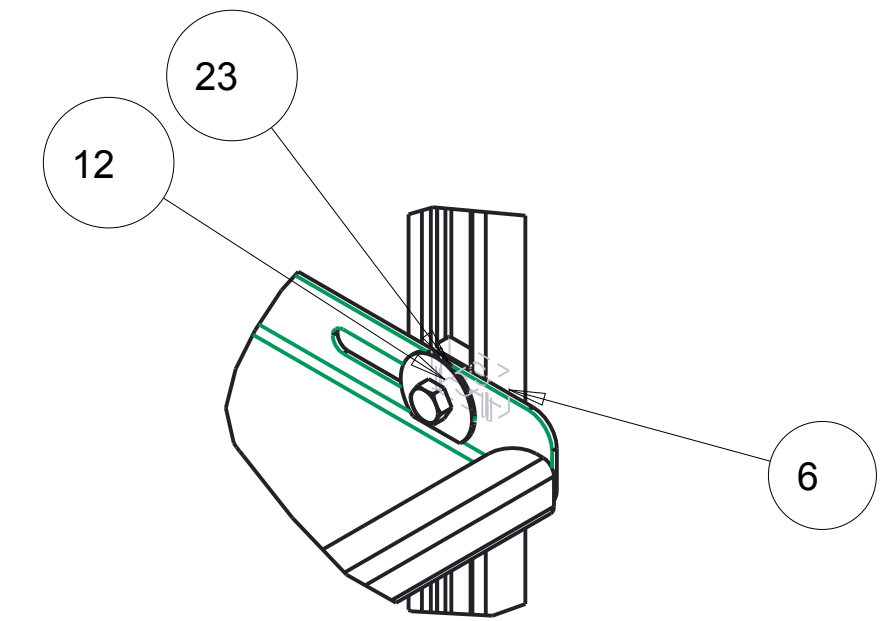

DETAIL A
SCALE 0.350

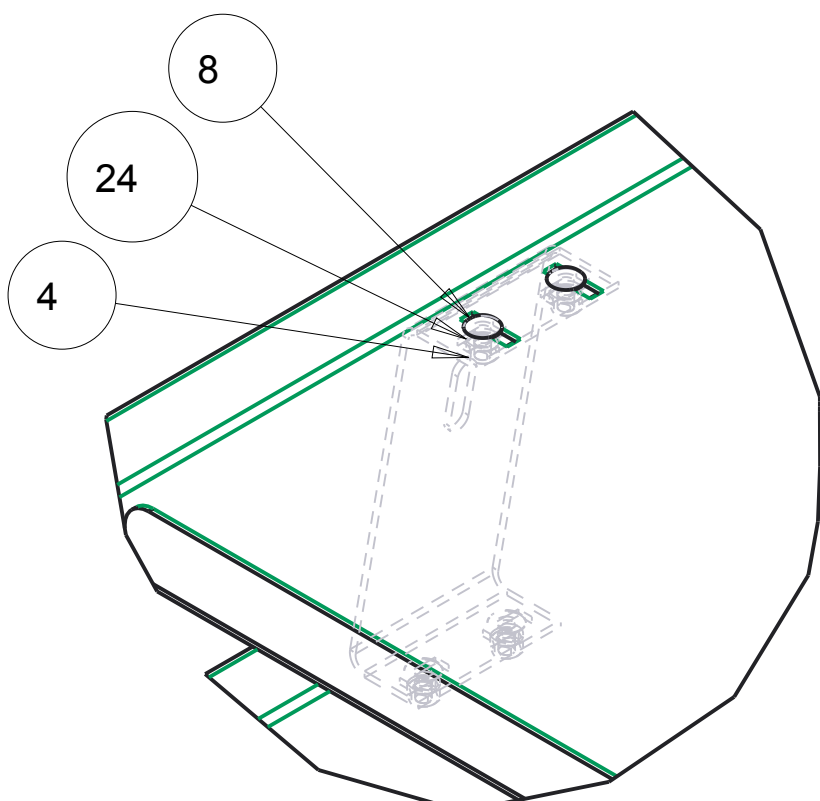

DETAIL B
SCALE 0.350



DETAIL D
SCALE 0.350

CNUMBER SPRINTER	WEIGHT 134.923	TOLERANCE UNLESS OTHERWISE SPECIFIED	 A company of VT Systems  
ROUTING FINAL	MATL CODE ZA	.XX=+/- .060 .XXX=+/- .030	
ITEM NO 386462	SHAPE DESC		252-946-6521
RAW_MATL	HRS 0.000	DESCRIPTION	vthackney.com hackney.com kidron.com vtvisioncomms.com
DRAWN BY ALB	DATE 30-Aug-16	SHELF ASM.- DRIVERSIDE SPRINTER 144"WB HIGH ROOF 23-46	
APPROVED BY	DATE	SCALE 0.032	DWG NAME P16C0454 Sheet 3 of 4
SUPERSEDES	SUPERSEDED BY		

ATTACHMENT DETAIL

INSTALLATION NOTES:

- 1.) INSTALLER RESPONSIBLE FOR SECURING SHELVING UNIT TO THE VAN USING SUPPLIED HARDWARE NOTED IN DETAILS E, F, AND G.
- 2.) BEFORE DRILLING ANY HOLE THROUGH FLOOR OR WALL, VERIFY CLEARANCE ON BACKSIDE OF HOLE.

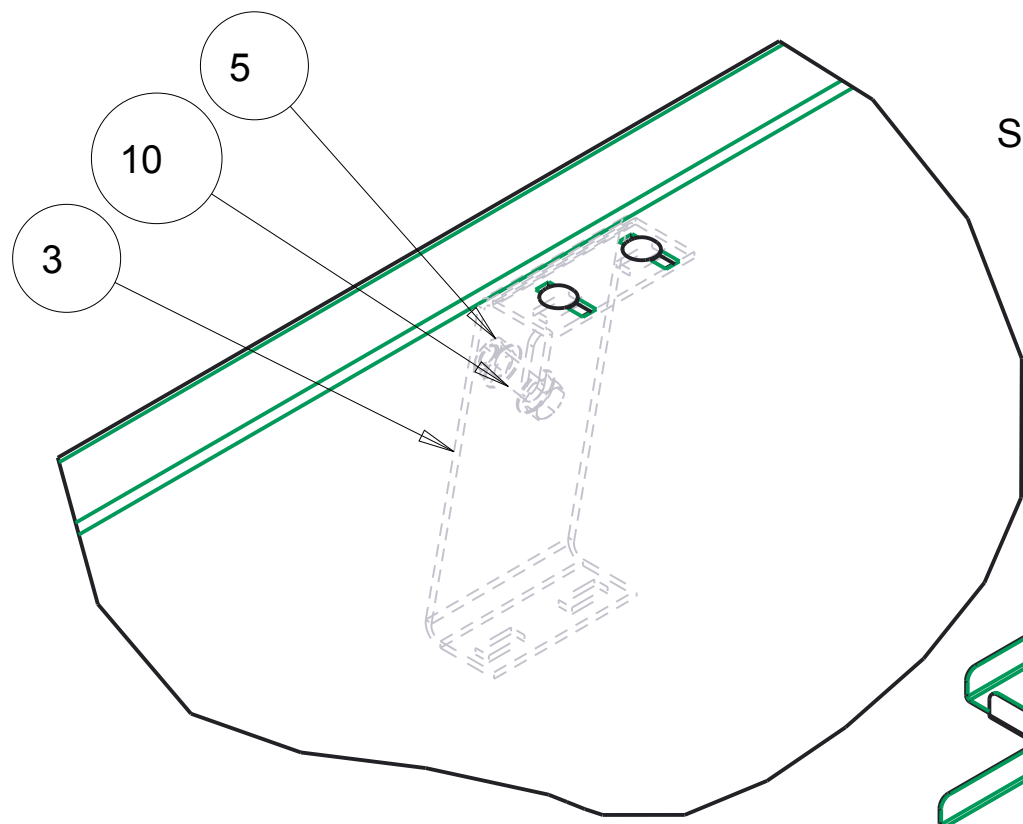

DETAIL F
SCALE 0.350

SEE DETAIL F

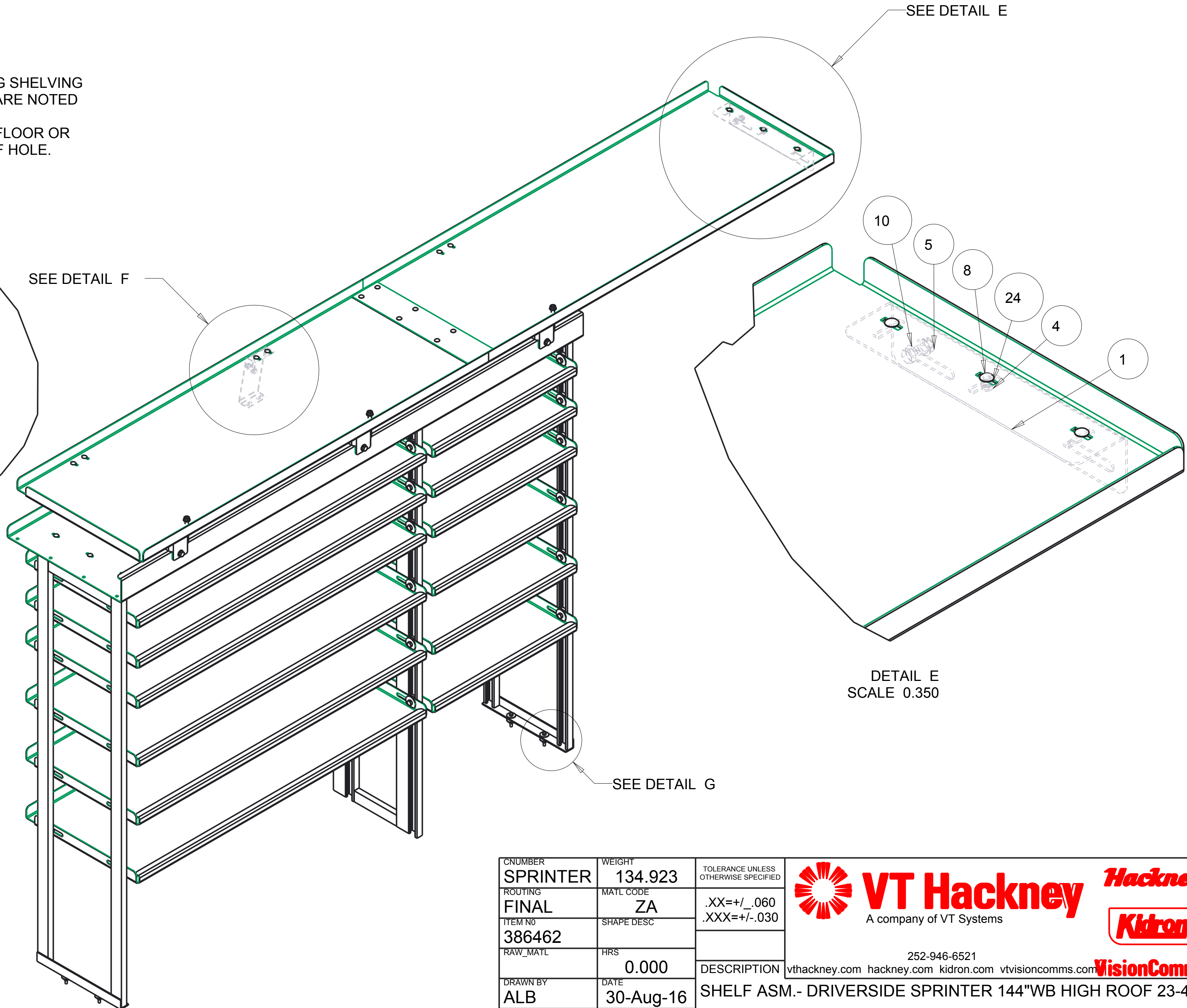

DETAIL E
SCALE 0.350

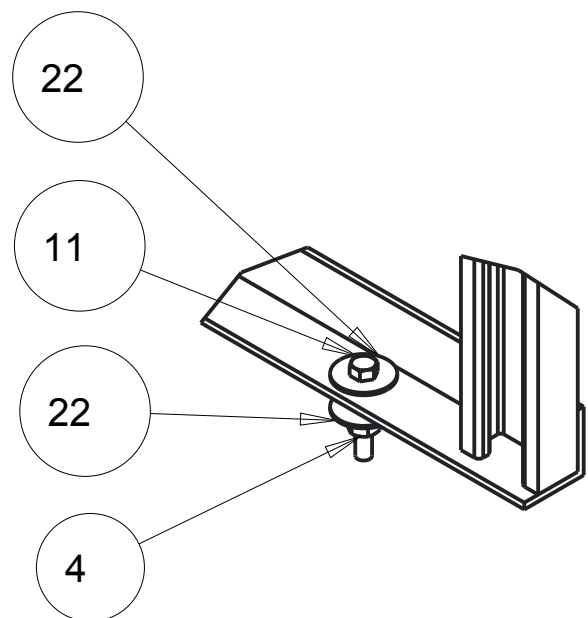

DETAIL G
SCALE 0.350

SCALE 0.125

NUMBER SPRINTER	WEIGHT 134.923	TOLERANCE UNLESS OTHERWISE SPECIFIED	 A company of VT Systems
ROUTING FINAL	MATL CODE ZA	.XX=+/- .060 .XXX=+/- .030	
ITEM NO 386462	SHAPE DESC		252-946-6521 vtackney.com hackney.com kidron.com vtvisioncomms.com
RAW_MATL	HRS 0.000	DESCRIPTION	
DRAWN BY ALB	DATE 30-Aug-16	SHELF ASM.- DRIVERSIDE SPRINTER 144"WB HIGH ROOF 23-46	
APPROVED BY	DATE	SCALE 0.032	DWG NAME P16C0454 Sheet 4 of 4
SUPERSEDES	SUPERSEDED BY		

Hackney

Kidron

VisionComms