

NOTE:
1. FOR OPTIONAL SHELF LINER KIT, USE #386539

BBL NO.	ITEM DESCRIPTION	LENGTH	WIDTH	WEIGHT	MATL CODE	QTY REQD	ITEM NO.	MODEL NAME
1	ANGLE-.10X1.50X1.50X 13.25	13.250	2.810	0.334	BB2	4	385287	P15C0410
2	ANGLE-.10X1.50X1.50X 16.75	16.750	3.310	0.534	BB2	3	386528	386528
3	ANGLE-.12X1.25X1.25X 3.00	3.000	2.472	0.084	BB1	4	385505	385505
4	NUT-HEX .25 SST			0.007	E1	22	807862	807862
5	NUT-HEX 0.38 LK			0.018	E1	4	1485	1485
6	NUT-UNISTRUT W/O SPRING .38-16			0.086	C4	80	802807	802807
7	SCREW-CARRIAGE .25X .50			0.014	E0	18	826255	826255
8	SCREW-HEX 3/8-13X 1.00 FLANGE			0.059	E1	4	1490	1490
9	SCREW-HEX. LAG 31X 1.25 FLANGE	1.280		0.042	E0	8	811914	811914
10	SCREW-HEX.25X1.50 SST			0.027	E0	4	803172	803172
11	SCREW-HEX.38X .75 GR5	0.750		0.043	E0	80	802804	802804
12	SHELF-TOP 18"x90.38"	90.380	18.000	14.637	BB2	1	386540	P17C0013
13	SHELF-TRAY 18"x18"	18.000	18.000	3.978	BB2	6	324703	SHELF3_DS
14	SHELF-TRAY 18"x23"	23.000	18.000	4.981	BB2	6	386376	SHELF1_DS_D
15	SHELF-TRAY 18"x46"	46.000	18.000	9.633	BB2	3	385297	SHELF2_DS_D
16	SHELF-TRAY 18"x46" NOTCH	46.000	18.000	9.131	BB2	3	386516	SHELF2_DS_S
17	UNISTRUT ASM-DOUBLE			9.296	ZA	1	385522	385522
18	UNISTRUT ASM-DOUBLE SP WW			9.296	ZA	1	386535	386535
19	UNISTRUT ASM-SINGLE			6.141	ZA	2	385500	385500
20	WASHER-FENDER .25 SST			0.009	E2	8	820746	820746
21	WASHER-FLAT .38 D-SHAPED			0.007	E2	80	816154	816154
22	WASHER-LOCK .25 SST			0.002	E2	22	803630	803630

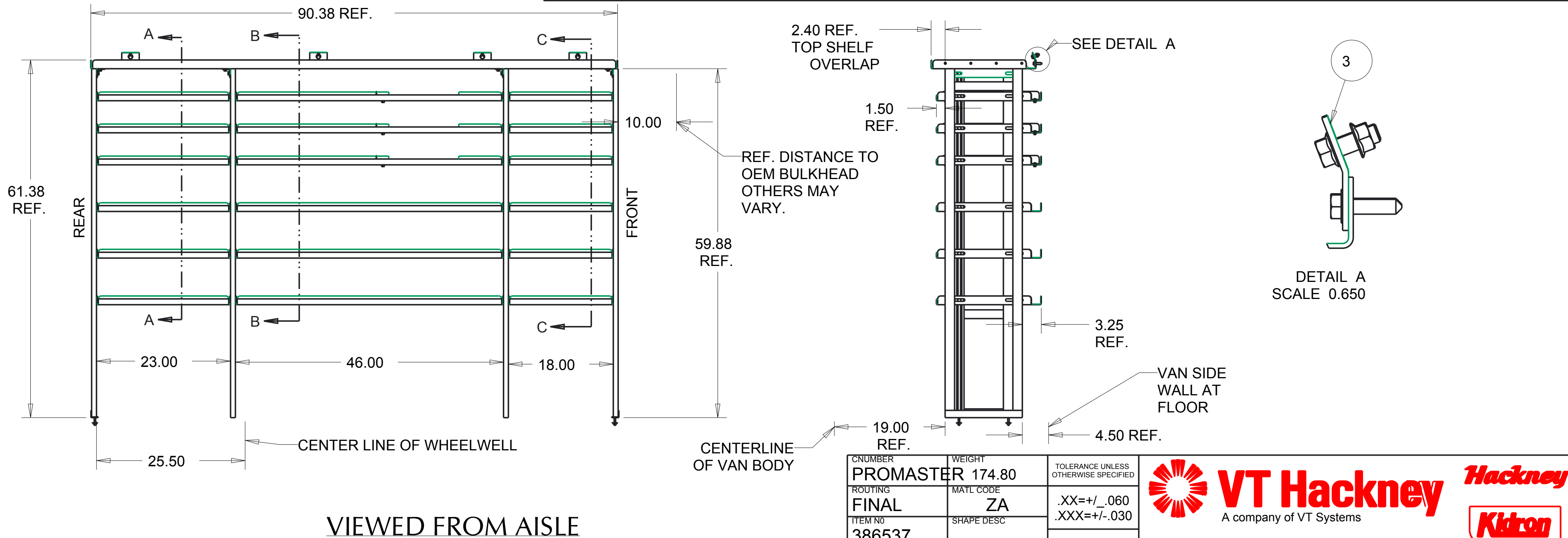

VIEWED FROM AISLE

CNUMBER	WEIGHT	TOLERANCE UNLESS OTHERWISE SPECIFIED
PROMASTER	174.80	
ROUTING	MATL CODE	.XX=+/- .060
FINAL	ZA	.XXX=+/- .030
ITEM NO	SHAPE DESC	
386537		
RAW_MATL	HRS	
	0.000	
DRAWN BY	DATE	DESCRIPTION
LRE	Jan-12-17	vthackney.com hackney.com kidron.com vtvisioncomms.com
APPROVED BY	DATE	
SUPERSEDES	SUPERSEDED BY	SCALE
		0.080

VT Hackney *Hackney*
A company of VT Systems

252-946-6521
vtvisioncomms.com *VisionComms*

Kidron

SHELF ASM.- DRIVERSIDE PROMASTER 136" WB HIGH ROOF 23-46-18

THIS PRINT AND ALL RIGHTS TO THE DESIGN AND DETAIL THEREON ARE THE PROPERTY OF VT HACKNEY AND IS LOANED TO THE RECIPIENT SUBJECT TO RETURN UPON DEMAND. ITS CONTENTS ARE CONFIDENTIAL AND MUST NOT BE COPIED OR SUBMITTED TO OUTSIDE PARTIES FOR USE OR EXAMINATION. COPYRIGHT 2017 VT HACKNEY A COMPANY OF VT SYSTEMS

REV	REVISION DESCRIPTION	ECN	DATE	INITIALS

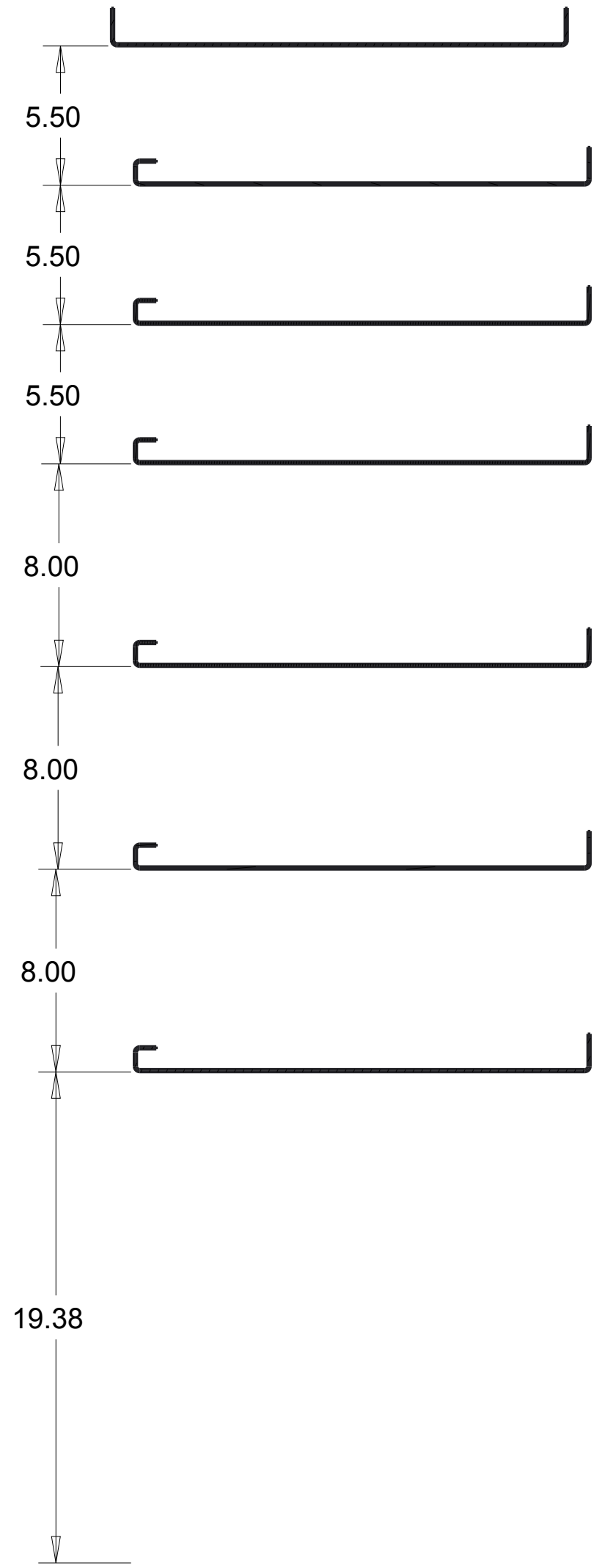



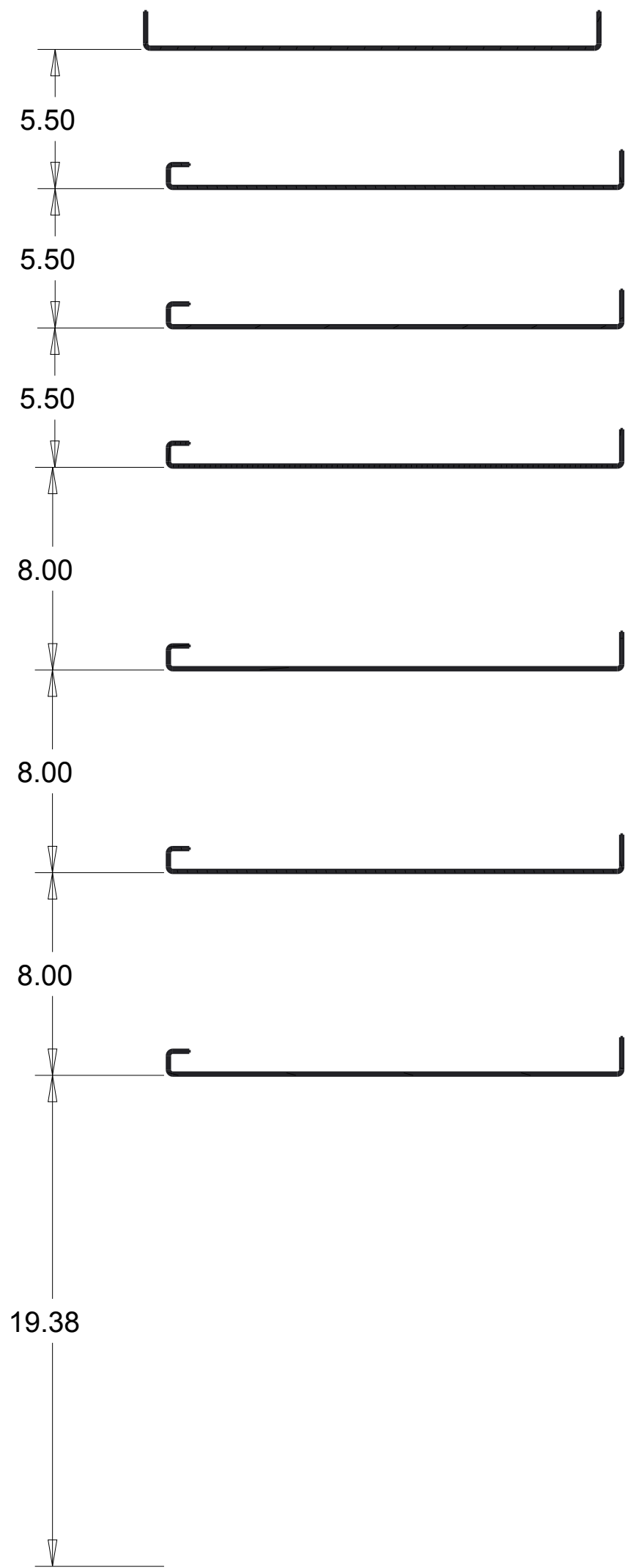

SECTION A-A

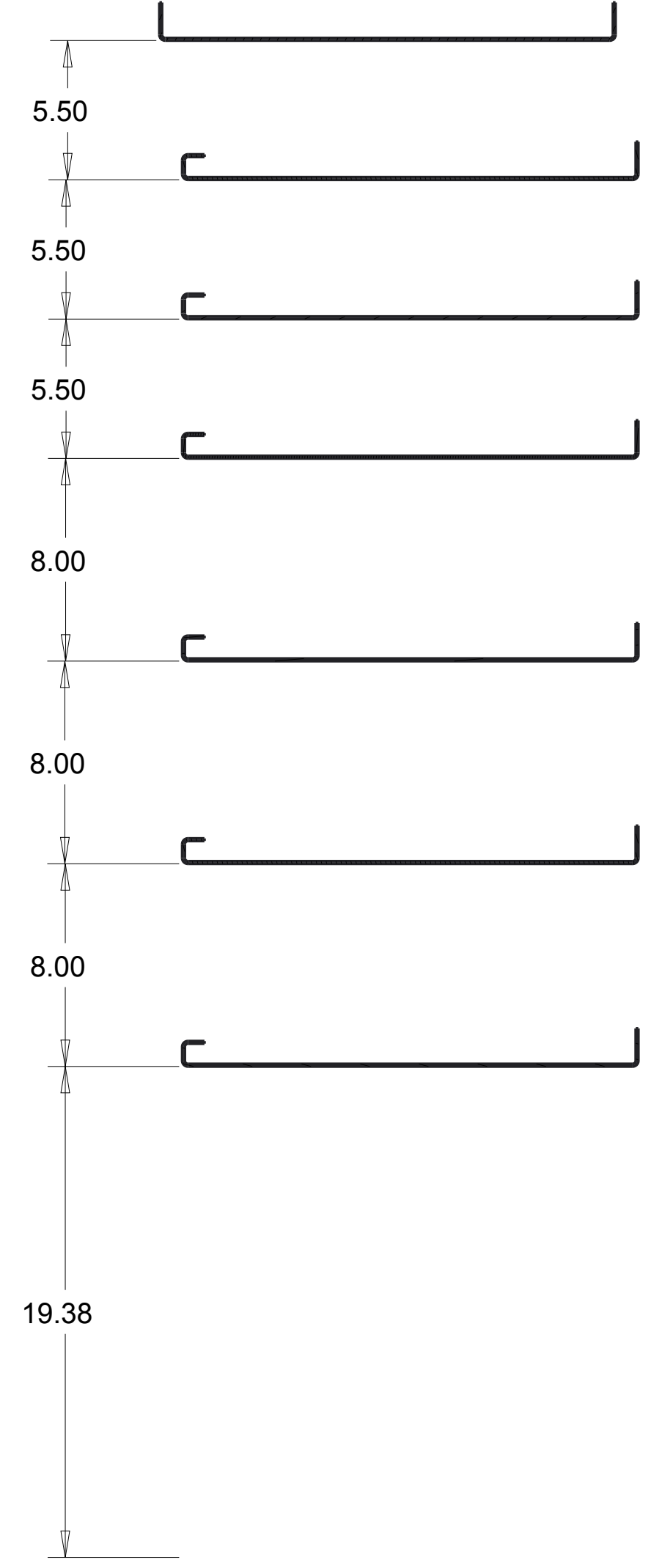

SECTION B-B



SECTION C-C

CNUMBER	WEIGHT	TOLERANCE UNLESS OTHERWISE SPECIFIED	 VT Hackney A company of VT Systems	  
ROUTING	MATL CODE			
FINAL	ZA	.XX=+/- .060 .XXX=+/- .030	252-946-6521 vtackney.com hackney.com kidron.com vtvisioncomms.com	SHELF ASM.- DRIVERSIDE PROMASTER 136" WB HIGH ROOF 23-46-18
ITEM NO	SHAPE DESC			
386537				
RAW_MATL	HRS			
	0.000			
DRAWN BY	DATE			
LRE	Jan-13-17			
APPROVED BY	DATE			
SUPERSEDES	SUPERSEDED BY	SCALE	DWG NAME	
		0.180		P16C0688 Sheet 2 of 4

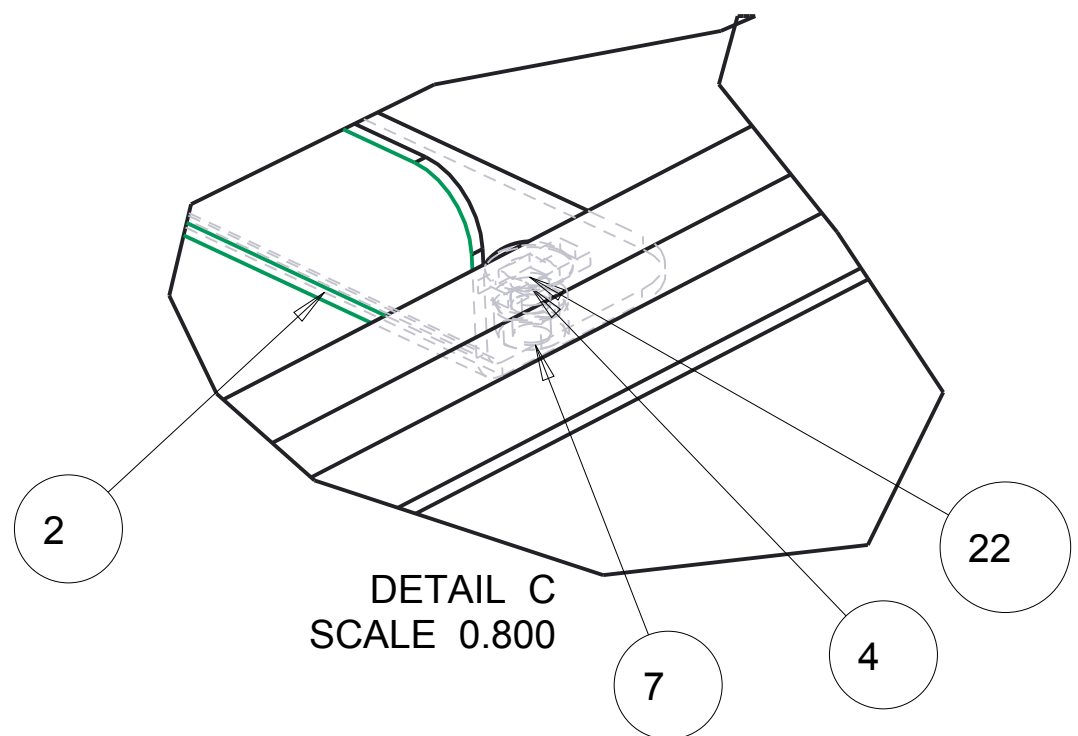

SEE DETAIL B

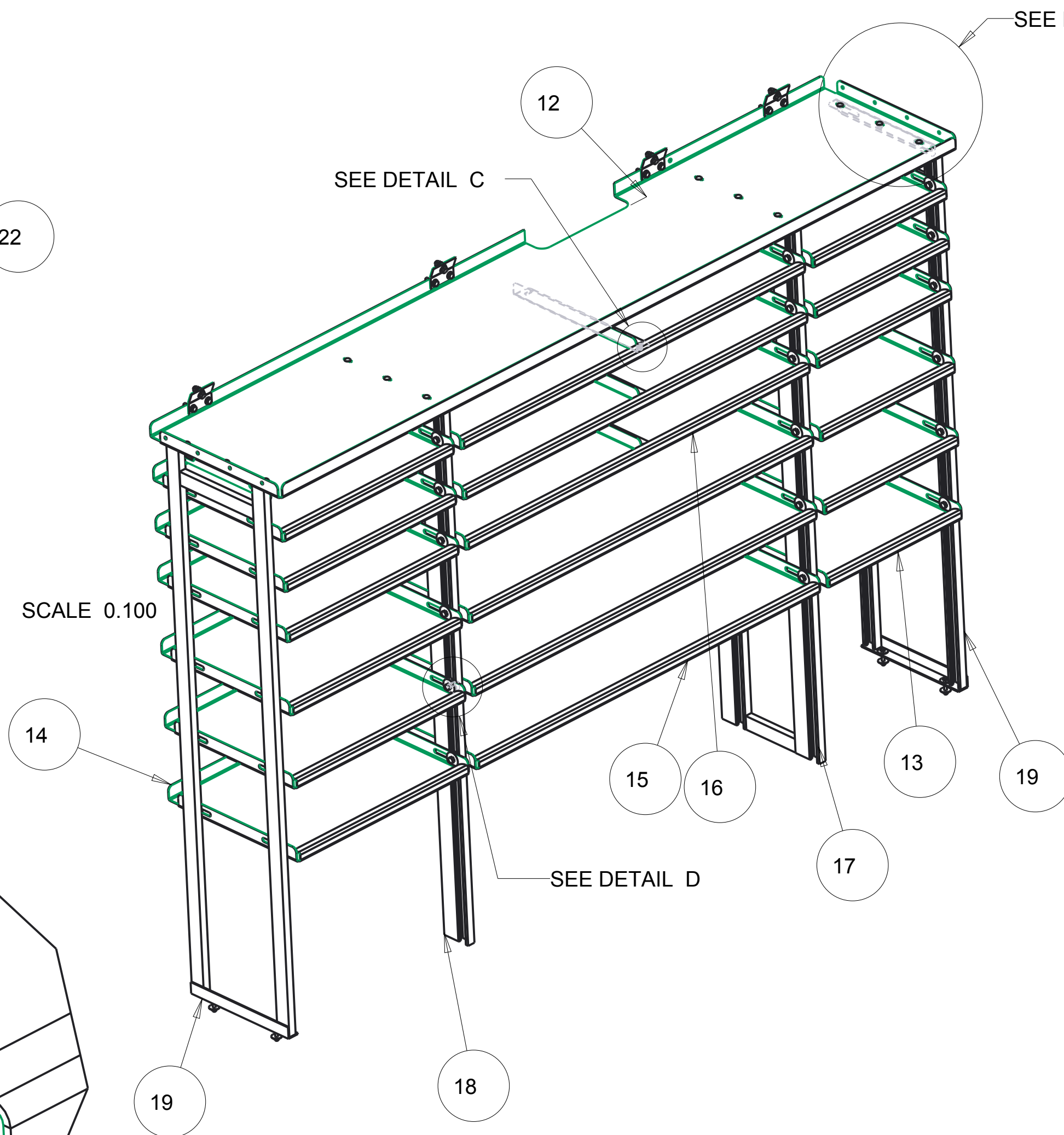
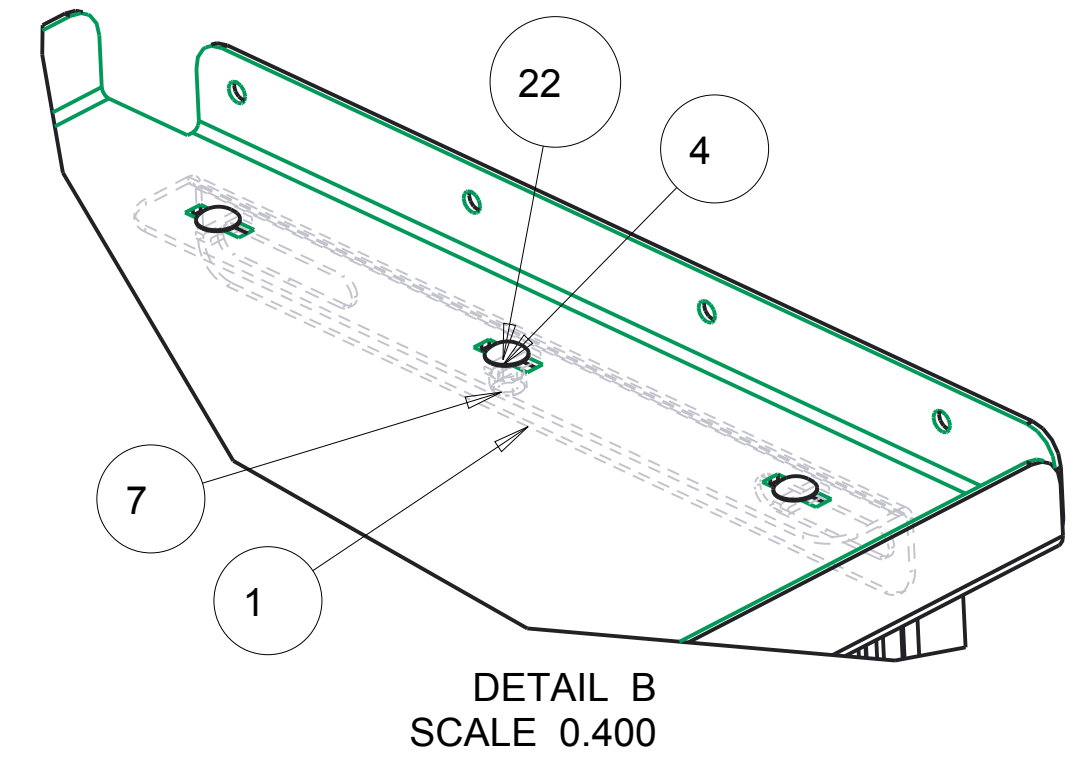

SEE DETAIL C

SEE DETAIL D

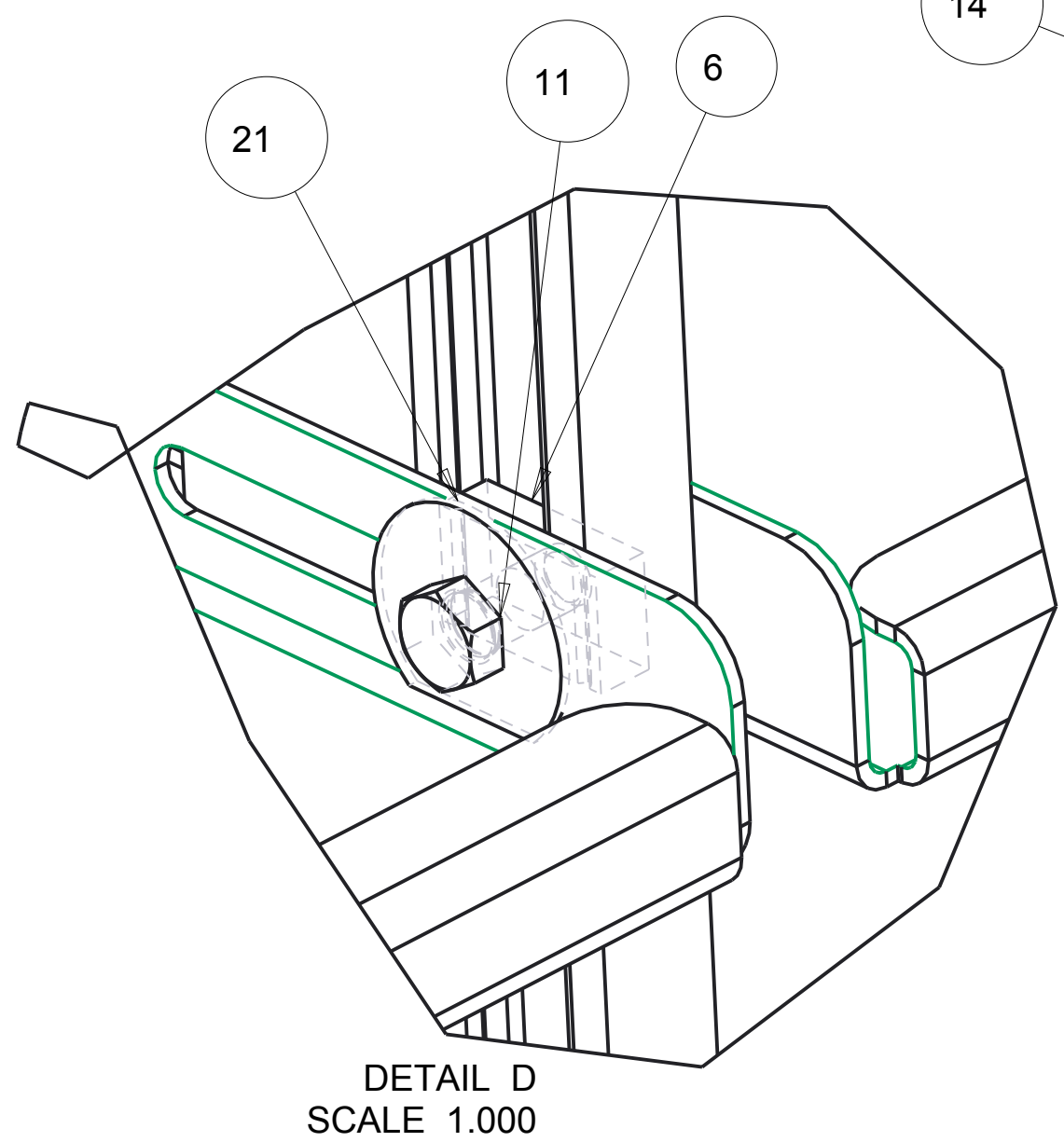

CNUMBER	WEIGHT	TOLERANCE UNLESS OTHERWISE SPECIFIED
PROMASTER	174.80	
ROUTING	MATL CODE	.XX=+/- .060
FINAL	ZA	.XXX=+/- .030
ITEM NO	SHAPE DESC	
386537		
RAW_MATL	HRS	
	0.000	
DRAWN BY	DATE	DESCRIPTION
LRE	Jan-13-17	SHELF ASM.- DRIVERSIDE PROMASTER 136" WB HIGH
APPROVED BY	DATE	ROOF 23-46-18
SUPERSEDES	SUPERSEDED BY	SCALE
		0.080
		DWG NAME

VT Hackney *Hackney*
 A company of VT Systems *Kidron*

252-946-6521
 vtackney.com hackney.com kidron.com vtvisioncomms.com *VisionComms*

ATTACHMENT DETAILS

* DRILL 3/8" HOLE THRU VAN WALL FLANGE AREA AFTER LAG SCREWS ARE INSTALLED

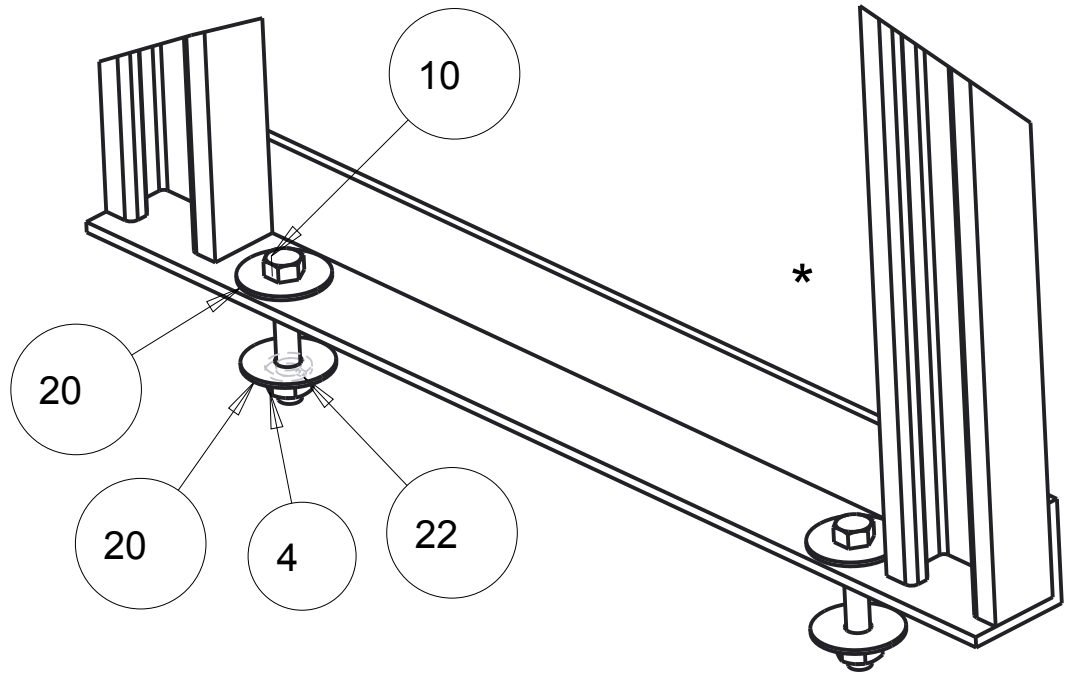

DETAIL F
SCALE 0.500

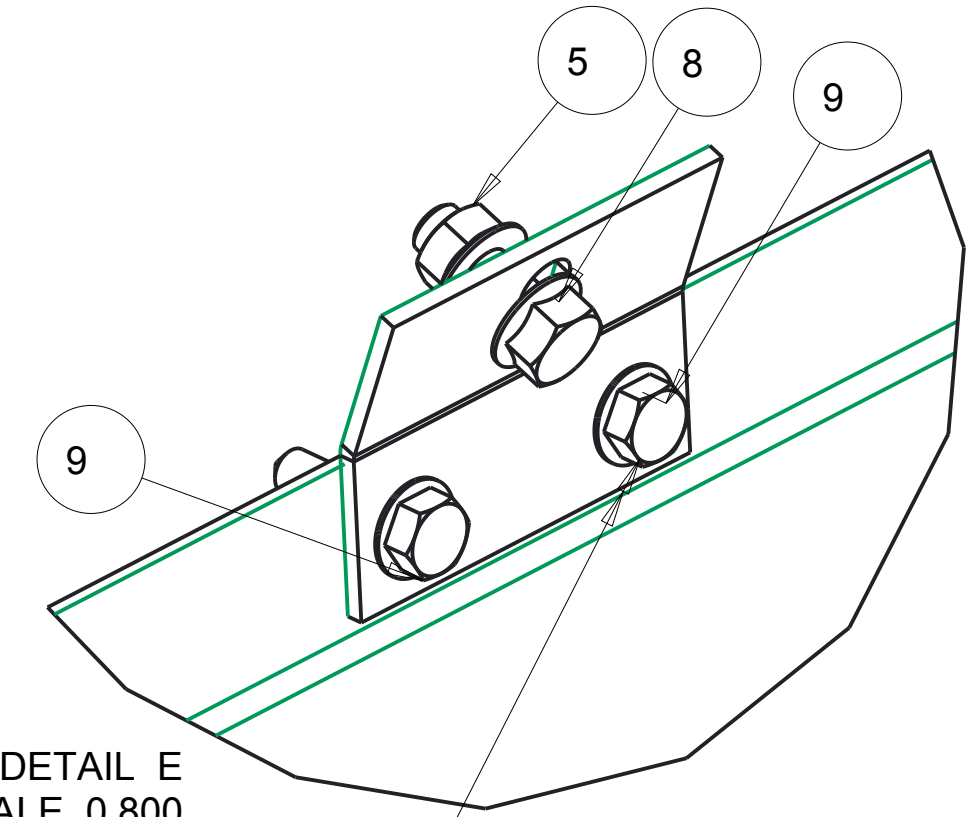

DETAIL E
SCALE 0.800

* MATCH HOLES IN ANGLE TO SHELF FLANGE, THEN DRILL 1/4" PILOT HOLES THRU VAN WALL, INSTALL 5-16" LAG SCREWS, DO NOT OVER TIGHTEN.

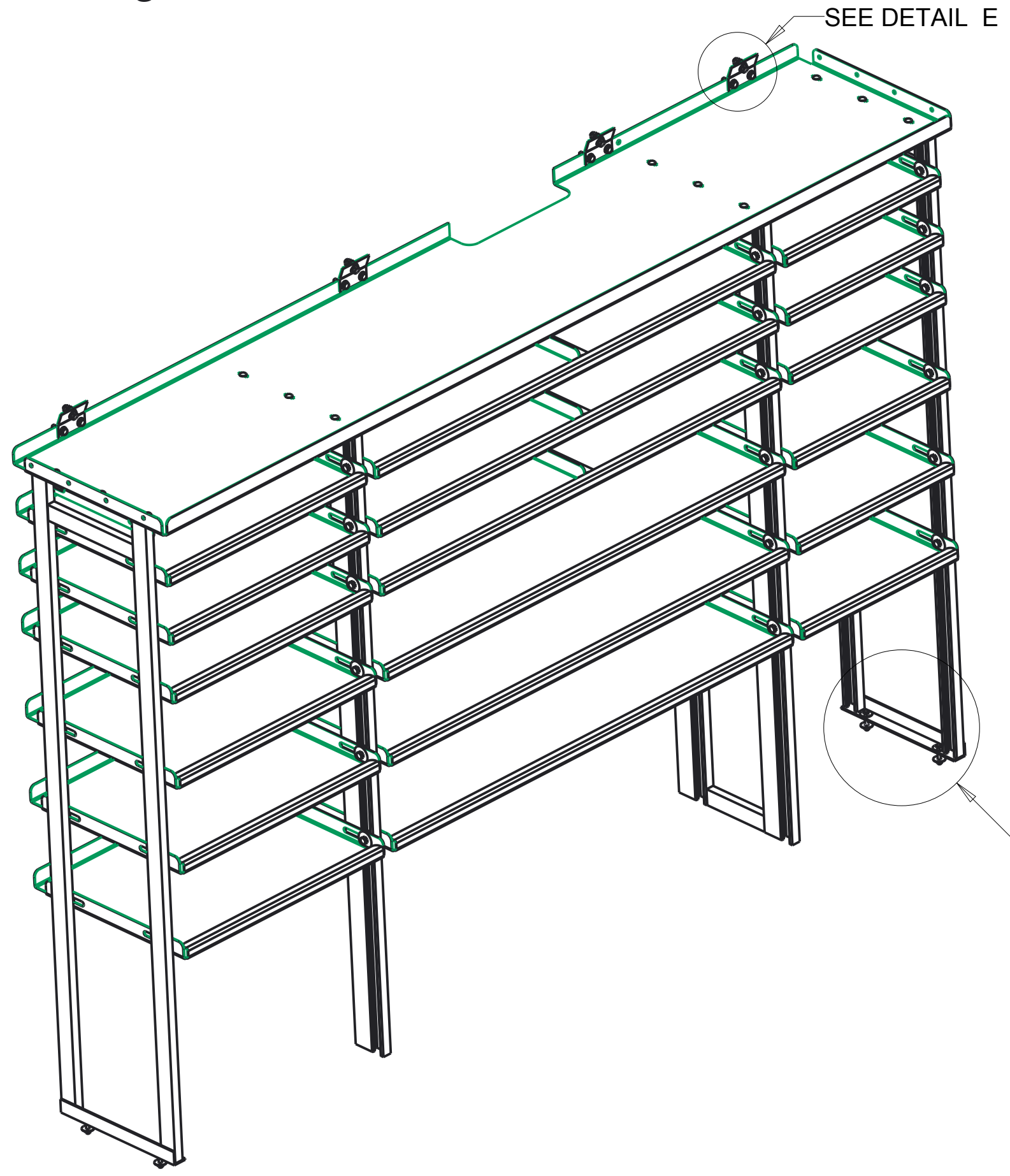

SCALE 0.100

SEE DETAIL F

* NOTE:
BEFORE DRILLING ANY HOLE THROUGH THE FLOOR OR WALL, VERIFY CLEARANCE ON BACKSIDE OF HOLE.

NUMBER	WEIGHT	TOLERANCE UNLESS OTHERWISE SPECIFIED
PROMASTER	174.80	
ROUTING	MATL CODE	
FINAL	ZA	.XX=+/- .060 .XXX=+/- .030
ITEM NO	SHAPE DESC	
386537		
RAW_MATL	HRS	
	0.000	
DRAWN BY	DATE	DESCRIPTION
LRE	Jan-13-17	SHELF ASM.- DRIVERSIDE PROMASTER 136" WB HIGH ROOF 23-46-18
APPROVED BY	DATE	
SUPERSEDES	SUPERSEDED BY	SCALE
		0.080
		DWG NAME



252-946-6521
vthackney.com hackney.com kidron.com vtvisioncomms.com

