

NOTE:
1. FOR OPTIONAL SHELF LINER KIT, USE #386543

BBL NO.	ITEM DESCRIPTION	LENGTH	WIDTH	WEIGHT	MATL CODE	QTY REQD	ITEM NO.	MODEL NAME
1	ANGLE-.10X1.50X1.50X 13.25	13.250	2.810	0.334	BB2	2	385287	P15C0410
2	ANGLE-.12X1.25X1.25X 3.00	3.000	2.472	0.084	BB1	3	385505	385505
3	NUT-HEX .25 SST			0.007	E1	10	807862	807862
4	NUT-HEX .38 LK			0.018	E1	3	1485	1485
5	NUT-UNISTRUT W/O SPRING .38-16			0.086	C4	28	802807	802807
6	SCREW-CARRIAGE .25X .50			0.014	E0	6	826255	826255
7	SCREW-HEX 3/8-13X 1.00 FLANGE			0.059	E1	3	1490	1490
8	SCREW-HEX. LAG 31X 1.25 FLANGE	1.280		0.042	E0	6	811914	811914
9	SCREW-HEX.25X1.50 SST			0.027	E0	4	803172	803172
10	SCREW-HEX.38X .75 GR5	0.750		0.043	E0	28	802804	802804
11	SHELF-TOP 18"x47.75"	47.875	18.000	14.637	BB2	1	386541	P17C0034
12	SHELF-TRAY 18"x46"	46.000	18.000	9.633	BB2	6	385297	SHELF1_DS
13	UNISTRUT ASM-SINGLE			6.141	ZA	2	385500	385500
14	WASHER-FENDER .25 SST			0.009	E2	8	820746	820746
15	WASHER-FLAT .38 D-SHAPED			0.007	E2	28	816154	816154
16	WASHER-LOCK .25 SST			0.002	E2	10	803630	803630

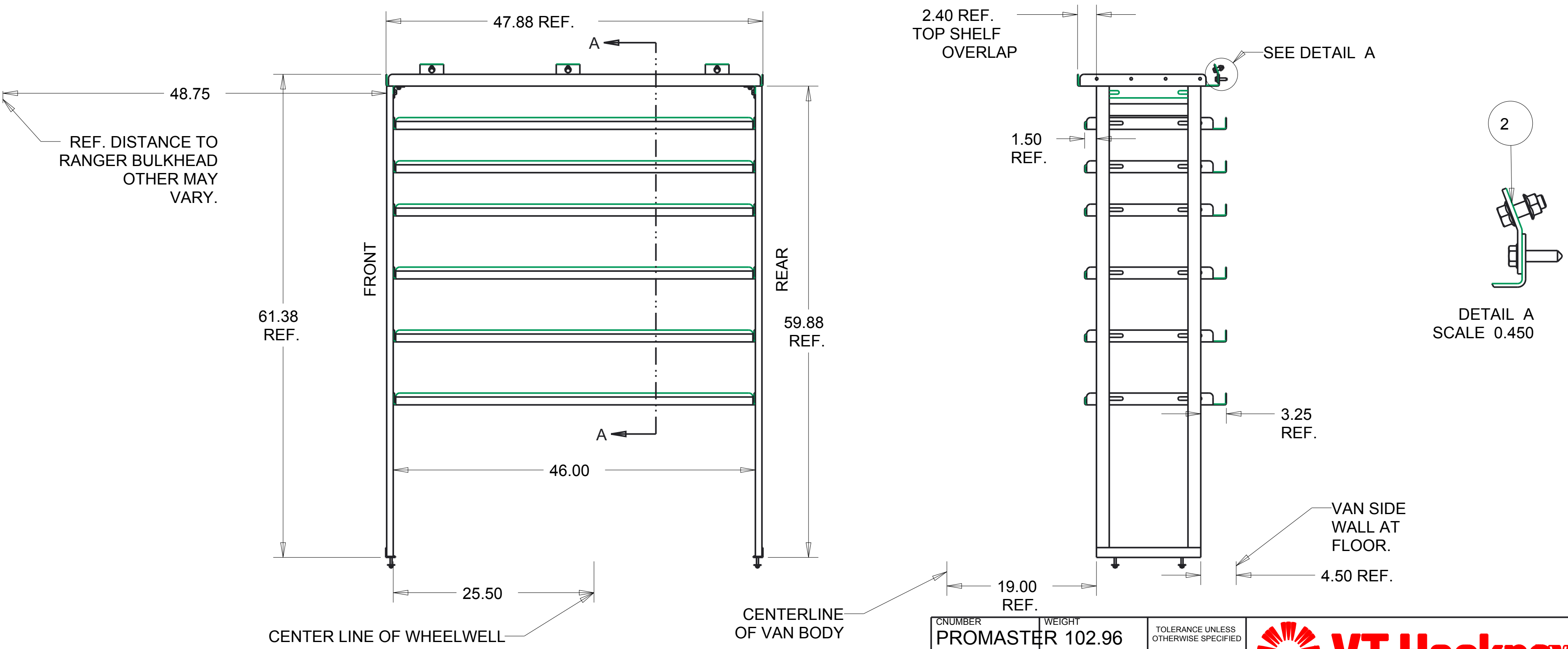

VIEWED FROM AISLE

NUMBER	WEIGHT	TOLERANCE UNLESS OTHERWISE SPECIFIED
PROMASTER 102.96		
ROUTING	MATL CODE	.XX=+/- .060 .XXX=+/- .030
FINAL	ZA	
ITEM NO	SHAPE DESC	
386538		
RAW_MATL	HRS	
	0.000	
DRAWN BY	DATE	DESCRIPTION
LRE	Jan-20-17	vthackney.com hackney.com kidron.com vtvisioncomms.com
APPROVED BY	DATE	
SUPERSEDES	SUPERSEDED BY	SCALE
		0.100
		DWG NAME

VT Hackney *Hackney*
A company of VT Systems

252-946-6521
vthackney.com hackney.com kidron.com vtvisioncomms.com



Kidron
VisionComms

SHELF ASM. -CURBSIDE PROMASTER 136"
HIGH ROOF 46"

THIS PRINT AND ALL RIGHTS TO THE DESIGN AND DETAIL THEREON ARE THE PROPERTY OF VT HACKNEY AND IS LOANED TO THE RECIPIENT SUBJECT TO RETURN UPON DEMAND. ITS CONTENTS ARE CONFIDENTIAL AND MUST NOT BE COPIED OR SUBMITTED TO OUTSIDE PARTIES FOR USE OR EXAMINATION. COPYRIGHT 2017 VT HACKNEY A COMPANY OF VT SYSTEMS

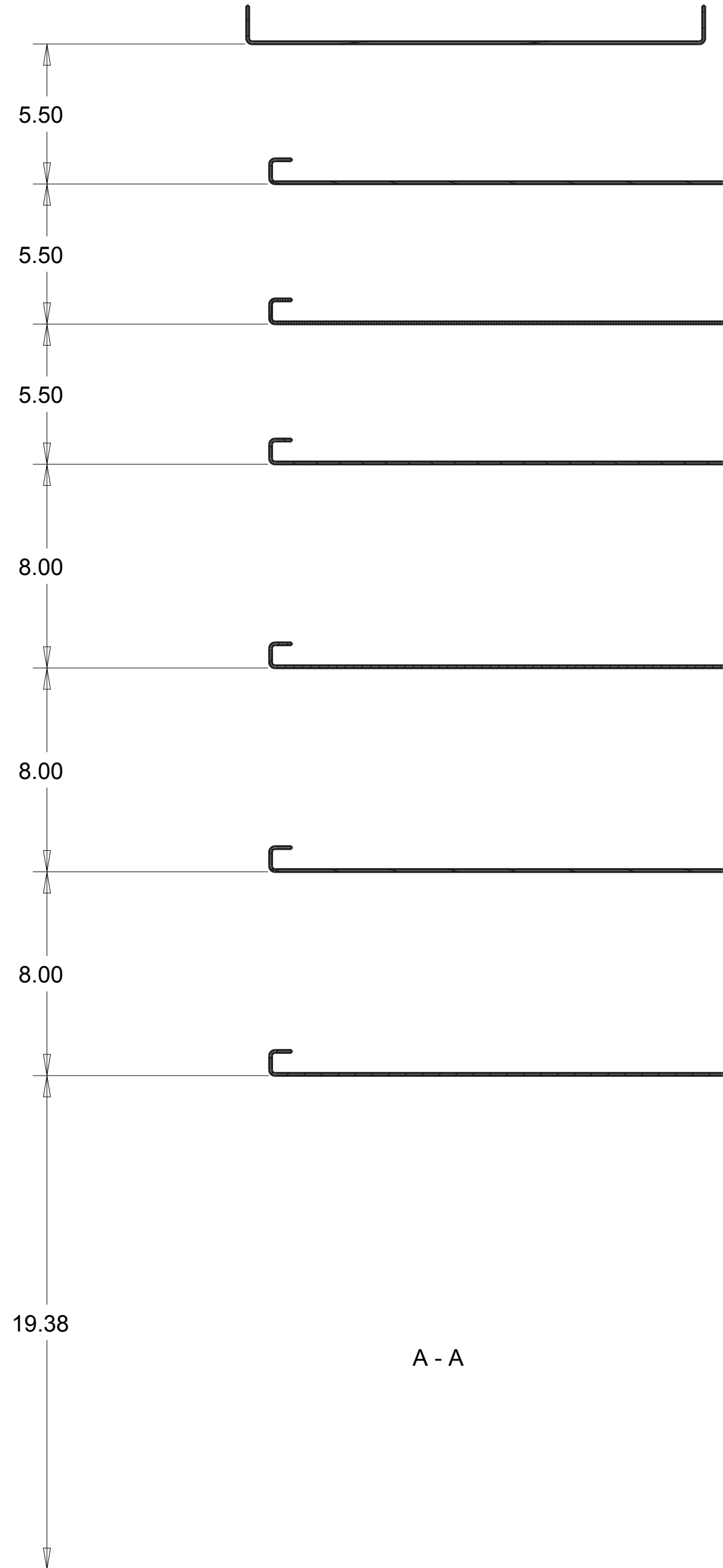
REV	REVISION DESCRIPTION	ECN	DATE	INITIALS



CNUMBER	WEIGHT	TOLERANCE UNLESS OTHERWISE SPECIFIED	 VT Hackney <i>Hackney</i> A company of VT Systems  252-946-6521 vtackney.com hackney.com kidron.com vtvisioncomms.com VisionComms
ROUTING	MATL CODE		
ITEM NO	SHAPE DESC		
RAW_MATL	HRS	DESCRIPTION	
DRAWN BY	DATE		
APPROVED BY	DATE		
SUPERSEDES	SUPERSEDED BY	SCALE	DWG NAME
PROMASTER	102.96		
FINAL	ZA	.XX=+/- .060 .XXX=+/- .030	
386538			
	0.000		
LRE	Jan-20-17	SHELF ASM. -CURBSIDE PROMASTER 136" HIGH ROOF 46"	
		0.225	P16C0687 Sheet 2 of 4

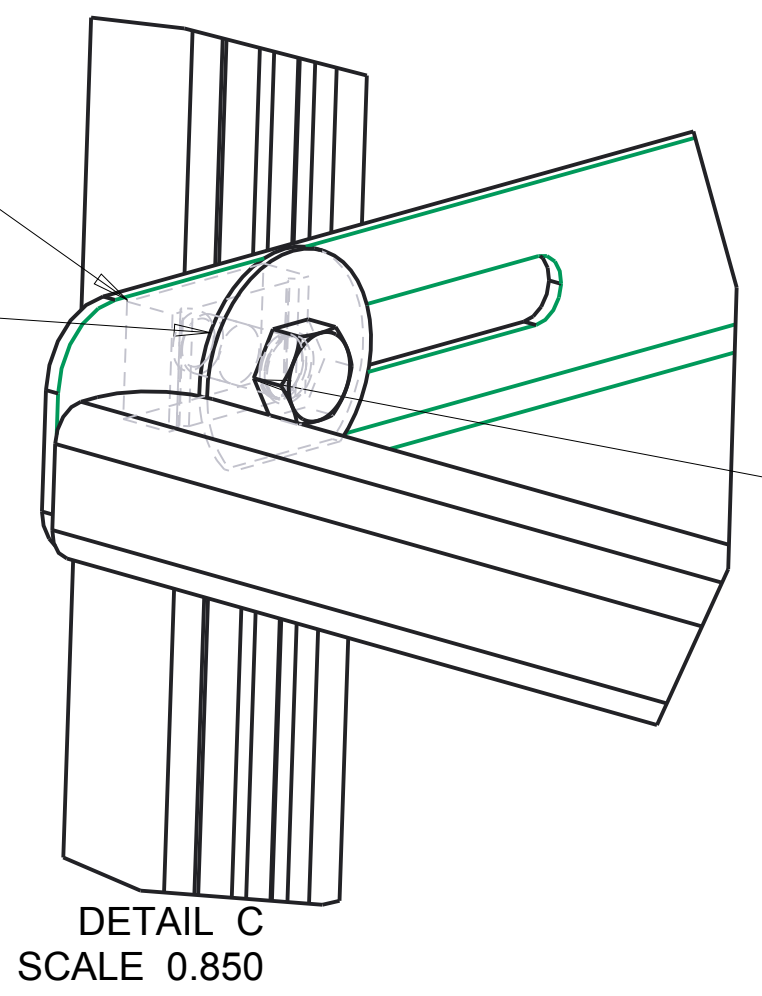
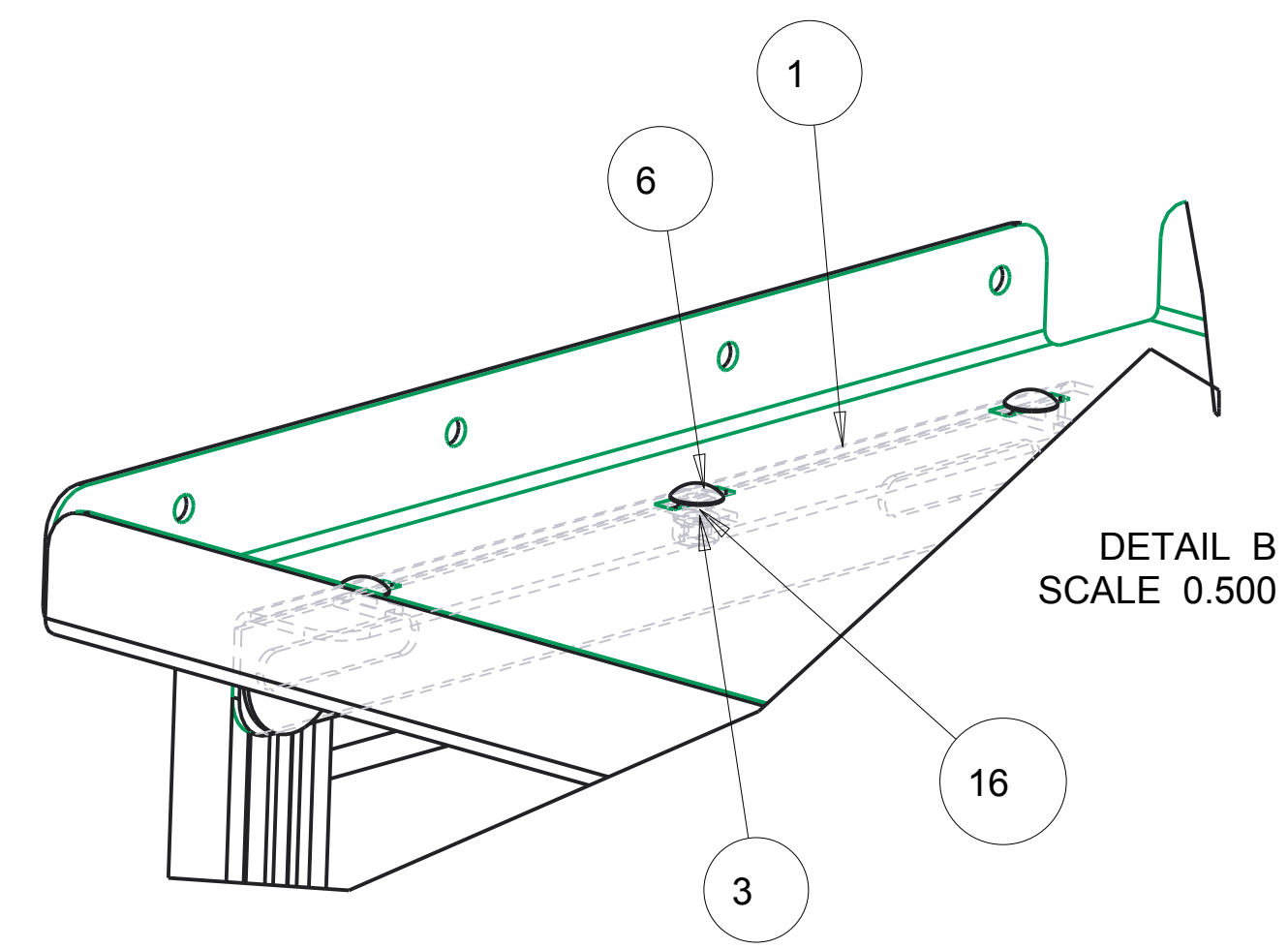
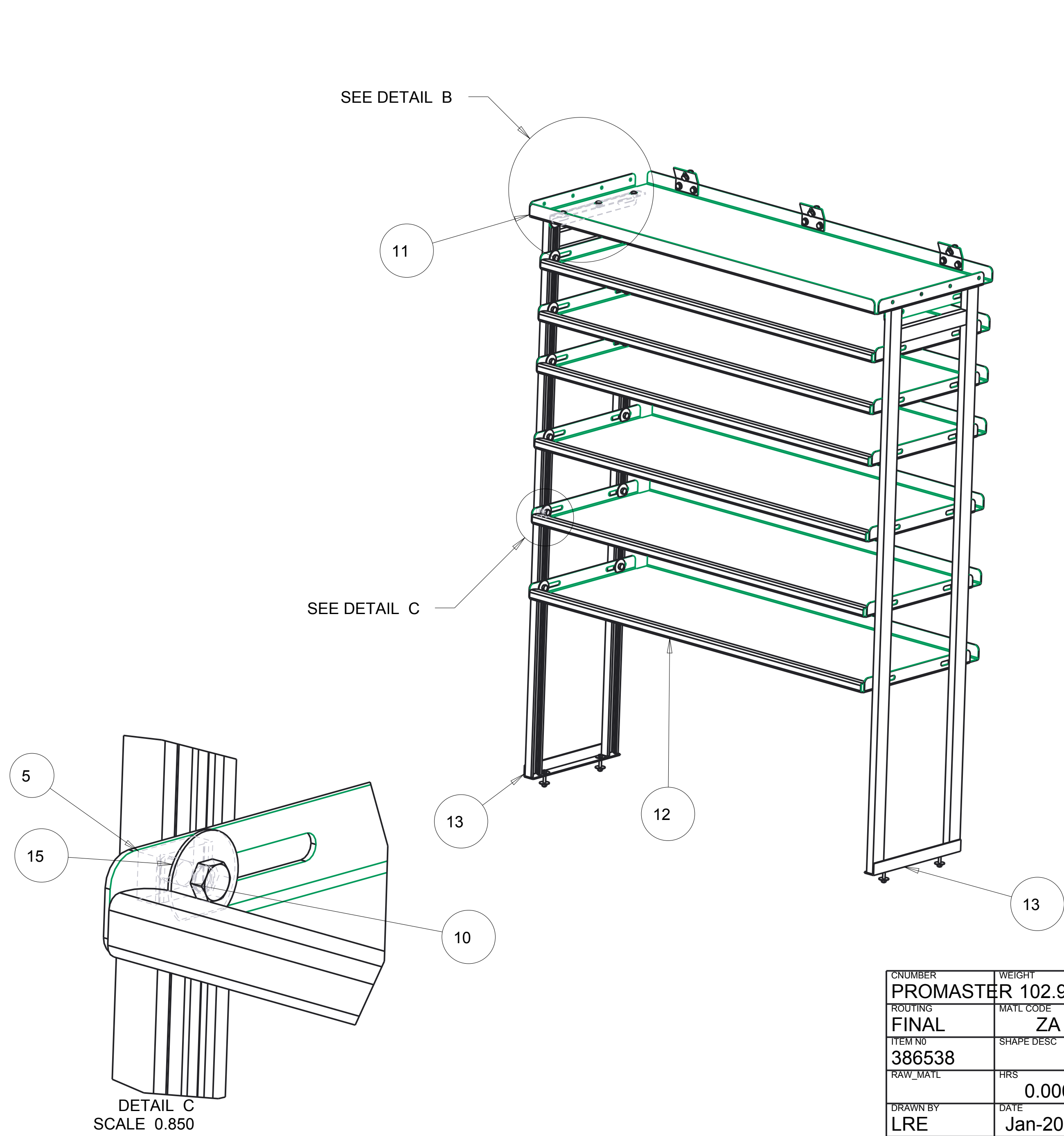

NUMBER	WEIGHT	TOLERANCE UNLESS OTHERWISE SPECIFIED
PROMASTER	102.96	
ROUTING	MATL CODE	
FINAL	ZA	.XX=+/- .060 .XXX=+/- .030
ITEM NO	SHAPE DESC	
386538		
RAW_MATL	HRS	
	0.000	
DRAWN BY	DATE	DESCRIPTION
LRE	Jan-20-17	SHELF ASM. -CURBSIDE PROMASTER 136" HIGH ROOF 46"
APPROVED BY	DATE	SCALE
		0.125
SUPERSEDES	SUPERSEDED BY	DWG NAME
		P16C0687 Sheet 3 of 4

VT Hackney *Hackney*
A company of VT Systems

Kidron

252-946-6521
vthackney.com hackney.com kidron.com vtvisioncomms.com **VisionComms**

ATTACHMENT DETAILS

* DRILL 3/8" HOLE THRU VAN WALL FLANGE AREA AFTER LAG SCREWS ARE INSTALLED

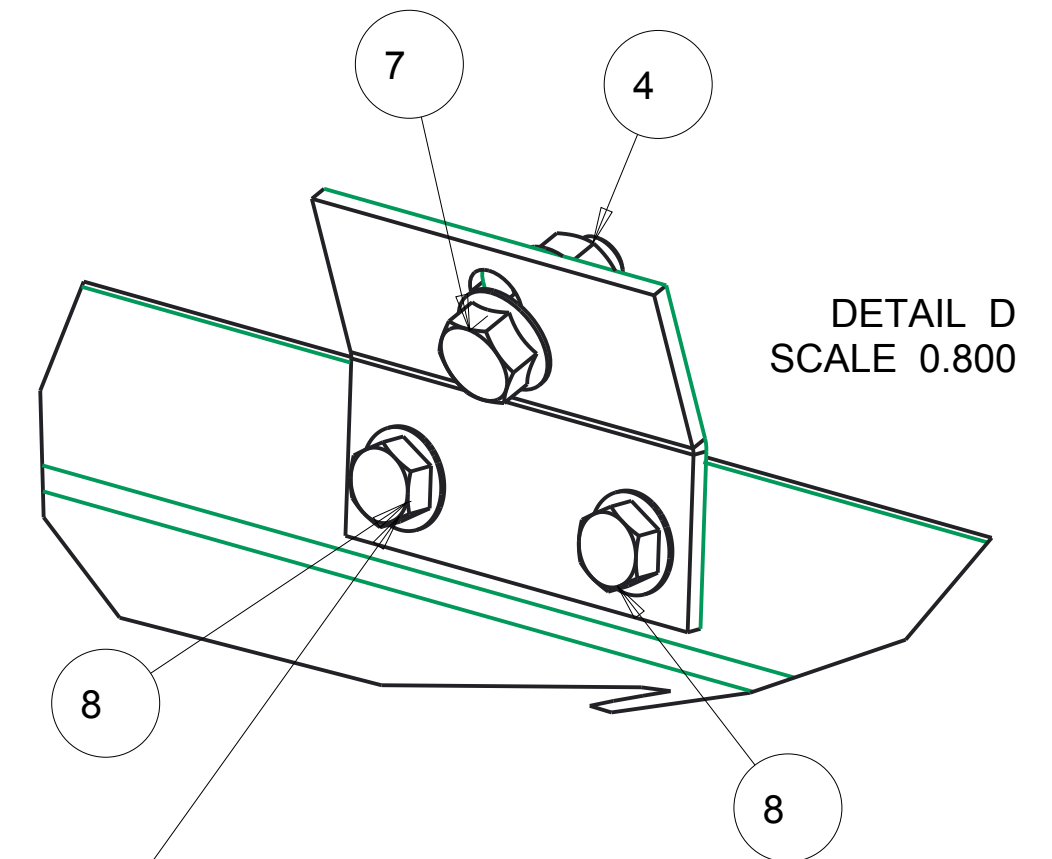
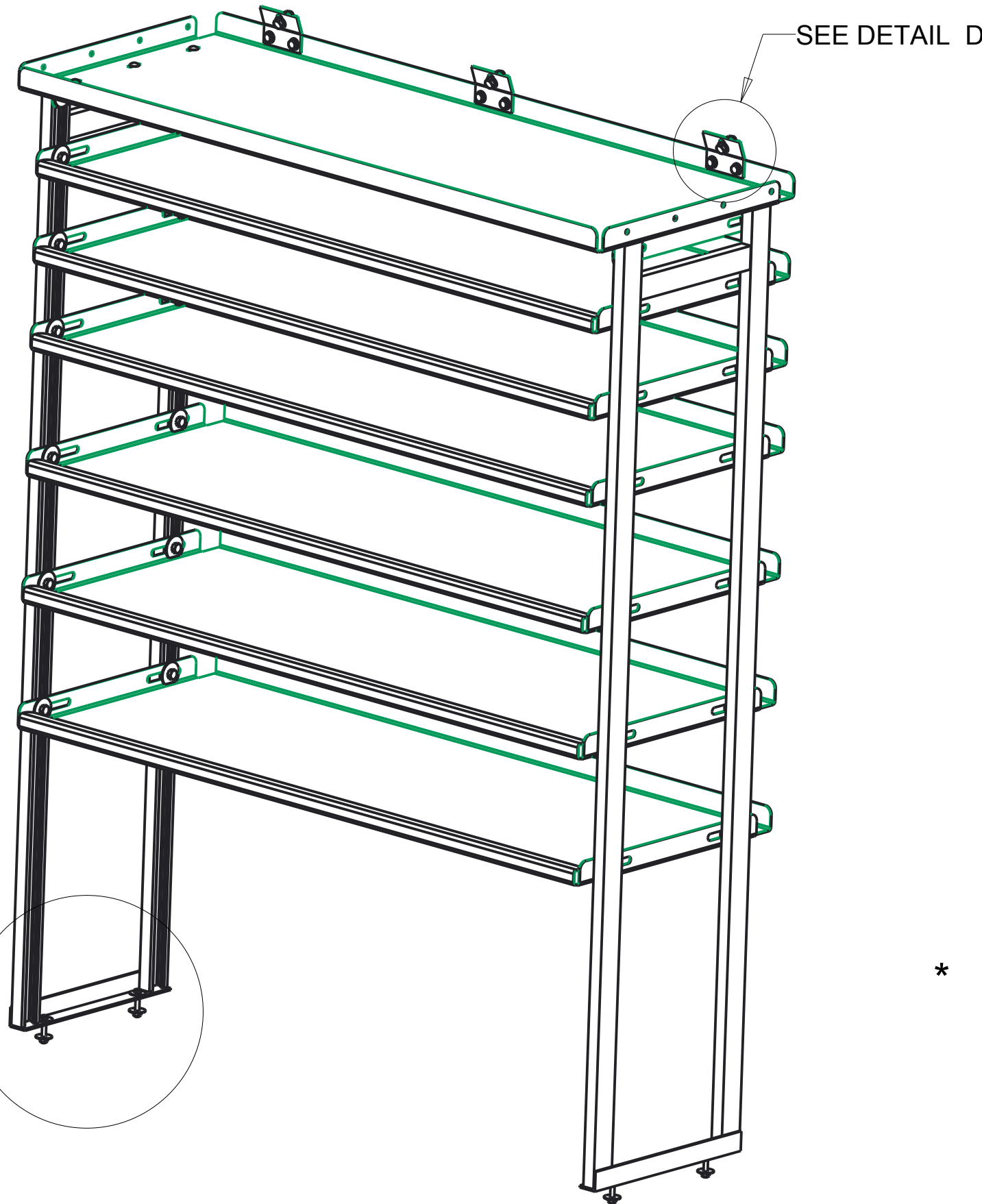
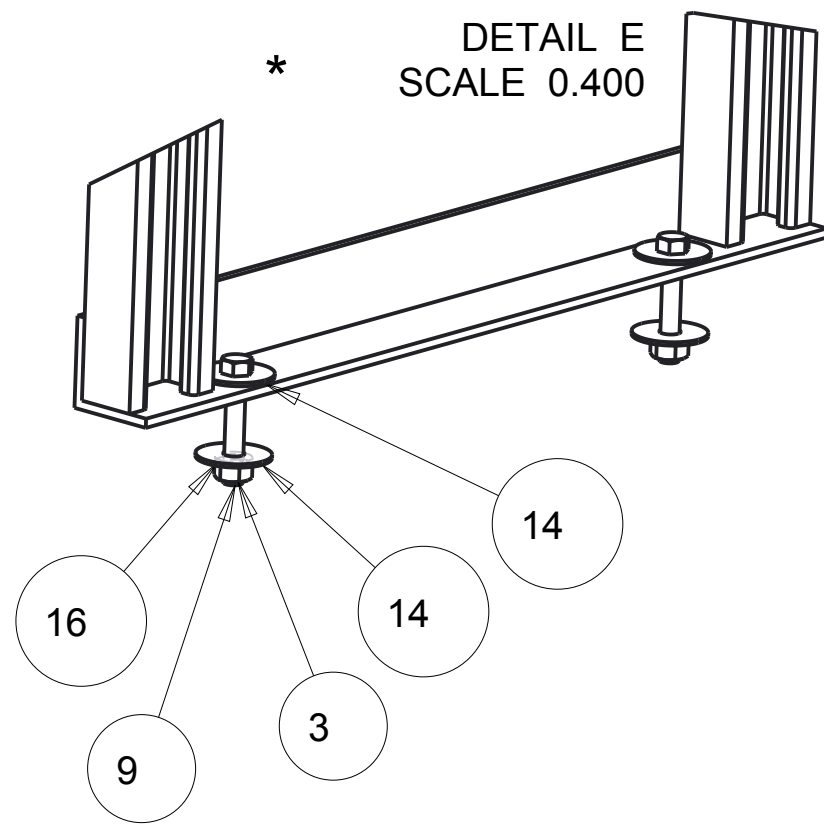

* MATCH HOLES IN ANGLE TO SHELF FLANGE, THEN DRILL 1/4" PILOT HOLES THRU VAN WALL, INSTALL 5-16" LAG SCREWS, DO NOT OVER TIGHTEN.

* NOTE: BEFORE DRILLING ANY HOLE THROUGH THE FLOOR OR WALL, VERIFY CLEARANCE ON BACKSIDE OF HOLE.

SEE DETAIL E

NUMBER	WEIGHT	TOLERANCE UNLESS OTHERWISE SPECIFIED	 A company of VT Systems
PROMASTER	102.96		
ROUTING	MATL CODE	.XX=+/- .060	252-946-6521 vtackney.com hackney.com kidron.com vtvisioncomms.com
FINAL	ZA	.XXX=+/- .030	
ITEM NO	SHAPE DESC		DESCRIPTION
386538			
RAW_MATL	HRS		SHELF ASM. -CURBSIDE PROMASTER 136" HIGH ROOF 46"
	0.000		
DRAWN BY	DATE	SCALE	DWG NAME
LRE	Jan-23-17	0.125	P16C0687 Sheet 4 of 4
APPROVED BY	DATE		
SUPERSEDES	SUPERSEDED BY		