

BBL NO.	ITEM DESCRIPTION	LENGTH	WIDTH	WEIGHT	MATL CODE	QTY REQD	ITEM NO.	MODEL NAME
1	ANGLE-.10X1.50X1.50X 13.25	13.250	2.810	0.334	BB2	3	385287	P15C0410
2	ANGLE-.10X1.50X1.50X 16.75	16.750	3.310	0.534	BB2	3	386528	386528
3	ANGLE-.12X1.25X1.25X 3.00	3.000	2.472	0.084	BB1	4	385505	385505
4	NUT-HEX .25 SST			0.007	E1	19	807862	807862
5	NUT-HEX 0.38 LK			0.018	E1	4	1485	1485
6	NUT-UNISTRUT W/O SPRING .38-16			0.086	C4	54	802807	802807
7	SCREW-CARRIAGE .25X .50			0.014	E0	17	826255	826255
8	SCREW-HEX 3/8-13X 1.00 FLANGE			0.059	E1	4	1490	1490
9	SCREW-HEX. LAG 3/8X 1.25 FLANGE	1.280		0.042	E0	8	811914	811914
10	SCREW-HEX.25X1.50 SST			0.027	E0	4	803172	803172
11	SCREW-HEX.38X .75 GR5	0.750		0.043	E0	54	802804	802804
12	SHELF-TOP 18"x94.50"	94.500	18.000	18.834	BB2	1	386531	P16C0535
13	SHELF-TRAY 18"x46"	46.000	18.000	9.633	BB2	9	385297	SHELF1_DS
14	SHELF-TRAY 18"x46" NOTCH	46.000	18.000	9.131	BB2	3	386516	SHELF2_DS_SP
15	UNISTRUT ASM-DOUBLE			9.296	ZA	1	385522	385522
16	UNISTRUT ASM-SINGLE			6.141	ZA	2	385500	385500
17	WASHER-FENDER .25 SST			0.009	E2	8	820746	820746
18	WASHER-FLAT .38 D-SHAPED			0.007	E2	58	816154	816154
19	WASHER-LOCK .25 SST			0.002	E2	19	803630	803630

NOTE:
1. FOR OPTIONAL SHELF LINER KIT, USE #386530

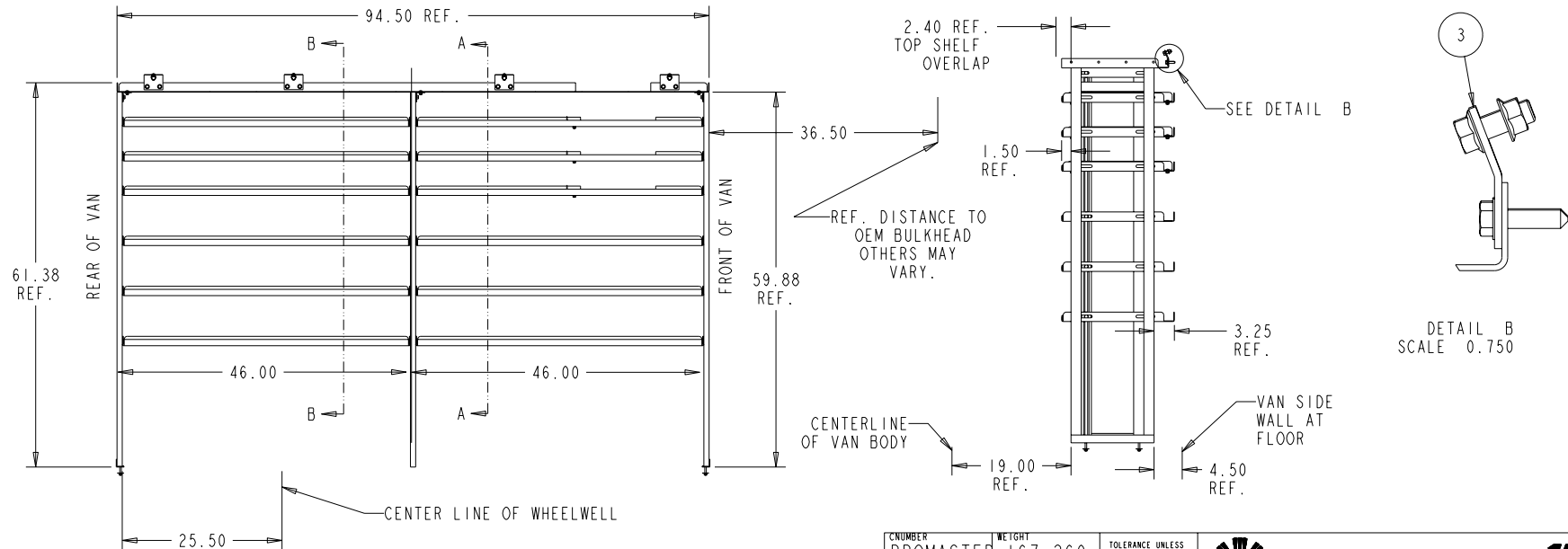

VIEWED FROM AISLE

THIS PRINT AND ALL RIGHTS TO THE DESIGN AND DETAIL THEREON ARE THE PROPERTY OF VT HACKNEY AND IS LOANED TO THE RECIPIENT SUBJECT TO RETURN UPON DEMAND. ITS CONTENTS ARE CONFIDENTIAL AND MUST NOT BE COPIED OR SUBMITTED TO OUTSIDE PARTIES FOR USE OR EXAMINATION. COPYRIGHT 2016 VT HACKNEY A COMPANY OF VT SYSTEMS

REV	REVISION DESCRIPTION	ECN	DATE	INITIALS

CNUMBER	WEIGHT	TOLERANCE UNLESS OTHERWISE SPECIFIED
PROMASTER	167.269	
ROUTING	MATL CODE	.XX=+/- .060 .XXX=+/- .030
FINAL	ZA	
ITEM NO	SHAPE DESC	
386529		
RAW_MATL	HRS	
	0.000	
DRAWN BY	DATE	
LRE	Dec-07-16	
APPROVED BY	DATE	
SUPERSEDES	SUPERSEDED BY	SCALE
		0.080

VT Hackney *Hackney*
A company of VT Systems **Kltron**

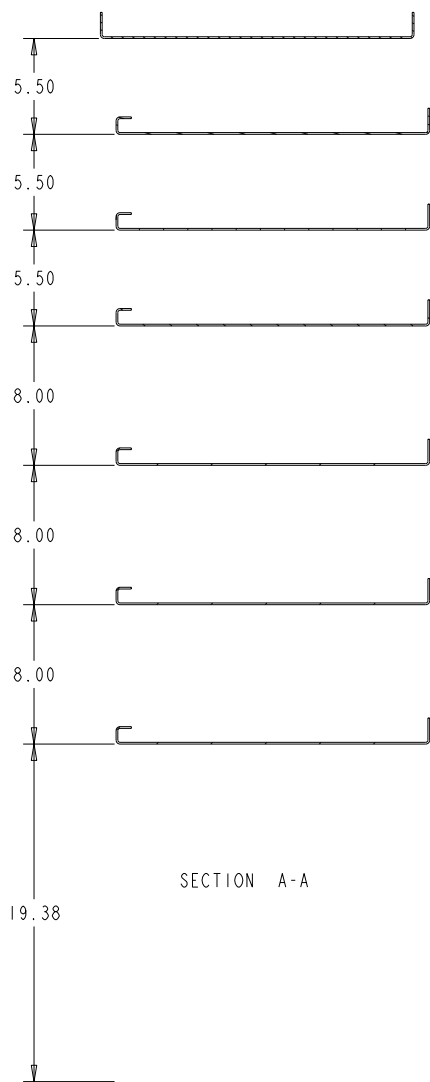

252-946-6521
vthackney.com hackney.com kltron.com vtvisioncomms.com **VisionComms**
DESCRIPTION SHELF ASM.- DRIVERSIDE PROMASTER 159"WB HIGH
ROOF 46-46

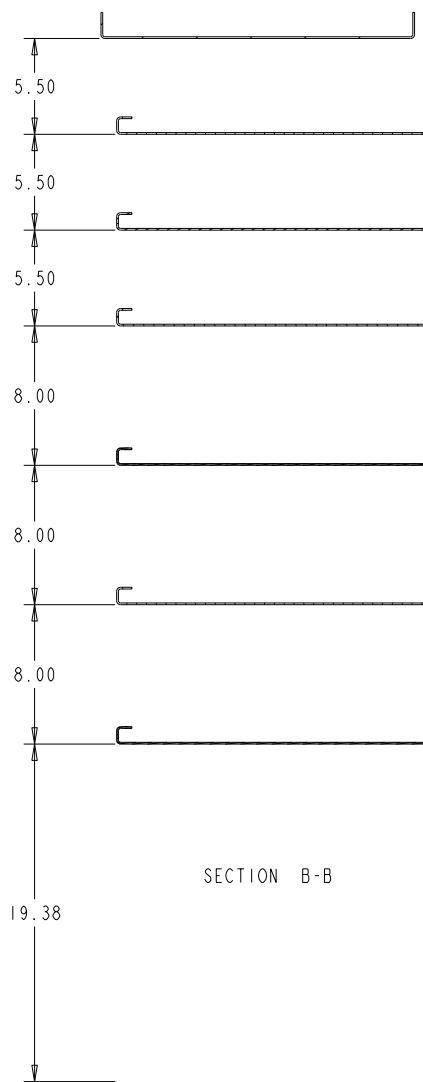

SECTION A-A



SECTION B-B

CNUMBER	WEIGHT	TOLERANCE UNLESS OTHERWISE SPECIFIED	 VT Hackney A company of VT Systems	
PROMASTER	167.269			
ROUTING	MATL CODE	.XX=+/- .060 .XXX=+/- .030	252-946-6521 vtackney.com hackney.com kidron.com vtvisioncomms.com VisionComms	
FINAL	ZA			
ITEM NO	SHAPE DESC		DESCRIPTION SHELF ASM.- DRIVERSIDE PROMASTER 159"WB HIGH ROOF 46-46	
386529				
RAW_MATL	HRS		DWG NAME P16C0534 Sheet 2 of 4	
	0.000			
DRAWN BY	DATE			
LRE	Dec-07-16			
APPROVED BY	DATE			
SUPERSEDES	SUPERSEDED BY	SCALE		
		0.200		

386529

386529

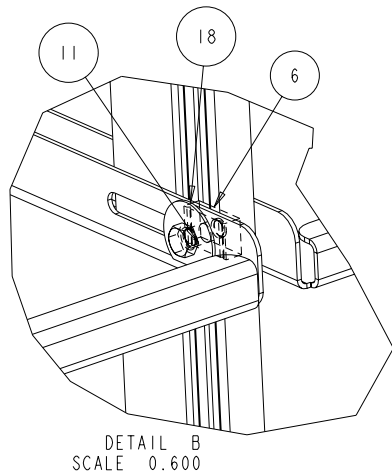
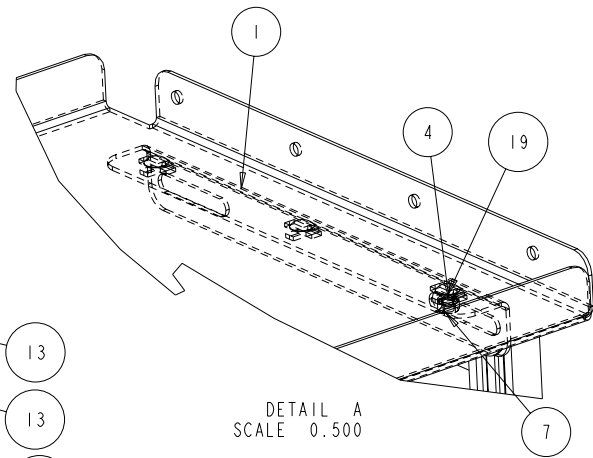
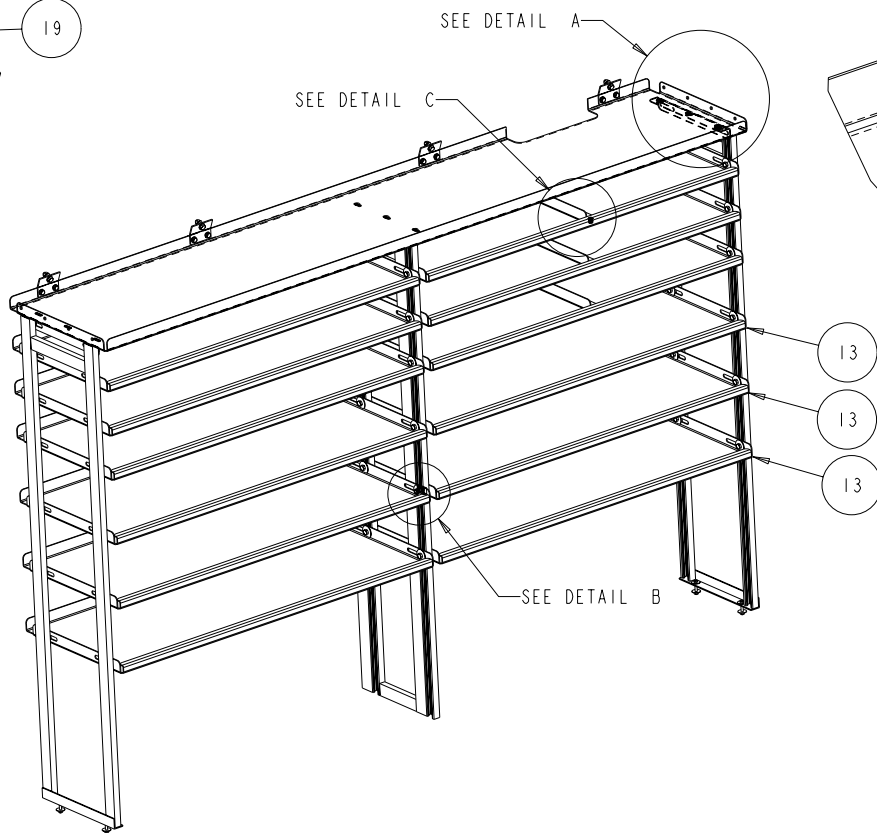
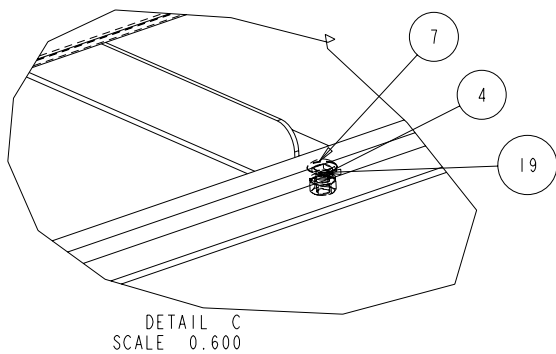

CNUMBER	WEIGHT	TOLERANCE UNLESS OTHERWISE SPECIFIED	
PROMASTER	167.269		
ROUTING	MATL CODE	.XX=+/- .060	
FINAL	ZA	XXX=+/- .030	
ITEM NO	SHAPE DESC		
386529			
RAW_MATL	HRS		
	0.000		
DRAWN BY	DATE	DESCRIPTION	
LRE	Dec-07-16	SHELF ASM.- DRIVERSIDE PROMASTER 159"WB HIGH ROOF 46-46	
APPROVED BY	DATE		
SUPERSEDES	SUPERSEDED BY	SCALE	DWG NAME
		0.100	

VT Hackney *Hackney*
A company of VT Systems **Kidron**

252-946-6521
vthackney.com hackney.com kidron.com vtvisioncomms.com **VisionComms**

ATTACHMENT DETAILS

* DRILL 3/8" HOLE THRU VAN WALL FLANGE AREA AFTER LAG SCREWS ARE INSTALLED

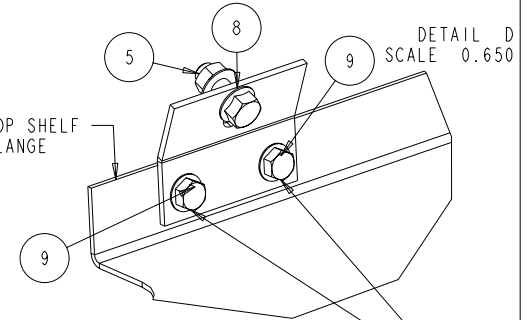
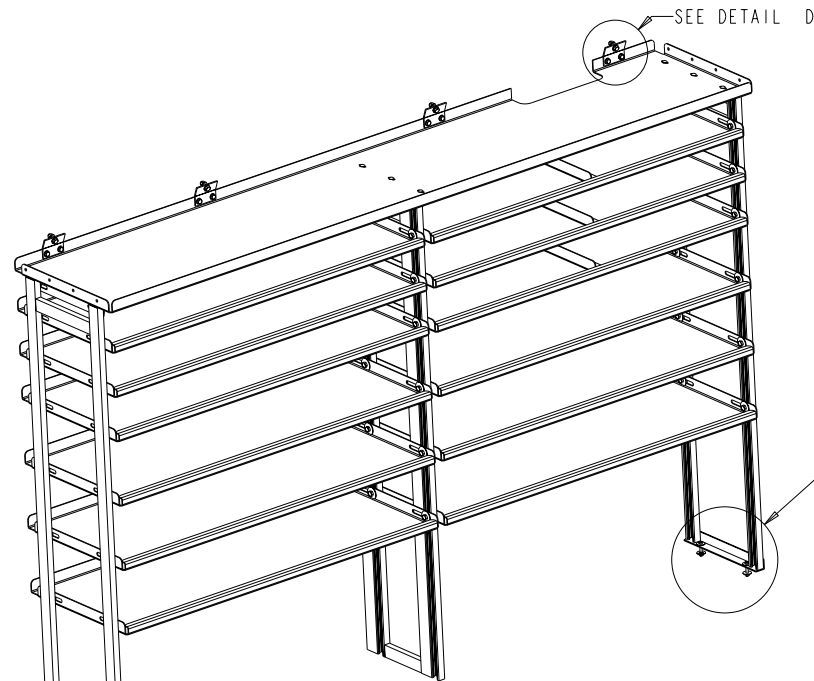

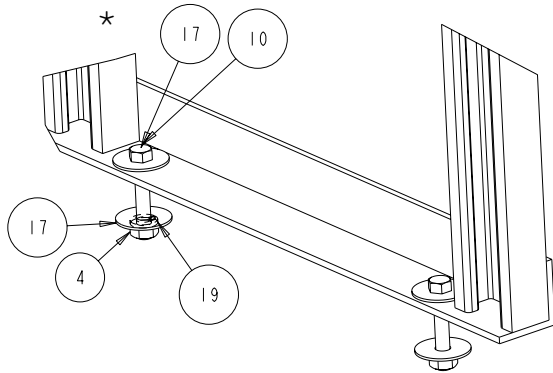

* MATCH HOLES IN ANGLE TO SHELF FLANGE, THEN DRILL 1/4" PILOT HOLES THRU VAN WALL, INSTALL 5/16" LAG SCREWS, DO NOT OVER TIGHTEN.



DETAIL E SCALE 0.650
BOLT THRU FLOOR

* **NOTE:**
BEFORE DRILLING ANY HOLE THROUGH THE FLOOR OR WALL, VERIFY CLERANCE ON BACKSIDE OF HOLE.

CNUMBER PROMASTER	WEIGHT 167.269	TOLERANCE UNLESS OTHERWISE SPECIFIED	 VT Hackney A company of VT Systems	
ROUTING FINAL	MATL CODE ZA	.XX=+/- .060 XXX=+/- .030		
ITEM NO 386529	SHAPE DESC		252-946-6521 vtackney.com hackney.com kidron.com vtvisioncomms.com	
RAW_MATL	HRS 0.000	DESCRIPTION		
DRAWN BY LRE	DATE Dec-07-16	SHELF ASM.- DRIVERSIDE PROMASTER 159"WB HIGH ROOF 46-46		
APPROVED BY	DATE	SCALE 0.100	DWG NAME	
SUPERSEDES	SUPERSEDED BY	P16C0534 Sheet 4 of 4		