

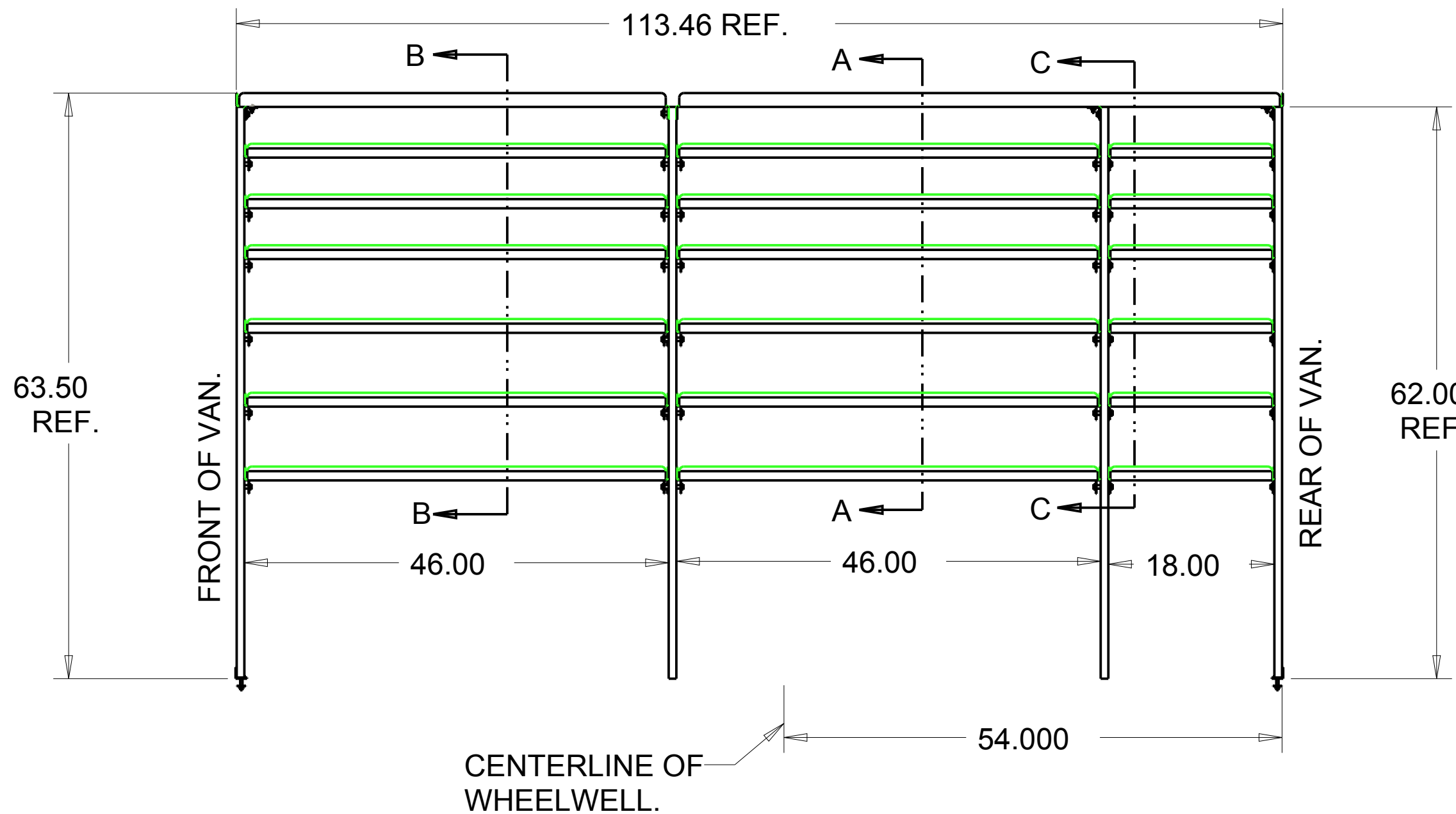

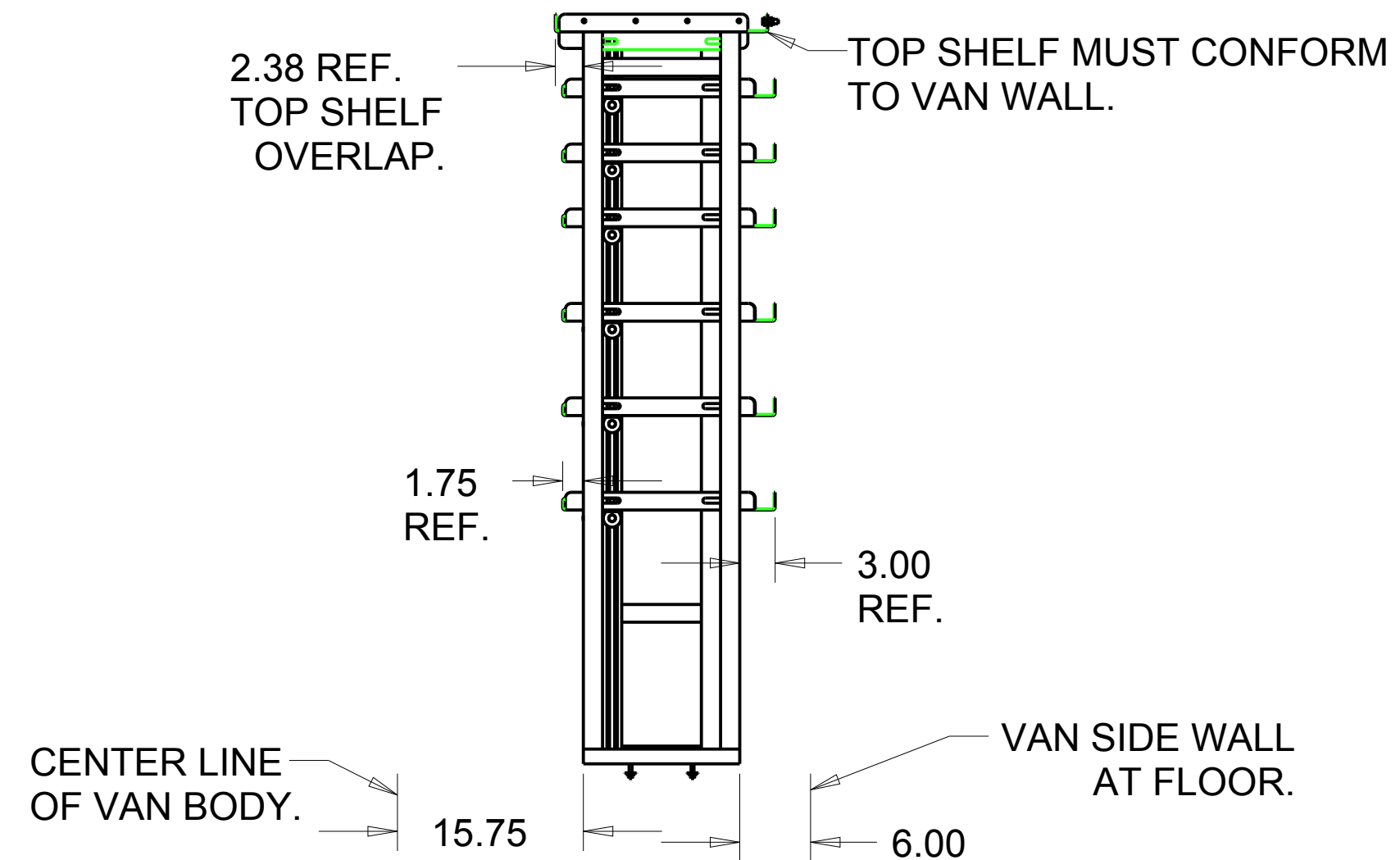

NOTE:
1. FOR OPTION SHELF
LINER KIT, USE # 386464

BBL NO.	ITEM DESCRIPTION	LENGTH	WIDTH	WEIGHT	MATL CODE	QTY REQD	ITEM NO.	MODEL NAME
1	ANGLE-.10X1.50X1.50X 13.25	13.250	2.810	0.334	BB2	3	385287	P15C0410
2	NUT-HEX .25 SST			0.007	E1	13	807862	807862
3	NUT-HEX .38 LK			0.018	E1	4	1485	1485
4	NUT-UNISTRUT W/O SPRING .38-16			0.086	C4	80	802807	802807
5	SCREW-CARRIAGE .25X .50			0.017	E0	9	826255	826255
6	SCREW-HEX 3/8-13X 1.00 FLANGE			0.059	E1	4	1490	1490
7	SCREW-HEX.25X1.50 SST			0.027	E0	4	803172	803172
8	SCREW-HEX.38X .75 GR5	0.750		0.043	E0	80	802804	802804
9	SHELF-TOP 18"x46.88"	46.875	18.000	9.730	BB2	1	386441	P16C0352
10	SHELF-TOP 18"x65.75"	65.750	18.000	13.502	BB2	1	386458	P16C0457
11	SHELF-TRAY 18"X18"	18.000	18.000	3.978	BB2	6	324703	SHELF3_CS
12	SHELF-TRAY 18"x46"	46.000	18.000	9.633	BB2	6	385297	SHELF1_CS
13	SHELF-TRAY 18"x46"	46.000	18.000	9.633	BB2	6	385297	SHELF2_CS
14	UNISTRUT ASM-DOUBLE			9.602	ZA	1	386420	386420
15	UNISTRUT ASM-DOUBLE 62" 12" WB			8.737	ZA	1	386437	386437
16	UNISTRUT ASM-SINGLE			6.302	ZA	2	386419	386419
17	WASHER-FENDER .25 SST			0.009	E2	8	820746	820746
18	WASHER-FLAT .38 D-SHAPED PLATED			0.028	E2	86	816154	816154
19	WASHER-LOCK .25 SST			0.002	E2	13	803630	803630



VIEW FROM AISLE



NUMBER	WEIGHT	TOLERANCE UNLESS OTHERWISE SPECIFIED	 A company of VT Systems
SPRINTER	208.09		
ROUTING	MATL CODE	.XX=+/- .060 .XXX=+/- .030	 252-946-6521 vthackney.com hackney.com kidron.com vtvisioncomms.com
FINAL	SHAPE DESC		
ITEM NO	HRS		 SHELF ASM. - C/S SPRINTER 170 EXT. WB HIGH ROOF 46-46-18
386452	0.000		
RAW_MATL	DATE		SCALE 0.075 DWG NAME P16C0401 Sheet 1 of 4
	26 AUG 16		
DRAWN BY	DATE		
LRE			
APPROVED BY	DATE		
SUPERSEDES	SUPERSEDED BY		

THIS PRINT AND ALL RIGHTS TO THE DESIGN AND DETAIL THEREON ARE THE PROPERTY OF VT HACKNEY AND IS LOANED TO THE RECIPIENT SUBJECT TO RETURN UPON DEMAND. ITS CONTENTS ARE CONFIDENTIAL AND MUST NOT BE COPIED OR SUBMITTED TO OUTSIDE PARTIES FOR USE OR EXAMINATION. COPYRIGHT 2016 VT HACKNEY A COMPANY OF VT SYSTEMS

REV	REVISION DESCRIPTION	ECN	DATE	INITIALS

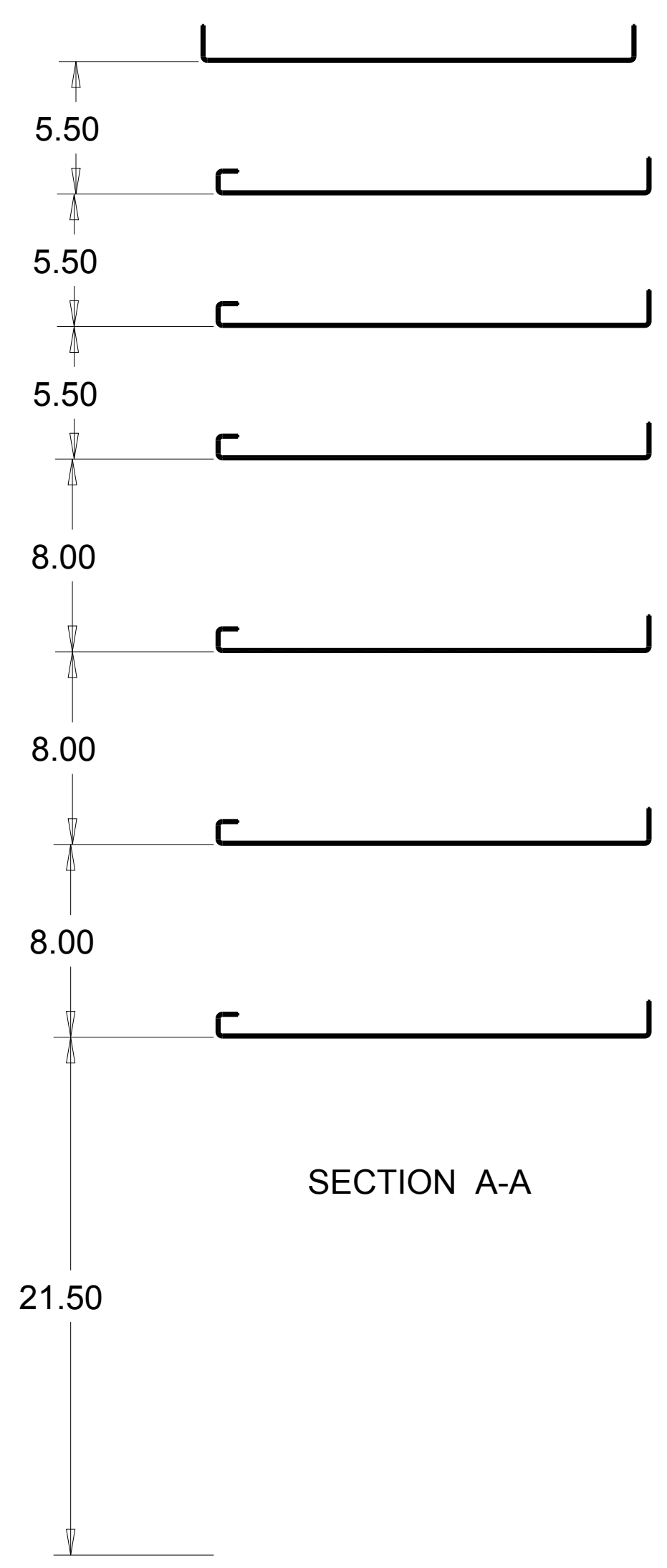

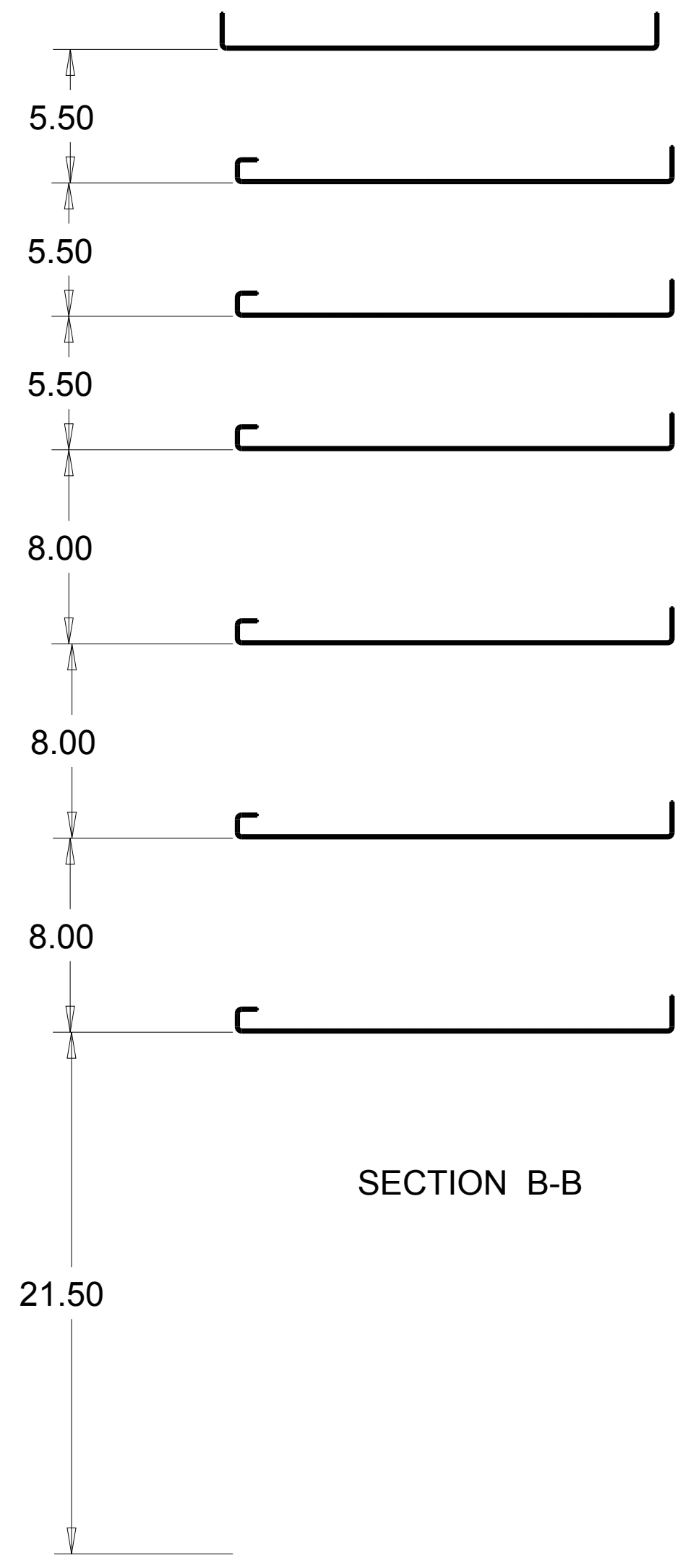

SECTION A-A

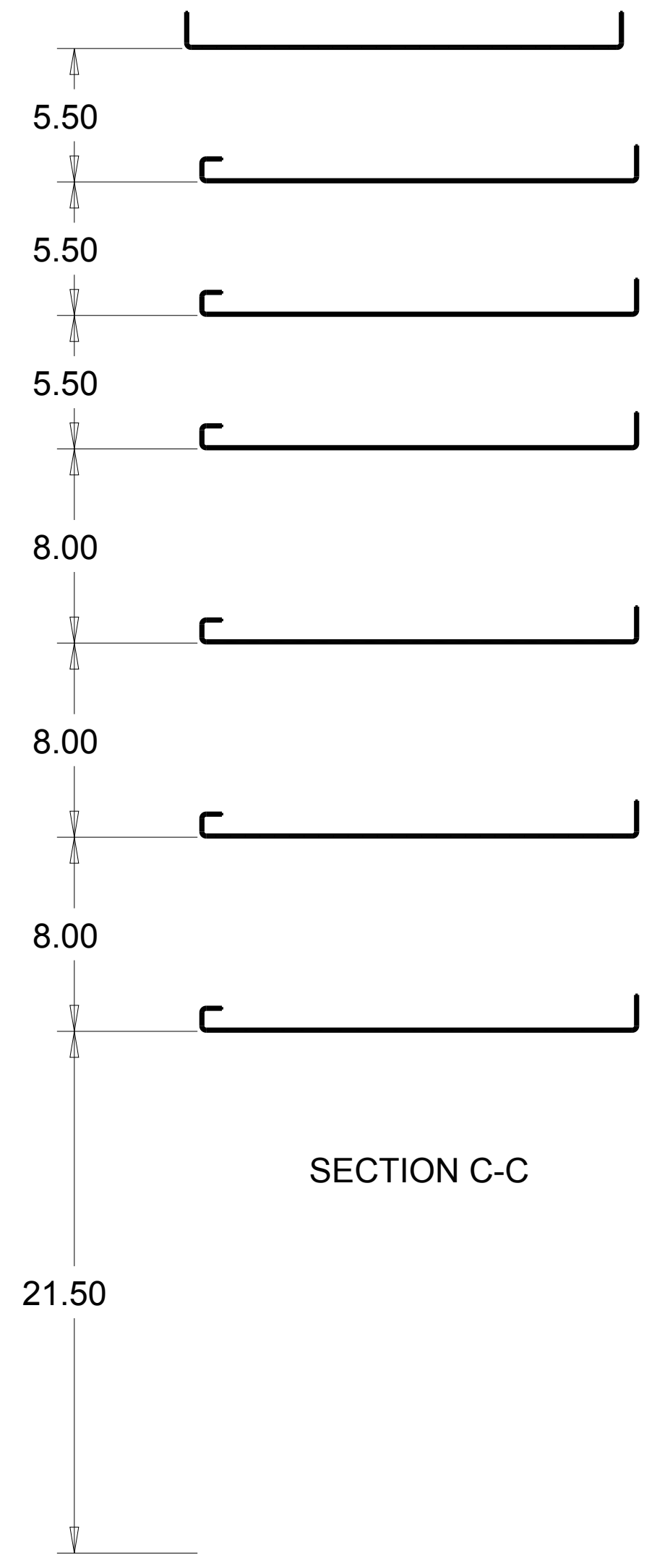

SECTION B-B



SECTION C-C

CNUMBER SPRINTER	WEIGHT 208.09	TOLERANCE UNLESS OTHERWISE SPECIFIED	 VT Hackney A company of VT Systems	
ROUTING FINAL	MATL CODE ZA	.XX=+/- .060 .XXX=+/- .030		
ITEM NO 386452	SHAPE DESC		252-946-6521 vtackney.com hackney.com kidron.com vtvisioncomms.com	
RAW_MATL	HRS 0.00	DESCRIPTION		
DRAWN BY LRE	DATE 29 AUG 16	SHELF ASM. - C/S SPRINTER 170 EXT. WB HIGH ROOF 46-46-18		
APPROVED BY	DATE			
SUPERSEDES	SUPERSEDED BY	SCALE 0.175	DWG NAME P16C0401 Sheet 2 of 4	

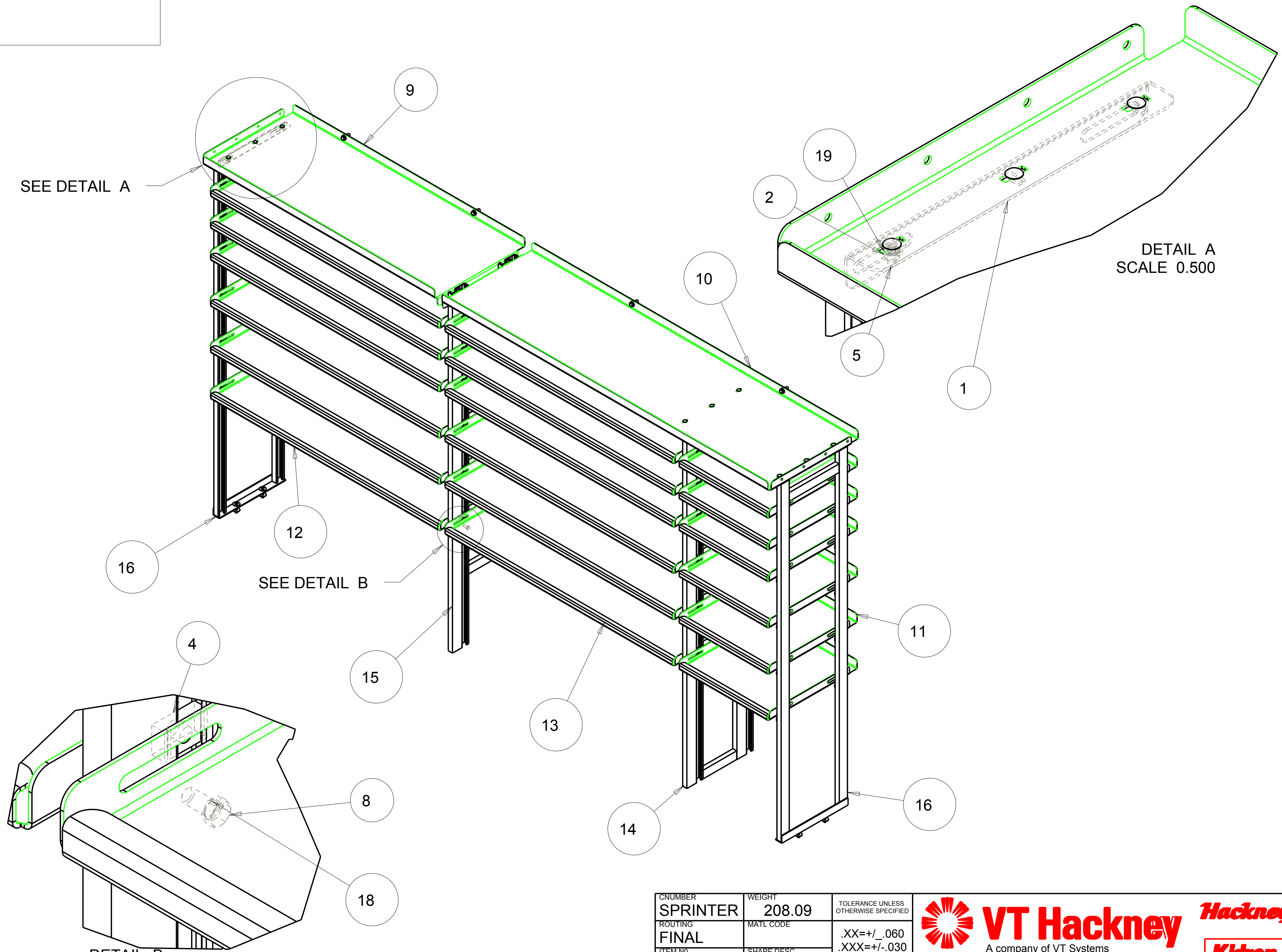

SEE DETAIL A

DETAIL A
SCALE 0.500

SEE DETAIL B

DETAIL B
SCALE 0.750

NUMBER	WEIGHT	TOLERANCE UNLESS OTHERWISE SPECIFIED
SPRINTER	208.09	
ROUTING	MATL CODE	.XX=+/- .060 .XXX=+/- .030
FINAL		
ITEM NO	SHAPE DESC	
386452		
RAW_MATL	HRS	
	0.000	
DRAWN BY	DATE	DESCRIPTION
LRE	29 AUG 16	SHELF ASM. - C/S SPRINTER 170 EXT. WB HIGH ROOF 46-46-18
APPROVED BY	DATE	
SUPERSEDES	SUPERSEDED BY	SCALE
		0.110
		DWG NAME
		P16C0401 Sheet 3 of 4

252-946-6521
 vtackney.com hackney.com kidron.com vtvisioncomms.com

ATTACHMENT DETAILS

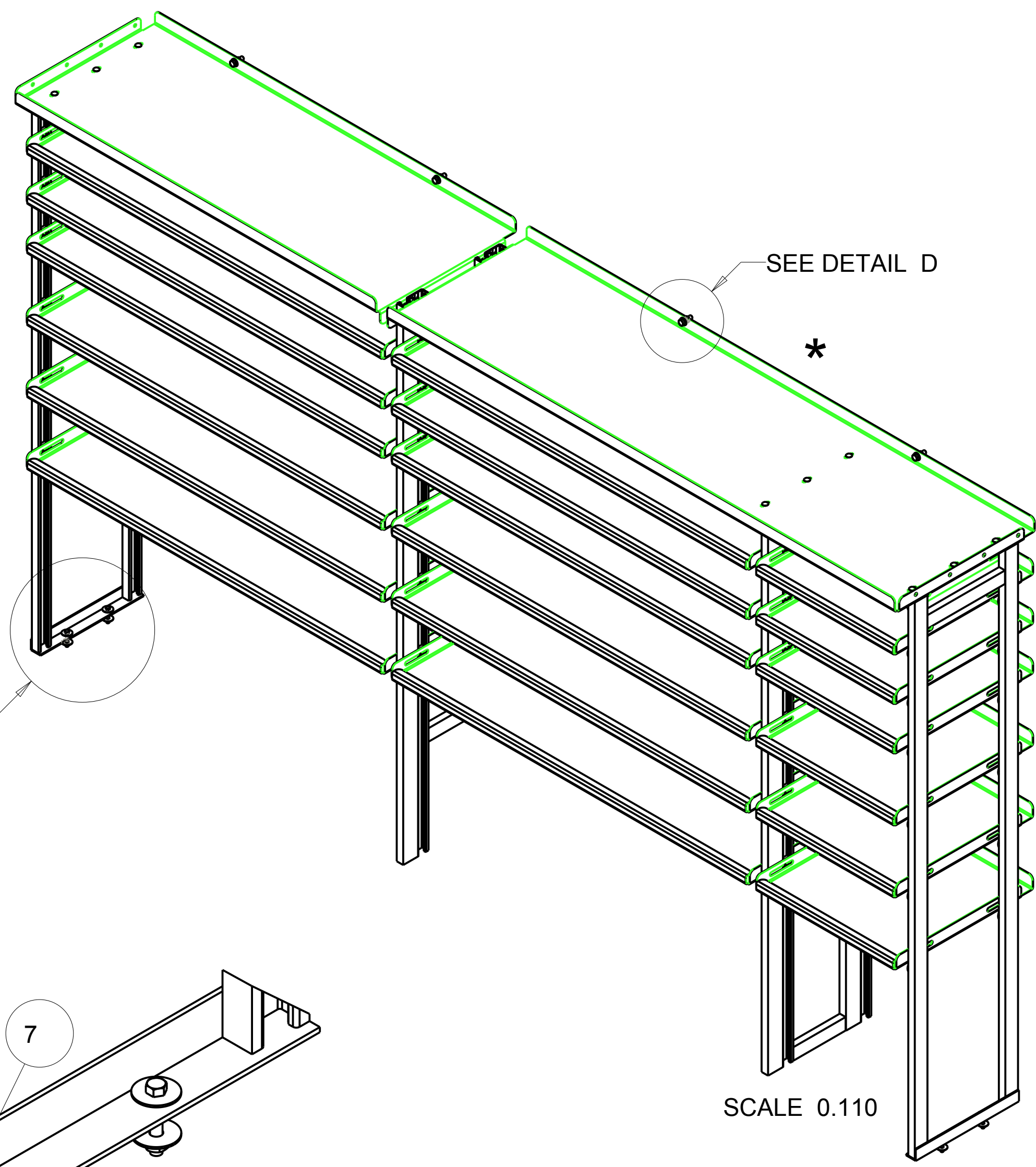

INSTALLATION NOTES;
 1.) INSTALLER RESPONSIBLE FOR SECURING SHELVING UNIT TO THE VAN USING SUPPLIED HARDWARE NOTED IN DETAILS C, AND D,
 2.) BEFORE DRILLING ANY HOLE THROUGH FLOOR OR WALL, VERIFY CLEARANCE ON BACKSIDE OF HOLE.

* DRILL 3/8" HOLE THRU VAN WALL FLANGE AREA

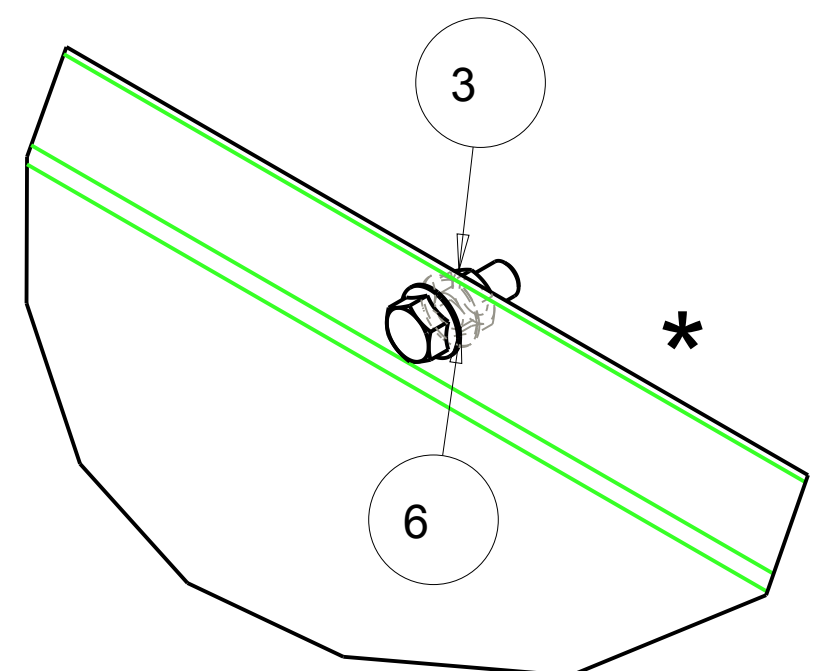

DETAIL D
SCALE 0.550

*NOTE:
BEFORE DRILLING ANY HOLE THROUGH THE FLOOR OR WALL, VERIFY CLEARANCE ON BACKSIDE OF HOLE:

SEE DETAIL C

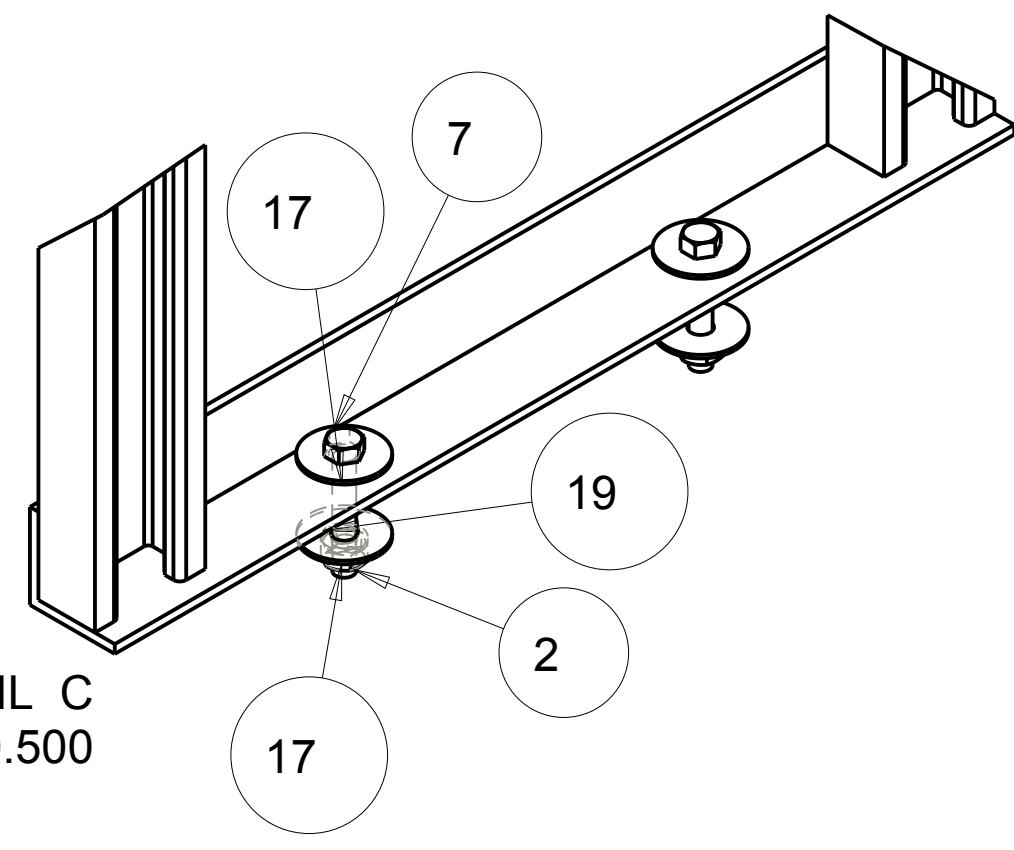

DETAIL C
SCALE 0.500

SCALE 0.110

NUMBER	WEIGHT	TOLERANCE UNLESS OTHERWISE SPECIFIED
SPRINTER	208.09	
ROUTING	MATL CODE	
FINAL	ZA	.XX=+/- .060 .XXX=+/- .030
ITEM NO	SHAPE DESC	
386452		
RAW_MATL	HRS	
	0.000	
DRAWN BY	DATE	DESCRIPTION
LRE	29 AUG 16	SHELF ASM. - C/S SPRINTER 170" EXT. WB HIGH ROOF 46-46-18
APPROVED BY	DATE	
SUPERSEDES	SUPERSEDED BY	SCALE
		0.075

VT Hackney *Hackney*
 A company of VT Systems

252-946-6521
 vtackney.com hackney.com kidron.com vtvisioncomms.com **VisionComms**

Kidron