

NOTE:
1. FOR OPTION SHELF LINER KIT, USE #386443

BBL NO.	ITEM DESCRIPTION	LENGTH	WIDTH	WEIGHT	MATL CODE	QTY REQD	ITEM NO.	MODEL NAME
1	ANGLE-.10X1.50X1.50X 13.25	13.250	2.810	0.334	BB2	2	385287	P15C0410
2	NUT-HEX .25 SST			0.007	E1	10	807862	807862
3	NUT-HEX .38 LK			0.018	E1	4	1485	1485
4	NUT-UNISTRUT W/O SPRING .38-16			0.086	C4	56	802807	802807
5	SCREW-CARRIAGE .25X .50			0.014	E0	6	826255	826255
6	SCREW-HEX 3/8-13X 1.00 FLANGE			0.059	E1	4	1490	1490
7	SCREW-HEX.25X1.50 SST			0.027	E0	4	803172	803172
8	SCREW-HEX.38X .75 GR5	0.750		0.043	E0	56	802804	802804
9	SHELF-TOP 18"x46.88"	46.875	18.000	9.730	BB2	1	386440	P16C0353
10	SHELF-TOP 18"x46.88"	46.875	18.000	9.730	BB2	1	386441	P16C0352
11	SHELF-TRAY 18"x46"	46.000	18.000	9.633	BB2	6	385297	SHELF1_CS
12	SHELF-TRAY 18"x46"	46.000	18.000	9.633	BB2	6	385297	SHELF2_CS
13	UNISTRUT ASM-DOUBLE 62" 12" WB			8.737	ZA	1	386437	386437
14	UNISTRUT ASM-SINGLE			6.302	ZA	2	386419	386419
15	WASHER-FENDER .25 SST			0.009	E2	8	820746	820746
16	WASHER-FLAT .38 D-SHAPED			0.007	E2	56	816154	816154
17	WASHER-LOCK .25 SST			0.002	E2	10	803630	803630

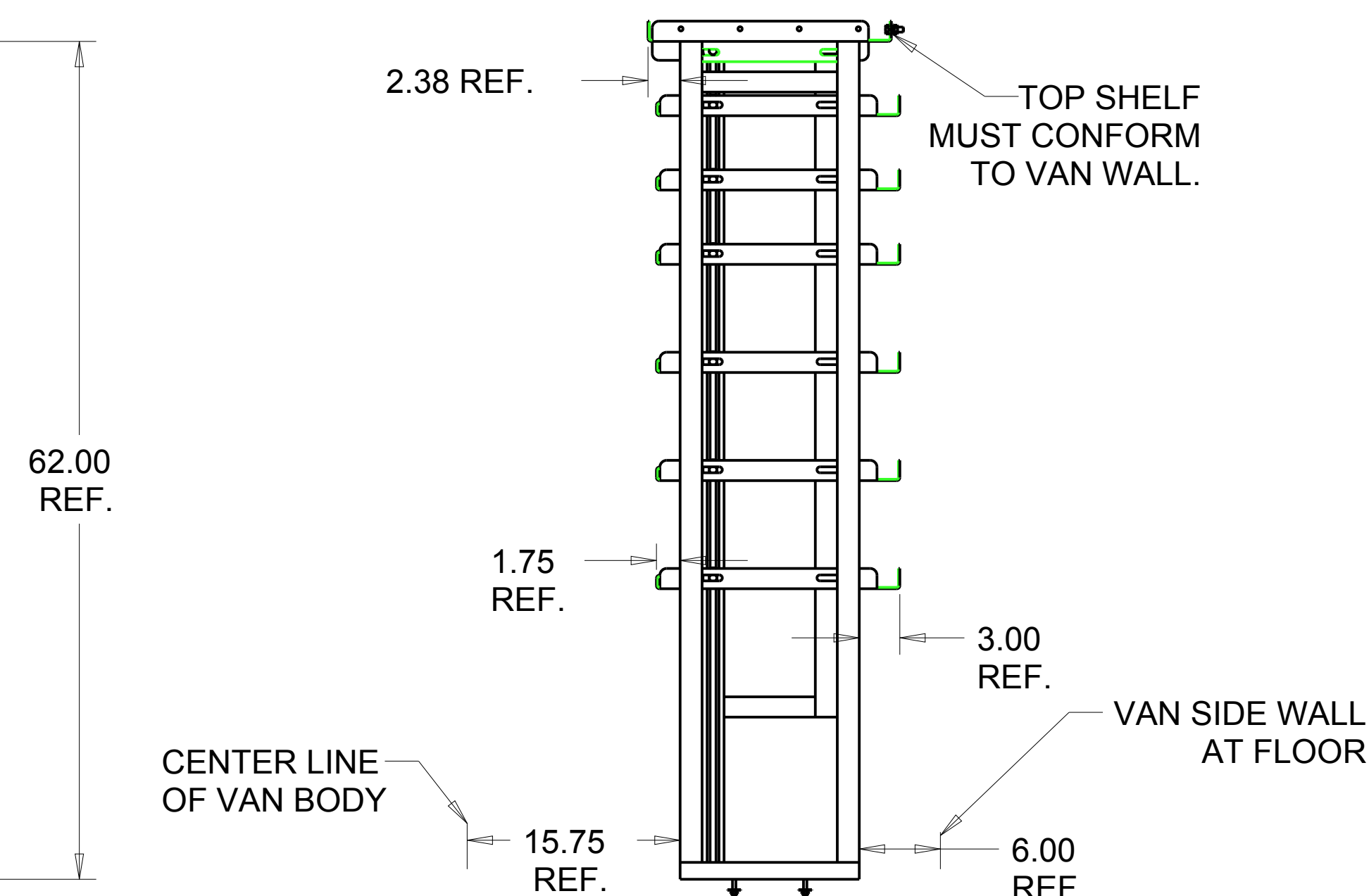
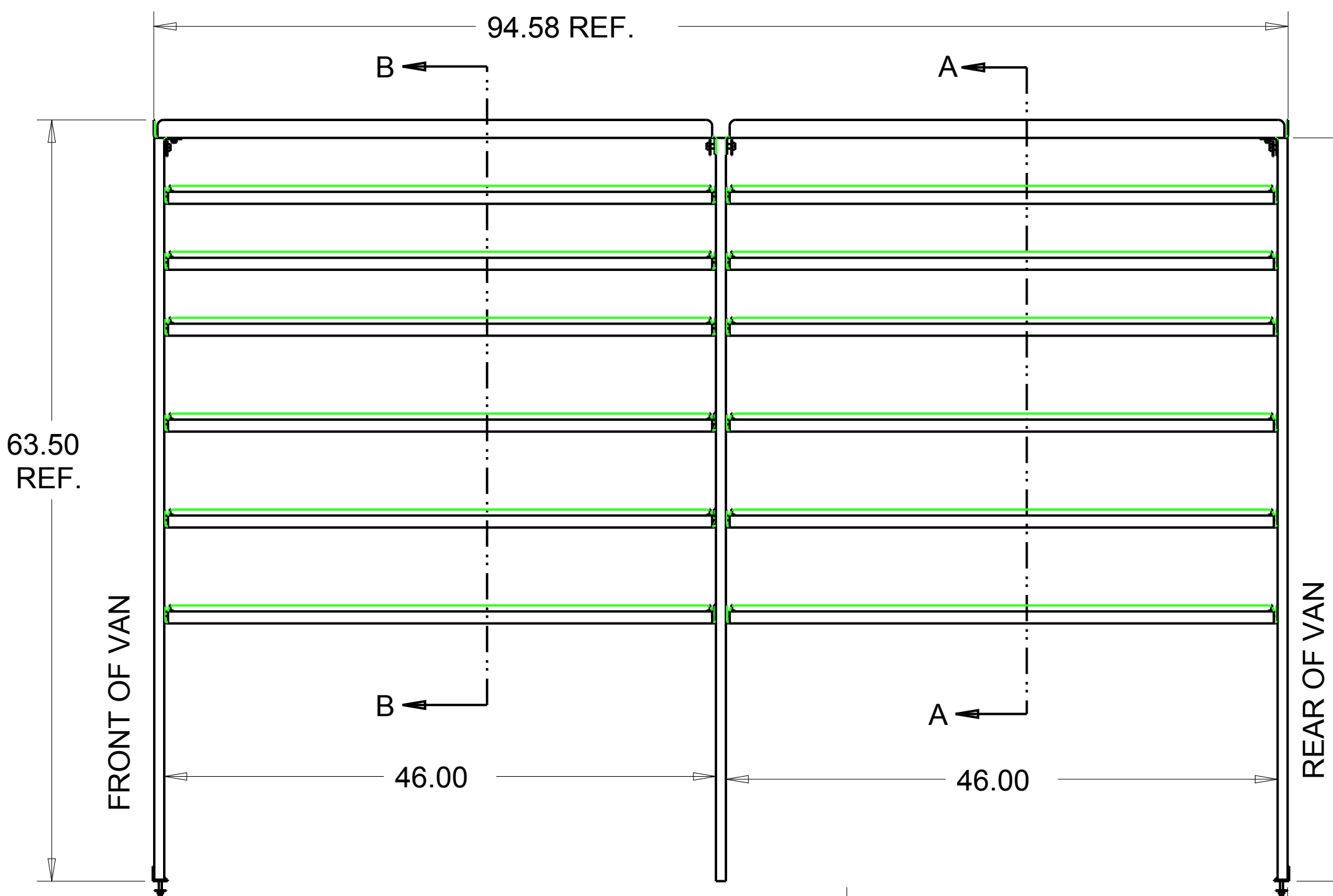

NUMBER	WEIGHT	TOLERANCE UNLESS OTHERWISE SPECIFIED
SPRINTER	166.515	.XX=+/- .060 .XXX=+/- .030
ROUTING	MATL CODE	
ITEM NO	SHAPE DESC	
386438		
RAW_MATL	HRS	
DRAWN BY	DATE	DESCRIPTION
LRE	05 AUG 16	SHELF ASM. CURBSIDE SPRINTER 170"WB HIGH ROOF 46-46 STD.
APPROVED BY	DATE	SCALE
		0.100
SUPERSEDES	SUPERSEDED BY	DWG NAME
		P16C0317 Sheet 1 of 4

VT Hackney
A company of VT Systems

Kidron

252-946-6521
vthackney.com hackney.com kidron.com vtvisioncomms.com

VisionComms

THIS PRINT AND ALL RIGHTS TO THE DESIGN AND DETAIL THEREON ARE THE PROPERTY OF VT HACKNEY AND IS LOANED TO THE RECIPIENT SUBJECT TO RETURN UPON DEMAND. ITS CONTENTS ARE CONFIDENTIAL AND MUST NOT BE COPIED OR SUBMITTED TO OUTSIDE PARTIES FOR USE OR EXAMINATION. COPYRIGHT 2016 VT HACKNEY A COMPANY OF VT SYSTEMS



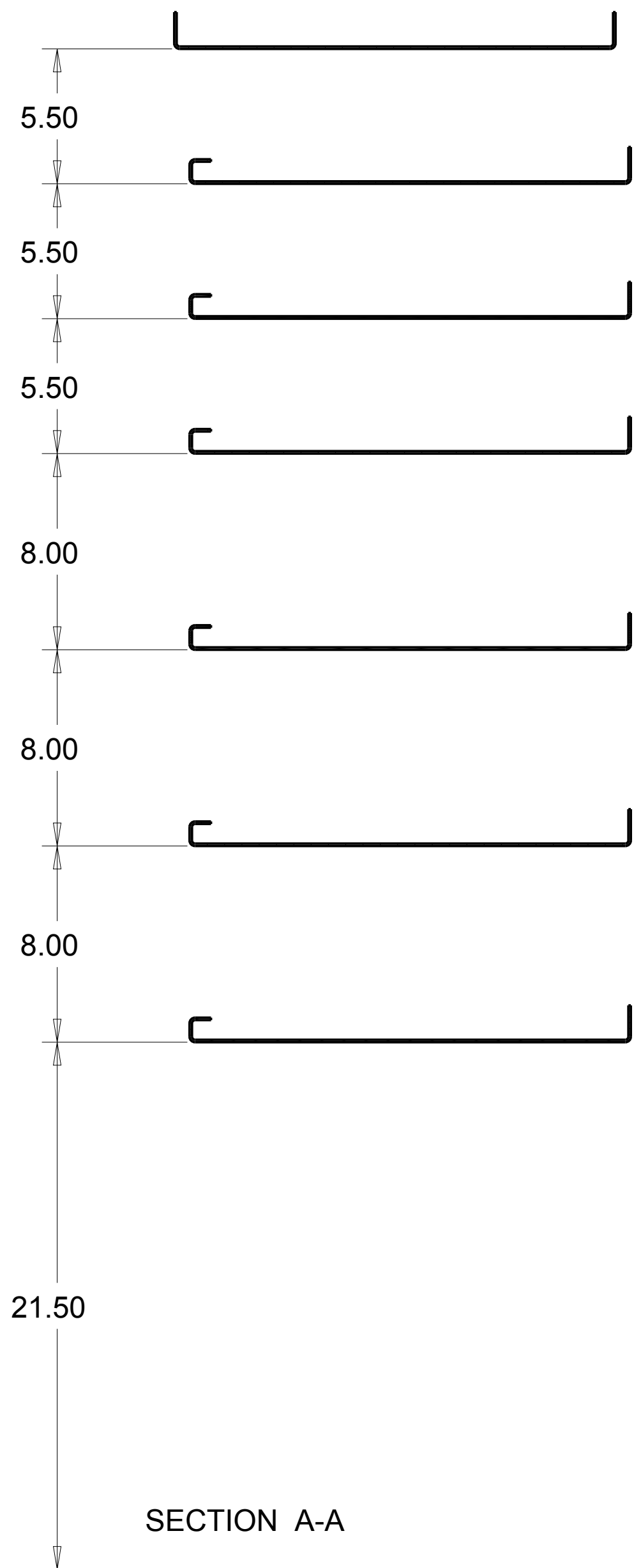

REV	REVISION DESCRIPTION	ECN	DATE	INITIALS

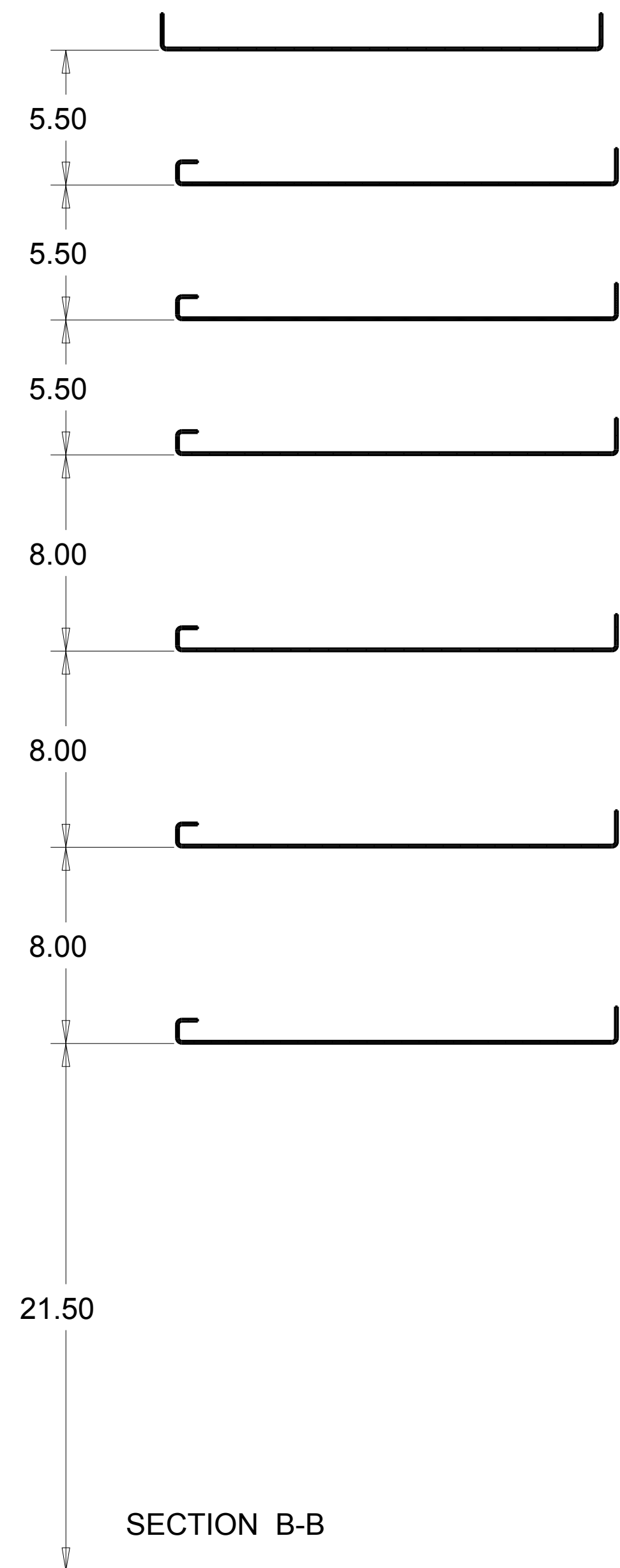

SECTION A-A



SECTION B-B

CNUMBER SPRINTER	WEIGHT 166.515	TOLERANCE UNLESS OTHERWISE SPECIFIED	 VT Hackney A company of VT Systems 252-946-6521 vtackney.com hackney.com kidron.com vtvisioncomms.com	  
ROUTING	MATL CODE	.XX=+/- .060 .XXX=+/- .030		
ITEM NO 386438	SHAPE DESC			
RAW_MATL	HRS	DESCRIPTION	SHELF ASM. CURBSIDE SPRINTER 170"WB HIGH ROOF 46-46 STD.	
DRAWN BY LRE	DATE 05 AUG 16		SCALE 0.200	DWG NAME P16C0317 Sheet 2 of 4
APPROVED BY	DATE			
SUPERSEDES	SUPERSEDED BY			

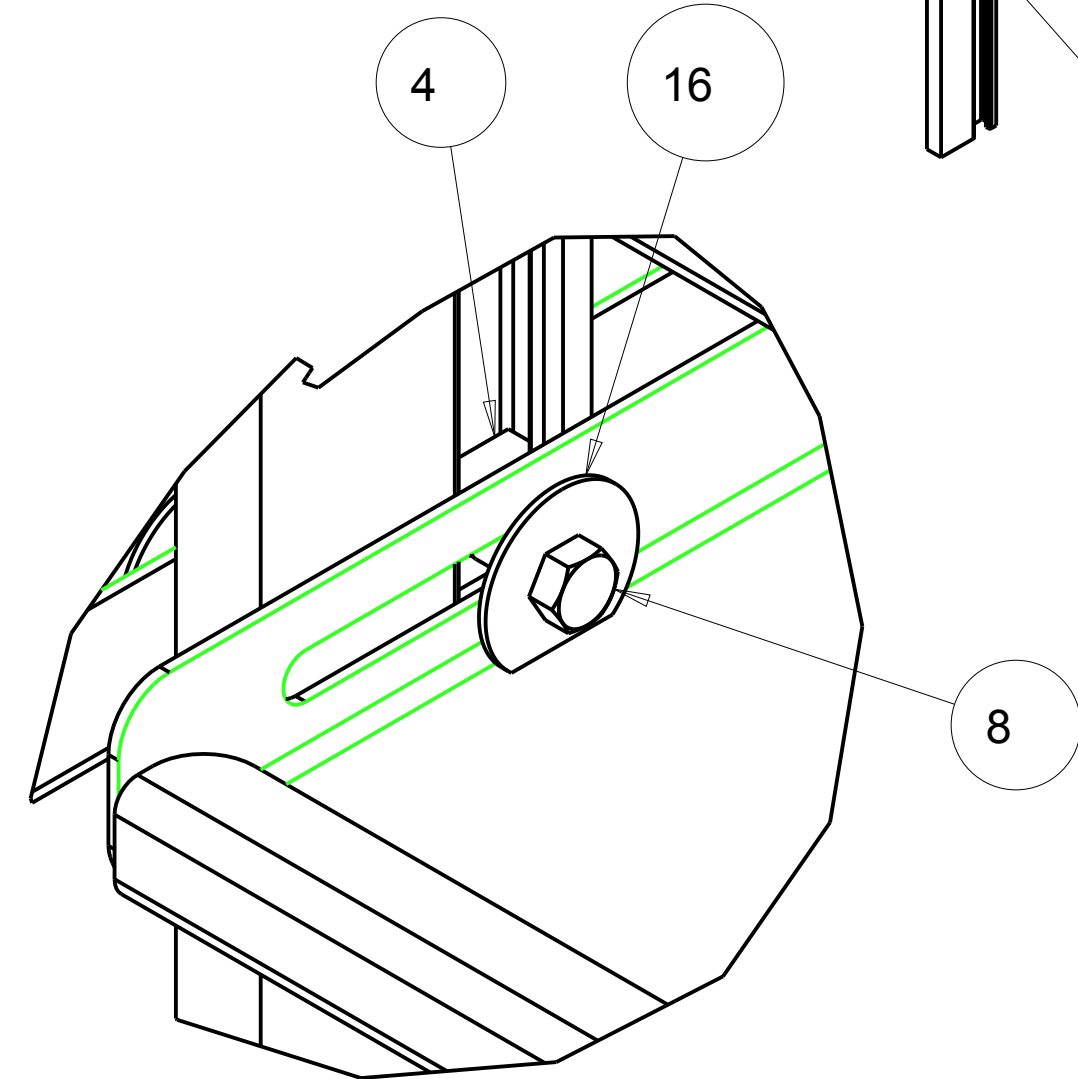
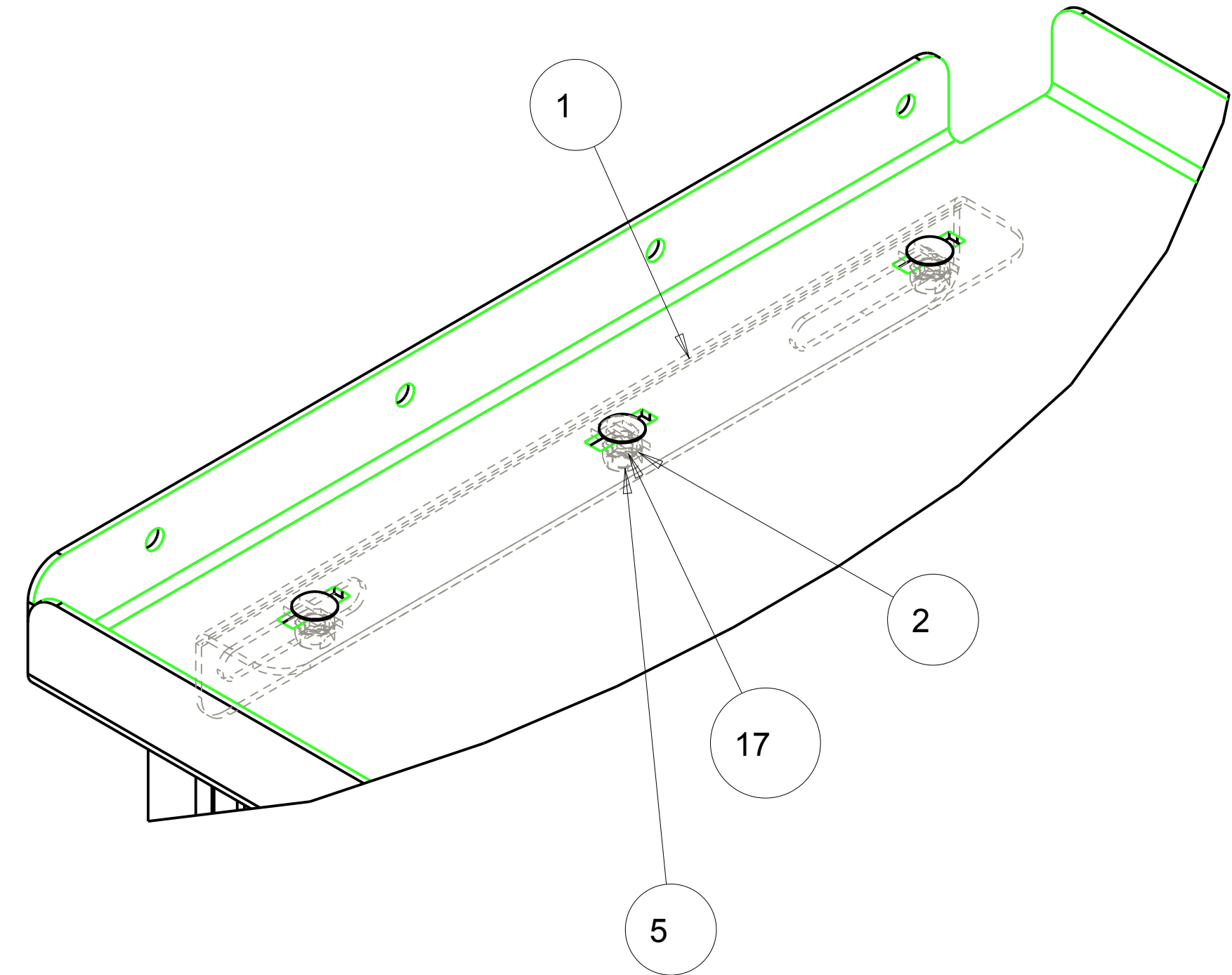
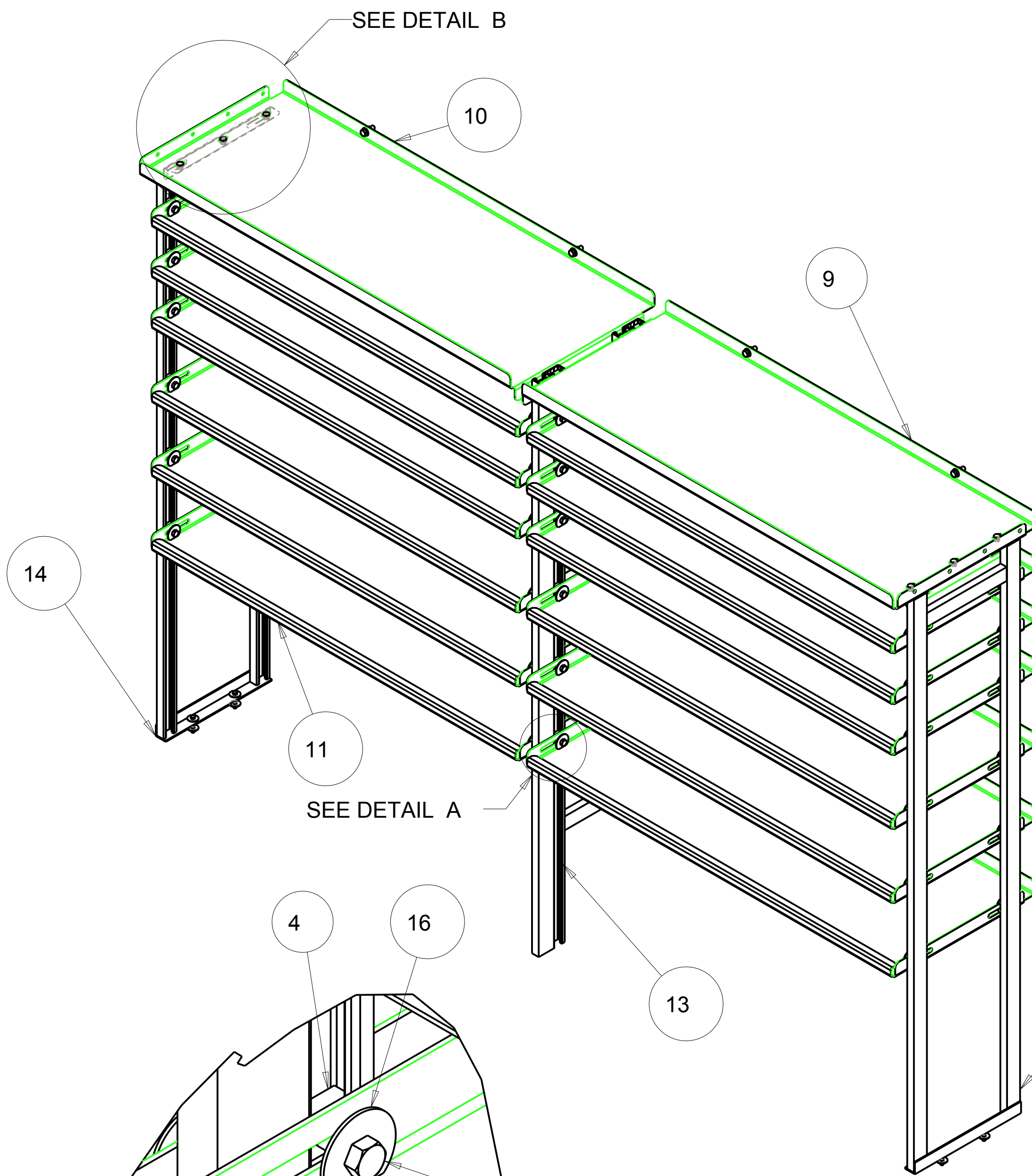

DETAIL A
SCALE 0.750

NUMBER SPRINTER	WEIGHT 166.51	TOLERANCE UNLESS OTHERWISE SPECIFIED	 A company of VT Systems
ROUTING	MATL CODE	.XX=+/- .060 .XXX=+/- .030	
ITEM NO 386438	SHAPE DESC		252-946-6521 vtackney.com hackney.com kidron.com vtvisioncomms.com
RAW_MATL	HRS		
DRAWN BY LRE	DATE 05 AUG 16	DESCRIPTION SHELF ASM. CURBSIDE SPRINTER 170"WB HIGH ROOF 46-46 STD.	
APPROVED BY	DATE	SCALE 0.125	DWG NAME P16C0317 Sheet 3 of 4
SUPERSEDES	SUPERSEDED BY		

Hackney

Kidron

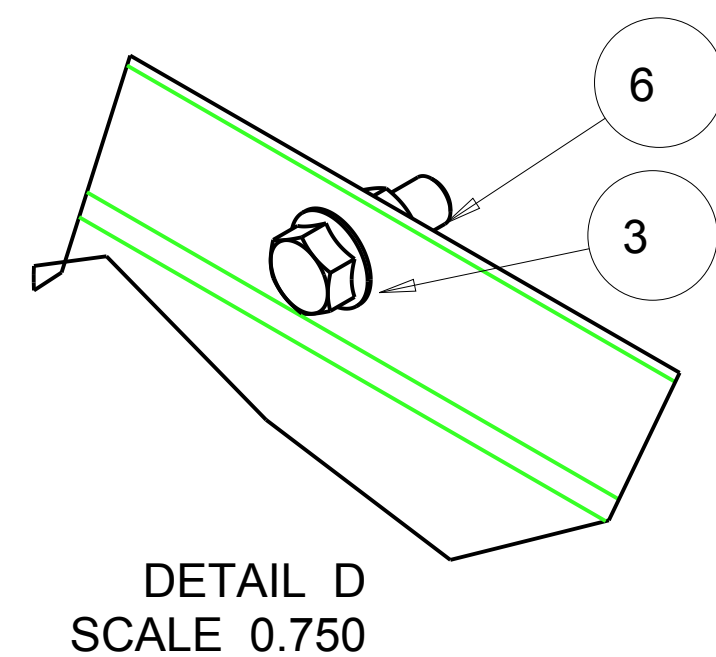
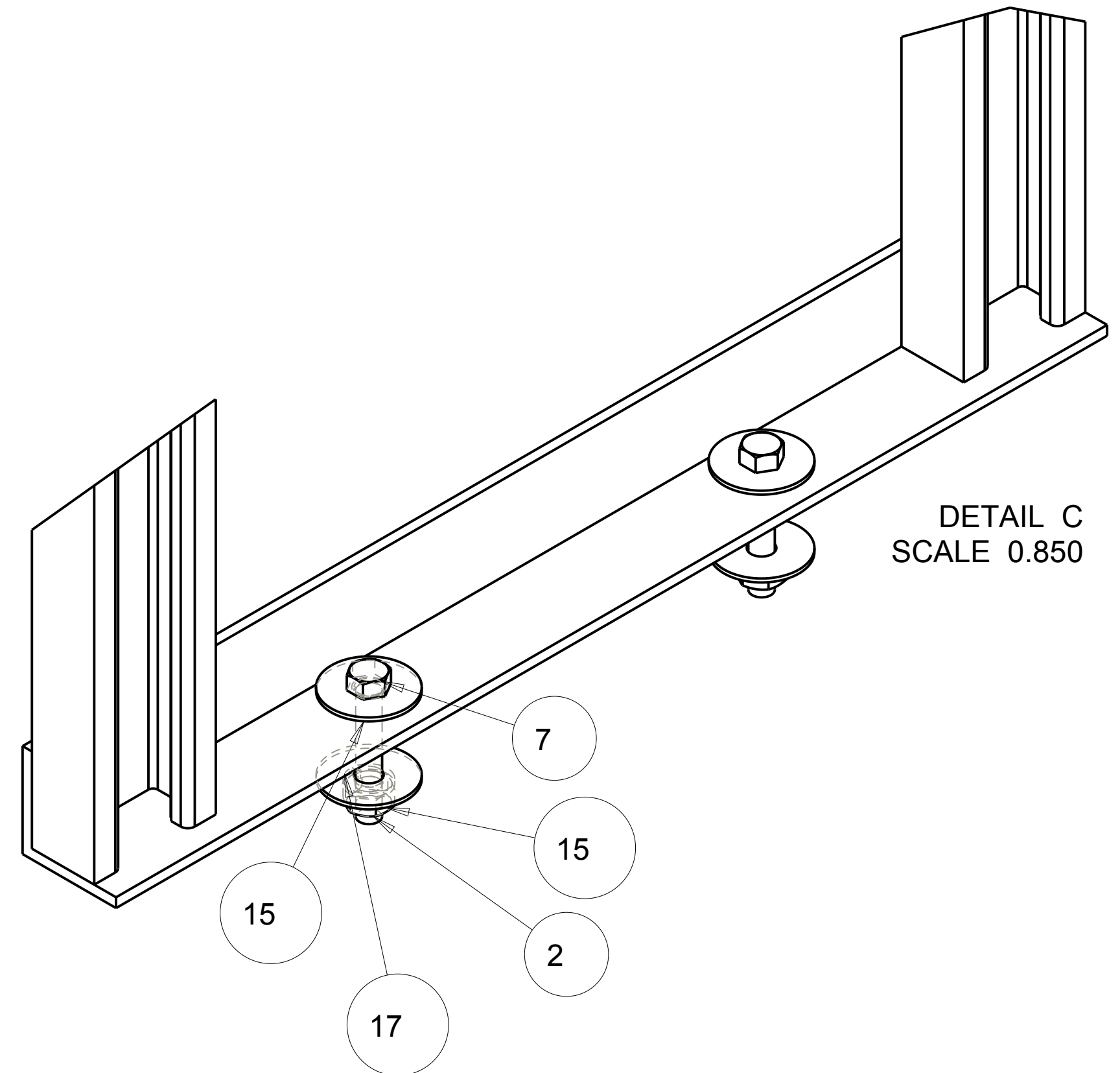
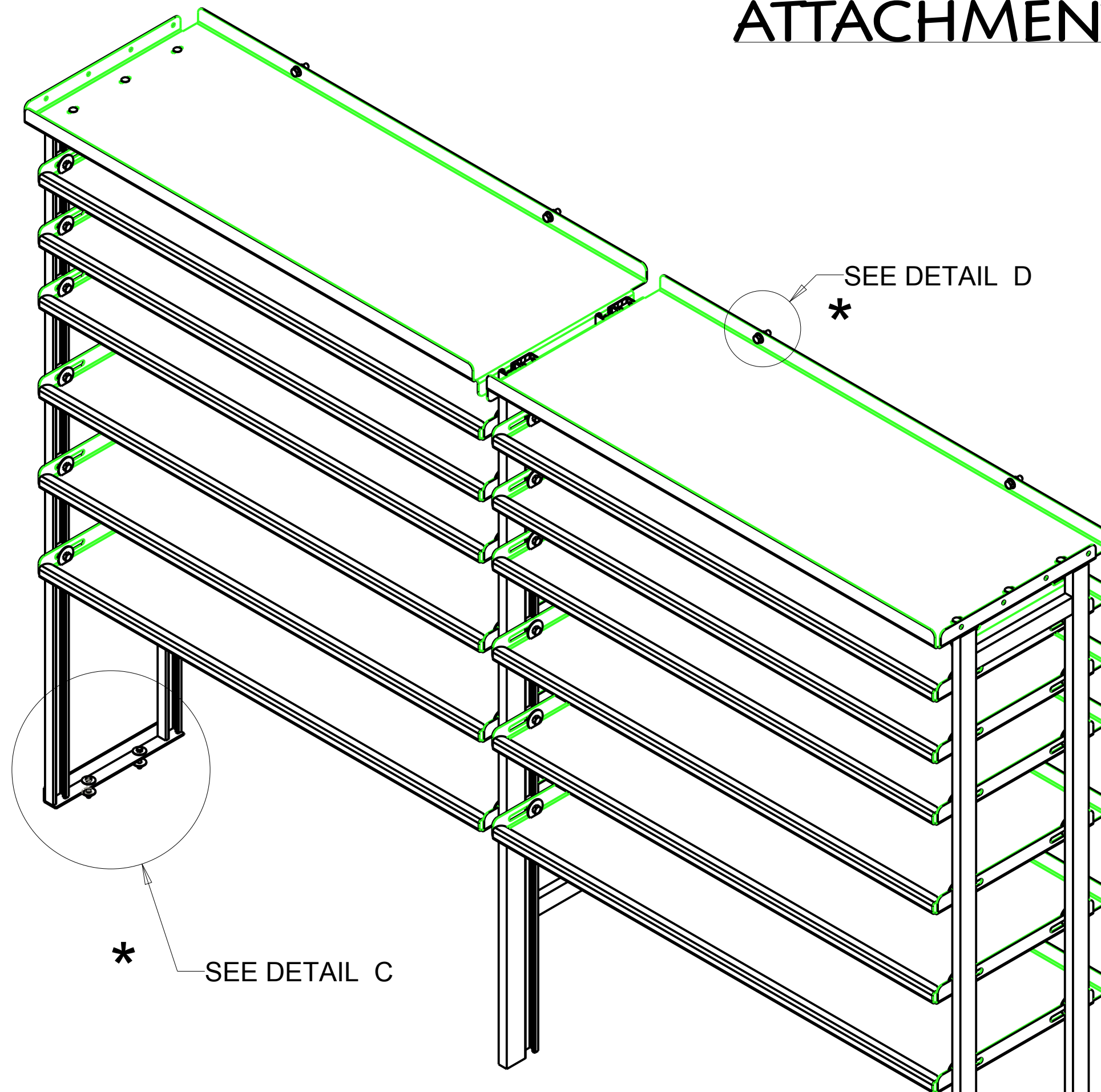

VisionComms

ATTACHMENT DETAILS



* NOTE:
BEFORE DRILLING ANY HOLE THROUGH
THE FLOOR OR WALL, VERIFY CLEARANCE
ON BACKSIDE OF HOLE.

* NOTE:
BOLT THRU IN SIDE WALL
USE 3/8" DRILL THRU.

NUMBER	WEIGHT	TOLERANCE UNLESS OTHERWISE SPECIFIED	 A company of VT Systems
SPRINTER	166.515	.XX=+/- .060 .XXX=+/- .030	
ROUTING	MATL CODE		252-946-6521 vtackney.com hackney.com kidron.com vtvisioncomms.com
ITEM NO	SHAPE DESC		
386438			 
RAW_MATL	HRS		
DRAWN BY	DATE	DESCRIPTION	
LRE	05 AUG 16	SHELF ASM. CURBSIDE SPRINTER 170"WB HIGH ROOF 46-46 STD.	
APPROVED BY	DATE		
SUPERSEDES	SUPERSEDED BY	SCALE	DWG NAME
		0.125	P16C0317 Sheet 4 of 4