

BBL NO.	ITEM DESCRIPTION	LENGTH	WIDTH	MATL CODE	QTY REQD	ITEM NO.	MODEL NAME
1	ANGLE - .10X3.00X3.00X13.25	13.250	5.805	BB2	1	386453	P16C0440
2	ANGLE-.10X1.50X1.50X 13.25	13.250	2.810	BB2	3	385287	P15C0410
3	CHANNEL-LADDER SUPPORT			BB1	4	386448	P16C0395
4	NUT-HEX .25 SST			E1	44	807862	807862
5	NUT-HEX .38 LK			E1	14	1485	1485
6	NUT-UNISTRUT W/O SPRING .38-16			C4	82	802807	802807
7	PIPE STOP SHEET	16.000	7.310	BB2	1	386422	P16C0285
8	SCREW-CARRIAGE .25X .50			E0	40	826255	826255
9	SCREW-HEX 3/8-13X 1.00 FLANGE			E1	14	1490	1490
10	SCREW-HEX.25X1.50 SST			E0	4	803172	803172
11	SCREW-HEX.38X .75 GR5	0.750		E0	82	802804	802804
12	SHEET-.12X 4.00X 19.50			BB1	1	386447	P16C0394
13	SHELF-LADDER LH	20.000	81.000	BB2	1	386449	P16C0396
14	SHELF-LADDER RH	20.000	77.000	BB2	1	386450	P16C0397
15	SHELF-TOP 18"x47.00"	47.000	18.000	BB2	1	386415	P16C0298
16	SHELF-TOP 18"x73"	73.000	18.000	BB2	1	386416	P16C0183
17	SHELF-TRAY 18"x23"	23.000	18.000	BB2	6	386376	SHELF_3_DS
18	SHELF-TRAY 18"x46"	46.000	18.000	BB2	6	385297	SHELF_1_DS
19	SHELF-TRAY 18"x46"	46.000	18.000	BB2	6	385297	SHELF_2_DS
20	SUPPORT ASM-LADDER			ZA	4	385200	385200
21	UNISTRUT ASM-DOUBLE			ZA	2	386445	386445
22	UNISTRUT ASM-SINGLE			ZA	2	386446	386446
23	WASHER-FENDER .25 SST			E2	8	820746	820746
24	WASHER-FLAT .38 D-SHAPED			E2	82	816154	816154
25	WASHER-LOCK .25 SST			E2	44	803630	803630

NOTE:  
1.) FOR OPTIONAL SHELF LINER KIT, USE PART NUMBER #386444

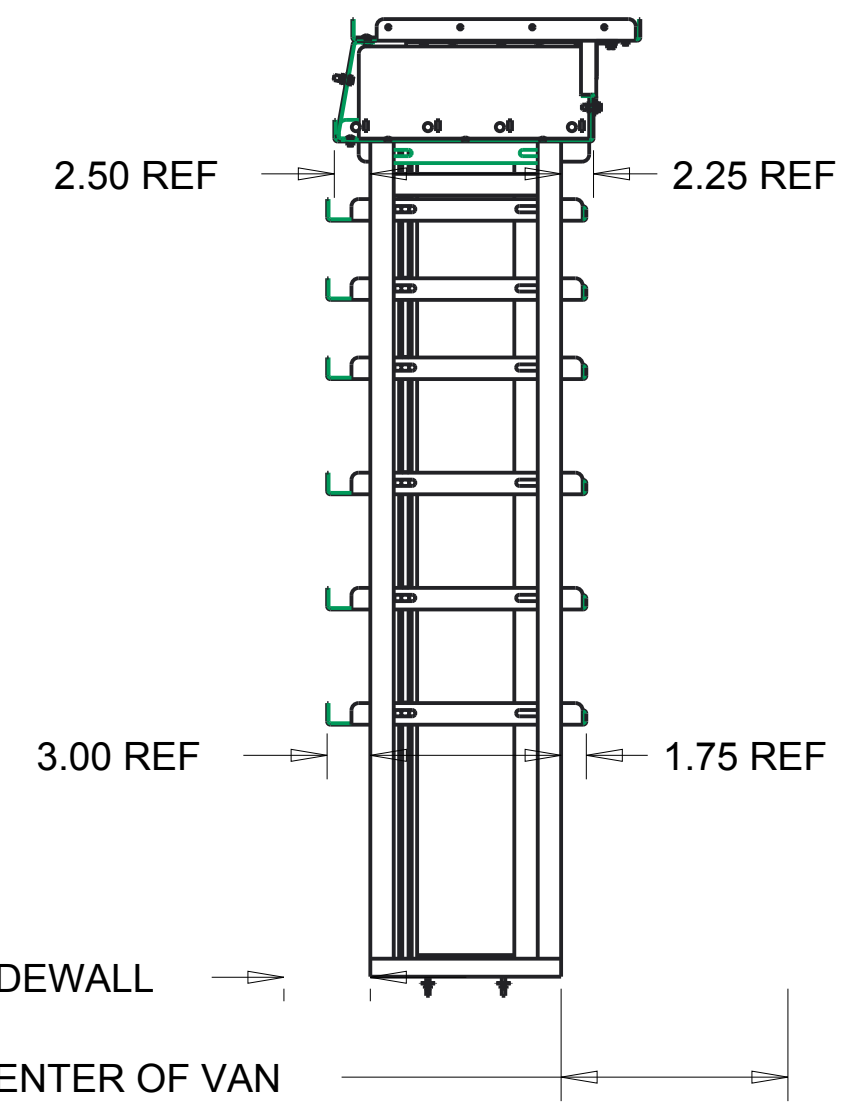

VIEW FROM REAR OF VAN

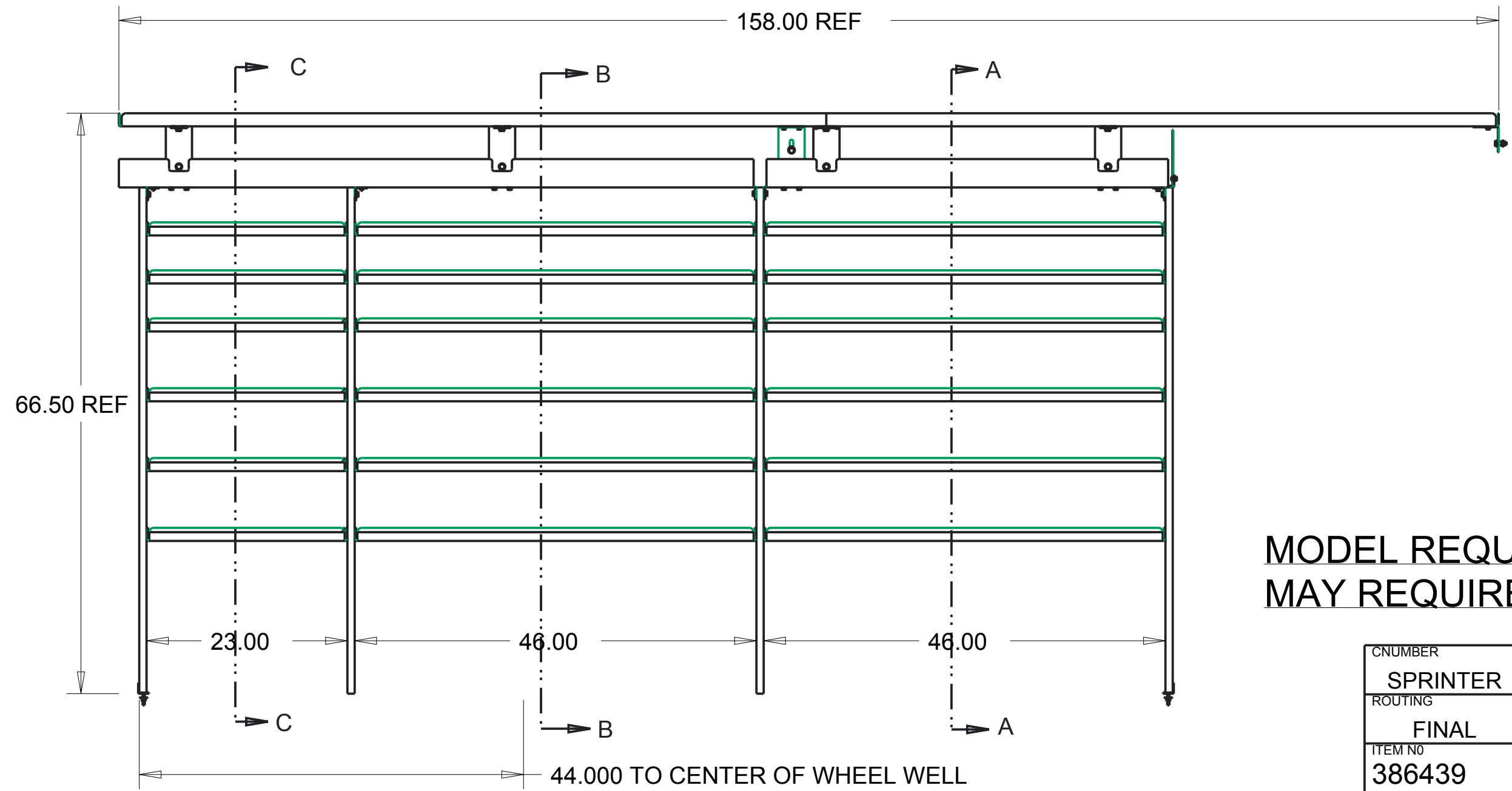

VIEW FROM AISLE

MODEL REQUIRES OEM BULKHEAD. AFTERMARKET BULKHEADS MAY REQUIRE ADDITIONAL MODIFICATION.

CNUMBER	WEIGHT	TOLERANCE UNLESS OTHERWISE SPECIFIED
SPRINTER	134.923	
ROUTING	MATL CODE	
FINAL	ZA	.XX=+/- .060 .XXX=+/- .030
ITEM NO	SHAPE DESC	
386439		
RAW_MATL	HRS	
	0.000	
DRAWN BY	DATE	
ALB	15-Jul-16	
APPROVED BY	DATE	
SUPERSEDES	SUPERSEDED BY	SCALE
		0.075

**VT Hackney** *Hackney*  
A company of VT Systems  
**Kidron**  
252-946-6521  
vtackney.com hackney.com kidron.com vtvisioncomms.com **VisionComms**

DESCRIPTION SHELF ASM.- DRIVERSIDE SPRINTER 170" WB HIGH ROOF 46-46-23

THIS PRINT AND ALL RIGHTS TO THE DESIGN AND DETAIL THEREON ARE THE PROPERTY OF VT HACKNEY AND IS LOANED TO THE RECIPIENT SUBJECT TO RETURN UPON DEMAND. ITS CONTENTS ARE CONFIDENTIAL AND MUST NOT BE COPIED OR SUBMITTED TO OUTSIDE PARTIES FOR USE OR EXAMINATION. COPYRIGHT 2016 VT HACKNEY A COMPANY OF VT SYSTEMS

REV	REVISION DESCRIPTION	ECN	DATE	INITIALS

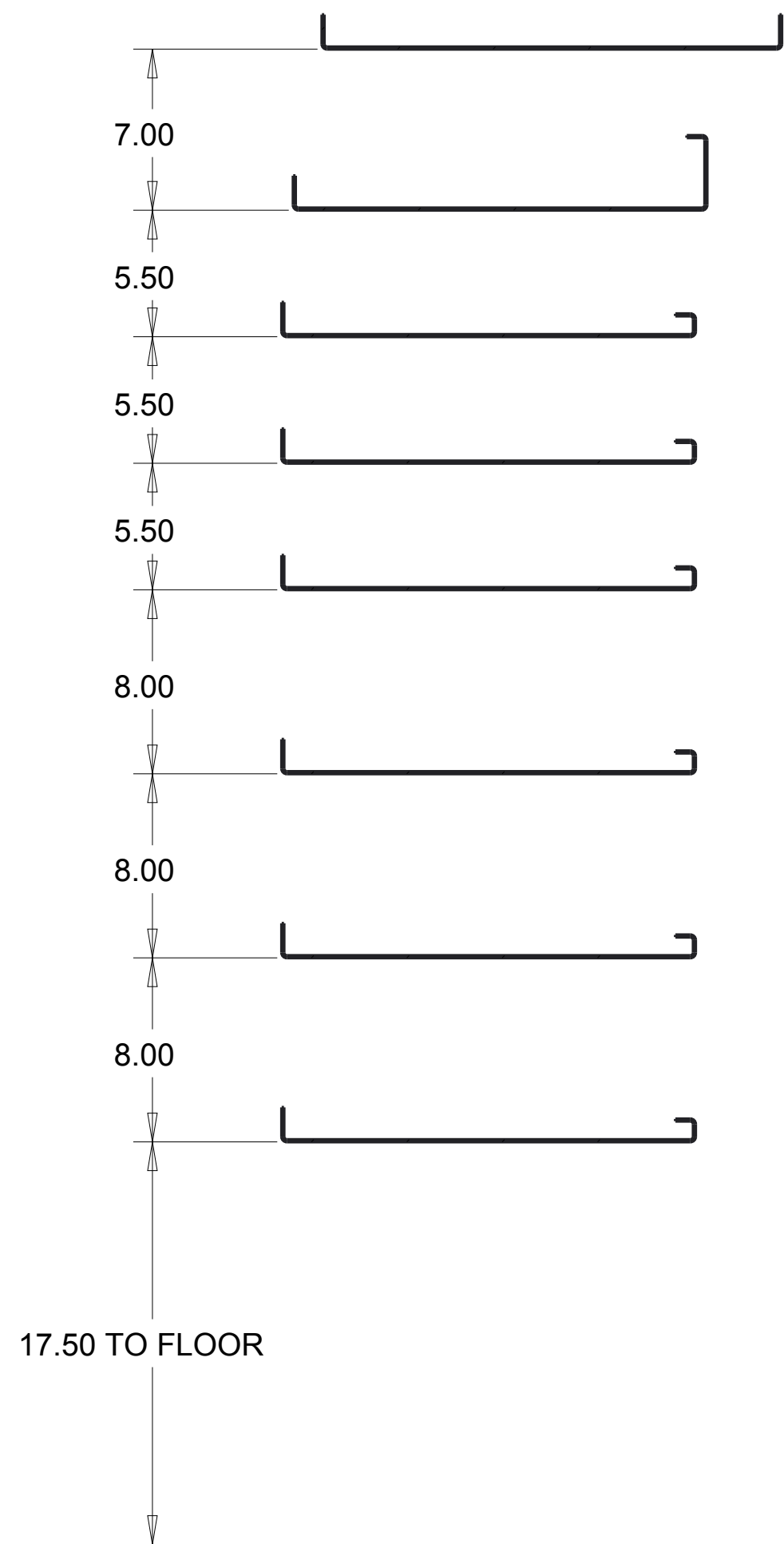

SECTION A-A

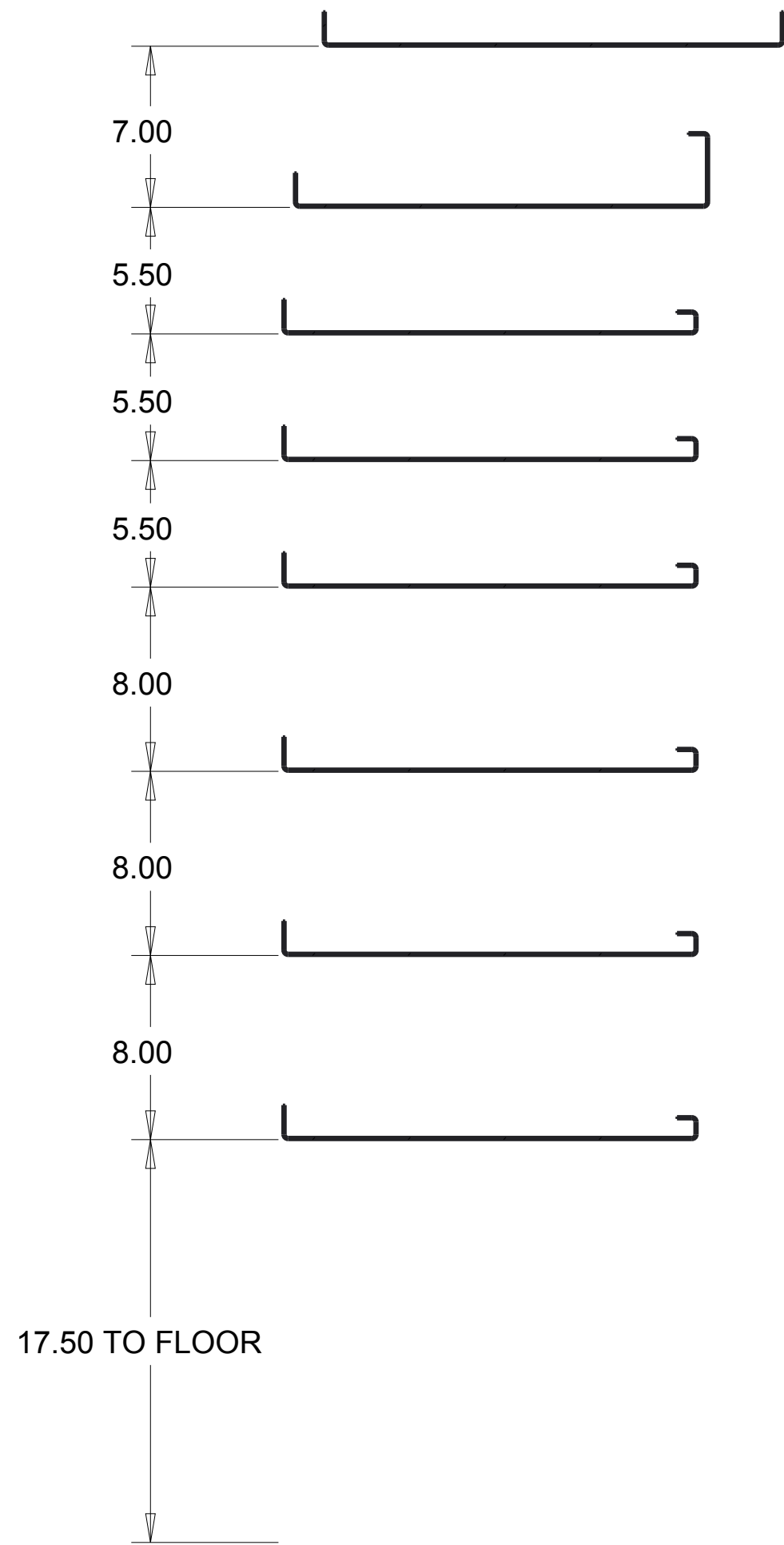

SECTION B-B

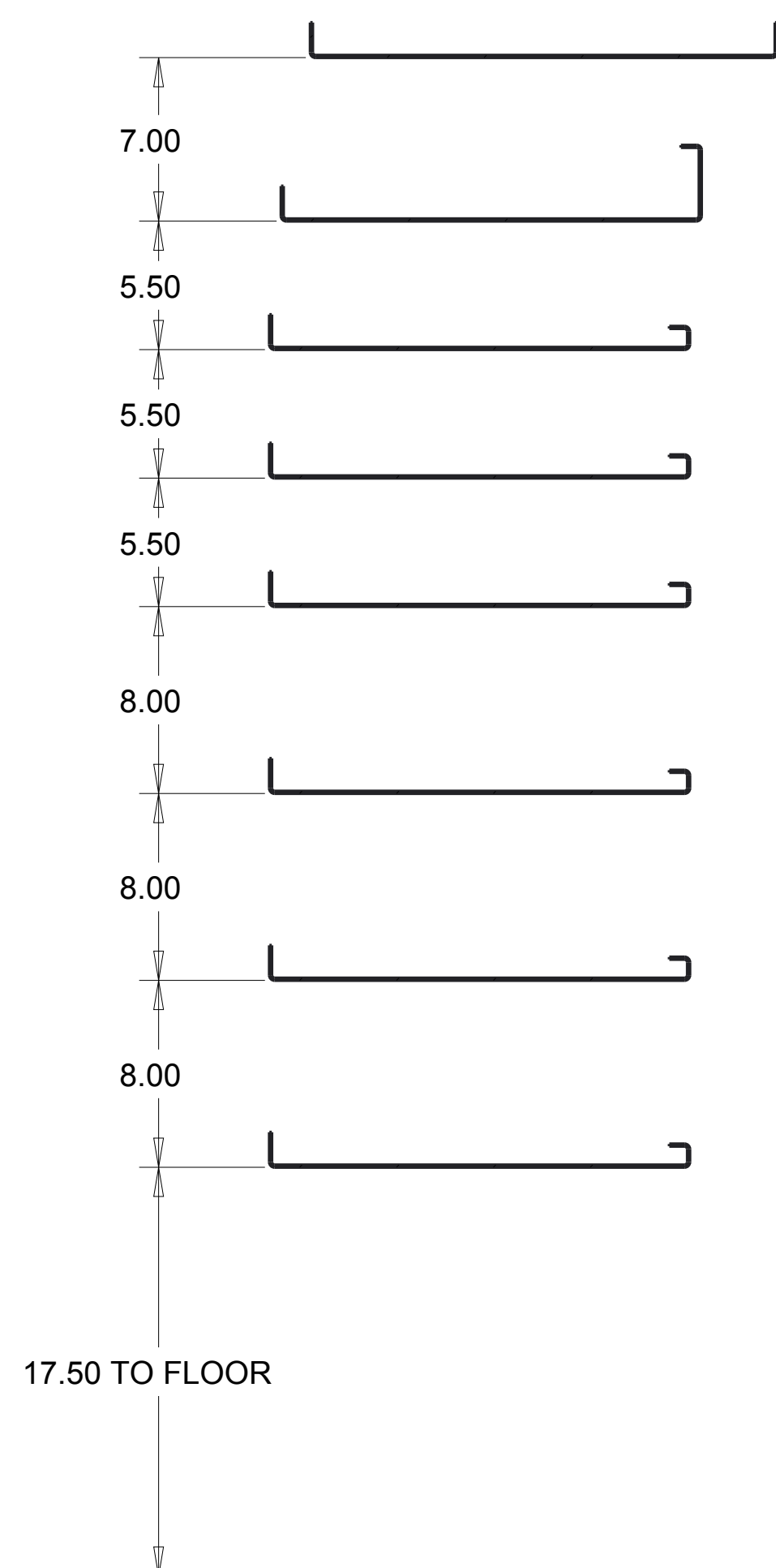

SECTION C-C

CNUMBER <b>SPRINTER</b>	WEIGHT <b>134.923</b>	TOLERANCE UNLESS OTHERWISE SPECIFIED	
ROUTING <b>FINAL</b>	MATL CODE <b>ZA</b>	.XX=+/-_.060 .XXX=+/-_.030	
ITEM NO <b>386439</b>	SHAPE DESC		
RAW_MATL	HRS <b>0.000</b>	DESCRIPTION	
DRAWN BY	DATE <b>15-Jul-16</b>	vtackney.com hackney.com kidron.com vtvisioncomms.com	
APPROVED BY	DATE	SHELF ASM.- DRIVERSIDE SPRINTER 170" WB HIGH ROOF 46-46-23	
SUPERSEDES	SUPERSEDED BY	SCALE <b>0.150</b>	DWG NAME <b>P16C0316 Sheet 2 of 4</b>



**VT Hackney**  
A company of VT Systems

*Hackney*



252-946-6521

**VisionComms**

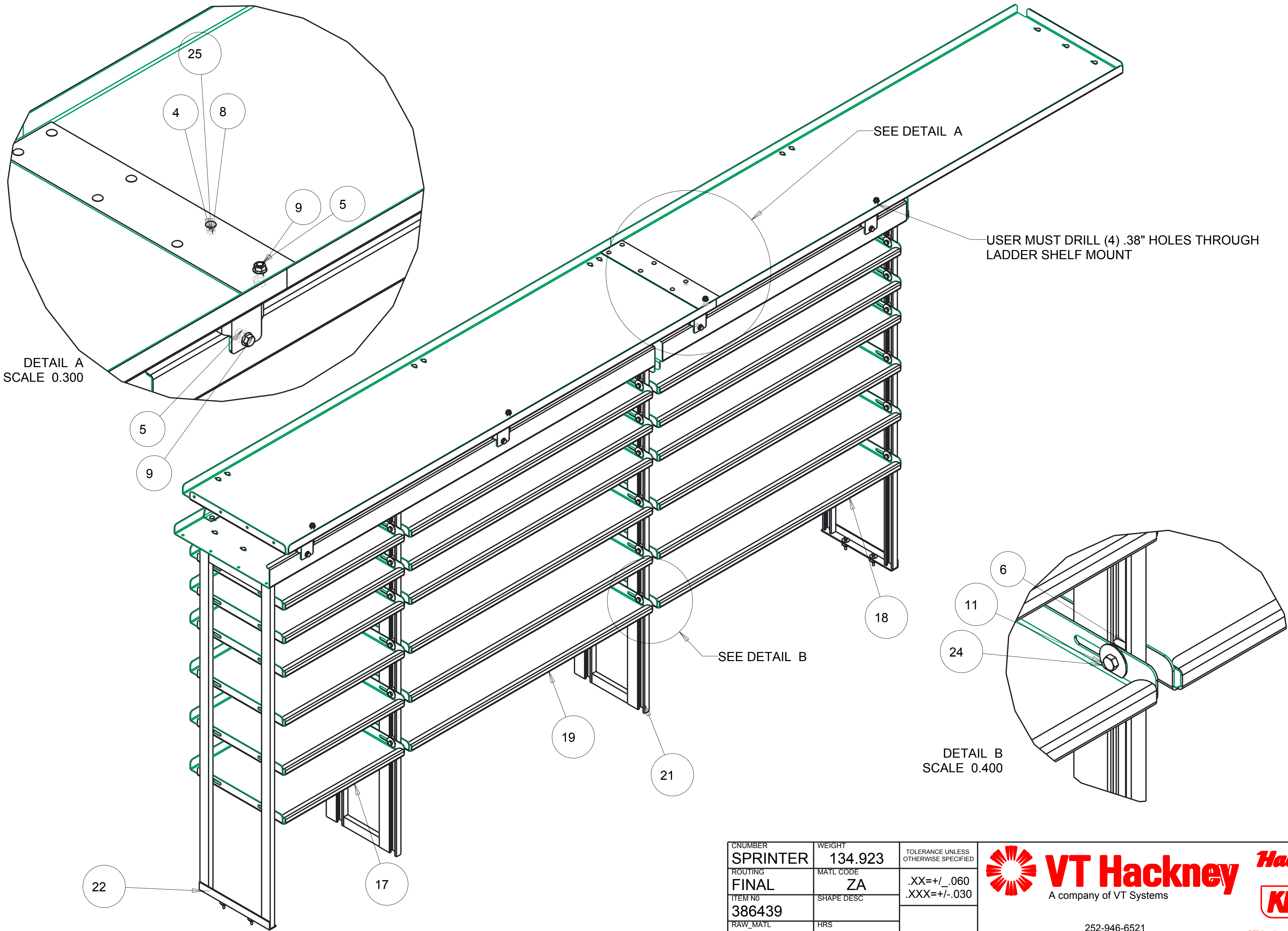

DETAIL A  
SCALE 0.300

SEE DETAIL A

USER MUST DRILL (4) .38" HOLES THROUGH  
LADDER SHELF MOUNT

SEE DETAIL B

DETAIL B  
SCALE 0.400

CNUMBER	WEIGHT	TOLERANCE UNLESS OTHERWISE SPECIFIED
SPRINTER	134.923	
ROUTING	MATL CODE	.XX=+/- .060
FINAL	ZA	.XXX=+/- .030
ITEM NO	SHAPE DESC	
386439		
RAW_MATL	HRS	
	0.000	
DRAWN BY	DATE	DESCRIPTION
ALB	18-Jul-16	SHELF ASM.- DRIVERSIDE SPRINTER 170" WB HIGH ROOF 46-46-23
APPROVED BY	DATE	
SUPERSEDES	SUPERSEDED BY	SCALE
		0.034
		DWG NAME
		P16C0316 Sheet 3 of 4

**VT Hackney** *Hackney*  
A company of VT Systems **Kidron**

252-946-6521  
vthackney.com hackney.com kidron.com vtvisioncomms.com **VisionComms**

**INSTALLATION NOTES:**

1.) INSTALLER RESPONSIBLE FOR SECURING SHELVING UNIT TO THE VAN USING SUPPLIED HARDWARE NOTED IN DETAILS C, D, AND E.

2.) BEFORE DRILLING ANY HOLE THROUGH FLOOR OR WALL, VERIFY CLEARANCE ON BACKSIDE OF HOLE.

# ATTACHMENT DETAILS

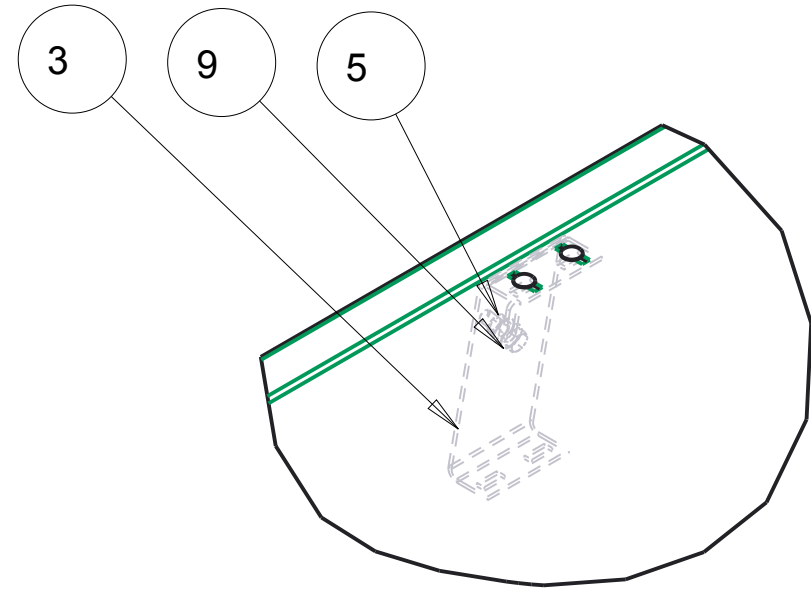

DETAIL E  
SCALE 0.200

SEE DETAIL E

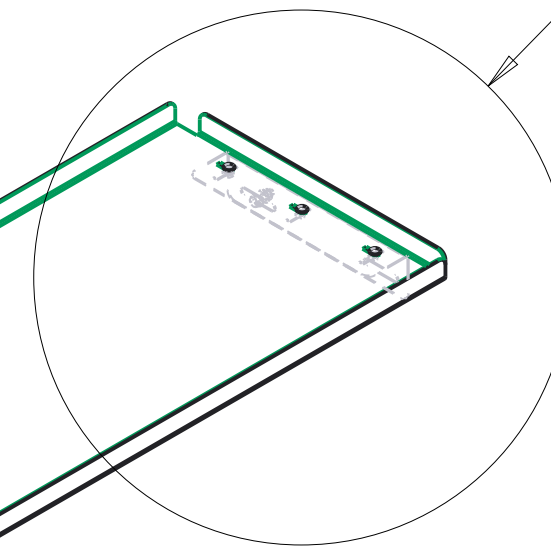

SEE DETAIL C

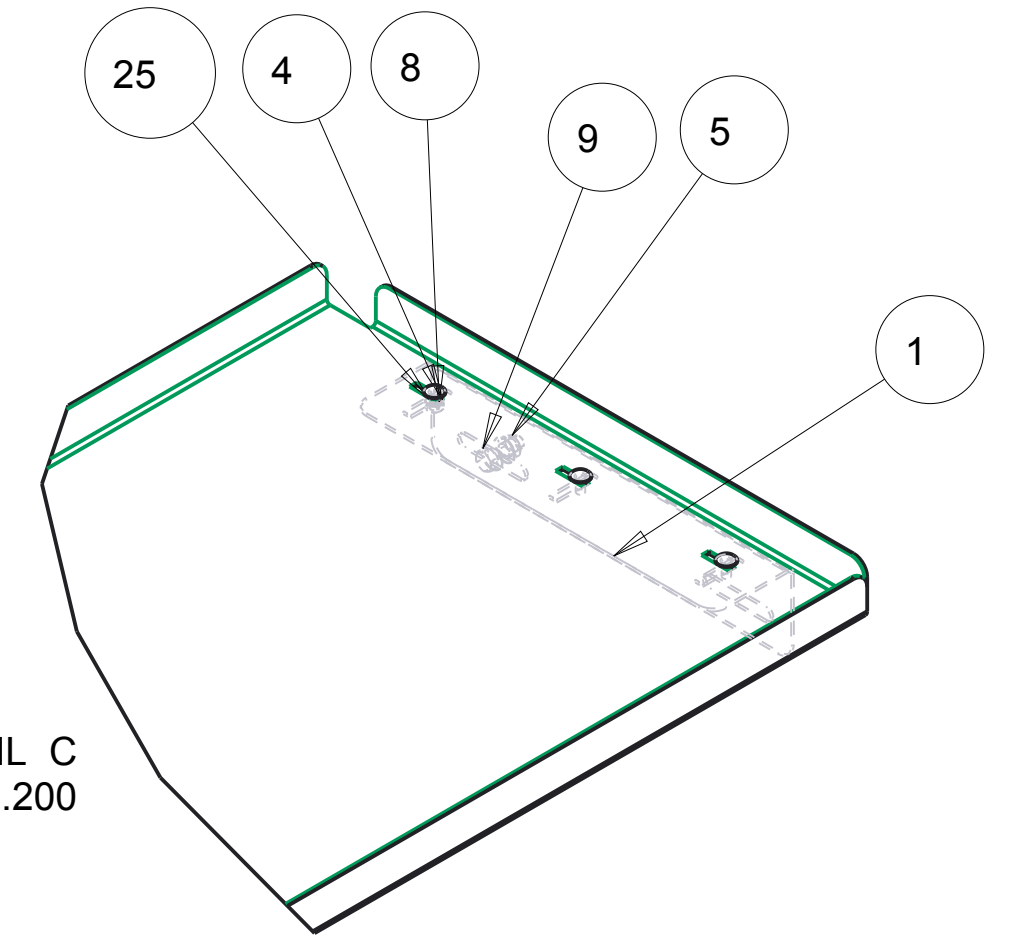

DETAIL C  
SCALE 0.200

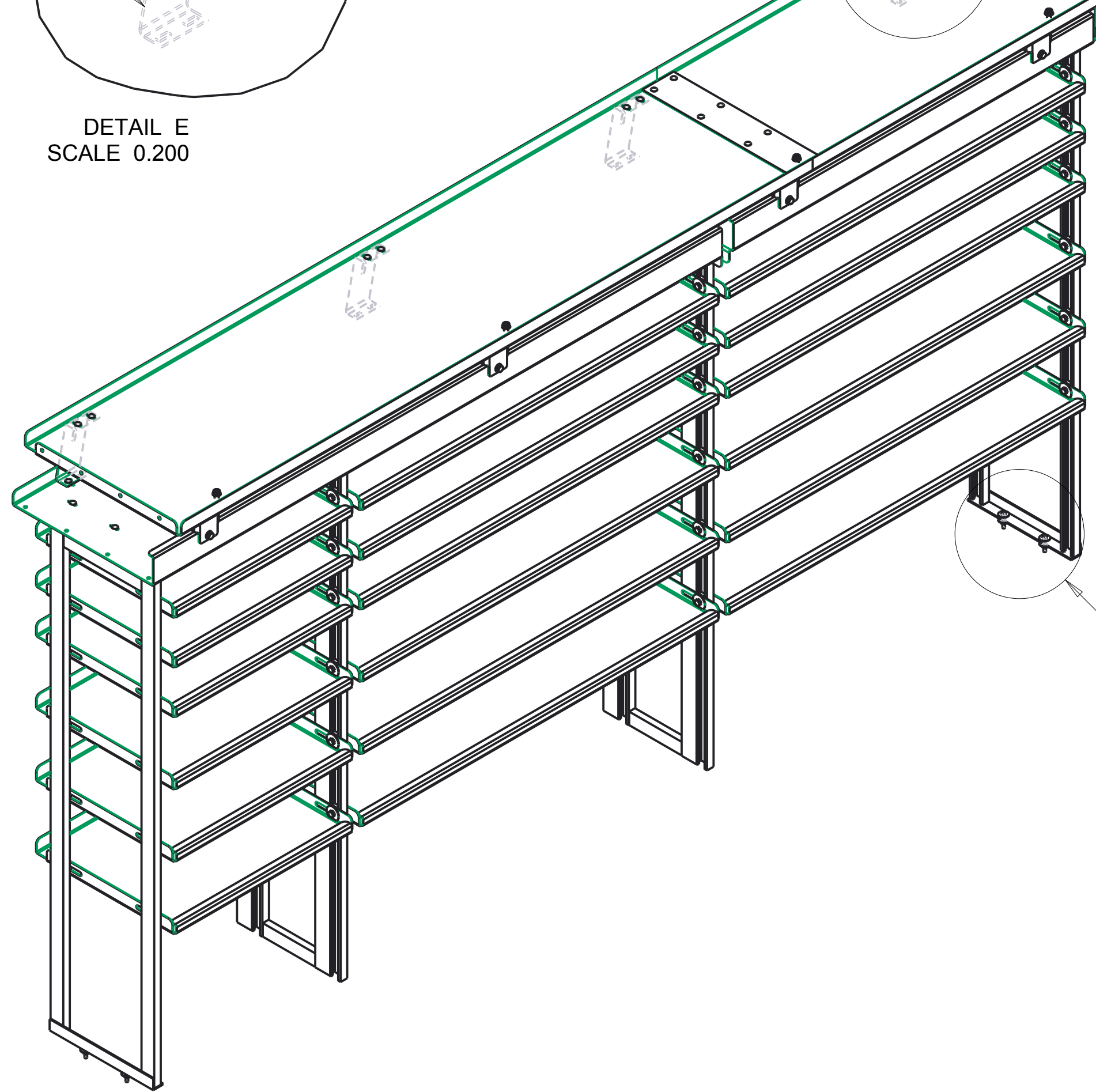

SEE DETAIL D

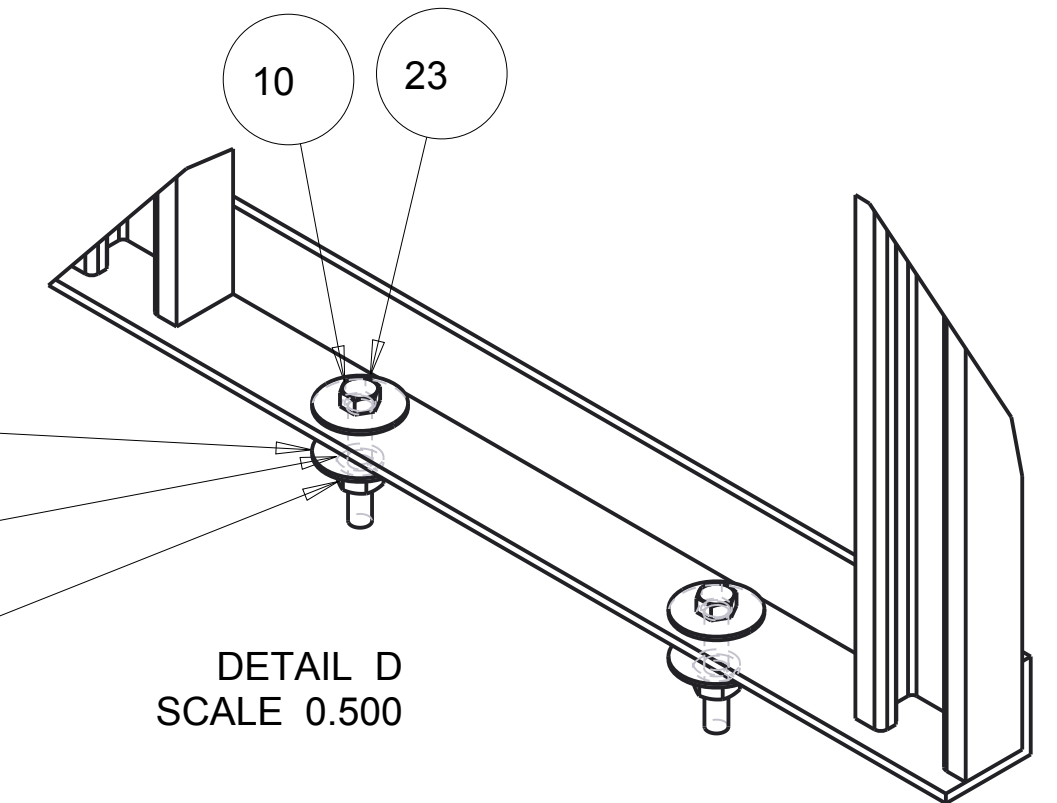

DETAIL D  
SCALE 0.500

SCALE 0.100

CNUMBER	WEIGHT	TOLERANCE UNLESS OTHERWISE SPECIFIED
SPRINTER	134.923	
ROUTING	MATL CODE	.XX=+/-_.060
FINAL	ZA	.XXX=+/-_.030
ITEM NO	SHAPE DESC	
386439		
RAW_MATL	HRS	DESCRIPTION
	0.000	vtackney.com hackney.com kidron.com vtvisioncomms.com
DRAWN BY	DATE	SHELF ASM.- DRIVERSIDE SPRINTER 170" WB HIGH ROOF 46-46-23
ALB	18-Jul-16	
APPROVED BY	DATE	SCALE
		0.034
SUPERSEDES	SUPERSEDED BY	DWG NAME
		P16C0316 Sheet 4 of 4



252-946-6521  
vtackney.com hackney.com kidron.com vtvisioncomms.com

