

NOTES:  
1. FOR OPTIONAL SHELF LINER KIT, USE #385506.

BBL NO.	ITEM DESCRIPTION	LENGTH	WIDTH	WEIGHT	MATL CODE	ITEM NUMBER		MODEL NAME
						QTY REQD	ITEM NO.	
1	ANGLE-.10X1.50X1.50X 13.25	13.250	2.810	0.334	BB2	3	385287	P15C0410
2	ANGLE-.12X1.25X1.25X 3.00	3.000	2.472	0.084	BB1	4	385505	385505
3	NUT-HEX .25 SST			0.007	E1	13	807862	807862
4	NUT-HEX 0.38 LK			0.018	E1	4	1485	1485
5	NUT-UNISTRUT W/O SPRING .38-16			0.086	C4	54	802807	802807
6	SCREW-CARRIAGE .25X .50			0.014	E0	9	826255	826255
7	SCREW-HEX 3/8-13X 1.00 FLANGE			0.059	E1	4	1490	1490
8	SCREW-HEX. LAG 31X 1.25 FLANGE	1.280		0.042	E0	8	811914	811914
9	SCREW-HEX.25X1.50 SST			0.027	E0	4	803172	803172
10	SCREW-HEX.38X .75 GR5	0.750		0.043	E0	54	802804	802804
11	SHELF-TOP 18"x71.50"	71.500	18.000	14.661	BB2	1	385529	P16C0362
12	SHELF-TRAY 18"x23"	23.000	18.000	4.981	BB2	6	386376	SHELF1_CS
13	SHELF-TRAY 18"x46"	46.000	18.000	9.633	BB2	6	385297	SHELF2_CS
14	UNISTRUT ASM-DOUBLE			9.296	ZA	1	385522	385522
15	UNISTRUT ASM-SINGLE			6.141	ZA	2	385500	385500
16	WASHER-FENDER .25 SST			0.009	E2	8	820746	820746
17	WASHER-FLAT .38 D-SHAPED			0.007	E2	54	816154	816154
18	WASHER-LOCK .25 SST			0.002	E2	13	803630	803630

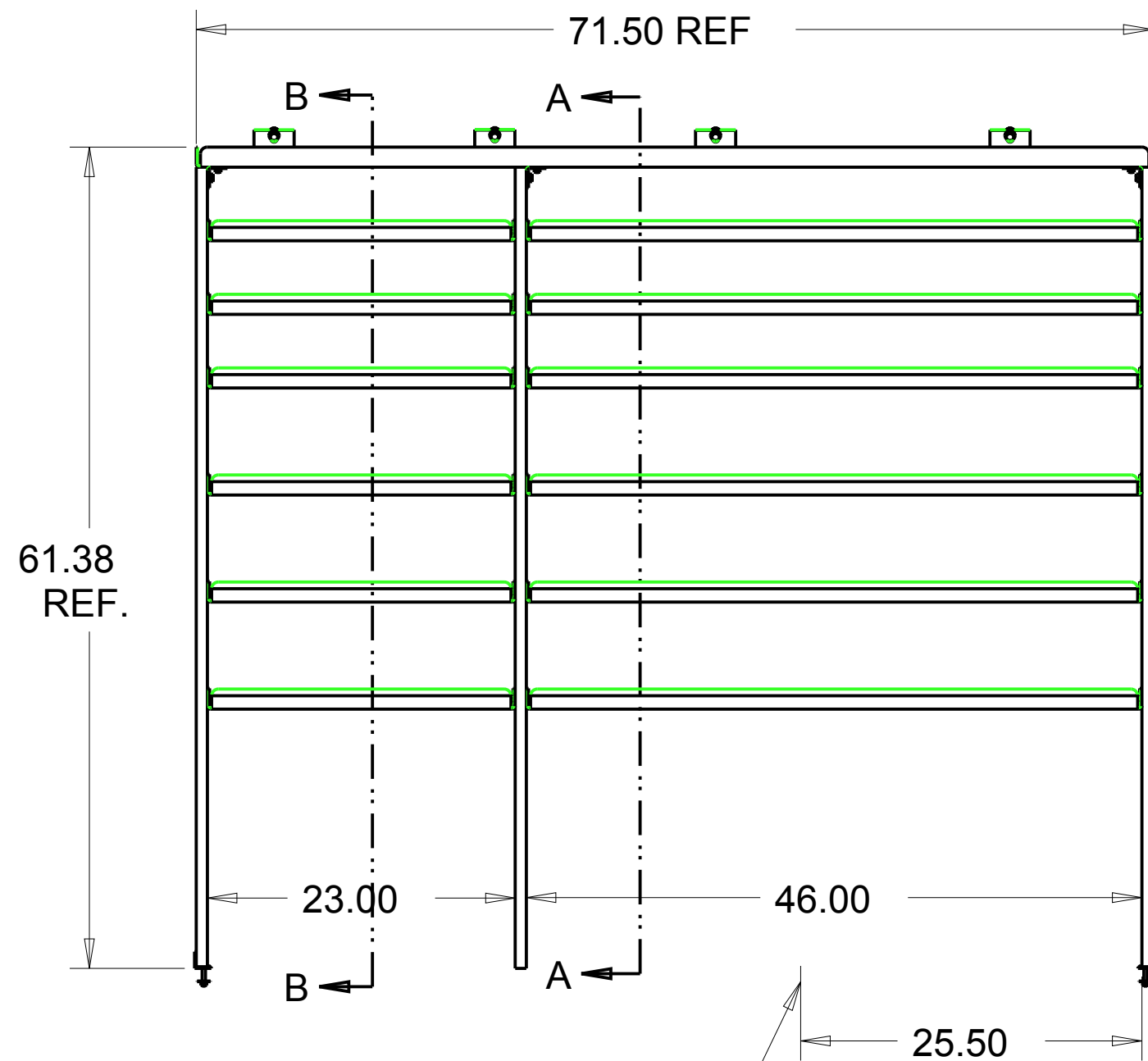

CENTERLINE OF WHEELWELL  
VIEWED FROM AISLE

REAR OF VAN

CENTERLINE OF VAN BODY

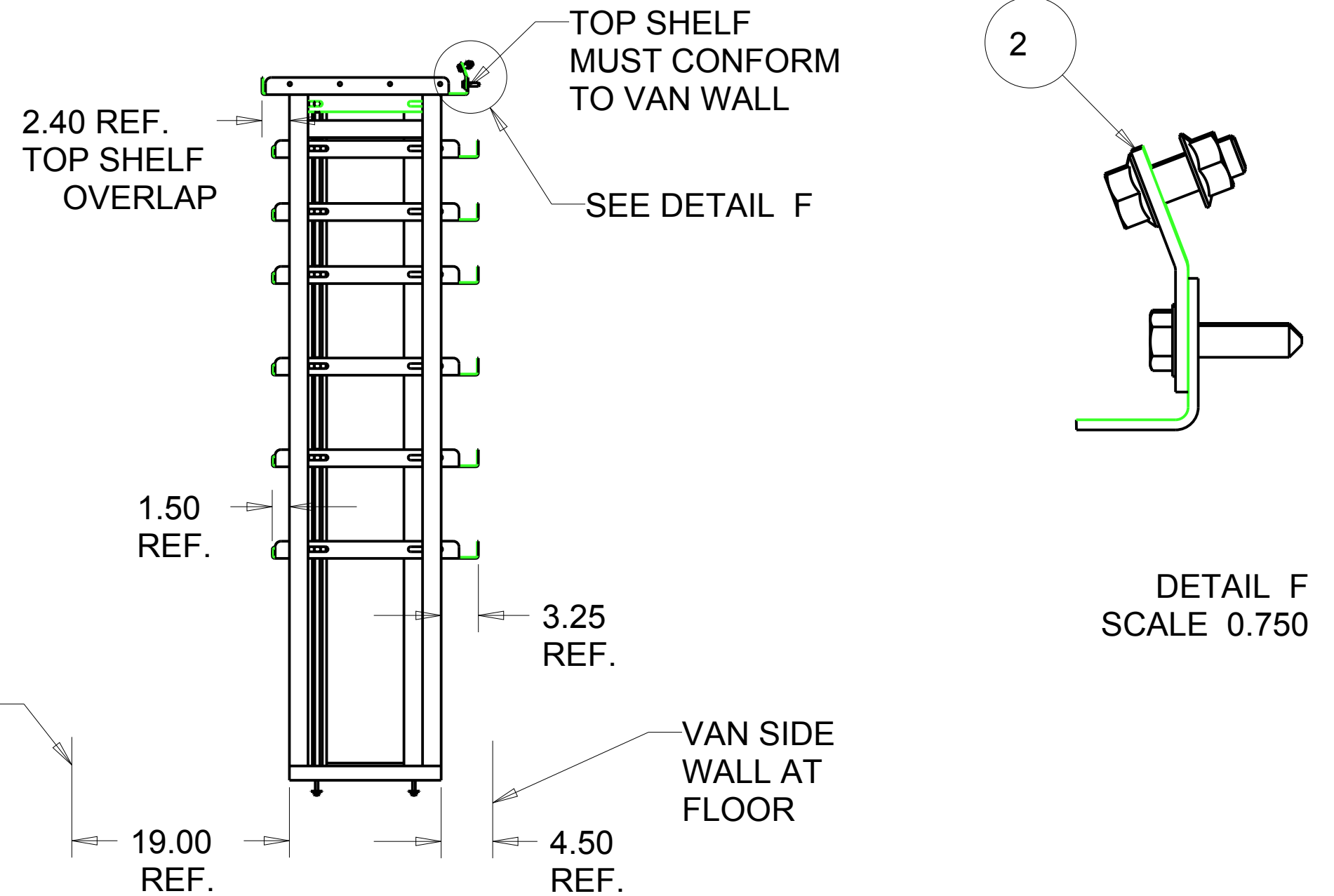

DETAIL F  
SCALE 0.750

NUMBER	WEIGHT	TOLERANCE UNLESS OTHERWISE SPECIFIED
PROMASTER 134.808		
ROUTING	MATL CODE	.XX=+/- .060 .XXX=+/- .030
FINAL	ZA	
ITEM NO	SHAPE DESC	
385496		
RAW_MATL	HRS	
	0.000	
DRAWN BY	DATE	DESCRIPTION
LCS	1 JUN 16	vthackney.com hackney.com kidron.com vtvisioncomms.com
APPROVED BY	DATE	
SUPERSEDES	SUPERSEDED BY	SCALE
		0.085



252-946-6521  
vthackney.com hackney.com kidron.com vtvisioncomms.com

SHELF ASM.- CURBSIDE PROMASTER 159"WB HIGH ROOF 23-46

REV	REVISION DESCRIPTION	ECN	DATE	INITIALS

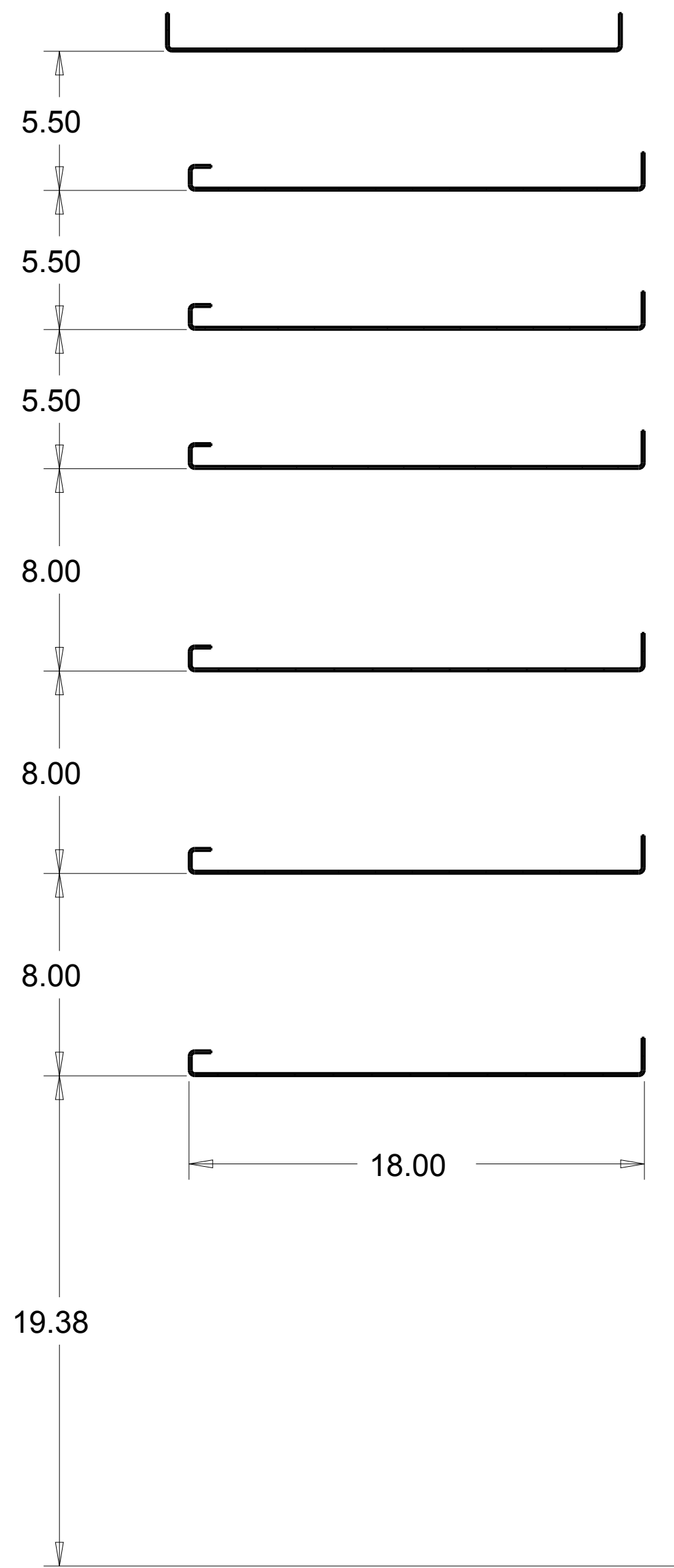

THIS PRINT AND ALL RIGHTS TO THE DESIGN AND DETAIL THEREON ARE THE PROPERTY OF VT HACKNEY AND IS LOANED TO THE RECIPIENT SUBJECT TO RETURN UPON DEMAND. ITS CONTENTS ARE CONFIDENTIAL AND MUST NOT BE COPIED OR SUBMITTED TO OUTSIDE PARTIES FOR USE OR EXAMINATION. COPYRIGHT 2016 VT HACKNEY A COMPANY OF VT SYSTEMS

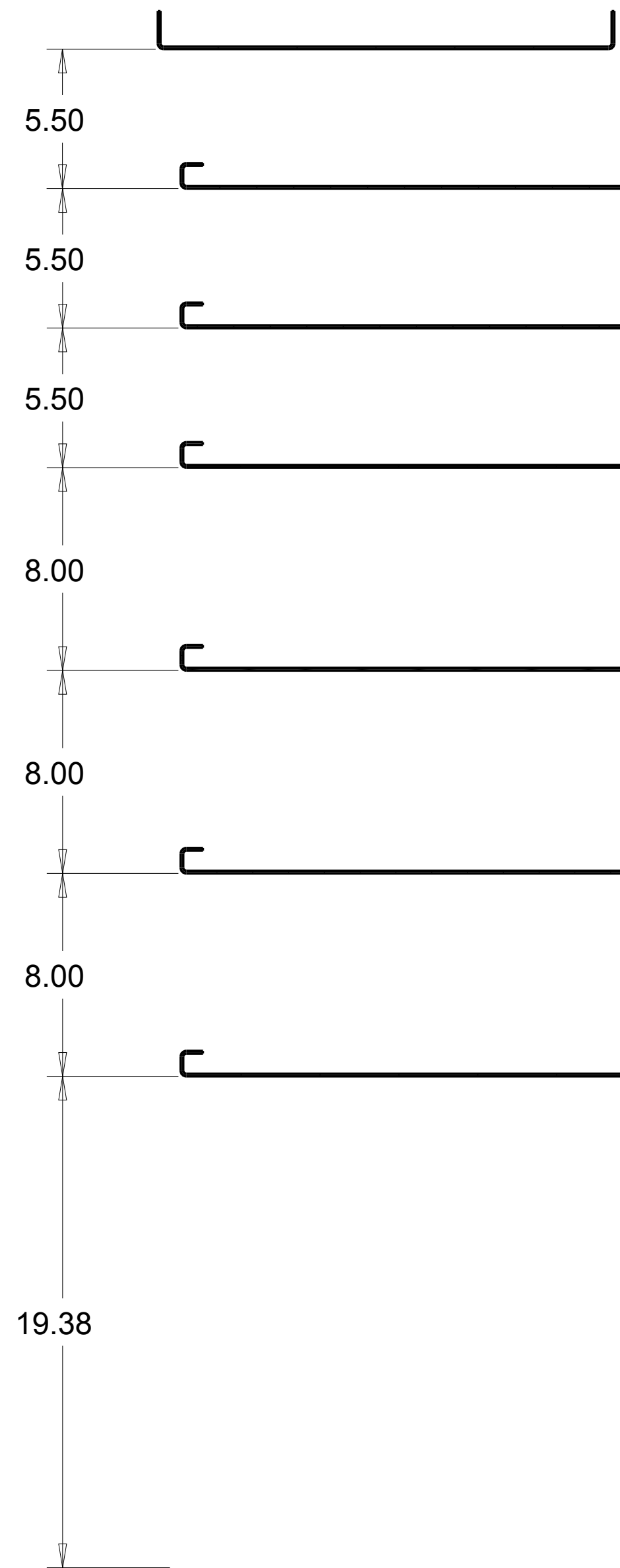

SECTION A-A



SECTION B-B

CNUMBER	WEIGHT	TOLERANCE UNLESS OTHERWISE SPECIFIED	 <b>VT Hackney</b> <i>Hackney</i> A company of VT Systems  252-946-6521 vtackney.com hackney.com kidron.com vtvisioncomms.com <b>VisionComms</b>
ROUTING	MATL CODE		
FINAL	ZA	.XX=+/- .060 .XXX=+/- .030	
ITEM NO	SHAPE DESC		
385496			
RAW_MATL	HRS		
	0.000		
DRAWN BY	DATE	DESCRIPTION	
LCS	1 JUN 16	SHELF ASM.- CURBSIDE PROMASTER 159"WB HIGH	
APPROVED BY	DATE	ROOF 23-46	
SUPERSEDES	SUPERSEDED BY	SCALE	DWG NAME
		0.200	P16C0293 Sheet 2 of 4

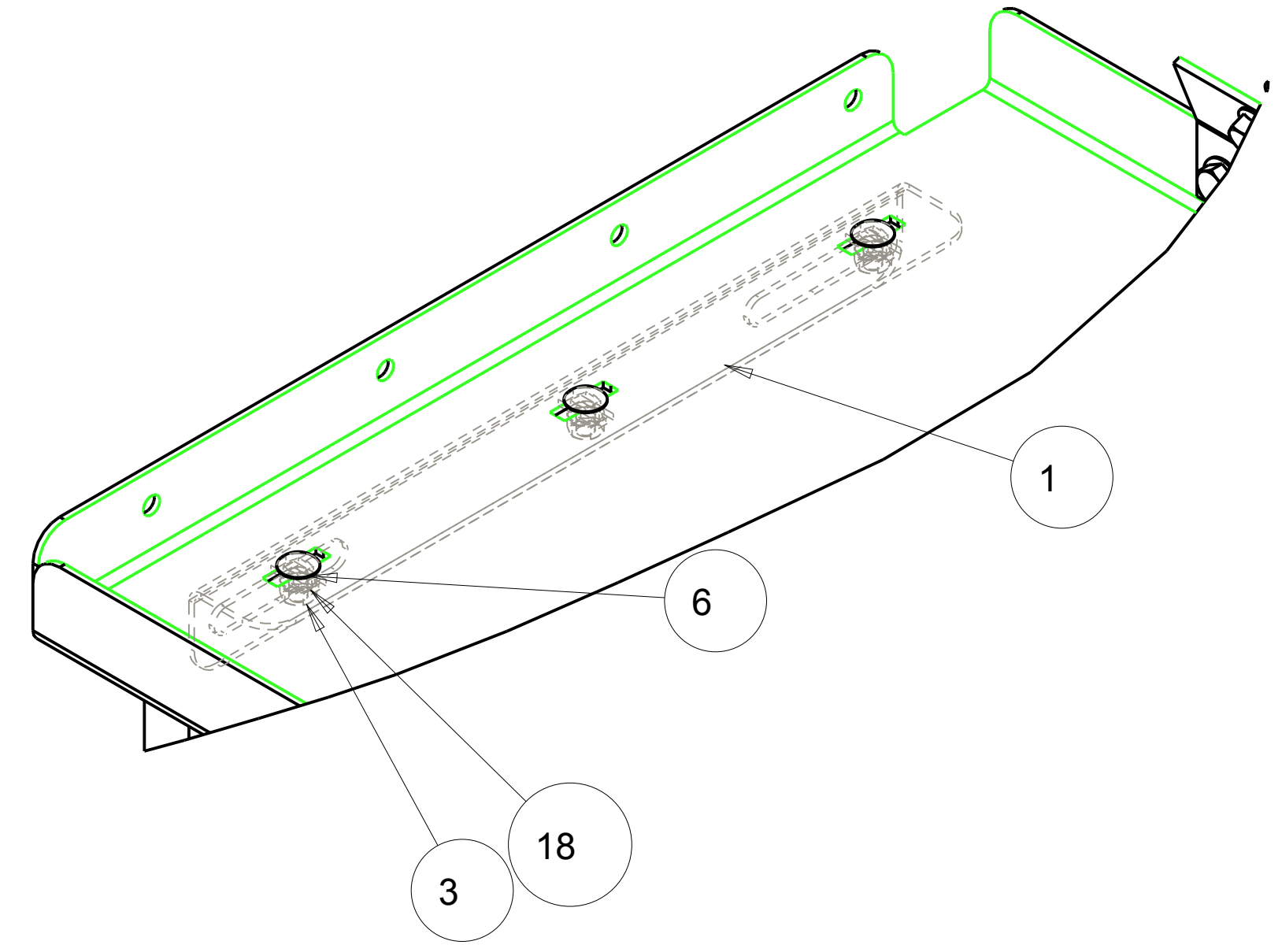
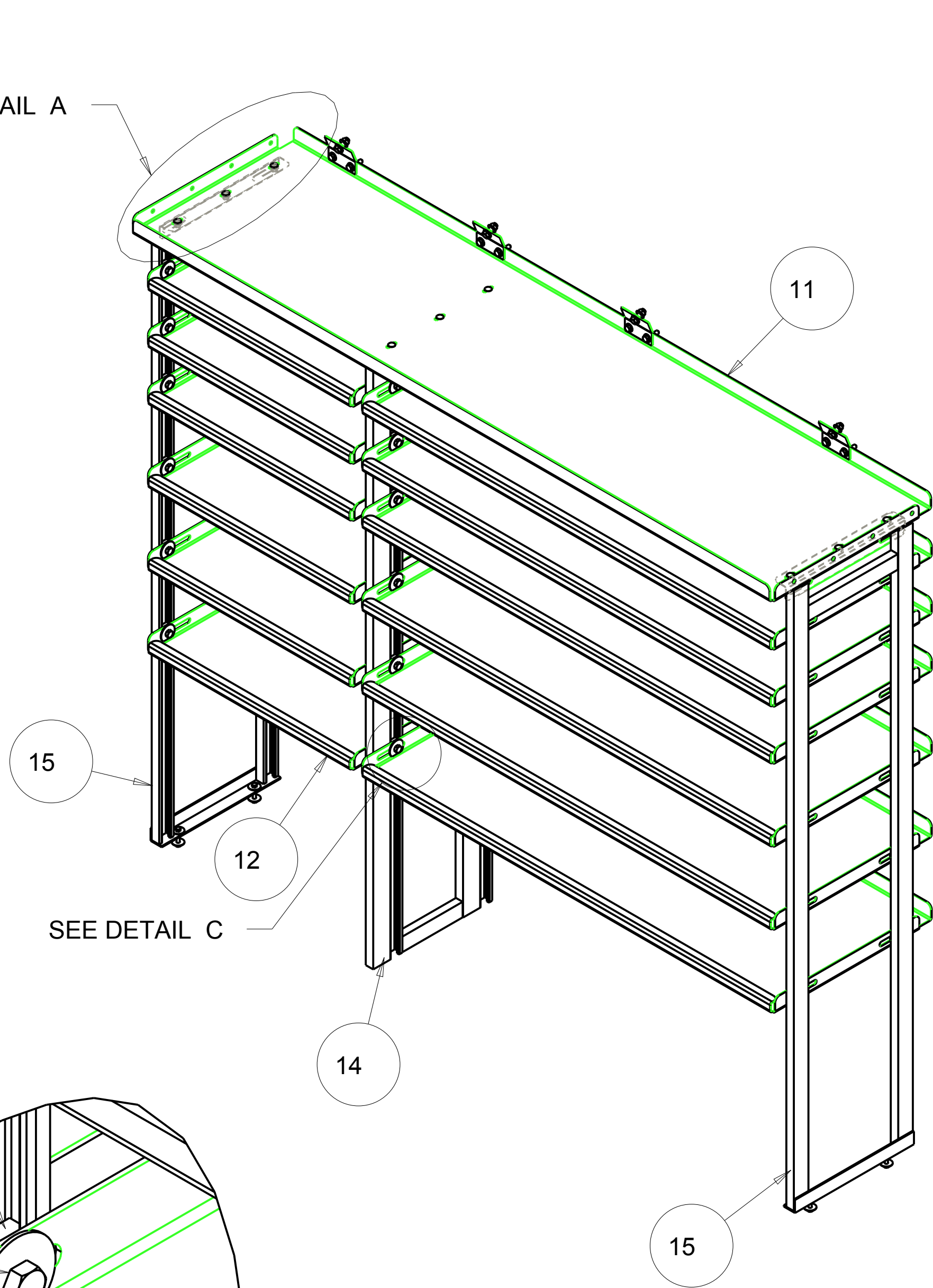

SEE DETAIL A

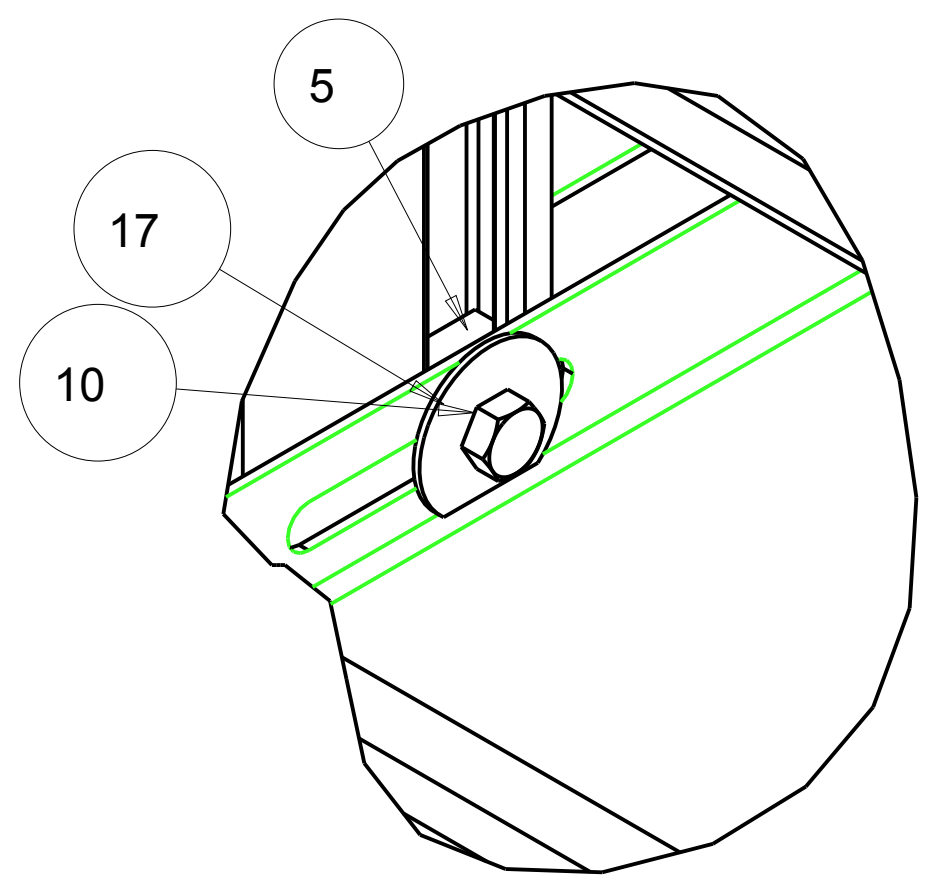

DETAIL A  
SCALE 0.500



TYP. SHELF HARDWARE  
DETAIL C  
SCALE 0.700

NUMBER <b>PROMASTER 134.808</b>	WEIGHT <b>0.000</b>	TOLERANCE UNLESS OTHERWISE SPECIFIED	 <b>VT Hackney</b> A company of VT Systems  252-946-6521 vtackney.com hackney.com kidron.com vtvisioncomms.com <b>VisionComms</b>
ROUTING <b>FINAL</b>	MATL CODE <b>ZA</b>	.XX=+/- .060 .XXX=+/- .030	
ITEM NO <b>385496</b>	SHAPE DESC		
RAW_MATL	HRS		
DRAWN BY <b>LCS</b>	DATE <b>1 JUN 16</b>	DESCRIPTION	
APPROVED BY	DATE	<b>SHELF ASM.- CURBSIDE PROMASTER 159"WB HIGH ROOF 23-46</b>	
SUPERSEDES	SUPERSEDED BY	SCALE <b>0.125</b>	DWG NAME <b>P16C0293 Sheet 3 of 4</b>

# ATTACHMENT DETAILS

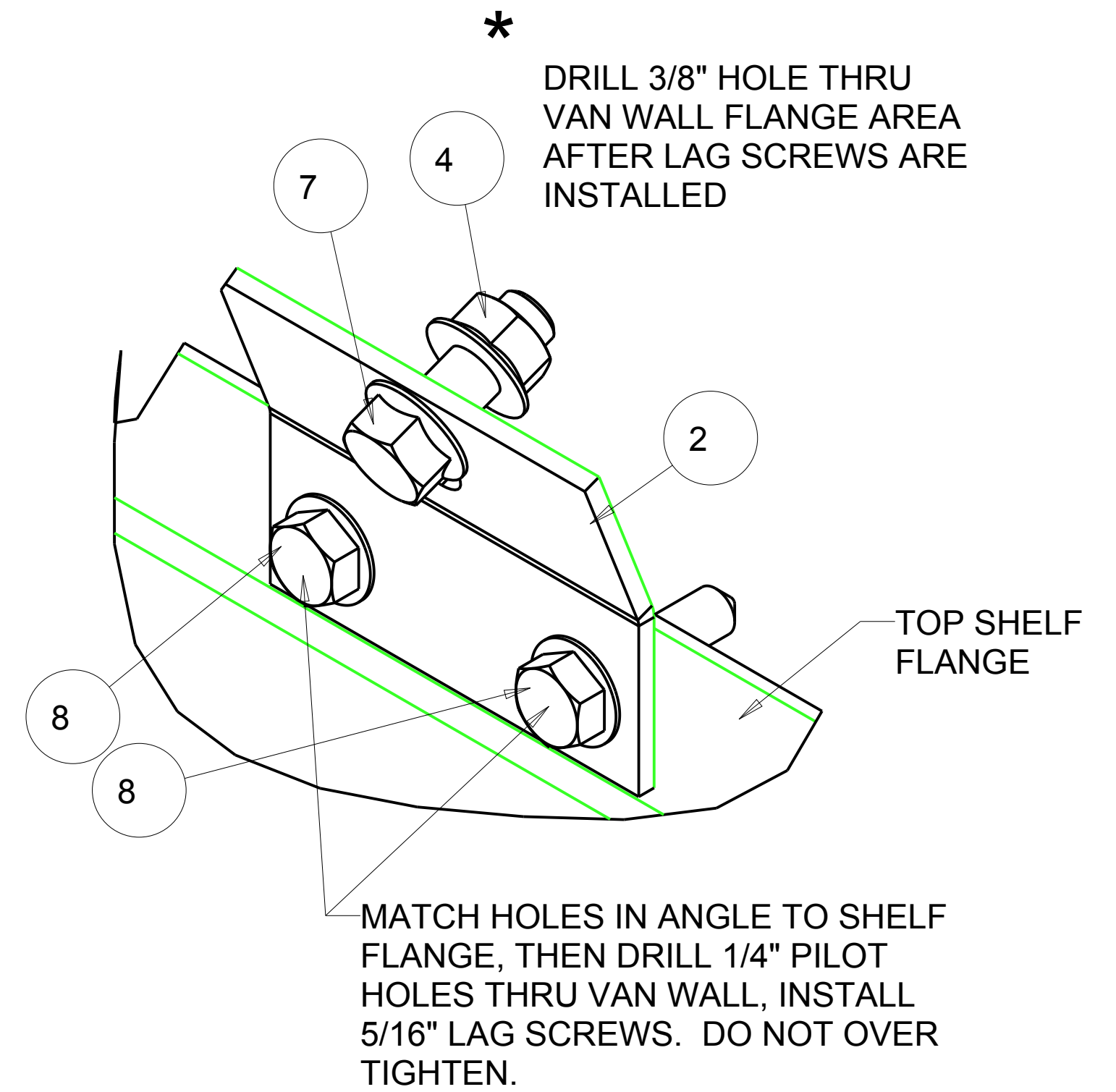
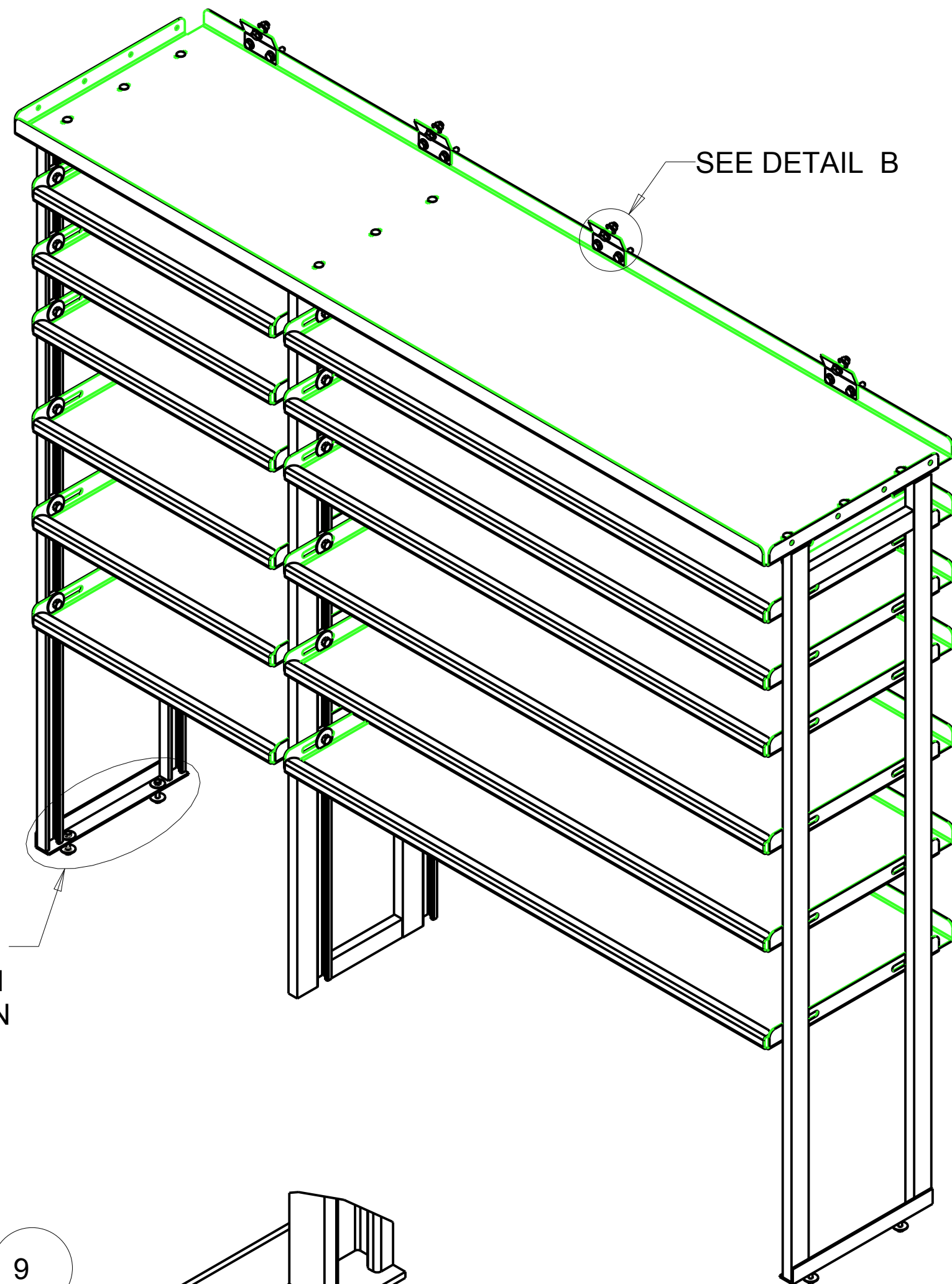

DETAIL B  
SCALE 1.250

**\* NOTE:**  
BEFORE DRILLING ANY HOLE THROUGH  
THE FLOOR OR WALL, VERIFY CLEARANCE  
ON BACKSIDE OF HOLE.

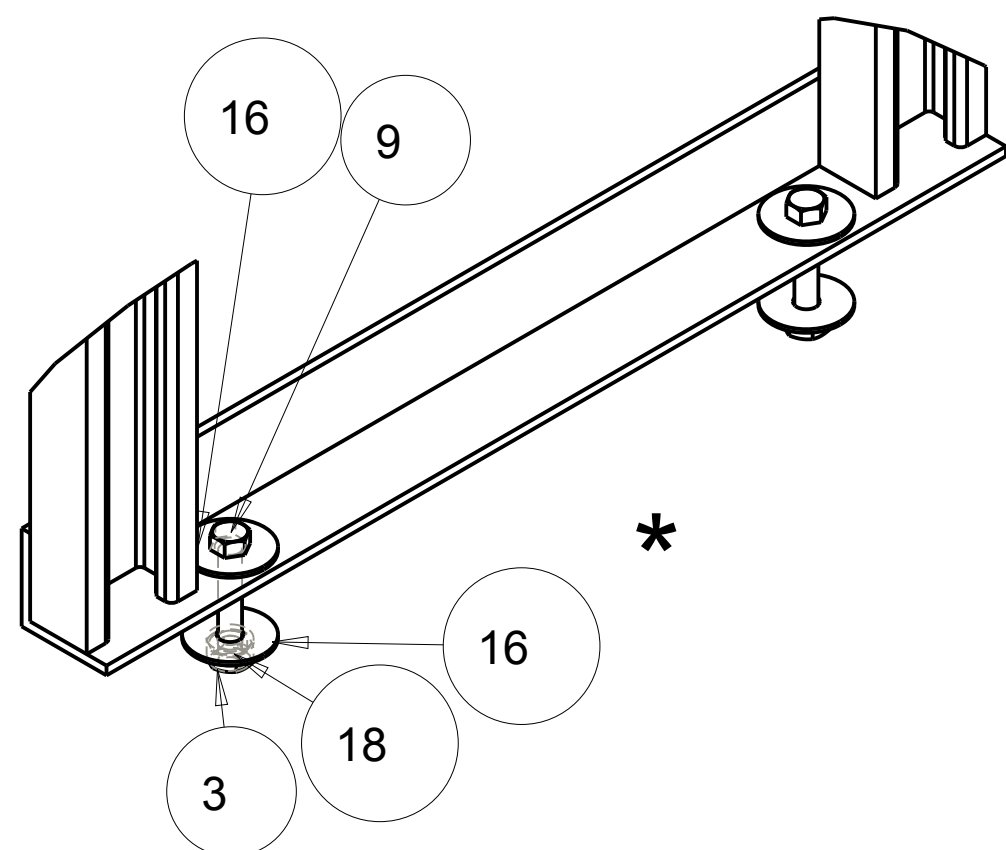

DETAIL D  
SCALE 0.500  
BOLT THRU FLOOR

CNUMBER	WEIGHT	TOLERANCE UNLESS OTHERWISE SPECIFIED	 A company of VT Systems
PROMASTER	134.808		
ROUTING	MATL CODE	.XX=+/- .060	252-946-6521 vtackney.com hackney.com kidron.com vtvisioncomms.com
FINAL	ZA	.XXX=+/- .030	
ITEM NO	SHAPE DESC		VisionComms
385496			
RAW_MATL	HRS	DESCRIPTION	
	0.000	SHELF ASM.- CURBSIDE PROMASTER 159"WB HIGH	
DRAWN BY	DATE	ROOF 23-46	
LCS	1 JUN 16		
APPROVED BY	DATE		
SUPERSEDES	SUPERSEDED BY	SCALE	DWG NAME
		0.125	P16C0293 Sheet 4 of 4