

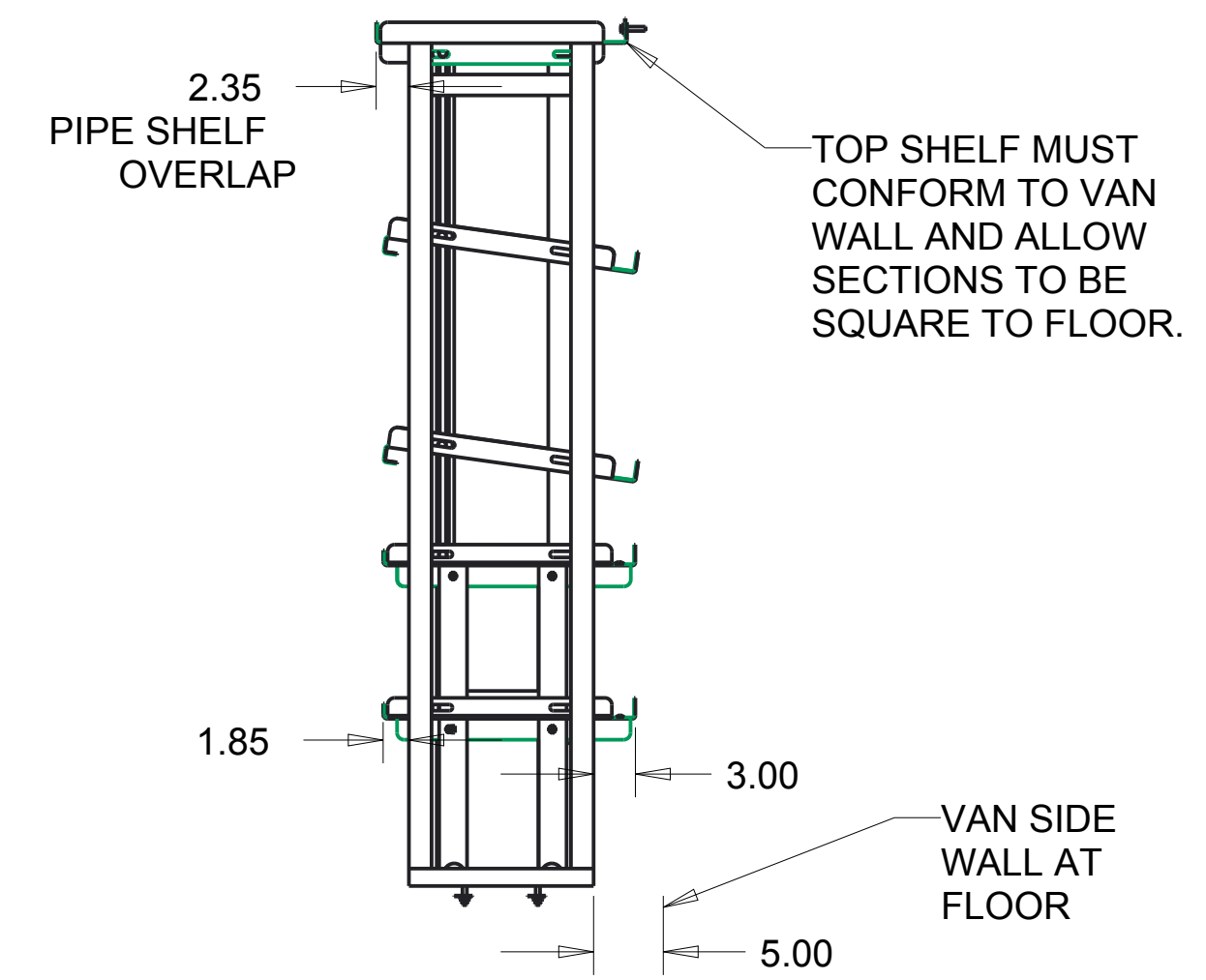

BBL NO.	ITEM DESCRIPTION	LENGTH	WIDTH	WEIGHT	MATL CODE	QTY REQD	ITEM NO.	MODEL NAME
1	ANGLE-.10X1.50X1.50X 13.25	13.250	2.810	0.334	BB2	2	385287	P15C0410
2	ANGLE-.10X1.50X1.50X 16.75 SPECIAL	16.750	3.310	0.531	BB2	4	386570	386570
3	ANGLE-1.25X 1.25X.12X 10.00	10.000		0.823	B0M	2	386576	386576
4	BAR-FLAT 2.00X.19X22.875" REINFORCEMENT			2.426	B1A	4	386572	386572
5	NUT-HEX .25 P			0.007	E1	22	1378	1378
6	NUT-HEX 0.38 LK			0.018	E1	4	1485	1485
7	NUT-HEX M8 x 1.25 SST			0.011	E1	4	820637	820637
8	NUT-UNISTRUT W/O SPRING .38-16			0.086	C4	40	802807	802807
9	SCREW-CARRIAGE .25X .50			0.014	E0	14	826255	826255
10	SCREW-CARRIAGE .25X .75			0.018	E0	8	1430	1430
11	SCREW-HEX M8-1.25x40MM SST			0.048	E0	9	820664	820664
12	SCREW-HEX.38X .75 GR5	0.750		0.043	E0	44	802804	802804
13	SHELF-TOP 18" X 54.875" RH CURBSIDE	54.875	18.000	11.327	BB2	1	386580	P17C0115
14	SHELF-TOP 18"x54.875" LH CURBSIDE	54.875	18.000	11.323	BB2	1	386579	P17C0114
15	SHELF-TRAY 18"x54" VENDING SHELF	54.000	18.000	10.951	BB2	4	386569	P17C0090
16	SHELF-TRAY 18"x54" VENDING TOTE SHELF	54.000	18.000	11.463	BB2	4	386568	P17C0089
17	UNISTRUT ASM-DOUBLE WB SPECIAL			9.054	ZA	1	386577	386577
18	UNISTRUT ASM-SINGLE			6.188	ZA	2	385289	385289
19	WASHER-FLAT .38 D-SHAPED			0.007	E2	57	816154	816154
20	WASHER-FLAT M8 SST			0.007	E2	8	820670	820670
21	WASHER-LOCK .25			0.002	E2	22	1372	1372
22	WASHER-LOCK M8 SST			0.004	E2	9	820638	820638

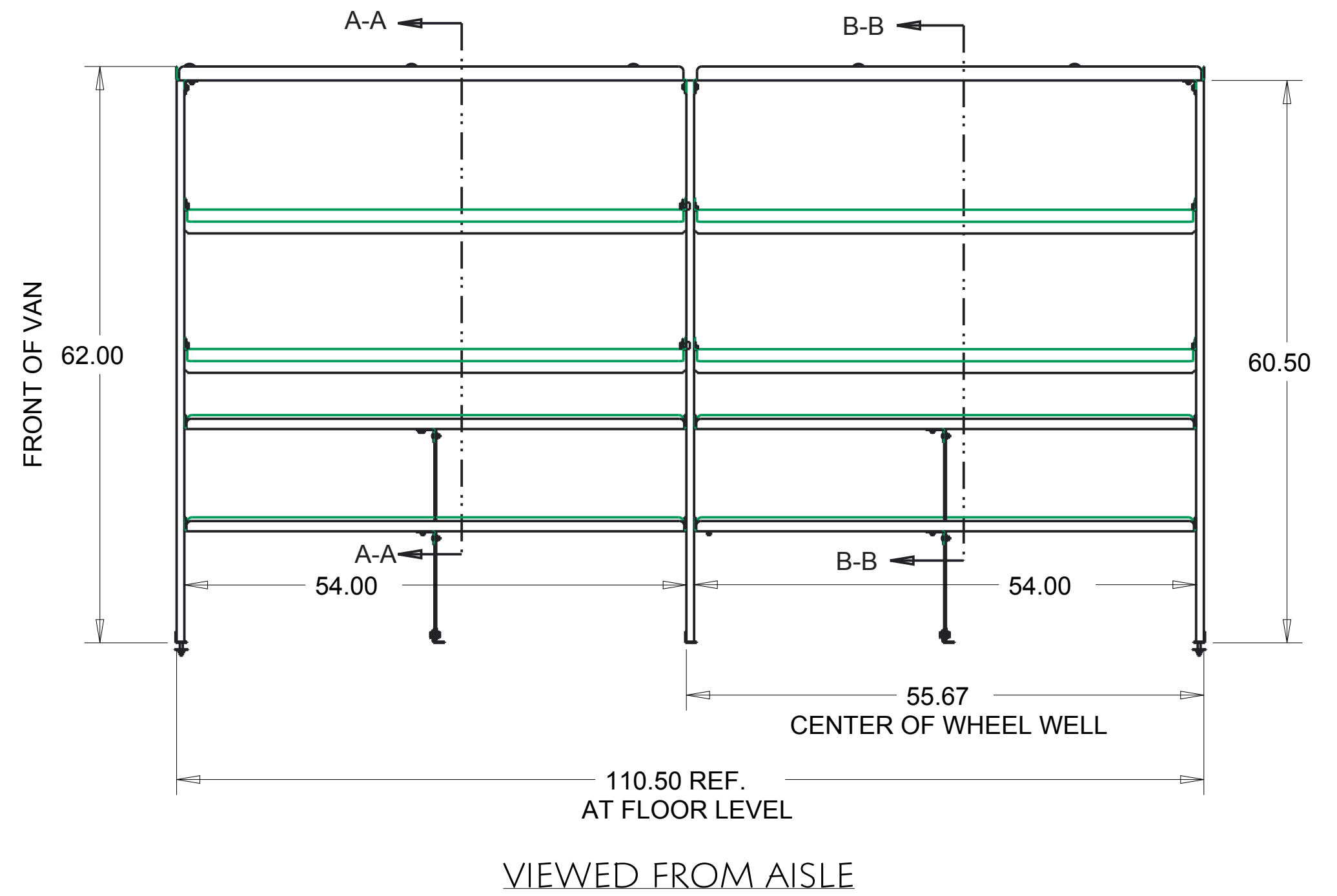

NUMBER	TRANSIT	WEIGHT	156.031	TOLERANCE UNLESS OTHERWISE SPECIFIED	
ROUTING	FINAL	MATL CODE	ZA	.XX=+/- .060	
ITEM NO.	386566	SHAPE DESC		.XXX=+/- .030	
RAW_MATL		HRS	0.000	DESCRIPTION	vthackney.com hackney.com kidron.com vtvisioncomms.com
DRAWN BY	LRE	DATE	Feb-24-17	SHELF ASM.- VENDING CURBSIDE FORD TRANSIT	
APPROVED BY		DATE		SCALE	0.075
SUPERSEDES		SUPERSEDED BY		DWG NAME	P17C0068 Sheet 1 of 4



VT Hackney  
A company of VT Systems



Kidron





VisionComms

252-946-6521

THIS PRINT AND ALL RIGHTS TO THE DESIGN AND DETAIL THEREON ARE THE PROPERTY OF VT HACKNEY AND IS LOANED TO THE RECIPIENT SUBJECT TO RETURN UPON DEMAND. ITS CONTENTS ARE CONFIDENTIAL AND MUST NOT BE COPIED OR SUBMITTED TO OUTSIDE PARTIES FOR USE OR EXAMINATION. COPYRIGHT 2017 VT HACKNEY A COMPANY OF VT SYSTEMS

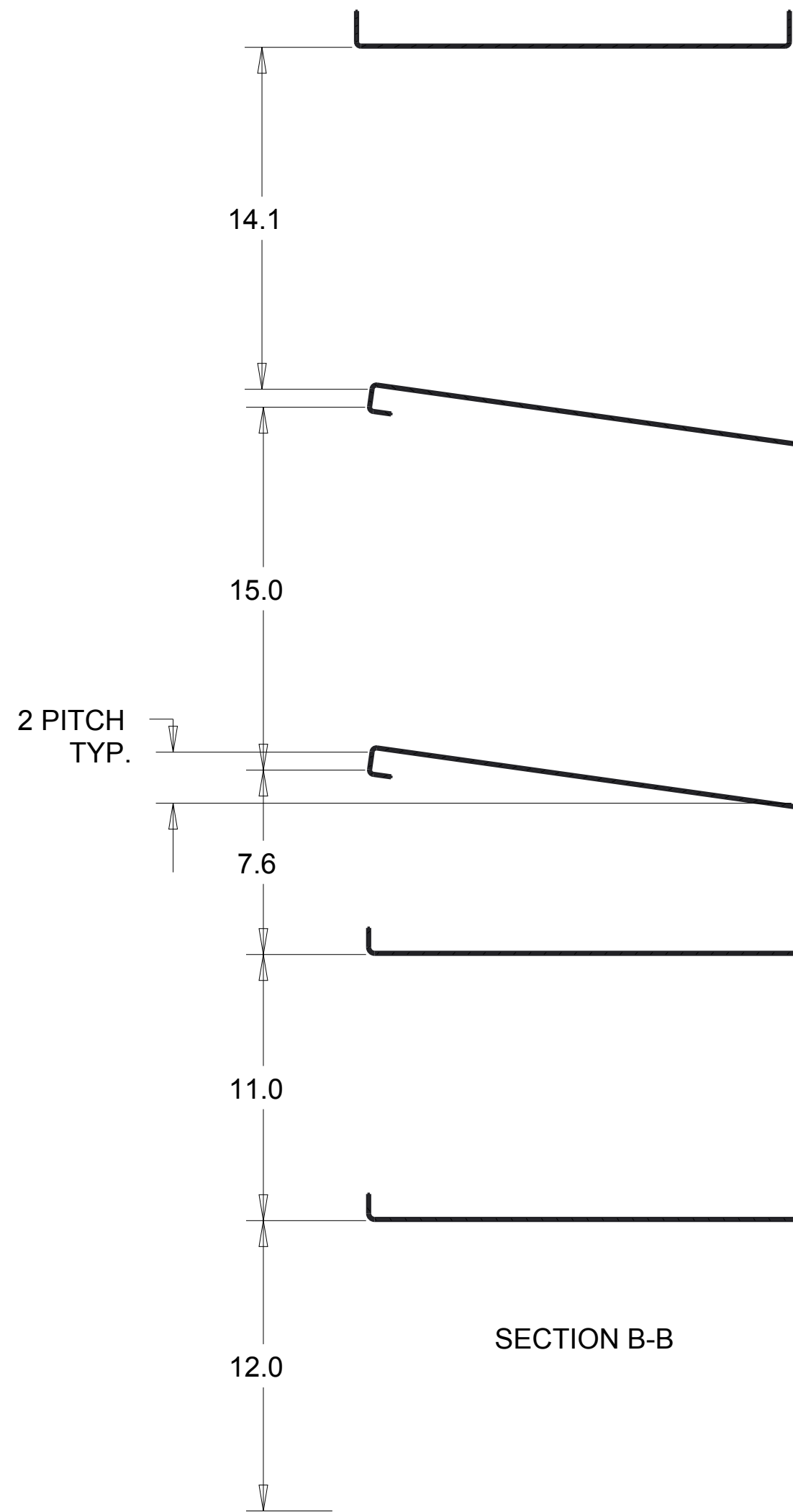
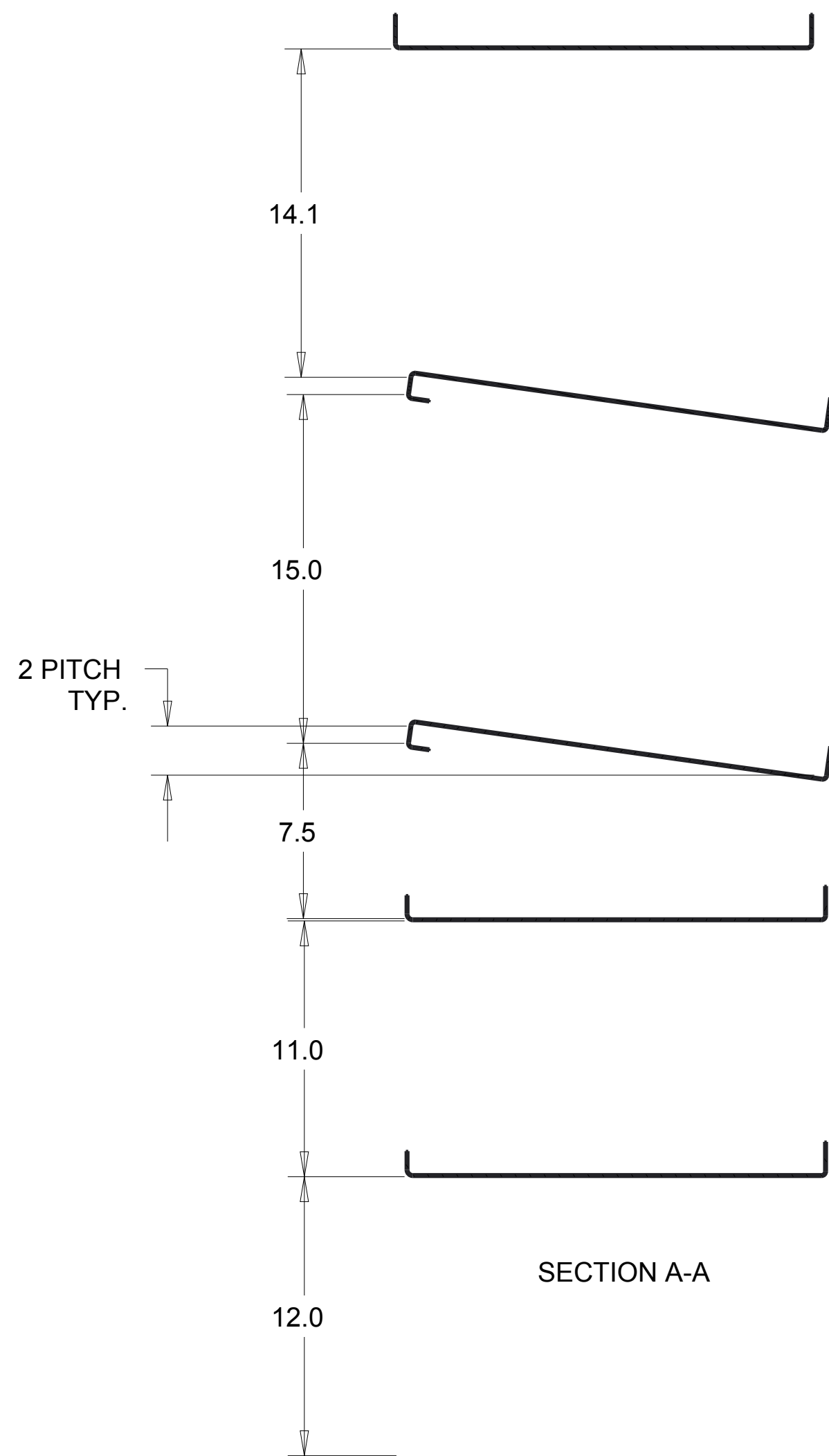
REV	REVISION DESCRIPTION	ECN	DATE	INITIALS



NUMBER TRANSIT	WEIGHT 156.031	TOLERANCE UNLESS OTHERWISE SPECIFIED	 <b>VT Hackney</b> A company of VT Systems	 <b>Kidron</b>
ROUTING FINAL	MATL CODE ZA	.XX=+/- .060 .XXX=+/- .030		
ITEM NO 386566	SHAPE DESC		252-946-6521 vtackney.com hackney.com kidron.com vtvisioncomms.com	
RAW_MATL	HRS 0.000	DESCRIPTION		
DRAWN BY LRE	DATE Feb-28-17	SHELF ASM.- VENDING CURBSIDE FORD TRANSIT		
APPROVED BY	DATE	SCALE 0.175	DWG NAME P17C0068 Sheet 2 of 4	
SUPERSEDES	SUPERSEDED BY			

**Hackney**

**Kidron**

**VisionComms**

SEE DETAIL A

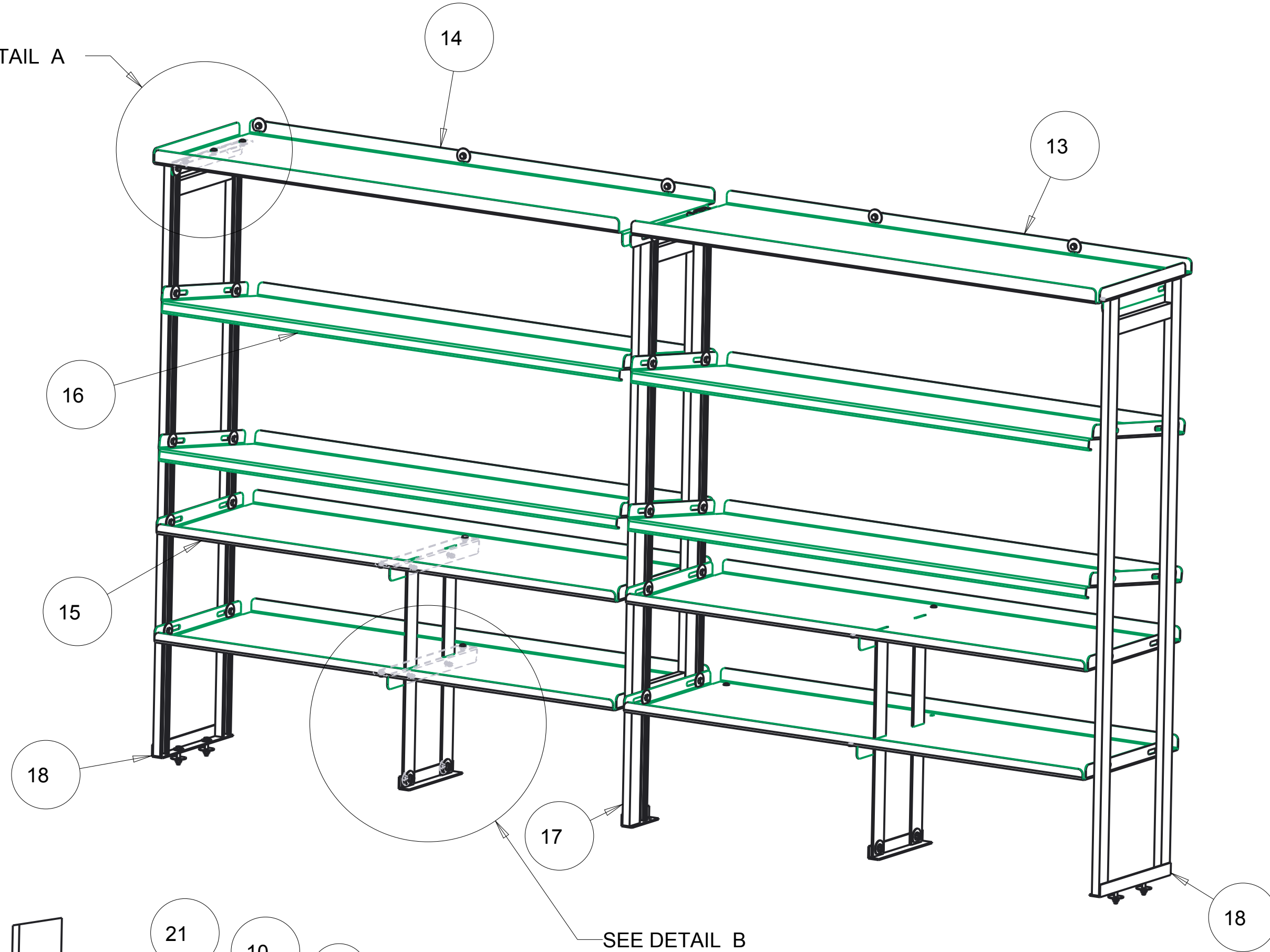

SEE DETAIL B

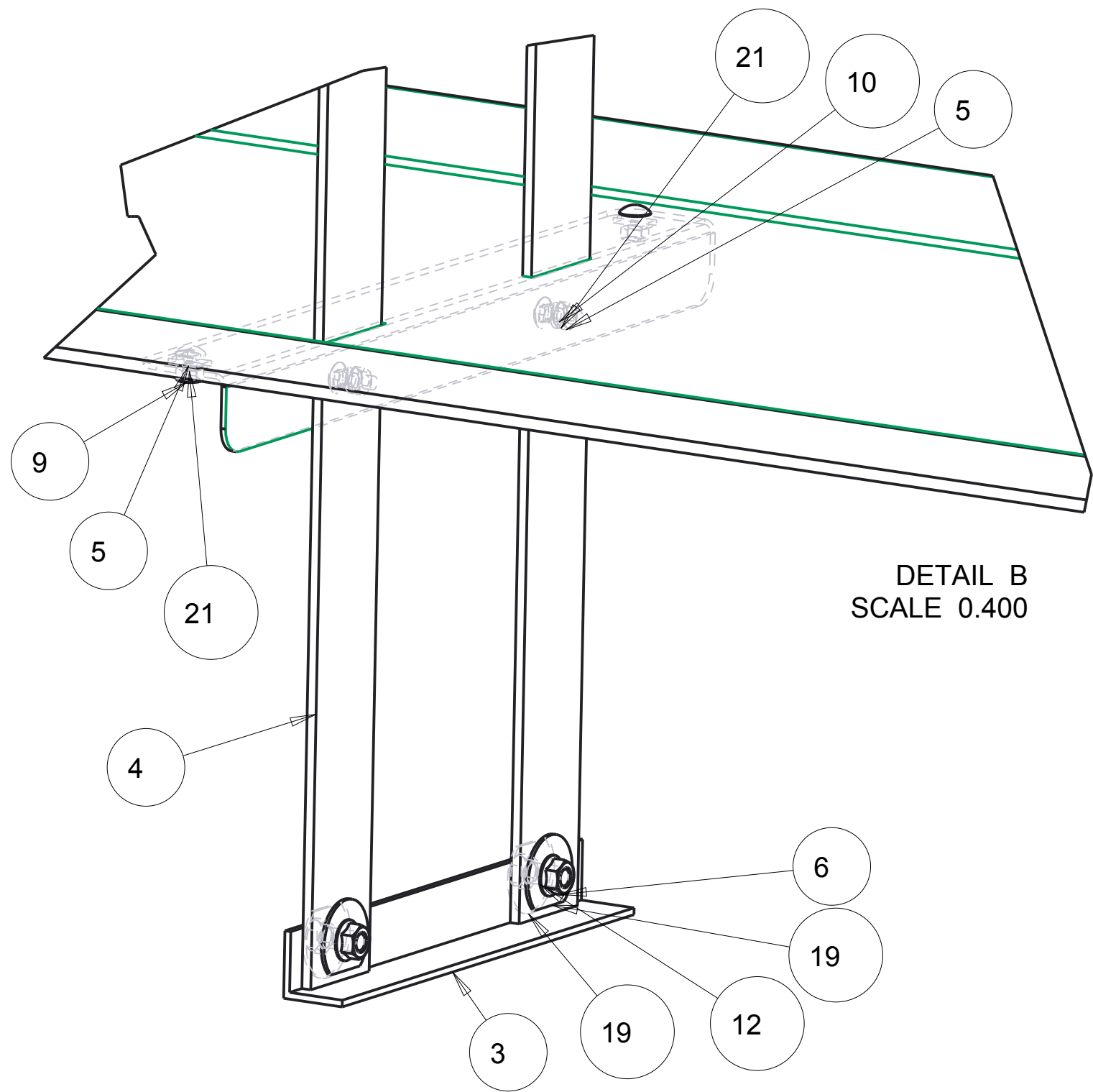

DETAIL B  
SCALE 0.400

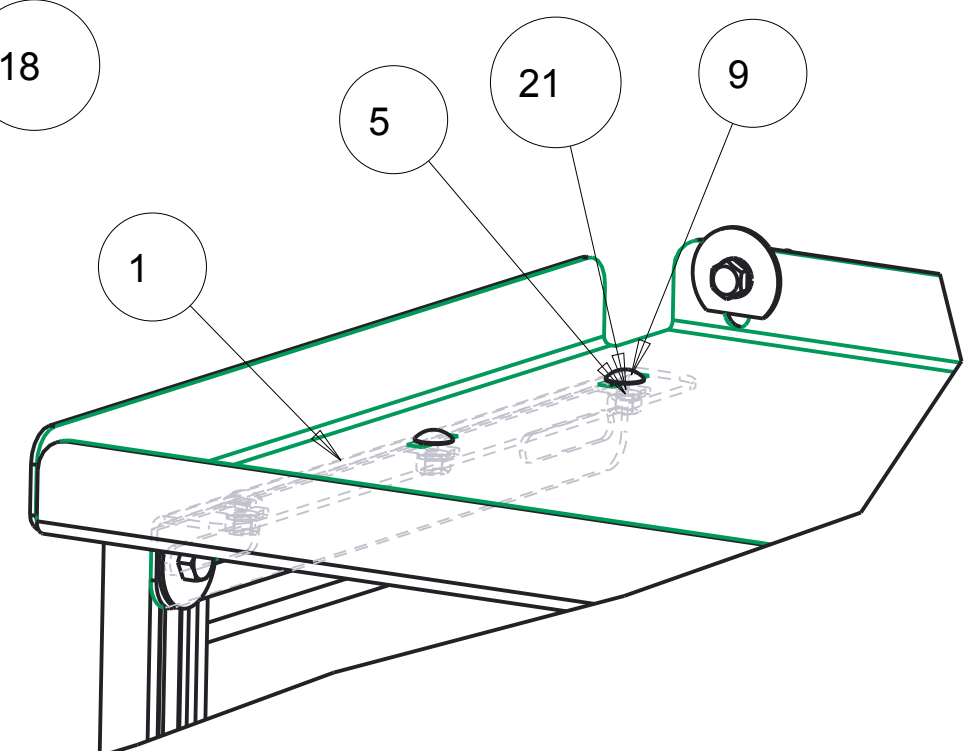

DETAIL A  
SCALE 0.350

CNUMBER <b>TRANSIT</b>	WEIGHT <b>156.031</b>	TOLERANCE UNLESS OTHERWISE SPECIFIED
ROUTING <b>FINAL</b>	MATL CODE <b>ZA</b>	.XX=+/- .060 .XXX=+/- .030
ITEM NO <b>386566</b>	SHAPE DESC	
RAW_MATL	HRS <b>0.000</b>	
DRAWN BY <b>LRE</b>	DATE <b>Feb-28-17</b>	DESCRIPTION
APPROVED BY	DATE	<b>SHELF ASM.- VENDING CURBSIDE FORD TRANSIT</b>
SUPERSEDES	SUPERSEDED BY	SCALE <b>0.100</b>
		DWG NAME <b>P17C0068 Sheet 3 of 4</b>



**VT Hackney**  
A company of VT Systems

*Hackney*

**Kidron**

**VisionComms**

252-946-6521  
vthackney.com hackney.com kidron.com vtvisioncomms.com



# ATTACHMENT DETAILS

SEE DETAIL C

LOCATE IN EXISTING HOLE IN VAN WALL.

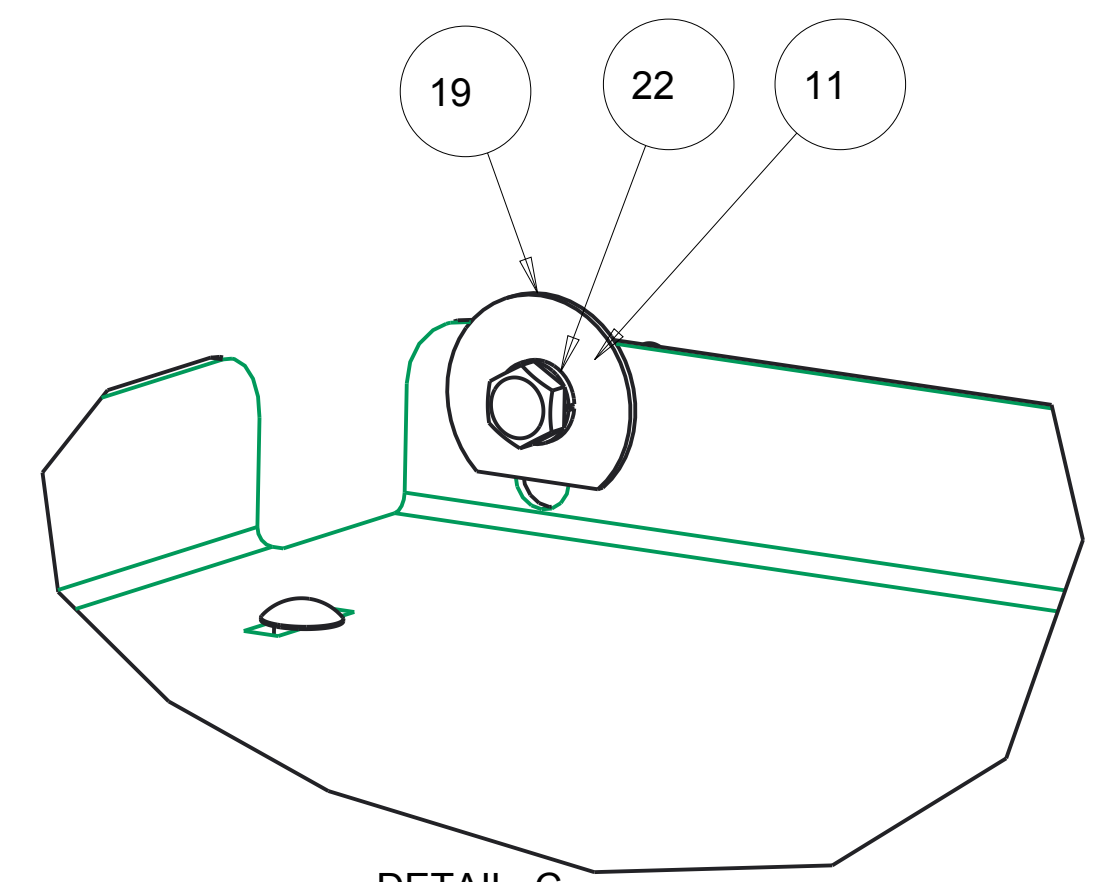
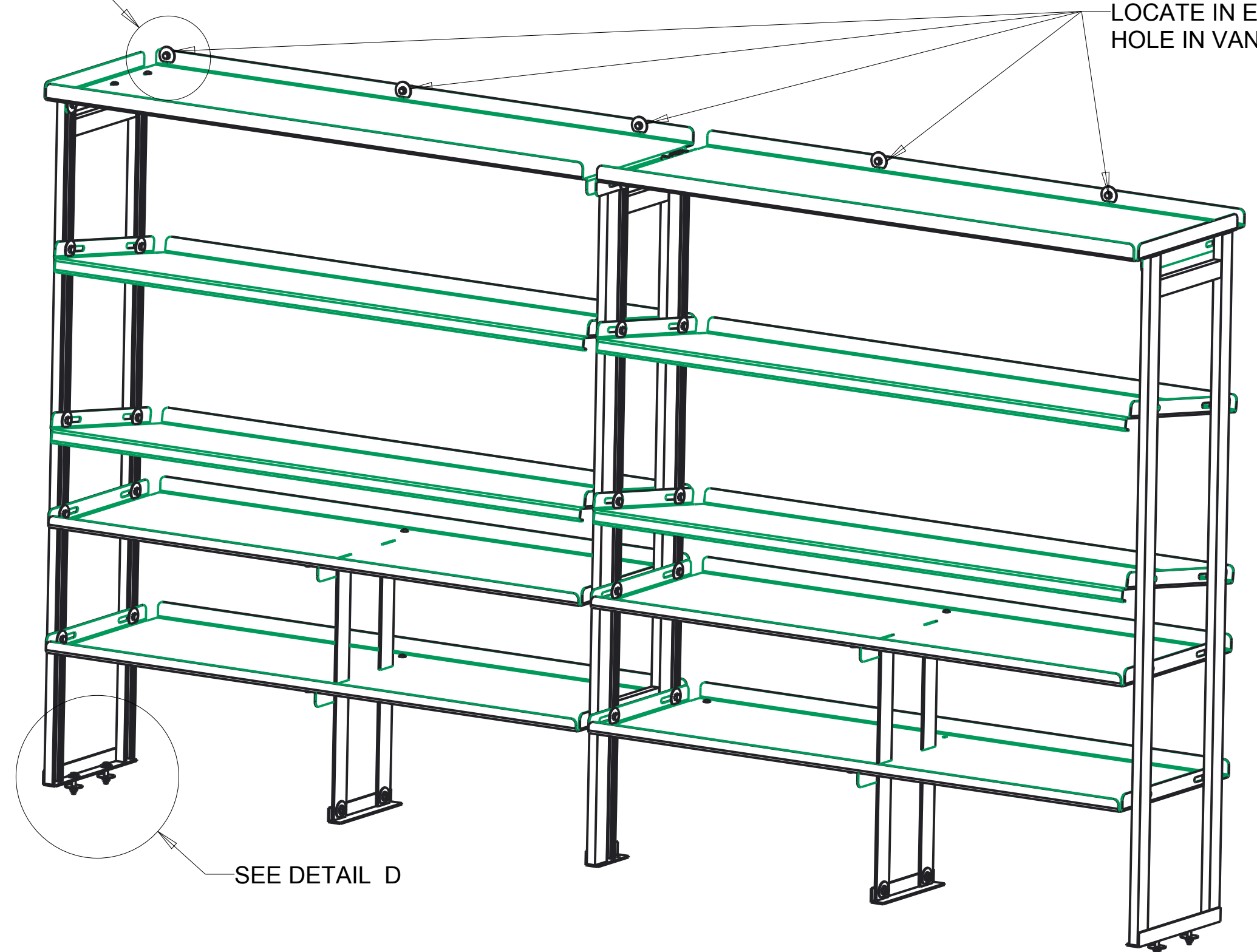

DETAIL C  
SCALE 0.750

SEE DETAIL D

**NOTE:**  
BEFORE DRILLING ANY HOLE THRU  
THE FLOOR OR WALL, VERIFY CLEARANCE  
ON BACKSIDE OF HOLE.

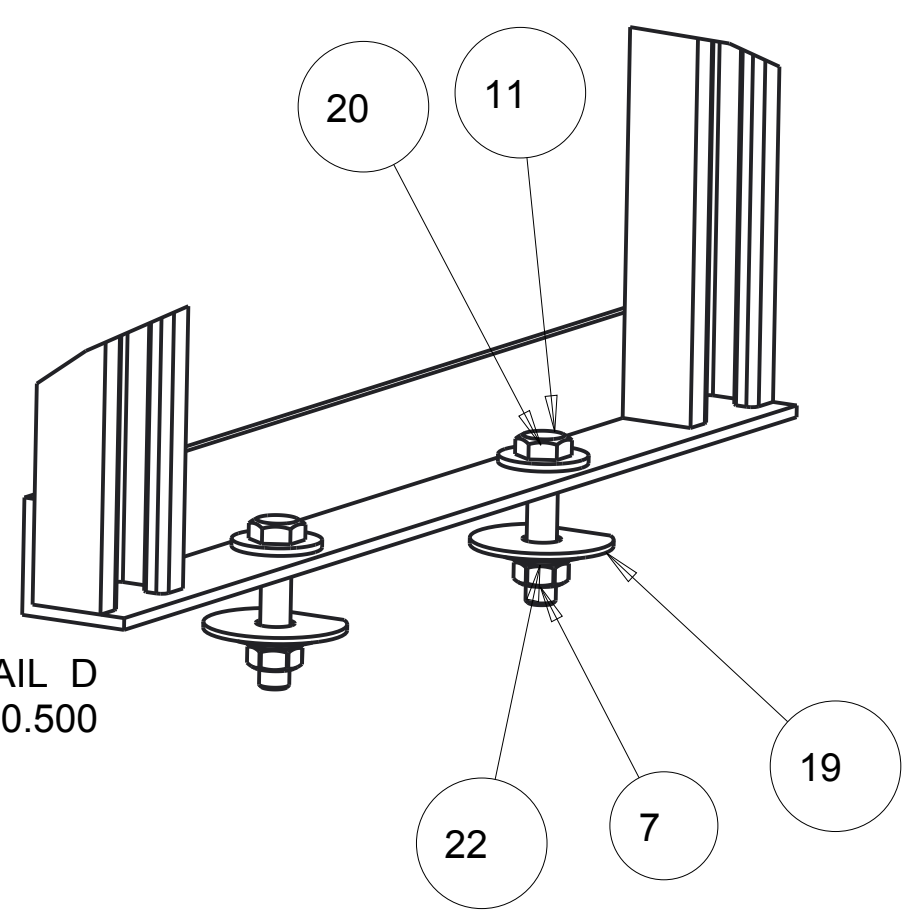

DETAIL D  
SCALE 0.500

NUMBER	WEIGHT	TOLERANCE UNLESS OTHERWISE SPECIFIED	 A company of VT Systems
TRANSIT	156.031		
ROUTING	MATL CODE	.XX=+/- .060	252-946-6521 vtackney.com hackney.com kidron.com vtvisioncomms.com
FINAL	ZA	.XXX=+/- .030	
ITEM NO	SHAPE DESC		<b>VISIONCOMMS</b>
386566			
RAW_MATL	HRS	DESCRIPTION	
	0.000	SHELF ASM.- VENDING CURBSIDE FORD TRANSIT	
DRAWN BY	DATE		
LRE	Feb-28-17		
APPROVED BY	DATE		
SUPERSEDES	SUPERSEDED BY	SCALE	DWG NAME
		0.100	P17C0068 Sheet 4 of 4