

ITEM NUMBER 385313

BBL NO.	ITEM DESCRIPTION	LENGTH	WIDTH	WEIGHT	MATL CODE	QTY REQD	ITEM NO.	MODEL NAME
1	ANGLE-.10X1.50X1.50X 13.25	13.250	2.810	0.334	BB2	3	385287	P15C0410
2	BAR-FLAT 1.00X.12X 7.00	7.000		0.239	B12	2	385241	385241
3	NUT-HEX .25 P			0.007	E1	17	1378	1378
4	NUT-HEX M8 x 1.25 SST			0.011	E1	4	820637	820637
5	NUT-UNISTRUT W/O SPRING .38-16			0.086	C4	58	802807	802807
6	PIPE STOP SHEET	16.000	8.810	1.311	BB2	2	385304	P15C0435
7	SCREW-CARRIAGE .25X .75			0.018	E0	17	1430	1430
8	SCREW-HEX M8-1.25x40MM SST			0.048	E0	9	820664	820664
9	SCREW-HEX.38X .75 GR5	0.750		0.043	E0	58	802804	802804
10	SHELF-TOP 18"x46.88"	46.875	18.000	10.732	BB2	1	385302	P15C0427
11	SHELF-TOP 18"x76.38"	76.375	18.000	17.126	BB2	1	385303	P15C0428
12	SHELF-TRAY 18"x24"	24.000	18.000	5.183	BB2	6	385296	P15C0418
13	SHELF-TRAY 18"x46"	46.000	18.000	9.633	BB2	6	385297	P15C0419
14	UNISTRUT ASM-DOUBLE			9.386	ZA	2	385288	385288
15	UNISTRUT ASM-SINGLE			6.188	ZA	2	385289	385289
16	WASHER-FLAT .38 D-SHAPED			0.007	E2	63	816154	816154
17	WASHER-FLAT M8 SST			0.007	E2	8	820670	820670
18	WASHER-LOCK .25			0.002	E2	17	1372	1372
19	WASHER-LOCK M8 SST			0.004	E2	9	820638	820638

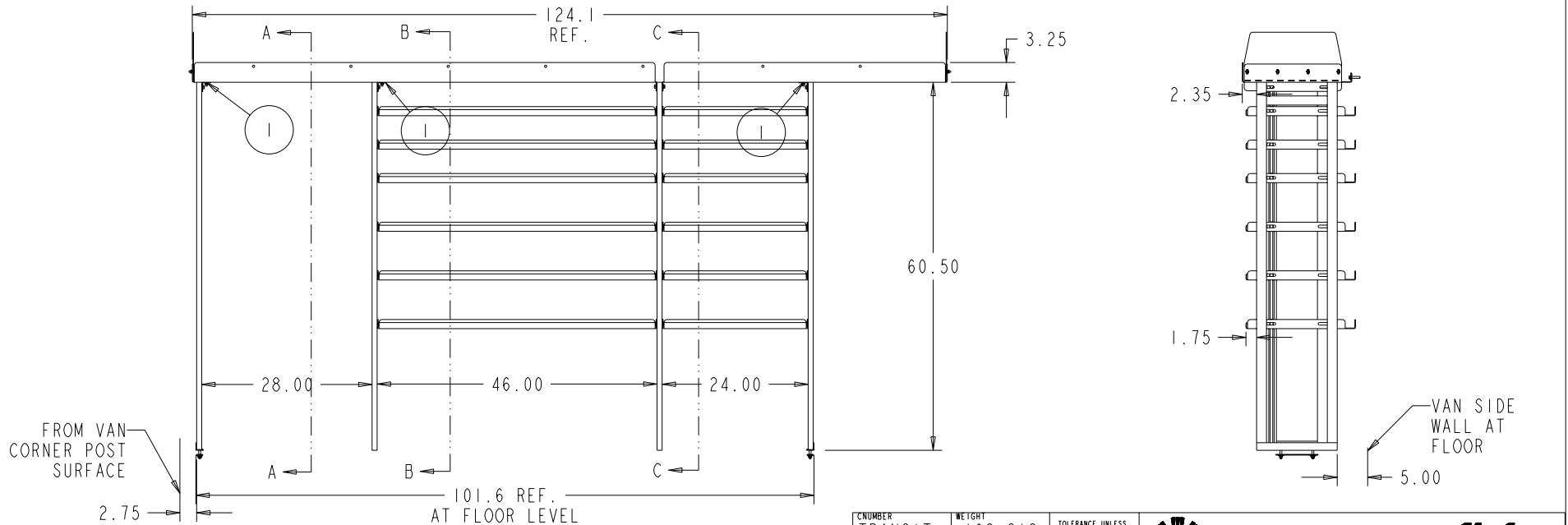

VIEWED FROM AISLE

CNUMBER	TRANSIT	WEIGHT	162.318	TOLERANCE UNLESS OTHERWISE SPECIFIED	
ROUTING	FINAL	MATL CODE	ZA	.XX=+/- .060	
ITEM NO	385313	SHAPE DESC		.XXX=+/- .030	
RAW MATL		HRS	0.000	DESCRIPTION	vthackney.com hackney.com kidron.com vtvisioncomms.com VisionComms
DRAWN BY	LCS	DATE	11 APR 13		
APPROVED BY		DATE			
SUPERSEDES		SUPERSEDED BY		SCALE	0.085
				DWG NAME	

**VT Hackney** *Hackney*  
A company of VT Systems **Kidron**

252-946-6521  
**SHELF ASM.- DRIVERSIDE FORD TRANSIT SHELF OPTION "TD2"**

THIS PRINT AND ALL RIGHTS TO THE DESIGN AND DETAIL THEREON ARE THE PROPERTY OF VT HACKNEY AND IS LOANED TO THE RECIPIENT SUBJECT TO RETURN UPON DEMAND. ITS CONTENTS ARE CONFIDENTIAL AND MUST NOT BE COPIED OR SUBMITTED TO OUTSIDE PARTIES FOR USE OR EXAMINATION. COPYRIGHT 2015 VT HACKNEY A COMPANY OF VT SYSTEMS

REV	REVISION DESCRIPTION	ECN	DATE	INITIALS

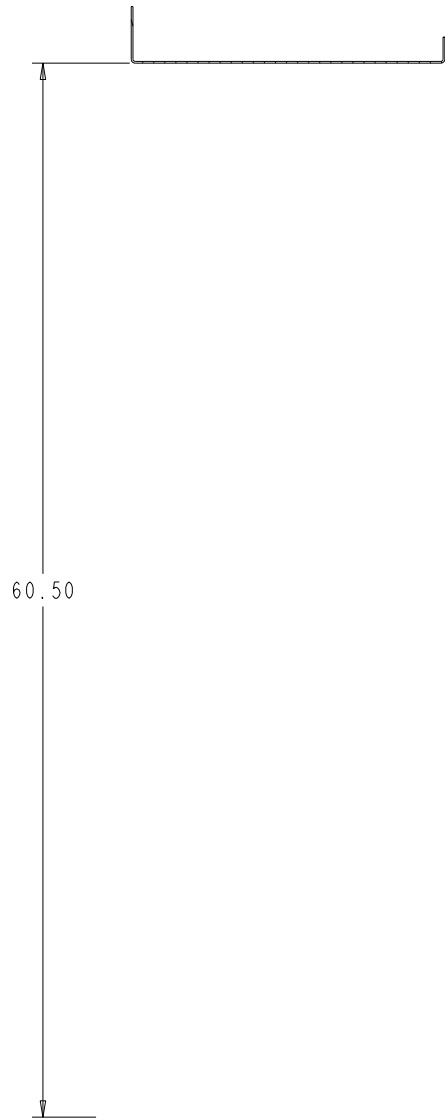

SECTION A-A

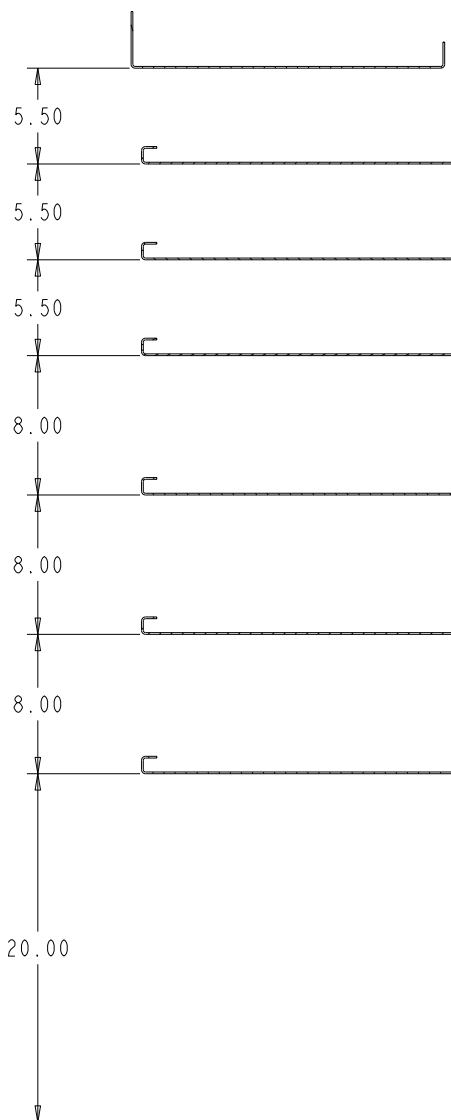

SECTION B-B

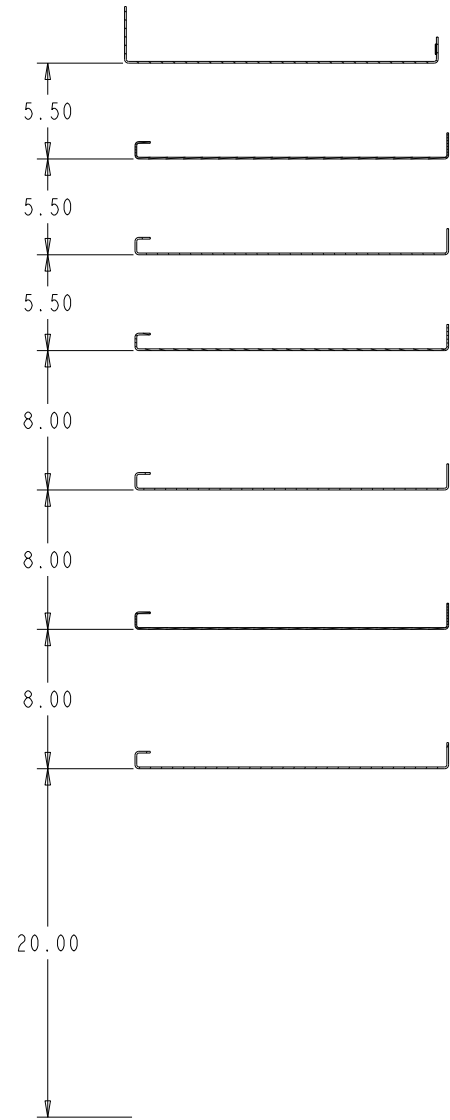

SECTION C-C

CNUMBER TRANSIT	WEIGHT 162.318	TOLERANCE UNLESS OTHERWISE SPECIFIED		
ROUTING FINAL	MATL CODE ZA	.XX=+/- .060 XXX=+/- .030		
ITEM NO 385313	SHAPE DESC			
RAW_MATL	HRS 0.000	DESCRIPTION vthackney.com hackney.com kidron.com vtvisioncomms.com		
DRAWN BY LCS	DATE 29-Nov-11	<b>SHELF ASM.- DRIVERSIDE FORD TRANSIT SHELF OPTION "TD2"</b>		
APPROVED BY	DATE	SCALE 0.200	DWG NAME <b>P15C0459 Sheet 2 of 4</b>	
SUPERSEDES	SUPERSEDED BY			

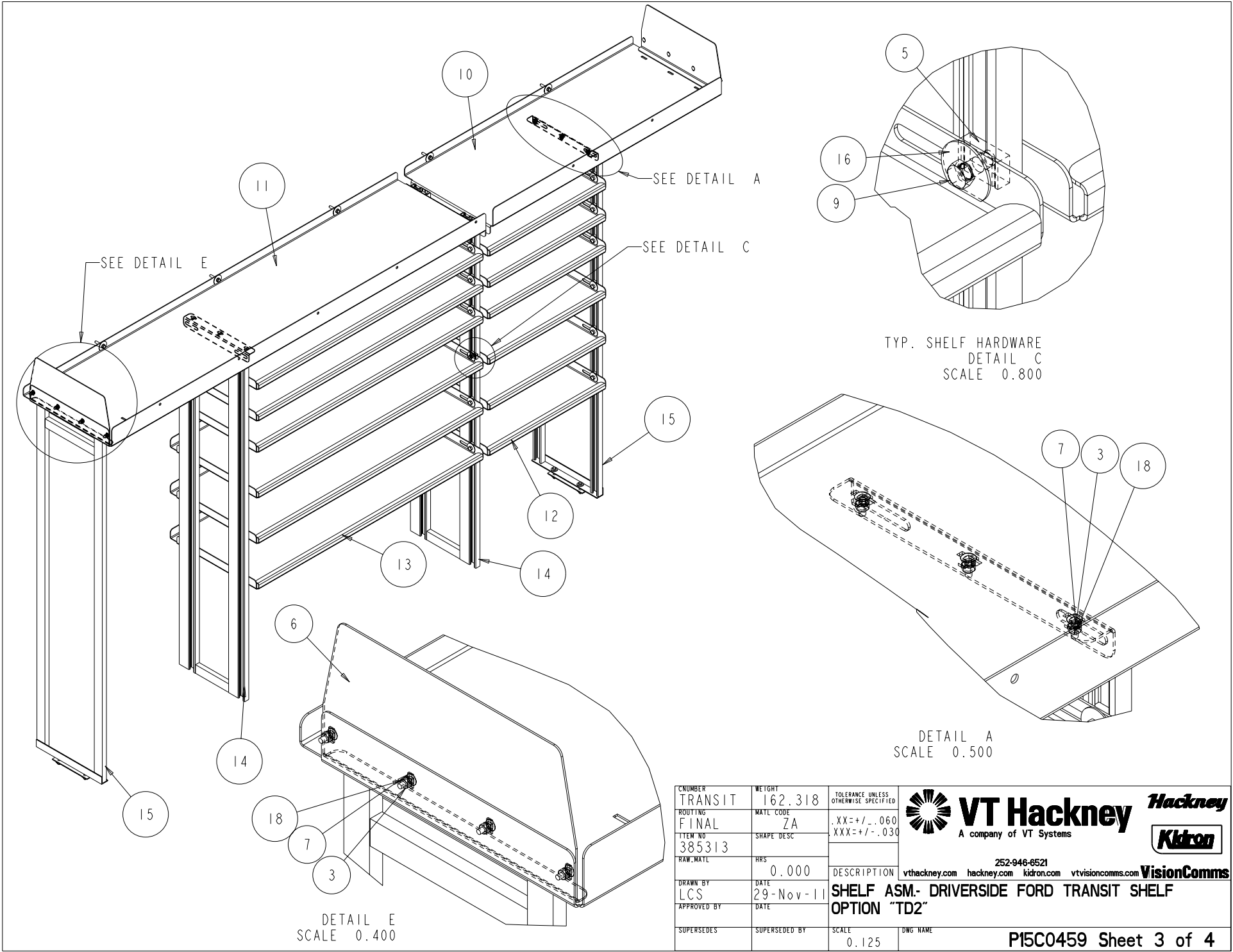

TYP. SHELF HARDWARE  
DETAIL C  
SCALE 0.800

DETAIL A  
SCALE 0.500

DETAIL E  
SCALE 0.400

CNUMBER	WEIGHT	TOLERANCE UNLESS OTHERWISE SPECIFIED
TRANSIT	162.318	
ROUTING	MATL CODE	
FINAL	ZA	.XX=+/- .060 XXX=+/- .030
ITEM NO	SHAPE DESC	
385313		
RAW_MATL	HRS	
	0.000	
DRAWN BY	DATE	DESCRIPTION
LCS	29-Nov-11	vtackney.com hackney.com kidron.com vtvisioncomms.com
APPROVED BY	DATE	<b>SHELF ASM.- DRIVERSIDE FORD TRANSIT SHELF OPTION "TD2"</b>
SUPERSEDES	SUPERSEDED BY	SCALE
		0.125
		DWG NAME

**VT Hackney** *Hackney*  
A company of VT Systems **Kidron**

252-946-6521  
vtackney.com hackney.com kidron.com vtvisioncomms.com **VisionComms**

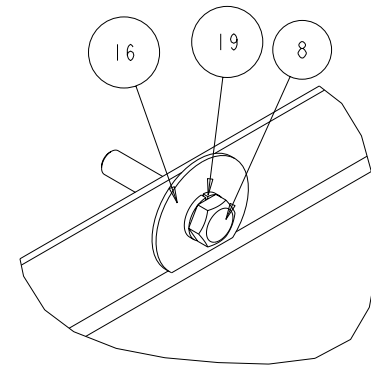
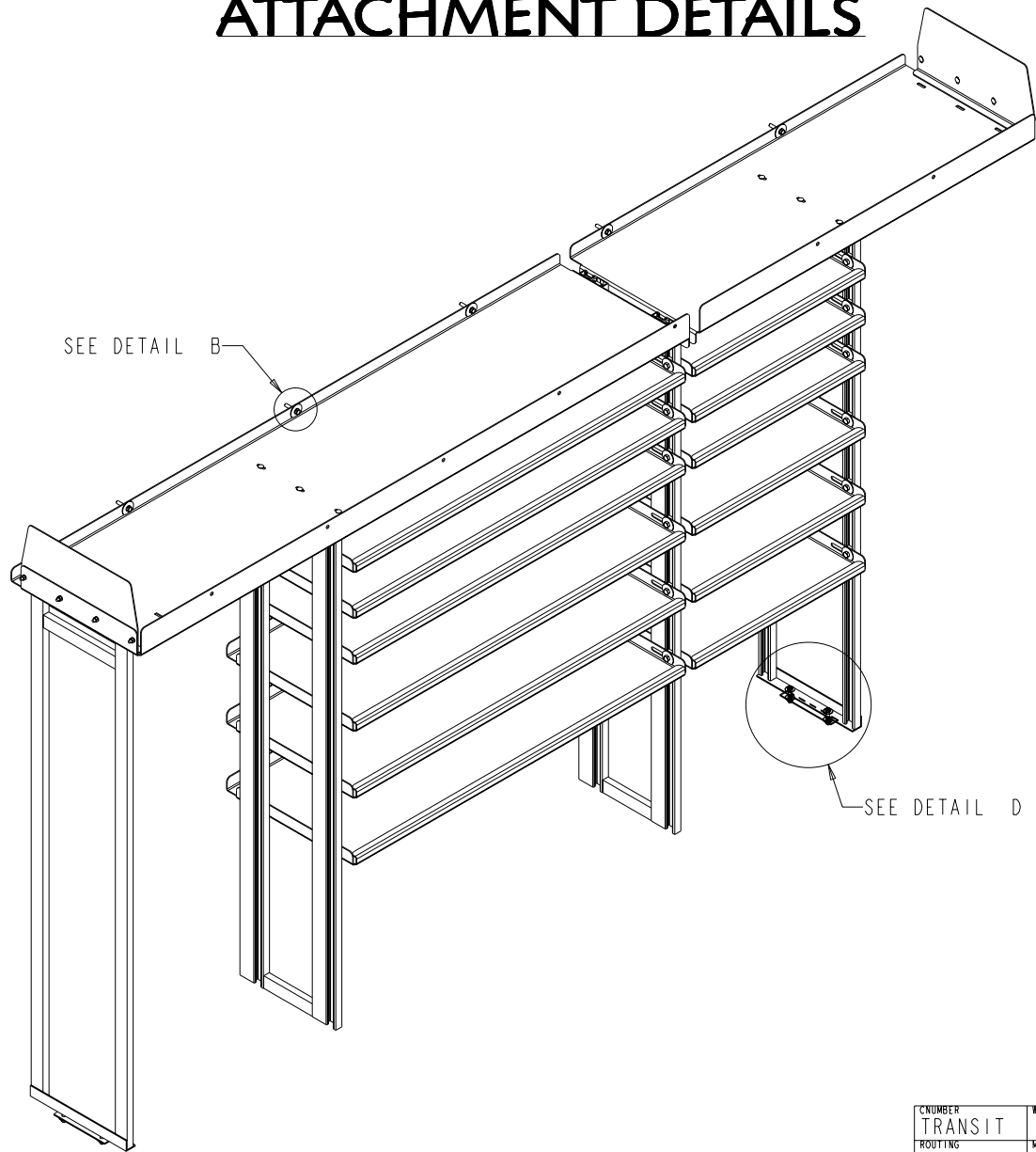

# ATTACHMENT DETAILS

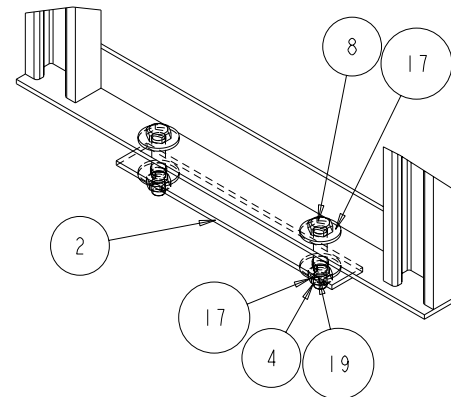

DETAIL B  
SCALE 1.000



DETAIL D  
SCALE 0.500  
TYPICAL BOLT  
THRU FLOOR

CNUMBER	WEIGHT	TOLERANCE UNLESS OTHERWISE SPECIFIED	 <b>VT Hackney</b> A company of VT Systems	
TRANSIT	162.318			
ROUTING	MATL CODE	.XX=+/- .060 XXX=+/- .030	252-946-6521 vtackney.com hackney.com kidron.com vtvisioncomms.com	<b>VisionComms</b>
FINAL	ZA			
ITEM NO	SHAPE DESC		DESCRIPTION	
385313			SHELF ASM.- DRIVERSIDE FORD TRANSIT SHELF OPTION "TD2"	
RAW MATL	HRS		SCALE	DWG NAME
	0.000		0.125	P15C0459 Sheet 4 of 4
DRAWN BY	DATE			
LCS	29-Nov-11			
APPROVED BY	DATE			
SUPERSEDES	SUPERSEDED BY			